

51. OUTLINE



This digital watch is equipped with a newly developed shock switch (shock sensor) and stopwatch which can be started and stopped easily. Therefore, this watch is suitable for bicycle, ski and marathon racing etc.

In addition, this watch is equipped with a start warning timer (D130/D131) and stop watch memo function, thus it is especially effective for individual training.

52. SPECIFICATIONS

Caliber No.		D130	D131	D132
Type		Digital watch with shock sensor		
Module size (mm)		28.4 x 26.3, thickness: 5.4 t		
Accuracy		±20 sec/month (at normal temperature)		
Oscillation		32,768 Hz		
Display method		FE twist-type nematic LC (Liquid Crystal)		
Integrated circuit		C/MOS-LSI (1 unit)		
Effective temp. range		0°C ~ +55°C (32°F ~ 131°F)	-20°C ~ 55°C (-4°F ~ 131°F)	0°C ~ 55°C (32°F ~ 131°F)
Adjustment of time rate		Trimmer condenser		
Measurement of time rate		2 seconds		
Display functions	Normal time/Calendar	(AM/PM) Hour, minute, second, 12/24 hour switching function Month, date, day, year (Year displayed only in correction mode)		
	Alarm 1	(AM/PM) Hour, minute (12/24 hour display interlocked with normal time and calendar)		
	Alarm 2	(AM/PM) Hour, minute, day		
	Timer	Minute, second (Up to 99 minutes, 99 seconds)		
	Stopwatch	12-hour system (with split time/lap time measuring function)		
Additional functions		Lamp	Without lamp	Lamp
		<ul style="list-style-type: none"> ● Graphic display ● Fully automatic calendar (1988 ~ 2003) ● Stopwatch memo (up to 9 data) ● Stopwatch counter (00 ~ 99) ● Sound monitor 		
Power cell	Part No.	280-204	280-206	280-204
	Battery cord No.	CR2016		
	Size (mm)	φ20.0 x 1.6 t		
	Nominal voltage	3 V		
	Nominal capacity	65 mA·H		
	Life time	Approx. 3 years		
Current consumption		2.4 μA max. (Under normal operating condition)		
Remarks		D130 series including CAL. D130 (Cycle sports), CAL. D131 (Ski sports) and CAL. D132 (Jogging sports) are the calibers of the same type equipped with shock sensors.		

Main differences among CAL. No. D130, D131 and D132

CAL. No.	D130	D131	D132
1. Appearance view	 <p>Cycle sports</p>	 <p>Ski sports</p>	 <p>Jogging sports</p>
2. Module			
a) Display part	<ul style="list-style-type: none"> Standard LC display panel (0 ~ 55°C/ 32 ~ 131°F) 	<ul style="list-style-type: none"> (*1) LC display panel for use at low temperature (-20° ~ 55°C/ -4 ~ 131°F) 	<ul style="list-style-type: none"> Standard LC display panel (0 ~ 55°C/ 32 ~ 131°F)
b) Power cell	<ul style="list-style-type: none"> Standard lithium battery 	<ul style="list-style-type: none"> (*2) Lithium battery for use at low temperature 	<ul style="list-style-type: none"> Standard lithium battery
Power cell type	2025	CR2025	280-204
Power cell code	C130	C131	CR2016
c) Lamp	<ul style="list-style-type: none"> Installed 	<ul style="list-style-type: none"> Not installed 	<ul style="list-style-type: none"> Installed
d) Stopwatch	<ul style="list-style-type: none"> With start warning timer (30-sec start timer) 	<ul style="list-style-type: none"> ← 	<ul style="list-style-type: none"> Without start warning timer (Starts at time when shock is give.)
Stopwatch memory	<ul style="list-style-type: none"> With stop time memory function 	<ul style="list-style-type: none"> ← 	<ul style="list-style-type: none"> With stop time memory and split time memory functions
3. Band	<ul style="list-style-type: none"> Standard band 	<ul style="list-style-type: none"> Extension band 	<ul style="list-style-type: none"> Standard band

(*1, *2)

CAL. No. D131 is developed to be used for ski sports and so designed that it can be used even at -20°C (-4°F). If a wrong power cell is used, this watch may not function normally. Be sure to use the genuine power cell.

CAL. D130 will be mainly explained below.

53. SHOCK SWITCH (SHOCK SENSOR)

If a shock is applied to the watch in the following modes by tapping, slapping or otherwise applying a shock to the watch with hand or against body.

1) Alarm mode

While the alarm is sounding, if a shock is given, the alarm stops.

2) Timer mode

If a shock is given, the timer starts.

3) Stopwatch mode

If a shock is given, a split/lap time can be measured.

(For the detail, see the section of the operation of the stopwatch.)

How to given a shock

The shock sensor is installed to the case back. Fit the watch correctly to wrist and hit the glass surface of the watch with a part of the body (hip born, knee, etc).

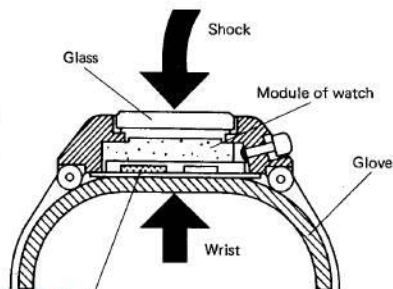

* Shock sensor does not accept shocks from lateral direction. Give shocks vertically.

Fitting method of watch

If the watch is fitted to the inside of the wrist, you can give shocks to it easily while you are training.

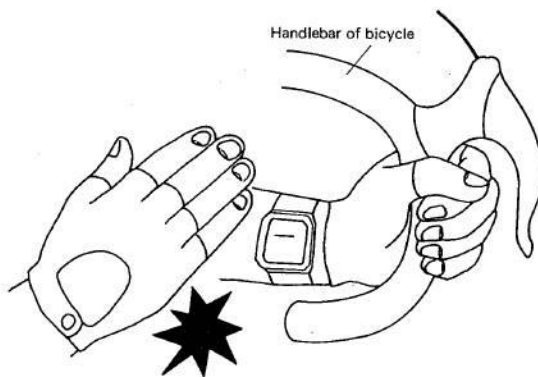

* If a shock is given, the confirmation sound is heard. When the sound does not come out, the shock switch is not turned on. In this case, hit the watch again.

54. HANDLING INSTRUCTIONS

4-1. Specifications of buttons



- (R) button: Correction button
- (S) button: Button for selecting digit to be corrected
- (ST) button: Start and Stop button
- (SL) button: Split button
- (M) button: Mode selection button
- (L) button: Lamp button
- (G) button: Shock

(D131: without lamp)

4-2. Changing the mode

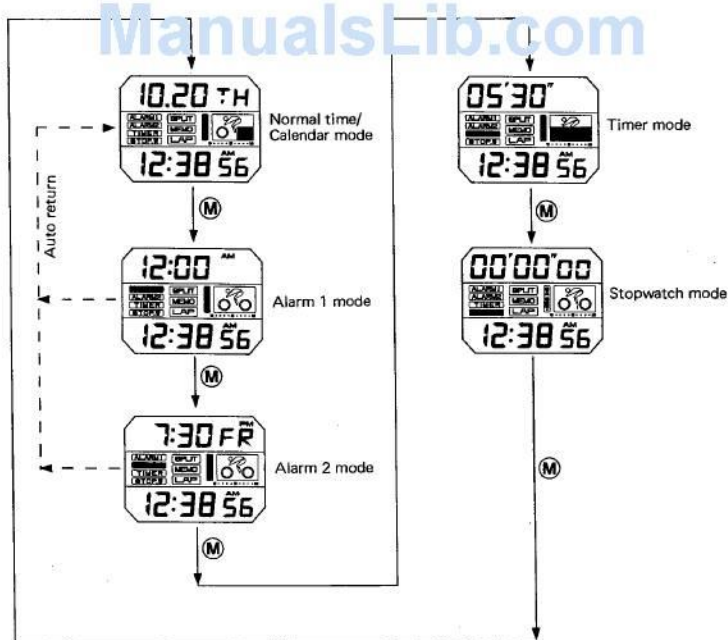

- The mode is changed every time the (M) button is pressed. (However, if the stopwatch is running or measuring split or lap time, it is required to press and hold the (M) button for more than 2 seconds.)
- If the watch is left untouched in alarm 1 or 2 mode for more than about two minutes, the watch is automatically returned to the normal time/calendar mode (Auto-return function).

Follow-up indicator for each mode

Mode mark indicator



Graphic indicator

Normal time indicator (Hour, minute, second)

Operation common to correction

Notes:

Selection the correcting mode

Select the mode to be corrected by pressing the (M) button, then press and hold the (S) button until the digits blink. Press the (S) button to select the digits to be corrected, and correct it with the (R) button.

Quick correction

While correcting an digits in each mode, if the (R) button is pressed and held, the digits is advanced quickly.

Auto-return

- (1) If alarm 1 or 2 mode is kept unchanged for more than about two minutes, the watch is automatically returned to the normal time/calendar mode.
- (2) If the correcting state in each mode is kept for more than about two minutes, the watch is automatically returned to the normal state in the current mode.

Manual return (Forced return)

If the (M) button is pressed while correcting a digit in each mode, the correcting state is finished forcedly and the watch is returned to the normal state in the current mode.

The mark ○ indicates a flashing position.

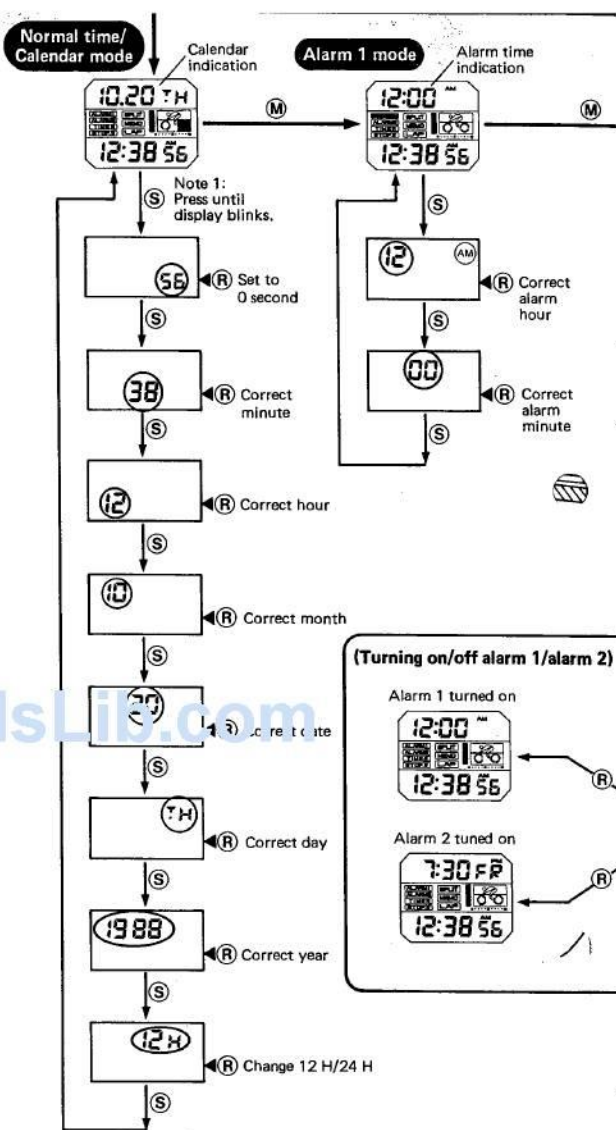

- Correction of second: If the second indication is corrected while the watch is indicating 39 seconds ~ 59 seconds, the minute indication is advanced by one minute.
- In a non-existing date is set and the watch is returned to the normal state, the 1st day of the next month is indicated. (Example: Feb. 31 → Mar. 1)
- The year can be set the 1988 ~ 2003. It is not necessary to correct the date at ends of months during this period.

- The basic setting methods of alarm 1 and alarm 2 are the same. However, an alarm day of week can be set in alarm 2 mode.
- 12-hour system and 24-hour system are in accordance with that in the normal time/calendar mode.
- If (R) button is pressed in while the alarm time is indicated, the alarm can be turned on and off.

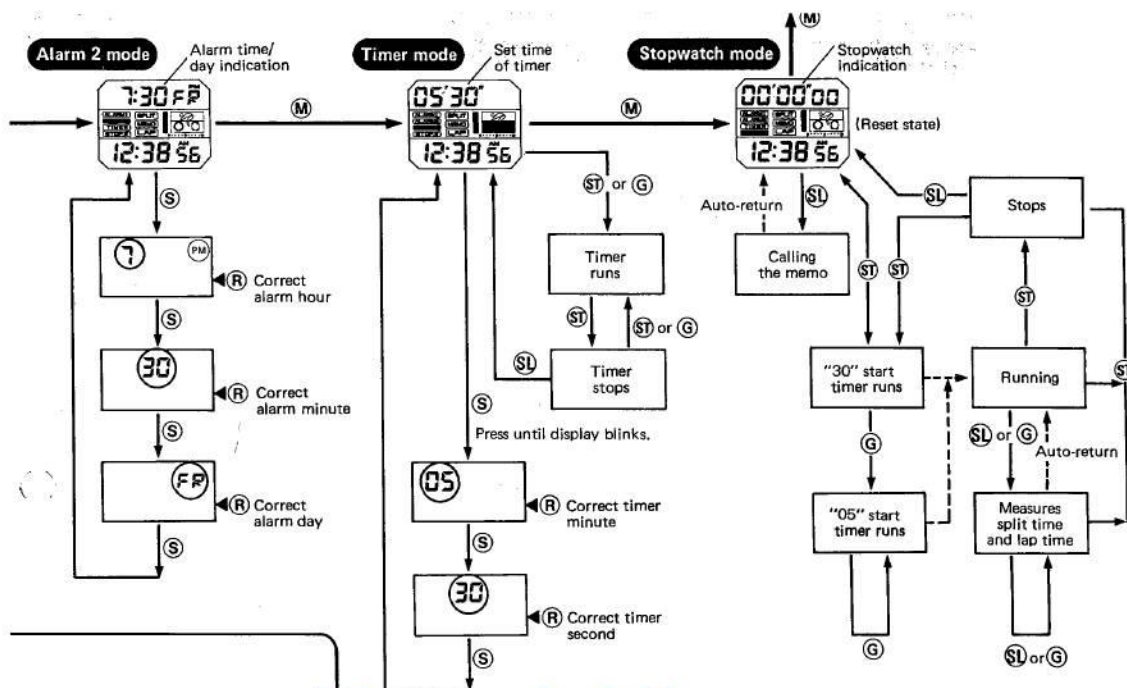

* For the detail, see the section of the stopwatch.

Alarm 1/Alarm 2 turned off



- In alarm 1/alarm 2 mode, it is turned on and off every time (R) button is pressed.

- If the alarm time is corrected, the alarm is turned on automatically.
- The alarm sounds for 20 seconds. It can be stopped by pressing any button. It can be also stopped by slapping the watch.

- The timer can be set up to 60 minutes and 59 seconds.
- Auto-repeat: When the timer is up, the confirmation sound comes out, then the timer starts counting down from the set time again.
- The confirmation sound comes out for two seconds.
- The timer can be started by giving a shock to it.
- After the timer is stopped by pressing (SL) button, the sound continues for about two seconds, then it stops.

- Start timer function: 30-second start timer. The start time can be jumped to 5 seconds start timer by shock.
- 12-hour system: Can measure time up to 11 hours, 59 minutes, 59 seconds.
- * The start timer cannot be cancelled. (D132 is not equipped with a start timer. It is set to the running mode the moment the start operation is performed.)

4-4. Operation of stopwatch (Example for CAL. No. D130 and D131)

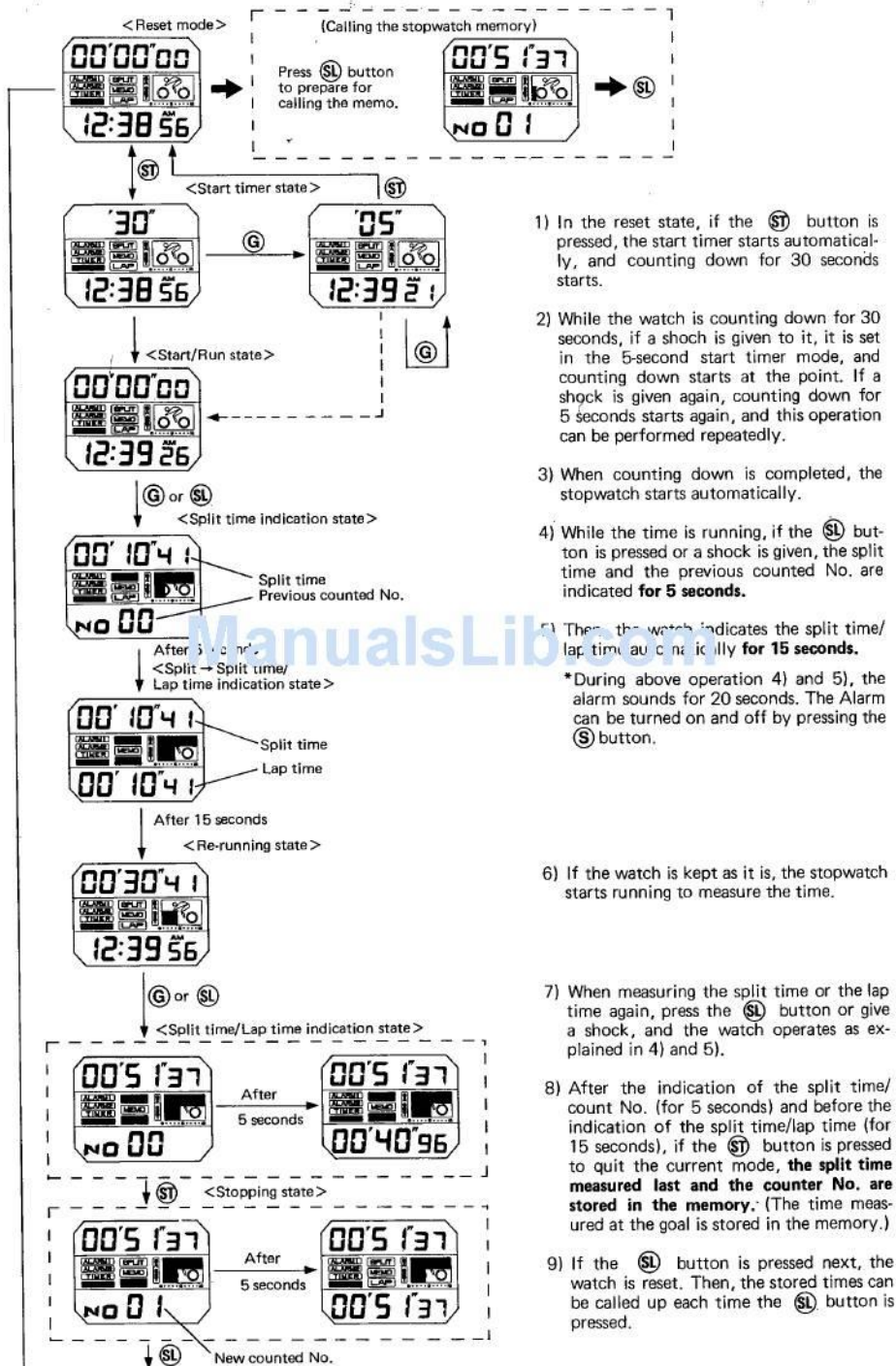

[Features of operation of stopwatch]

This watch has both stopwatch function and start timer function. With these functions, the start timer function is started by simply pressing the **ST** button before starting a race, and the stopwatch starts automatically when the start timer is up. At this time, the confirmation sound comes out. Thus, this watch is very convenient when it is used for an individual training of a sport where the user must hold tools in both hand.

(However, CAL. No. D132 does not have the start timer function. It can be started in the reset state by simply pressing the **ST** button or giving a shock.)

● Start timer (Start warning timer)

If the **ST** button is pressed one time in the stopwatch mode, the upper LC displays "30 seconds" and it is counted down automatically.

While the start timer is counting down, the confirmation sound comes out at 25, 20, 15, 10, 5, 4, 3, 2, 1 and 0 seconds.

While the start timer is counting down, it is set in the 5-second timer mode every time a shock is given to it.

This function is convenient when the preparation does not need time more than 5 seconds.

● Stopwatch counter/Stopwatch memo

This watch is equipped with the stopwatch counter function which can count from 1 time to 99 times. Every time the stopwatch is stopped, the count No. and the time are indicated and up to nine latest data can be memorized.

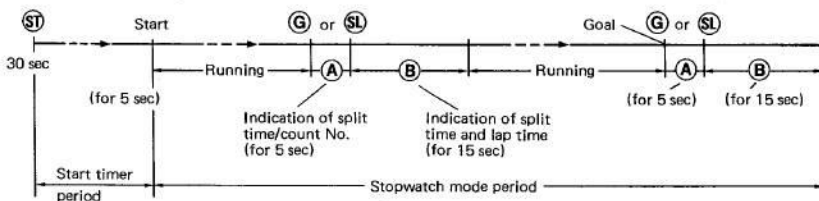
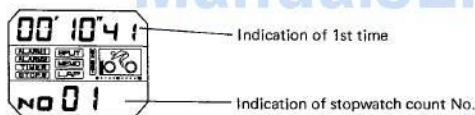

* The time at which the last split time is measured is memorized as the goal time when the stopwatch is stopped in total 20 seconds of **A** and **B** shown above.

(If a shock is given to the watch at the goal and the **ST** button is pressed in 20 seconds after that to stop the stopwatch, both goal time and count No. (number of times of training) are memorized.)

(However, since D132 has the split time memory function, it memorizes the count No. and the split time each time the split time is measured.)

● **Calling the memory**

- 1) After the watch is reset, the latest data in the memory is indicated every time the (SL) button is pressed. However, if no data has been memorized, the watch does not indicate any data even if the (SL) button is pressed.

(See [Calling the stopwatch memory] in page 7.)

Graphic display of memory addresses

This display method is common to all CAL. D13※ watches. If the memory is called, the memory data are lit up in the order of time from the earliest one. (If 10 or more data are stored, data No. 9 is the newest one.)

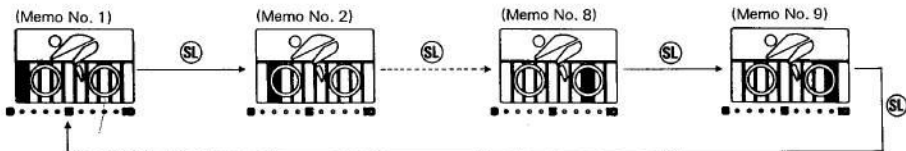

- 2) Only the latest nine data can be called. The data before those nine data are canceled automatically.

For example, when the user has practiced 15 times as shown below (time trial of 400-m course), the data to be memorized are as follows.

01	00'45''68	} Data automatically canceled	
02	00'46''58		
:			
:			
:			
06	00'50''00	} Data which can be called	
07	00'49''27		Memo No. 1
08	00'48''56		Memo No. 2
:			:
:			:
:			:
14	00'46''23		Memo No. 8
15	00'47''77		Memo No. 9

- 3) **Clearing all memorized data**

When the memorized data are called, if the (R) button is pressed one time, all the memorized data are deleted.

● **Lap time and split time**

Lap time: The time measured for a given section.

Split time: The time measured from the starting point.

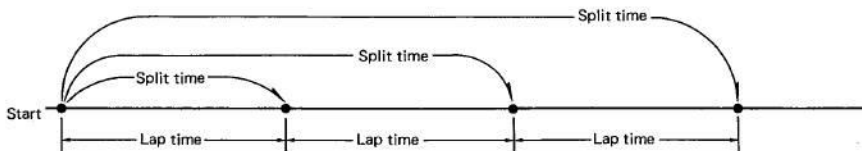

4-5. Example of stopwatch operation for Cal. No. D130 and D131

[Starting operation]

Even if you have some tools in both hands when starting a race, you can start the race according to the start timer sound.

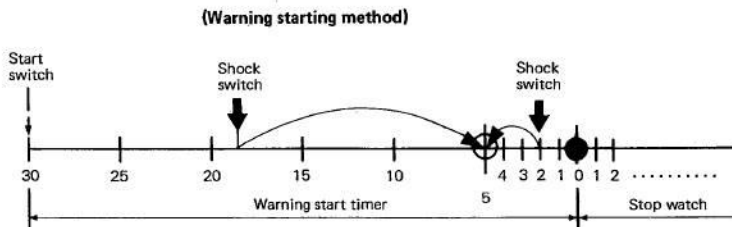

- (1) First, press the start button.
The stop watch starts 30 seconds after the button is pressed. Carefully prepare for the start.
- (2) After you are ready for the start, slap the watch with a part of your body.
- (3) At the time when the watch is slapped, it is set to 5 seconds before the start. (Even if it is not slapped, it starts automatically 30 seconds after.)
- (4) If you are a few seconds before the start, slap the watch again, and the stopwatch is set to 5 seconds before the start again. (This operation is not effective after the stopwatch starts.)
- (5) Start the race at the same time when the time-up (start) sound is heard.

[Stopping operation]

At the same time you have reached the goal, slap the watch.

- (1) Slap the watch with a part of your body at the same time you have reached the goal. The watch makes split alarm sound every second.
- (2) The split alarm sound continue for 20 seconds. During this time, the mark shown at right blinks.
- (3) Press the stop button during the above 20 seconds.
- (4) The time at the goal is stored in the memory.

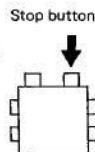

- (5) The number of trials is counted when the stop button is pressed.
- (6) Note that if the stop button is pressed 20 seconds or more after the time at goal, the time when the stop button is pressed is recorded.

After you have reached the goal, if you fall down or collide with something and a shock is given to the watch before the stop button is pressed, the data of the time at goal is lost.

[Split time measuring operation]

- (1) During a race, when checking the time, slap the watch with a part of your body.
- (2) The upper LCD of the watch displays the time after the start (split time) and the lower one displays the time after the previous split time (lap time) for 20 seconds.
- (3) Since the split time and lap time are not stored in the memory, they are not input in the memory even if you fall down or collide with something during the race.
- (4) During a race, the shock sensor may be turned on by some shock and the split time may be measured automatically.

In this case, the split time alarm sound is made. If you do not like to hear this sound, press the (S) button. The alarm sound is turned off. At this time, the part of "SA SET" shown below is blackened out.

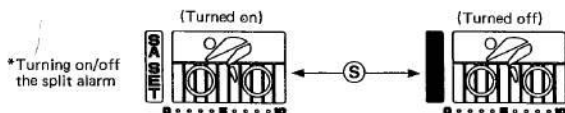

[Nine memories of stop time]

Every time the stopwatch is stopped, the time at each time is stored in the memory up to nine times. For example, if you have made 30 trials and stopped the stopwatch each time, the records of 22th trial through 30th trial are stored in the memory. Those records can be called by the following procedure:

- (1) Confirm that the stopwatch is stopped. (The time display or the graphic section stops.)
- (2) Press the (SL) button, and the watch is reset.
- (3) Press the (SL) button again, the record of the 22th trial is indicated as shown below.
- (4) Every time the (SL) button is pressed, the records of 23th trial and after are indicated in order. (At this time, the records are displayed in the graphic section from the oldest one.)

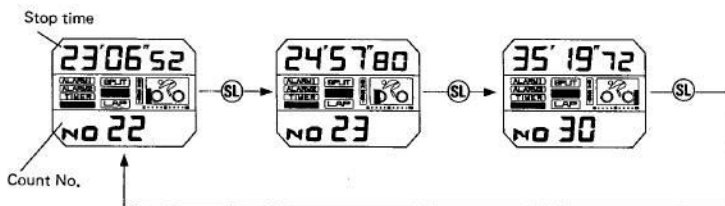

55. General check points

● Sound monitor

In alarm 1 or alarm 2 mode, if the (R) button is pressed and held, the sound monitor can be operated.

● Adjustment of time rate

While correcting the time and calendar, if the (R) button and (S) button are pressed at the same time, all the segments of LCD are turned on.

Under this condition, the time can be adjusted with the trimmer condenser.

All the segments are kept turned on for about two minutes, then the watch is automatically set to the time/calendar mode, or the display of all the segments can be returned to time/calendar mode by pressing any button.

● All reset operation



If the (R), (S), (ST), and (SL) buttons are pressed at the same time, all the modes can be initialized.

At this time, all the segments are turned on. If the buttons are released, the finish sound is made to notify all the modes to be reset.

All the data in the memory are canceled by the above operation, the necessary data must be recorded separately.

After the cell is replaced, be sure to perform this operation. If it is not performed, the watch may indicate time abnormally.

Indication in each mode after all reset operation

Normal time/Calendar mode: AM 12:00:00 12-hour system 1988, Jan. 01, Fri.

Alarm 1 mode: AM 12:00 Sounding turned off

Alarm 2 mode: AM 12:00 No day specified, sounding turned off

Timer mode: 00 min 00 sec

Stopwatch mode: Reset
Split alarm turned on
All memory in stopwatch cleared
Count number of split time: 00

● Replacement of power cell

A power cell for the use at low temperature is used for CAL. No. D131. When replacing the power cell, be sure to use the genuine one.

(Power cell No.)	(CAL. No.)	(Remarks)
280-204	D130, D132	Standard lithium battery
280-206	D131	Lithium battery for use at low temperature

• Composition of Basic Circuit and Principle

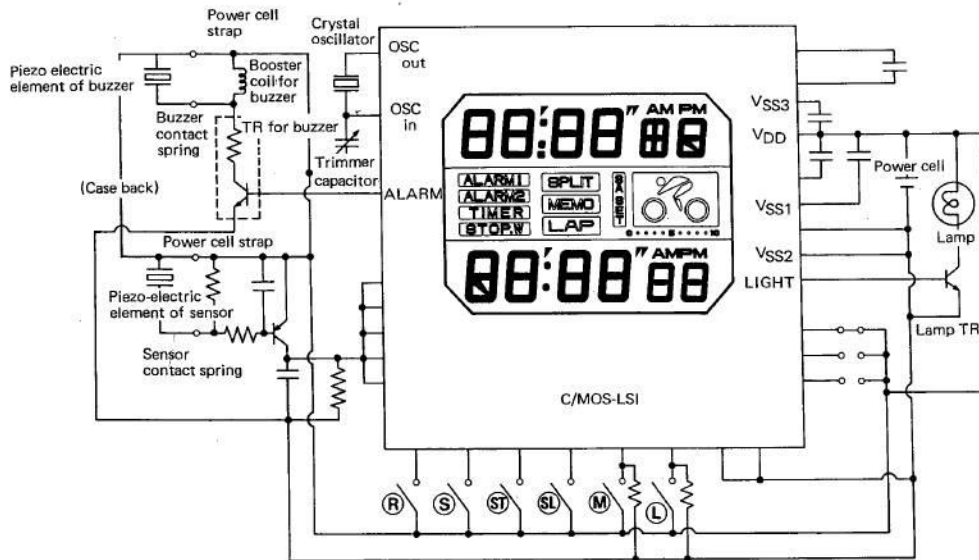

The outline of the operation of the shock switch is as follows:

Shock → Piezo-electric element of case back → Sensor contact spring → Transistor (Amplification of shock signal) → C/MOS LSI (Shock switch) → Change of display by shock/Alarm stops/Timer starts.

If a shock larger than the threshold value is given as shown in the following figure, a detection signal is generated to turn on the impact switch.

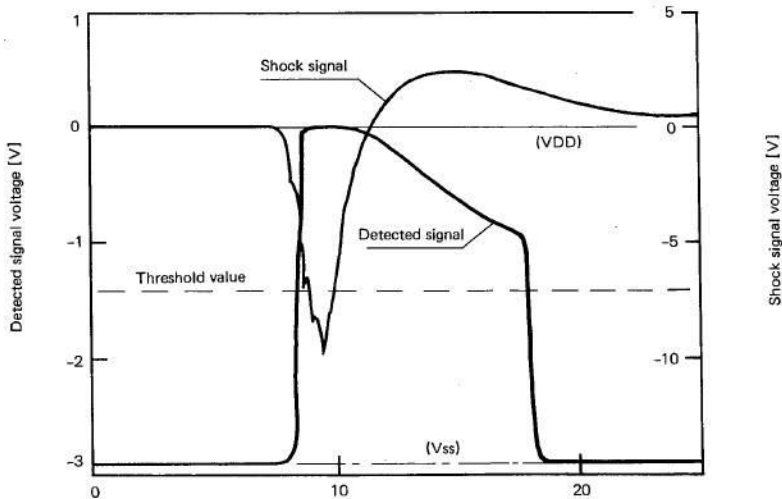

Shock signal and wave of detected impact signal Time [mSEC]

56. DISASSEMBLY AND ASSEMBLY OF THE MODULE

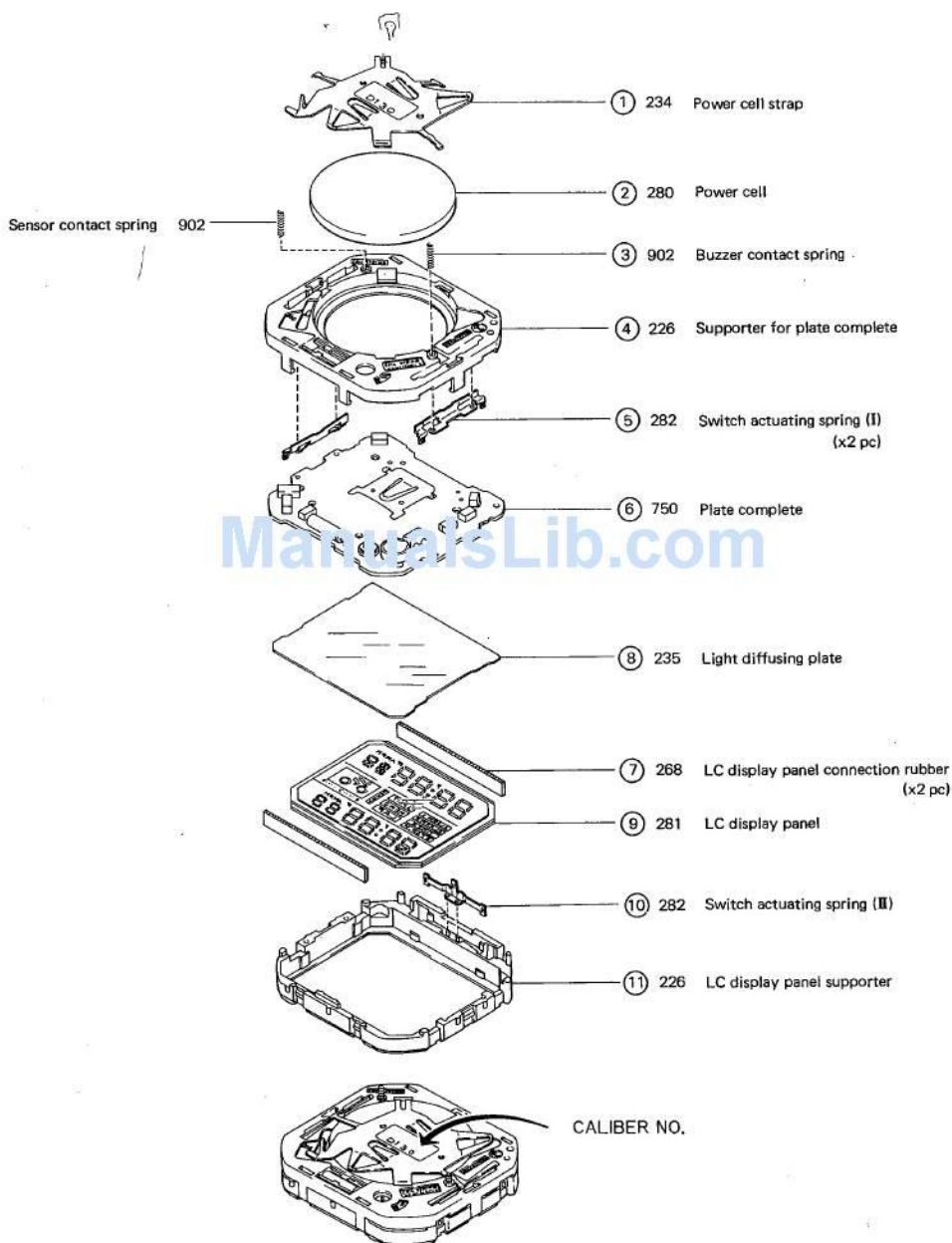

Disassembly procedure: ① → ⑪

Assembly procedure : ⑪ → ①

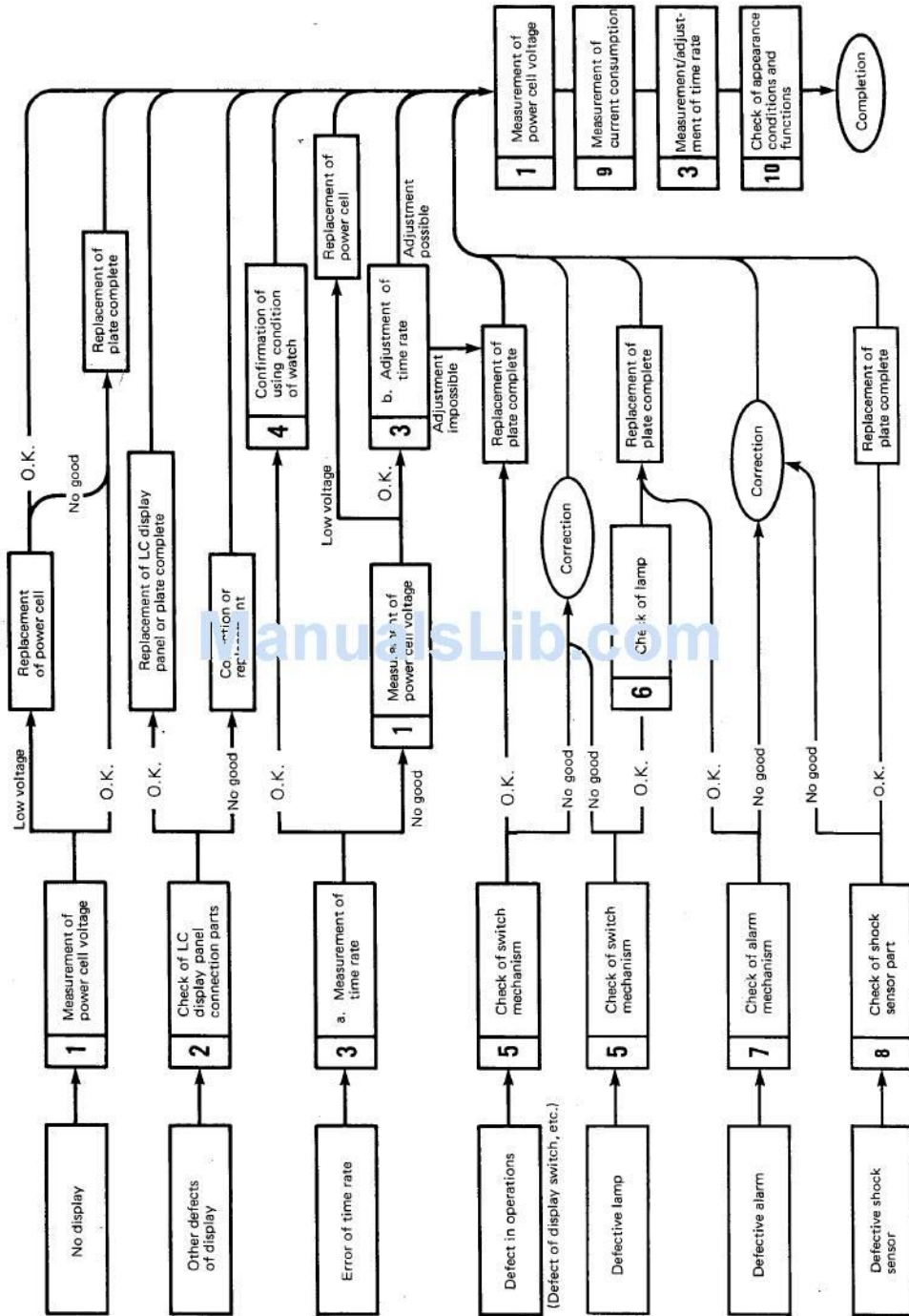

S7. TROUBLESHOOTING AND ADJUSTMENT

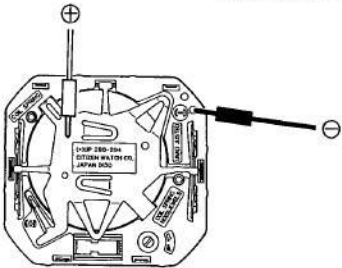

Check points	How to check	Results & treatment
<p>1 Measurement of power cell voltage</p>	<p>[Refer to Technical Manual Basic Course II-1-a for tester setting]</p> <p style="text-align: right;"><Tester range DC 12V ></p> 	<p>Over 2,8V → Nondefective</p> <p>Under 2,8V → Replace the power cell</p>
<p>2 Check of LC display panel connection parts</p>	<p>[Refer to Technical Manual Basic Course II-2-a-Digital Part]</p>  <p>● Checking all the segments; simultaneously push the (R), (S), (ST) and (SL) button, all segments are turned on while pushed. In the above condition, check for defective segments. This is the all-reset operation. (See 55 of 12 page)</p>	
<p>3 Measurement/ Adjustment of the time rate</p>	<p>[Refer to Technical Manual Basic Course II-2-d]</p> <p>Set the watch to correct time in the time/calendar mode and press the (R) and (S) buttons at the same time, and all the segments are lit up. During this period, the time rate can be measured. (See 55 of 12 page)</p> <p>a) Measurement of the time rate Measurement of the time rate can be made with the "MEASURE TIME" set at a range of 2 seconds.</p> <p>b) Adjustment of the time rate Turn the trimmer condenser clockwise.</p>	<p>Enables adjustment → Nondefective</p> <p>Does not enable adjustment → Replace the plate complete</p>
<p>4 Confirmation of using conditions of watch</p>	<p>[Refer to Technical Manual Basic Course II-2-e]</p> <p>Check to see if the handle is operating correctly or not.</p>	

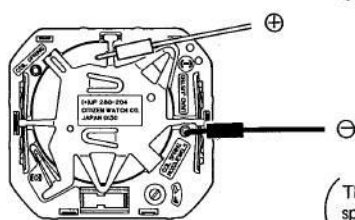
Check points	How to check	Results & treatment
<p>5 Check of switch mechanism</p>	<ul style="list-style-type: none"> • Check whether the pattern of the plate firmly contacts the switch actuating spring. • Check whether the push buttons has not been deformed and has no dust or dirt on it. <p>*To maintain the waterproof of the watch and the smooth operation of the buttons, be sure to put silicone oil on the push button packing.</p>	
<p>6 Check of lamp</p>	<p>[Refer to Technical Manual Basic Course II-1-e for tester setting]</p>	<p>Flashing → Nondefective</p> <p>Not flashing → Replace the plate complete</p>
<p>7 Check of alarm mechanism</p>	<p>[Refer to Technical Manual Basic Course II-1-d for tester setting]</p> <ol style="list-style-type: none"> Checking the piezo-electric element If the white color piezo-electric element attached directly to the case back with adhesive, especially the part touching by the buzzer contact spring, have a defect or a crack, the alarm may not sound. Checking the buzzer contact spring Check whether the buzzer contact spring is bent/deformed or not. Checking alarm output signal of plate complete (You can check without removing the module from the case.)  <p><Tester range DC 0.3V></p> <ul style="list-style-type: none"> • In the alarm monitor mode, ⊕ ... to the power cell surface ⊖ ... to the buzzer contact spring. 	<p>Tester pointer oscillating → Nondefective</p> <p>No oscillating → Replace the plate complete</p>

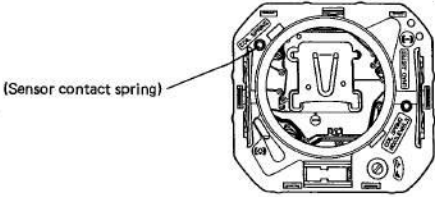
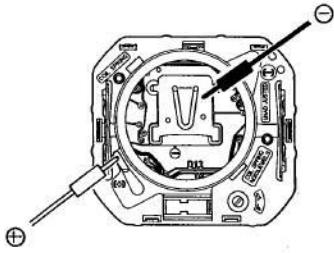
Check points	How to check	Results & treatment
<p>8 Check of shock sensor part</p>	<p>(Case back)</p> <ul style="list-style-type: none"> ● Check the Piezo-electric element for cracking and removal. ● Confirm the case back is fitted in the correct direction. <p>(Sensor contact spring)</p> <ul style="list-style-type: none"> ● Check the spring for bend and deformation. ● Confirm the spring is in contact with the plate complete. <p>(Giving method of shocks)</p> <ul style="list-style-type: none"> ● Confirm shocks are given correctly from the direction of the glass of the watch. ● Confirm given shocks are too weak. (See 53, page 3) 	<ul style="list-style-type: none"> ● There is not abnormality, but the shock sensor does not work. <p>→ Replace the plate complete</p>
<p>9 Measuring the current consumption</p>	<p>[Refer to Technical Manual basic course II-1-f for tester setting]</p> <p><Tester range DC 12μA></p>  <p>Note: When measuring the current consumption, be sure to perform the all-reset operation. If it is not performed, the current consumption may not be measured correctly.</p> <p>Influence of light</p> <div style="border: 1px solid black; padding: 5px;"> <p>Avoid measuring current consumption under an incandescent lamp or the direct rays of the sun, because it may cause the current value to increase.</p> </div>	<ul style="list-style-type: none"> ● Current value of the complete module after all reset operation <p>Under 2.4μA</p> <p>→ Nondefective</p> <p>Over 2.4μA</p> <p>Singularly measure the unit of the plate complete for current value</p> <ul style="list-style-type: none"> ● Current consumption when all elements are lit up <p>Under 3.5μA</p> <p>→ Nondefective</p> <p>Over 3.5μA</p> <p>→ Replace the plate complete</p> <p>(Light up all the elements according to 55 adjustment of time rate, page 12)</p>
<p>10 Check of appearance conditioning and functions</p>	<p>[Refer to Technical Manual Basic Course II-2-f]</p> <p>Check whether the displays and buttons operate correctly or not in the complete condition.</p>	