

## §1. OUTLINE



This is a digital quartz watch incorporating the electronic alarm, which has been developed by the Citizen's superb precision technique that made possible to market the electronic alarm for the first time with Cal. No. 902-series watches.

It especially features the multiple function along with the increment of information quantity. The display part is capable of the unique "2-tier simultaneous display" through which the normal time display plus another mode display are always possible at one time.

## §2. FEATURES

- 1) The multiple function includes alarm-1, alarm-2, stopwatch, timer, time signal plus alarm monitor.  
The alarm tone differs according to the alarm-1, alarm-2, timer respectively.
- 2) The display part features the unique 2-tier simultaneous display system: the normal time is always displayed in the upper display screen along with another selected mode displayed in the lower screen respectively and at one time.
- 3) For the timer, the repeat function is added newly to ring the alarm at every set time and in any times as desired in addition to the memory function which memorizes the set time.
- 4) The calendar can be corrected automatically including even the leap years after once set correctly.
- 5) The power cell life indicator lets the user know the time to replace the power cell through flashing of the colon on the display screen.
- 6) The built-in illumination lamp facilitates an easy reading of the information displayed on the screen even in a dark place.
- 7) The watch of the front mode-button type arranges each mode button in front of the watchcase, thus facilitating call-out of each mode through one-touch operation.

§3. SPECIFICATIONS

Caliber No.		9200A
Type		Digital quartz crystal watch with LC display
Movement		Diameter: 27mmφ
		Thickness: 5.15mm
Oscillation		32,768Hz
Accuracy		±10 sec./month at normal temperatures
Display system		<ul style="list-style-type: none"> <li>●LC display by FE twist-type nematic</li> <li>●2-tier simultaneous display by matrix</li> </ul>
Display information	Time display	Hour, Minute, second, AM/PM
	Calendar	Month, date, day plus year (at display correction time)
	Alarm-1	Hour, minute, A/P
	Alarm-2	Hour, minute, A/P
	Stopwatch	Minute, second, 1/100 sec.
	Timer	Hour, minute, second
Effective temperature range		0°C ~ +60°C (32°F ~ 140°F)
Additional mechanisms		<ul style="list-style-type: none"> <li style="width: 50%;">●Alarm-1</li> <li style="width: 50%;">●Alarm monitor</li> <li style="width: 50%;">●Alarm-2</li> <li style="width: 50%;">●Illumination lamp</li> <li style="width: 50%;">●Stopwatch</li> <li style="width: 50%;">●Power cell life indicator</li> <li style="width: 50%;">●Timer</li> <li style="width: 50%;">●Automatic calendar setting device</li> <li style="width: 50%;">●Time signal</li> <li style="width: 50%;">●Quick resetting device</li> </ul>
Power cell		<p>Silver oxide power cell (Parts No. 280-15)</p> <ul style="list-style-type: none"> <li>●Nominal voltage : 1.55V</li> <li>●Capacity : 75mAH</li> <li>●Size : 11.6mmφ x 3.1mm</li> <li>●Life : About 2 years (5 sec. of lamp glow and 90 sec. of alarm ring per day)</li> </ul>

§ 4. HANDLING INSTRUCTIONS

1 Side mode-button type

(1) Nomenclature

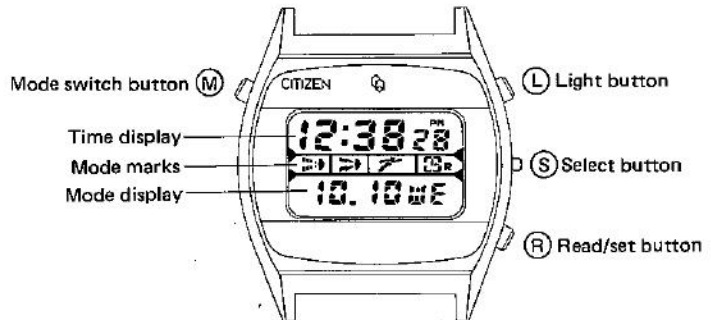

(2) Display switching

The normal time display is given constantly on the upper display screen, and the display mode on the lower screen changes with every push of (M) button. The mode mark also changes along with the switch of the display on the lower screen to indicate the kind of the displayed mode.

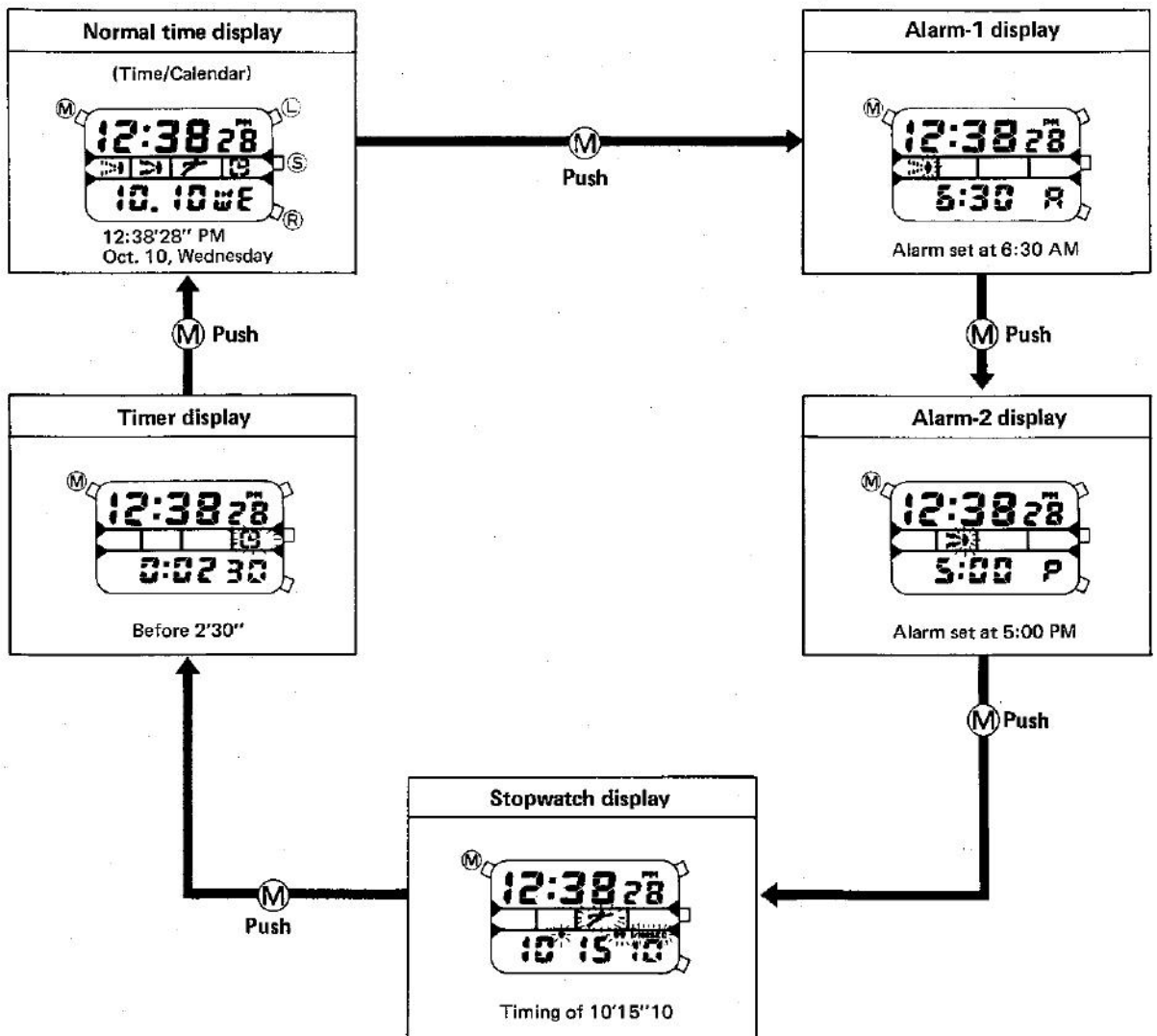

2 Front mode-button type

(1) Nomenclature

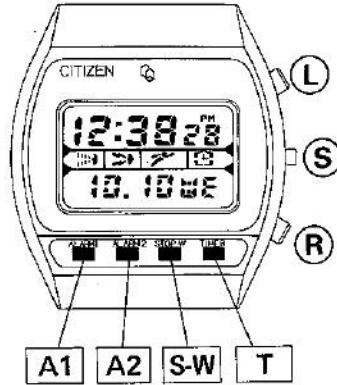

- A1** Alarm-1/Calendar
- A2** Alarm-2/Calendar
- S-W** Stopwatch/Calendar
- T** Timer/Calendar

(2) Display Switching

In this type, the desired function mode can be called out through the one-touch operation of the mode buttons.

For instance, "Alarm-2" is desired, it can be displayed quickly just by pushing **A2** button. And, **T** button is pushed to call out "Timer".

The "Calendar" can be displayed with push of the button corresponding to the mode displayed then, that is, for example, the calendar is displayed with push of **S-W** button the stopwatch time is displayed.

However, under the time setting state of each mode, the mode displayed is not changed to another.

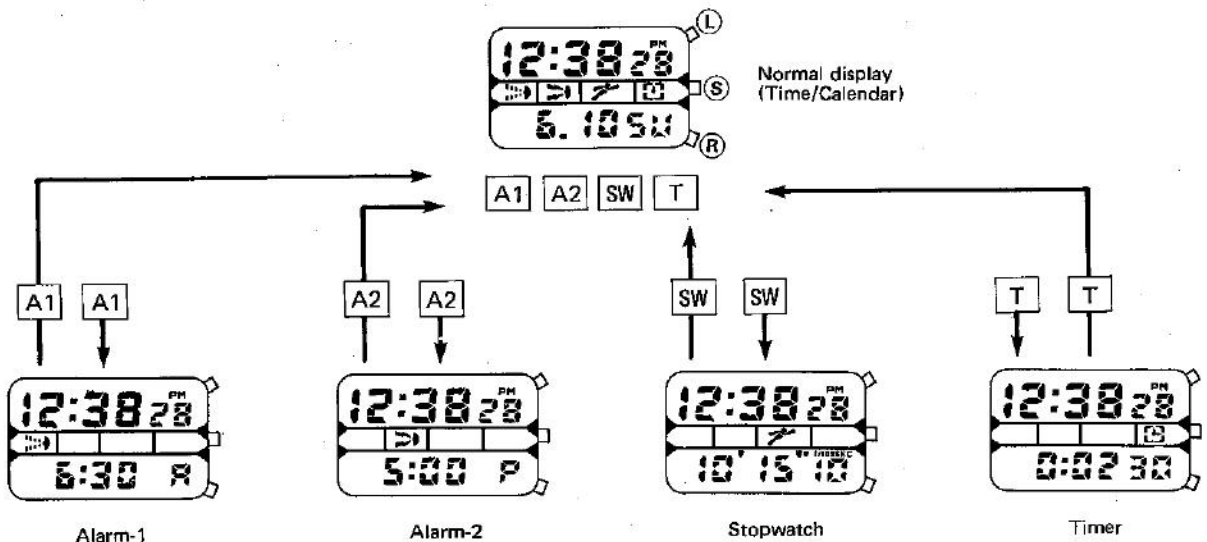

### 3 Setting of time and calendar

The display area to be corrected is called out with flashing by pushing **(S)** button, and then the setting is performed with push of **(R)** button in the order of ①~⑰. (The flashing is indicated by the mark of ✨.)

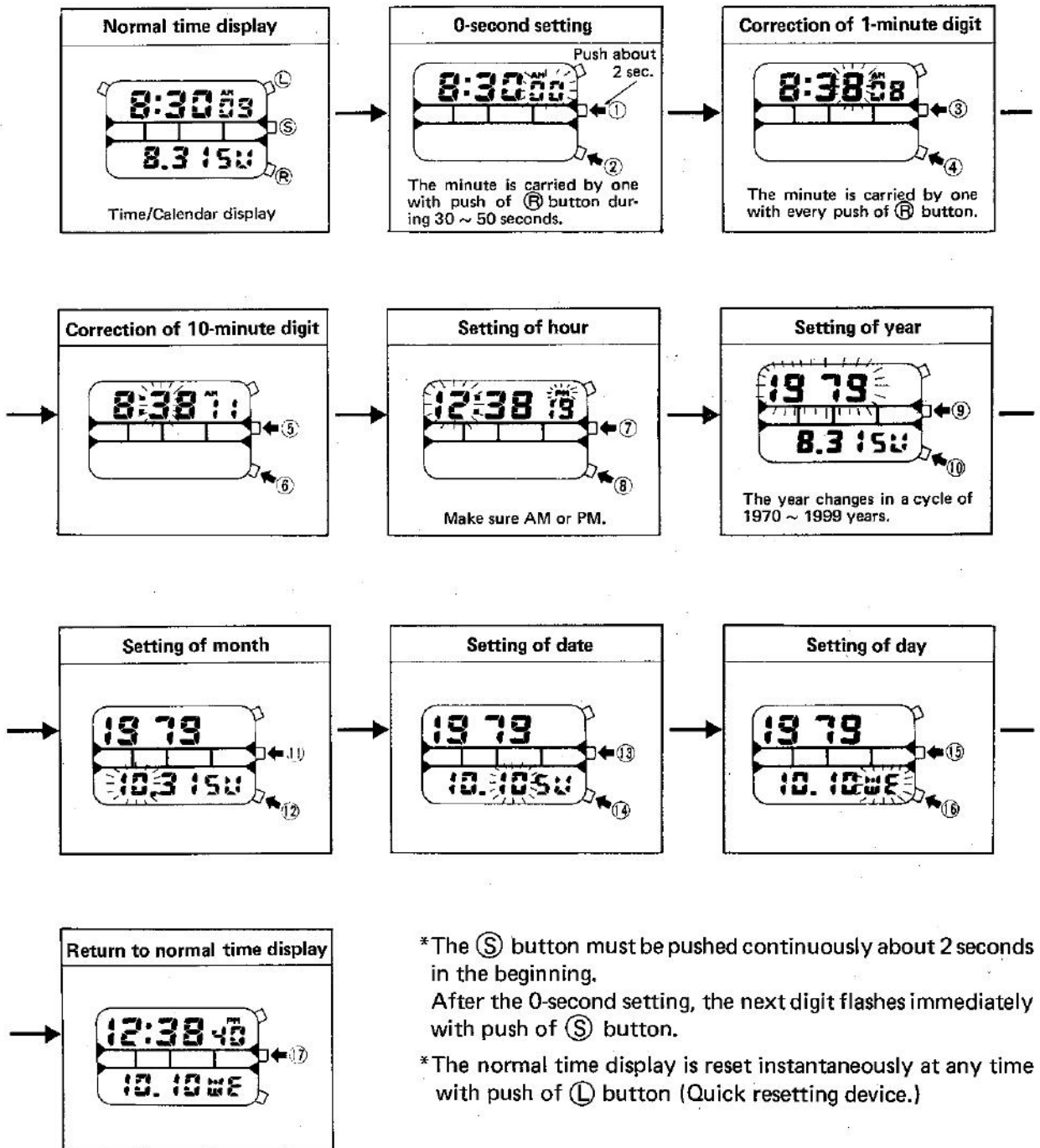

- \*The **(S)** button must be pushed continuously about 2 seconds in the beginning.  
After the 0-second setting, the next digit flashes immediately with push of **(S)** button.
- \*The normal time display is reset instantaneously at any time with push of **(L)** button (Quick resetting device.)

4 Operation of alarm-1

The alarm-1 mode is called out from the normal display (lower display screen) with one push of M button.

- ◆ : Alarm-1 mode mark
- ⦿ : Alarm-1 set mark
- \*The other mode marks disappear and ◆ mark flashes when alarm-1 is displayed.

(1) Time setting with alarm-1

The area to be corrected is called out with push of S button, and then the time is set via R button.

(In the following diagrams, the time displayed on the upper screen is given just as an example and thus has no relation with the alarm time shown on the lower screen.)

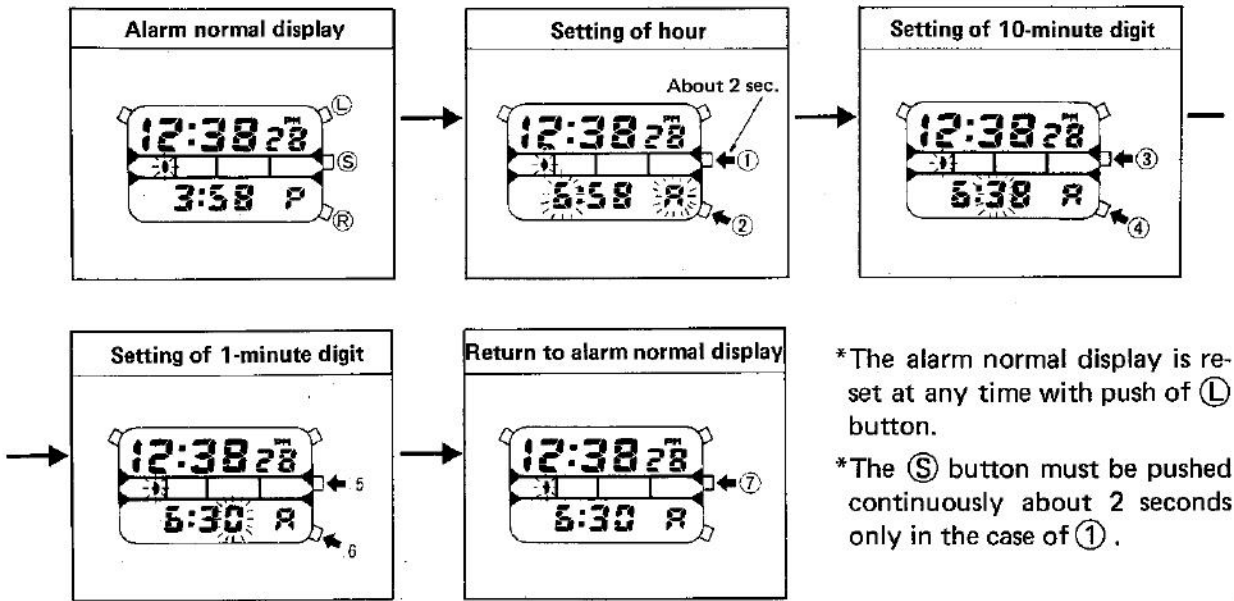

(2) Set/Cancel of alarm-1

The alarm is set and cancelled alternately with every push of R button under the alarm normal display mode.

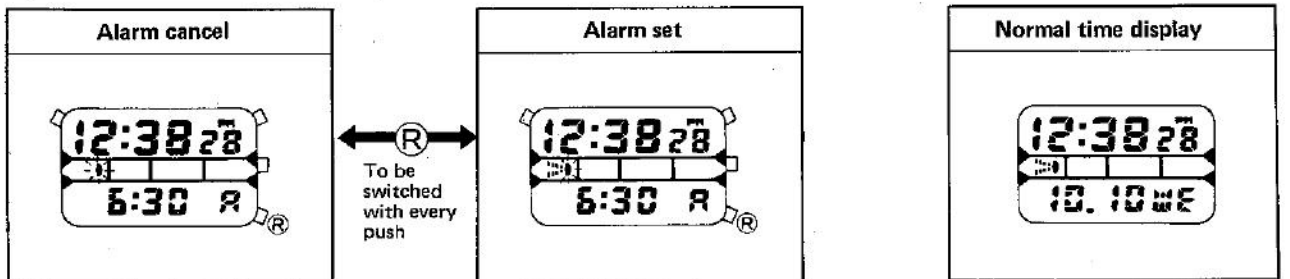

\*When the normal time display is reset under the alarm set state, ⦿ mark is displayed.

5 Operation of alarm-2

The operation of the alarm-2 is identical to that of the alarm-1 except for the marks below.

- ◆ : Alarm-2 mode mark
- ⦿ : Alarm-2 set mark

\*The alarm ring is stopped with push of either of the push-buttons.

6 Operation of stopwatch

↔ : Stopwatch mode mark (Flashing constantly under the stopwatch display mode)

LAP : Lap mark

▼▼▼ 1/100SEC: Run mark (Flashing under the run state of run or lap run)

(1) Resetting method

The stopwatch must be reset before start.

The following five modes (① ~ ⑤) are displayed in the stopwatch operation.

(The time displayed on the upper screen is just an example and has no relation with the stopwatch time on the lower screen.)

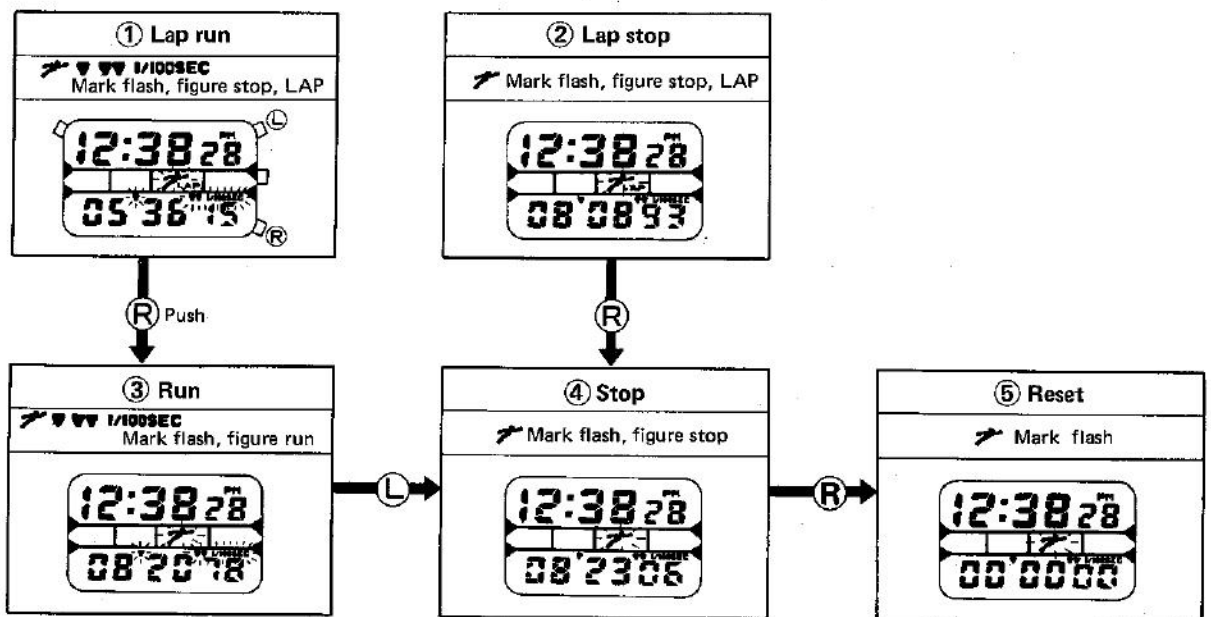

(2) Simple timing and integrating timing

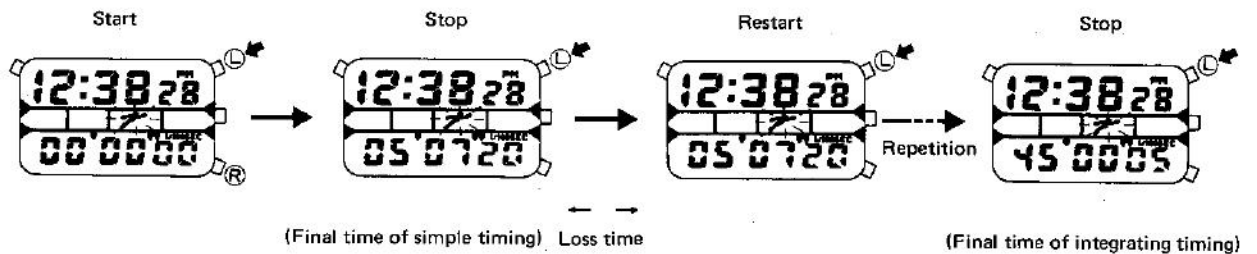

(3) Lap-time timing

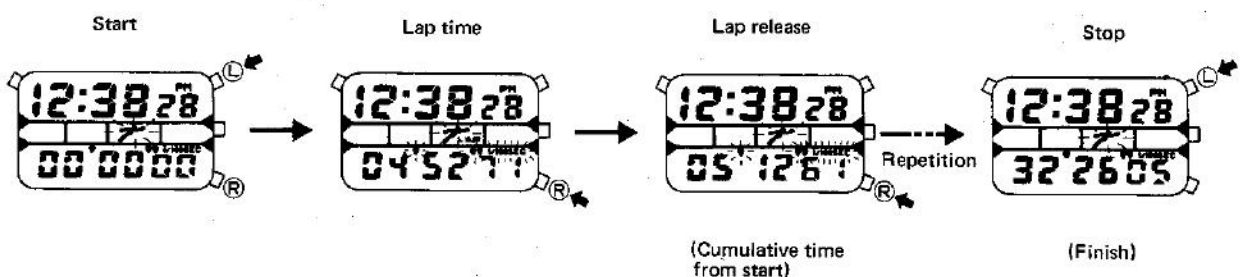

(4) Timing of 1st and 2nd winners

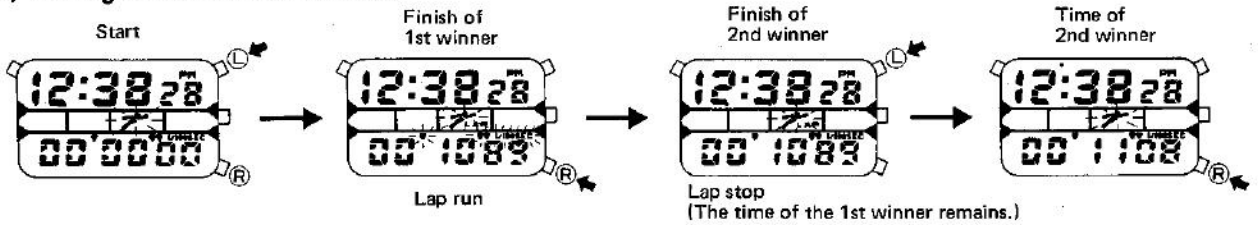

\*The timing is still kept even in case the display is switched to other mode under timing (run or lap run), and mark is displayed when the normal time display is reset.  
 \*The alarm rings once with every push of button for confirmation of start and stop of timing.  
 (Note) Under the stopwatch display mode, the light does not glow even with push of button.

7 Operation of timer

The outstanding feature of the timer is that the time once set is memorized until the next time is set.  
 Furthermore, the repeat function is added newly, that is, the alarm rings every set time in any times. For instance, if the alarm is set to 5 minutes, it rings at every 5 minutes.

(1) Setting method of timer

The timer must be set under the timing stop state. So in case the timing is being carried out, the timing is stopped with push of button. As in the case of other modes, the setting is permed via button after calling out the area to be set. However, the correction or setting of the timer is carried out in the subtraction method unlike other functions.

For example, the "hour" is set as 0 → 11 → 10 → 9 → 8 ... 2 → 1 → 0 and so on.

- : Timer mode mark (flashing constantly under timer mode)
- R : Repeat set mark

(In the following diagrams, the time shown on the upper screen is just for example and has no relation with the timer set time on the lower screen.)

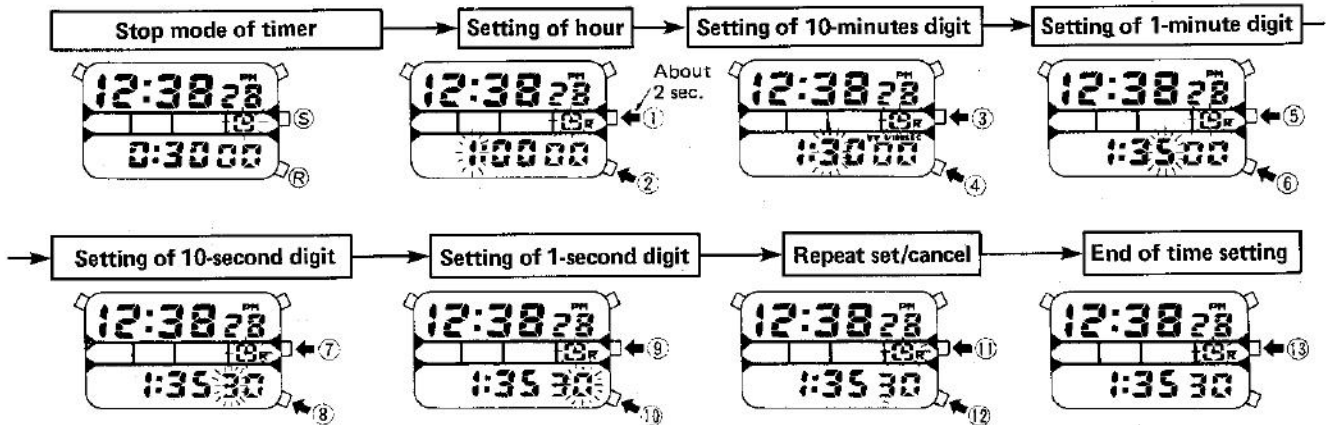

\*The time set end state can be secured at any time with push of button.  
 \*The set and cancel of the repeat function are switched alternately with every push of button.  
 Repeat set: Both and -R marks flash at one time.  
 Repeat cancel: The and -R marks blinks alternately.  
 When the setting is over, the mark is displayed under the repeat set state, and only mark is displayed when the repeat is cancelled respectively.

(2) Method of timing

① When the time setting is over, the timer is started with push of (L) button.  
 When (L) button is pushed under timing, the timing is stopped and then starts again with the second push of (L) button.  
 Thus, such repetition of timing can be applied to the soccer game or the like.  
 The set time is reset with push of (R) button regardless of timing or non-timing. And in the case of timing, the timing is started again as soon as the set time is reset.

② Repeat set

When the reset time becomes 0 second (0-second detection), the alarm rings.  
 In this case, the set time is reset and started again simultaneously with the 0-second detection. The alarm rings once with the 0-second detection in case the set time is within 59 seconds, and rings for 10 ~ 20 seconds simultaneously with the 0-second detection in case the set time is more than 1 minute and 00 second respectively.  
 In that case, the set time is reset and started again. And if (L) button is push to stop the alarm ringing, the timing is carried out as before although the alarm function is stopped. In other words, the highest priority is given to the function to stop the alarm ringing among other switching function.

\*Under the timer mode, no light glows even with push of (L) button.

\*With push of (L) button, the confirmation tone is heard for the start and stop of the timing.

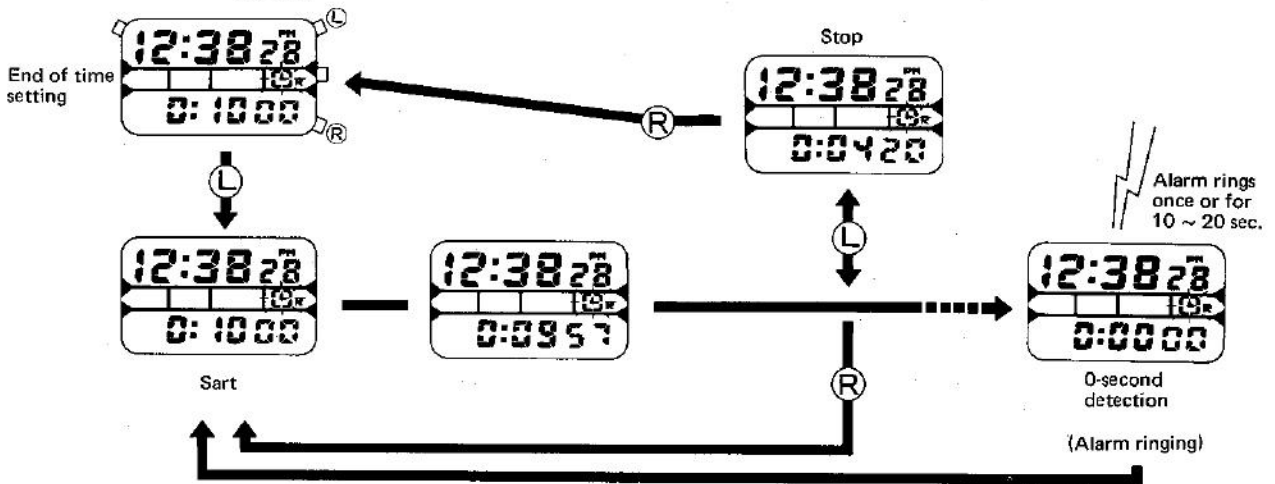

③ Repeat cancel

The alarm rings for 10 ~ 20 seconds simultaneously with the 0-second detection and irrespective of the set time. And the set is reset as soon as the alarm ringing ends (also in case the ringing is stopped forcibly with button operation). In this case, the timing is not started again but the stopping state is continued.

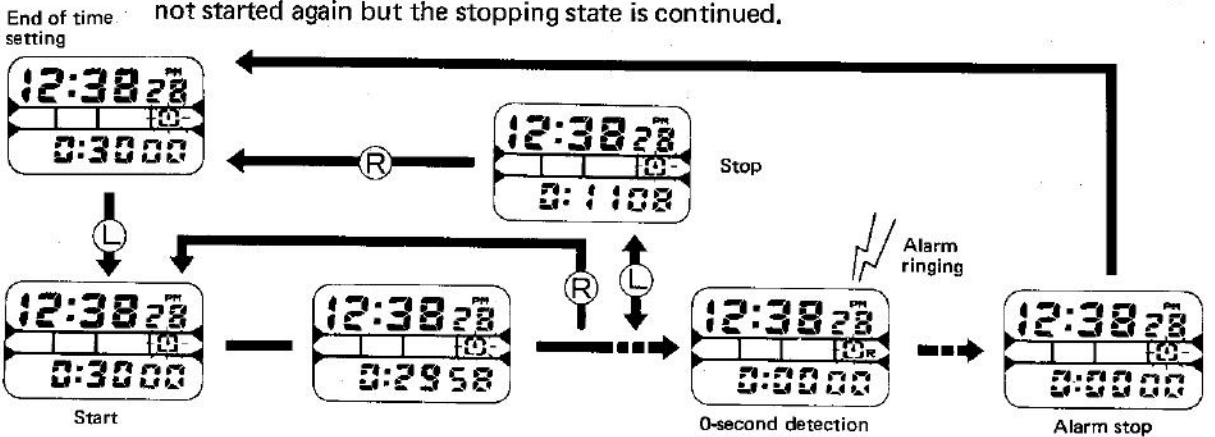

## 8 Time signal and alarm monitor

With simultaneous push of (L) and (R) buttons, the alarm rings regardless of the mode functioning (Alarm monitor). In this case, the alarm rings continuously until the both buttons are released or rings short once even if the both buttons are pushed continuously. This proceeds directly to the set and cancel of the time signal.

In other words, the long ring is the time signal set and the short one is the time signal cancel respectively.

With setting of the time signal, the alarm rings twice at every hour on the hour.

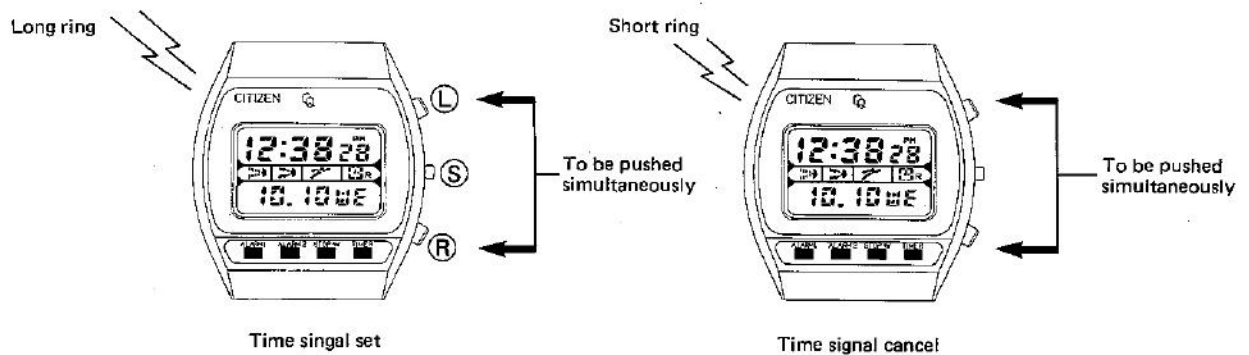

## 9 Types of alarm ringing

The alarm ringing differs to each mode as follows.

- Alarm-1  
Rings continuously 60 times (60 seconds) in a trembling way.
- Alarm-2  
Rings short twice in 60 times in all.
- Time signal  
Rings short twice every hour on the hour.
- Reciprocal timer  
Rings long in 10 ~ 20 times.  
(However, the alarm rings just once simultaneously with the 0-second detection in the case of the set time less than 59 seconds with the repeat rest.)

The alarm ringing can be stopped with push of either one of the push-buttons. In this case, no other mode is switched on. However, only the light glows in all function modes other than the stopwatch and the timer.