SERVICE MANUAL

(with price)

ELECTRONIC CASH REGISTER

110CR/PCR250 (EX-266)

150CR (EX-267)

JAN. 1995

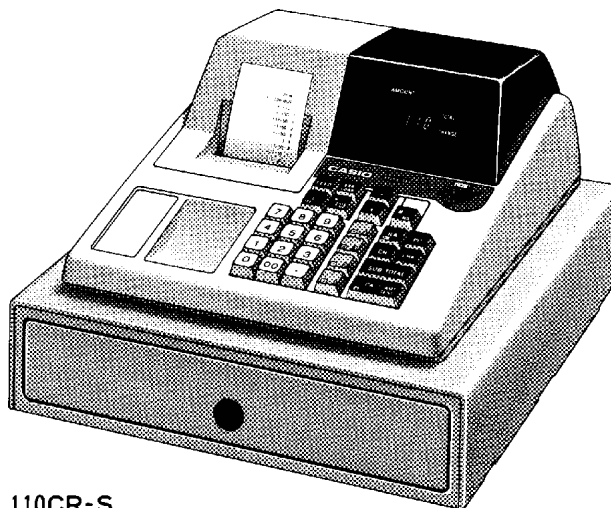

110CR-S

Printer Model : M42V

CASIO®

CONTENTS

	Page
1.FEATURES	1
2.SPECIFICATIONS	1
3.OPTION	2
4.MAC OPERATION	2
5.BLOCK DIAGRAM	3
6.CIRCUIT EXPLANATIONS	4
6-1. Power supply circuit	4
6-2. Reset circuit	5
6-3. Data communication between CPU and EEPROM	6
6-4. Printer drive circuit	8
6-5. Pin description	9
7.DISASSEMBLY	10
7-1. To open the upper case	10
7-2. To remove the Main PCB	10
7-3. To remove the keyboard ass'y	10
8. DIAGNOSTOC OPERATIONS	11
9. IC DATA	16
9-1. LB1268	16
9-2. S-80728AN-Z	16
10.CIRCUIT DIAGRAM	17
11.PCB LAYOUT	28
12. PARTS LIST	29

1. FEATURES

Function	110CR	PCR-250	150CR	150CR (U.S.A.,Canada)
Department number	4	8	4	8
PLU function	Nil	16	Nil	16
Customer display	Nil	Nil	Effective	Effective
PRG data back up function	Effective	Nil	Effective	Nil
Calculator function	Effective	Effective	Effective	Effective

2. SPECIFICATIONS

110CR/PCR-250

Power consumption	In operation	Max.	4.5W	100V	120V	220V	230/240V
		Stand-by	-	0.08A	0.09A	0.04A	0.05A
				0.05A	0.06A	0.03A	0.04A
	Mode SW OFF		-	0.04A	0.05A	0.02A	0.03A
Memory protection	Backup battery	Mangan battery UM-3 x 3 pcs. (25°C)					
	Backup period	1 year (25°C)					
	Battery life	Replace every 1 year					
Clock and calender	Accuracy	Within ±30 sec. per month					
	Auto calender	Effective until 2099 A.D.					
Environment	Operating temperature	0°C ~ 40°C					
	Operating humidity	10% ~ 90%					
	Storage temperature	-25°C ~ 65°C					
	Storage humidity	10% ~ 95%					
Printer	Model	M-42V					
	Print method	Print wheel selecting type serial printer					
	Print digits	12 digits (Amount 10 digits : Symbol 2 digits)					
	MCBF	700,000 lines					
Ink roller	Model	IR-40 (Purple)					
	Life	1,000,000 characters					
Roll paper	Type	Fine-quarity paper					
	Size	57.5±0.5 mm					
	Roll diameter	80 mm or less					
Drawer	S drawer (Coin 5/Bill 4)	DL-1313 (for U.S.A.)					
	S drawer (Coin 5/Bill 3)	DL-1817 (for except U.S.A.)					
	M drawer (Coin 5/Bill 4)	DL-2439 (for Europe, Other countries)					
	M drawer (Coin 8/Bill 4)	DL-2749 (for Europe,U.K. and Other countries)					

150CR

Power consumption	In operation		120V	220V	230/240V
		Max.	0.11A	0.05A	0.06A
		Stand-by	0.07A	0.04A	0.05A
	Mode SW OFF		0.06A	0.03A	0.04A
Memory protection	Same as 110CR				
Clock and calender	Same as 110CR				
Environment	Same as 110CR				
Printer	Same as 110CR				
Ink roller	Same as 110CR				
Roll paper	Same as 110CR				
Drawer	S drawer (Coin 5/ Bill 4)		DL-1313 (for U.S.A.)		
	S drawer (Coin 5/Bill 3)		DL-1817 (for Europe,U.K., germany,Other countries)		
	M drawer (Coin 5/Bill 4)		DL-2439 (for Europe, Canada, Other countries)		
	M drawer (Coin 8/Bill 4)		DL-2749 (for Europe,U.K., Other countries)		

3. OPTIONS (110CR/PCR-250/150CR)

- Wet cover WT-69

4. MAC OPERATION (Memory All Clear operation)

1. Set the Mode Switch to OFF.
2. Plug the power cord of the ECR off an AC outlet.
3. Remove the memory protection batteries.
4. Leave the ECR a few minutes and plug the power cord into an AC outlet.
5. Set the memory protection batteries.
6. Turn the Mode Switch to REG position.

5. BLOCK DIAGRAM

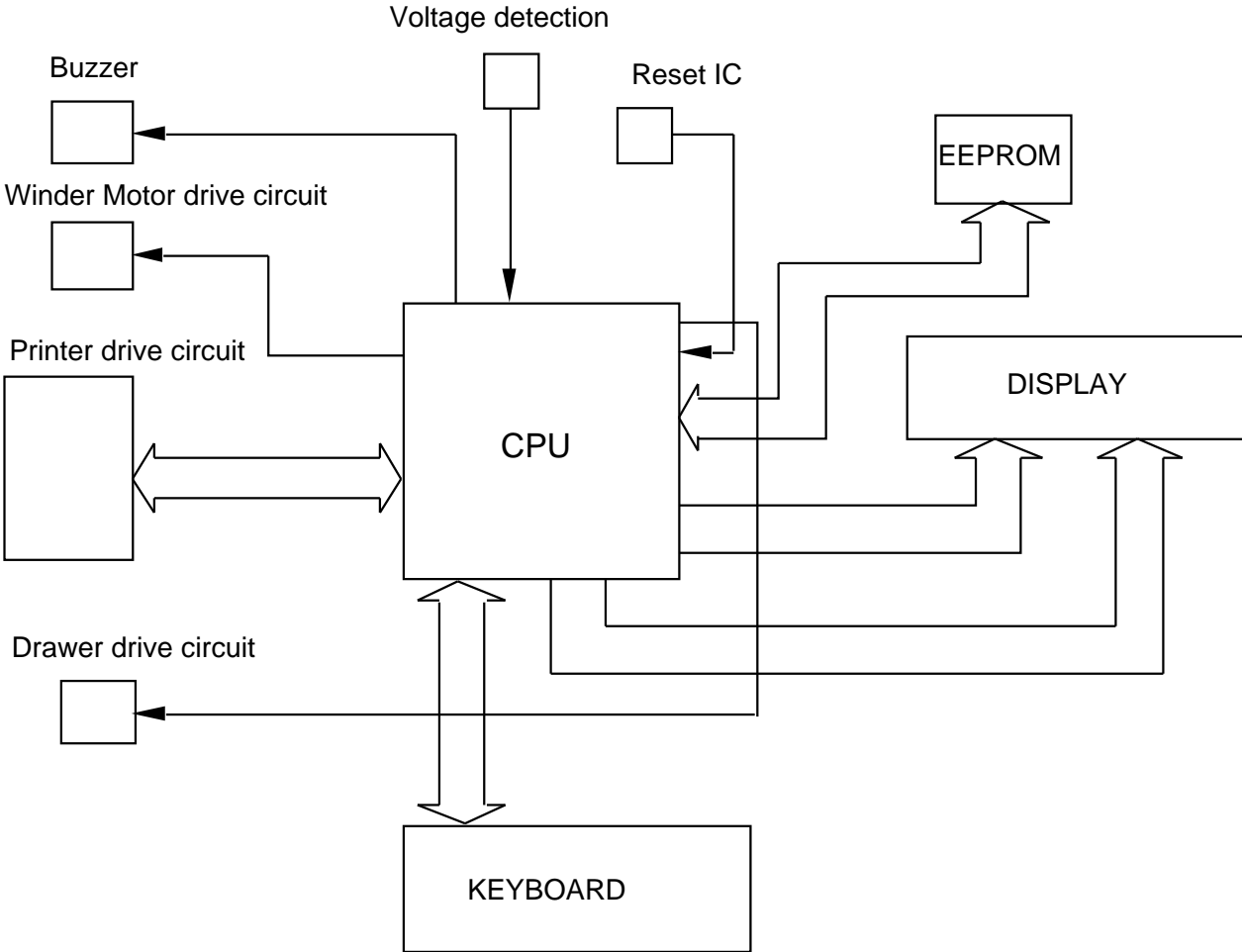

6. CIRCUIT EXPLANATION

6-1. Power supply circuit

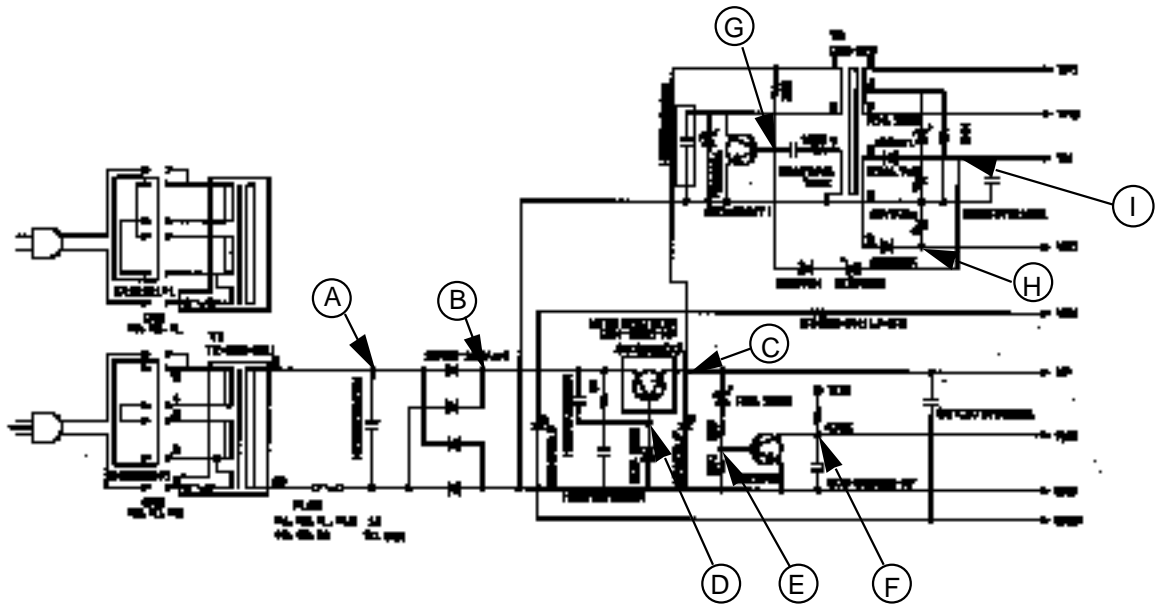

1. Plug the power cord into AC outlet, secondary voltage (9.65VAC) of the power transformer T1 will be appears at "A" point.
2. Then, its AC voltage is rectified by the diode bridge and change it to DC voltage. ("B" point)
3. DC voltage appears more than 7V at the corrector of power transistor 2SD2396, and then the power transistor is turned on.
Then VP is supplied. ("C" point)
4. When the VP voltage becomes more than 3.3V, the transistor 2SD945 is turned on and then PWD signal becomes GND level. ("F" point)
When the PWD signal becomes GND level, CPU knows no power failure.
5. VP is supplied at the DC DC converter trans T2, the DC DC converter makes display and logic circuit voltage.
VN ,VF1,VF2 : Display voltage ("I", "J" point)
VDD : Logic circuit voltage ("H" point)

Transistor 2SD1803 is used for oscillating the primary voltage of DC DC converter trans.

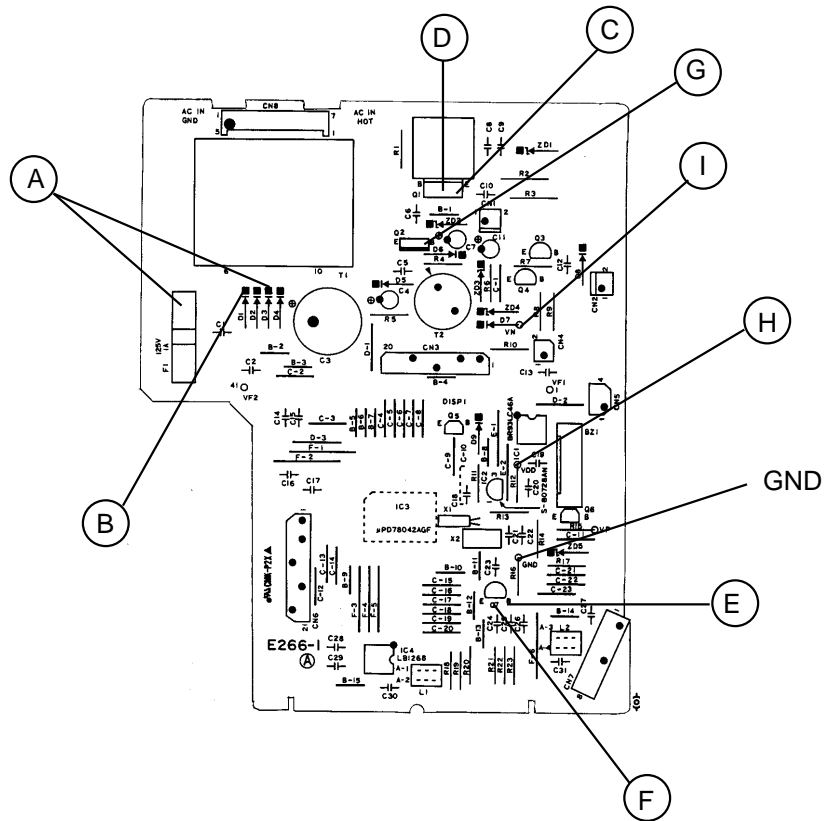

	A	B	C	D	E	F	G	H	I
Power ON	9.65 VAC	10.52V	5.76V	10.45V	0.78V	0.12V	Pulse	5.07V	-23.9V
Plug out	0	0	0	0	0	4.13V	0	4.30V	0

Voltage level is measured at the following condition.

1. Plug the power cord in AC outlet.
2. Mode switch position : REG, display 0.00
3. Put in the memory protection batteries.
4. Plug out : Plug out the power cord , the memory protection batteries in.

6-2. Reset circuit

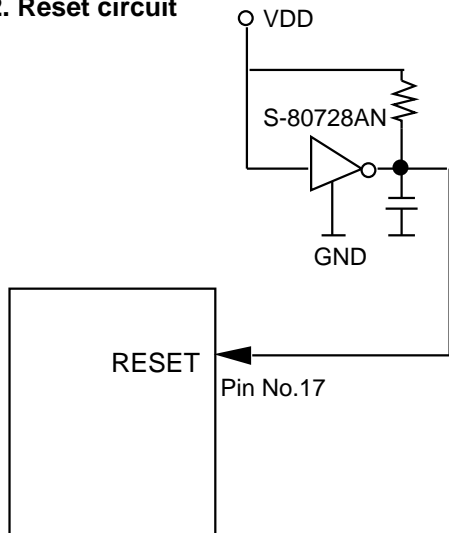

When the voltage level at the pin no.17 of CPU is not stable, CPU does not work properly. To make a stable voltage, the reset IC(S-80728AN) is used for this circuit. In case the voltage level of VDD becomes down output terminof reset IC is out the stable voltage.

6-3. Data communication between CPU and EEPROM

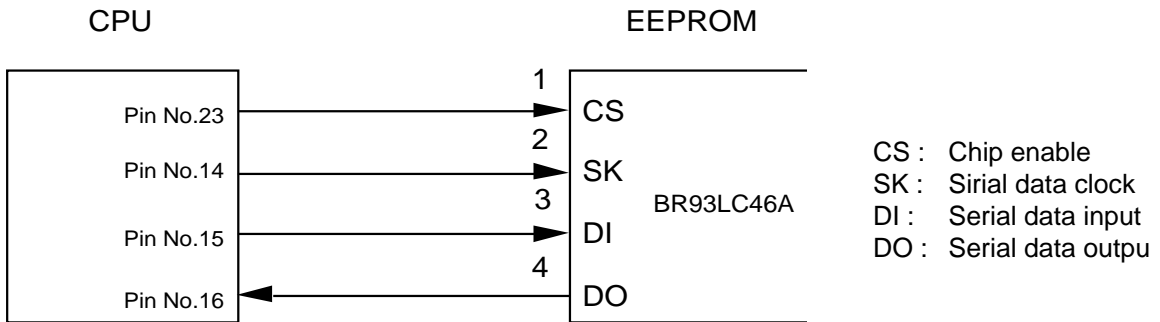

EEPROM is a memory to possible write/erase by electricity .
 The BR93LC46A provides efficient nonvolatile read/write memory arranged as 64 registers of 16 bits each.
 (64 words X 16 bits = 1024 bits)

[Block diagram]

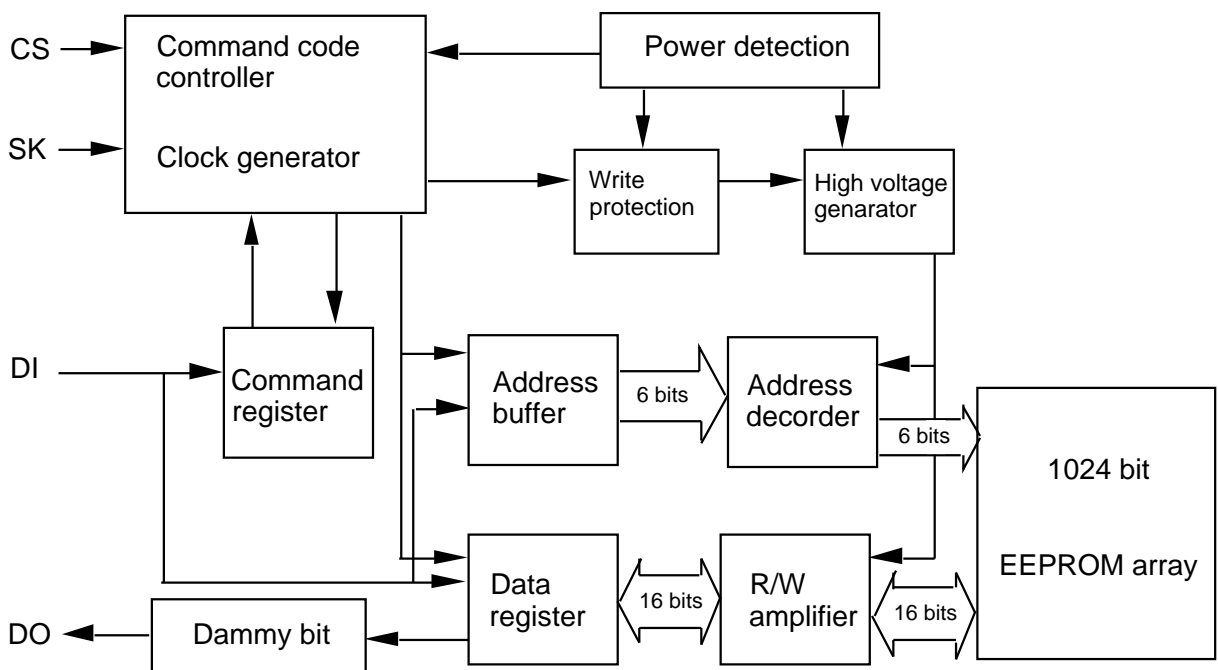

[Data reading procedure]

When the CPU read the data of EEPROM, CPU send the CS signal and SK signal to EEPROM. Then, CPU send the address to EEPROM, and then EEPROM send the data to CPU.

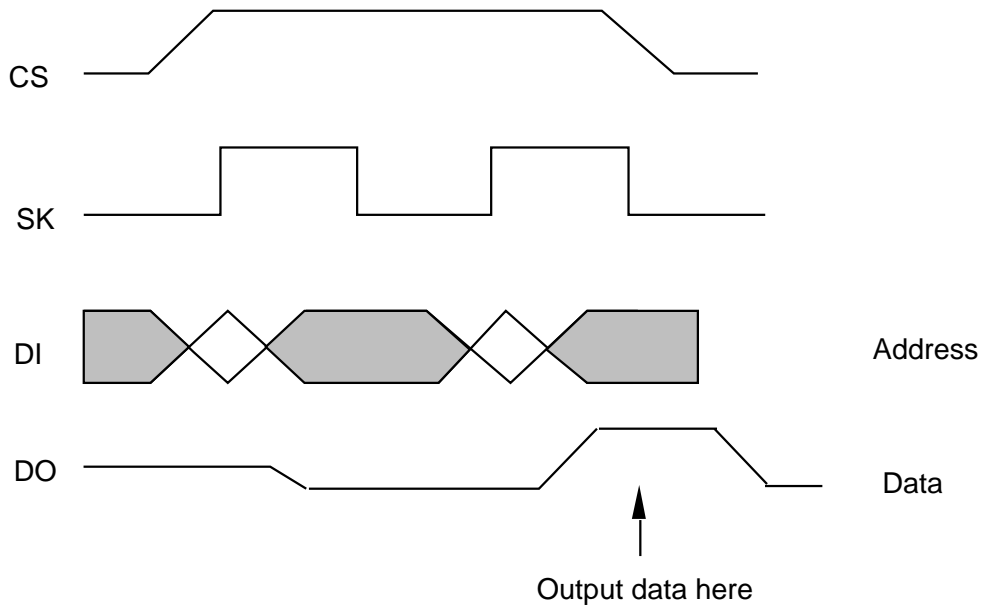

[Data writing procedure]

When the CPU save the data to EEPROM, CPU sends the CS and SK signal to EEPROM. And CPU send the address and data to EEPROM from pin No.15. When the EEPROM writes the data , EEPROM outputs the busy signal from DO terminal to CPU. After finish writing, EEPROM outputs the ready signal from DO terminal to CPU.

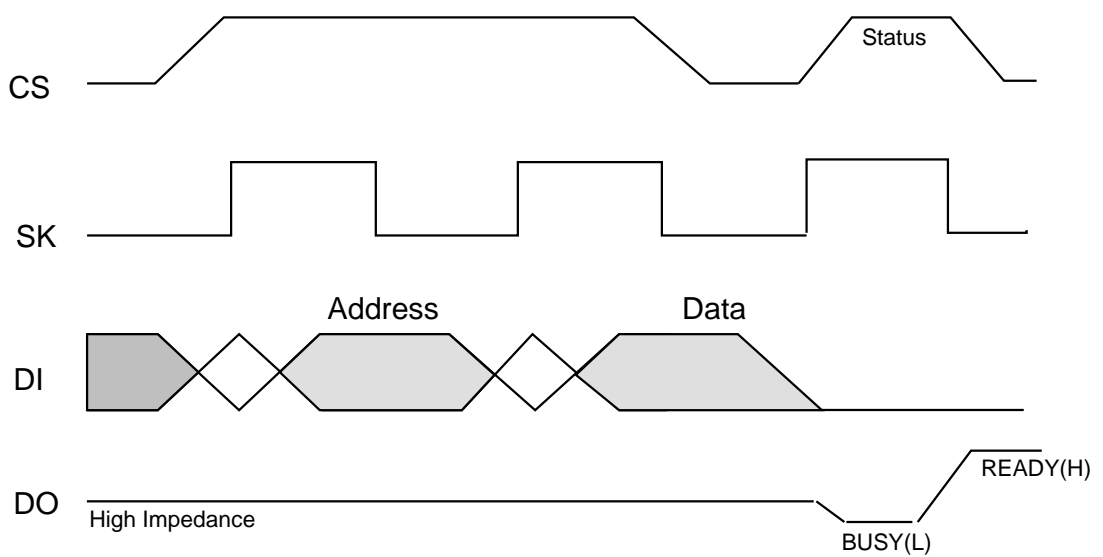

6-4. Printer drive circuit

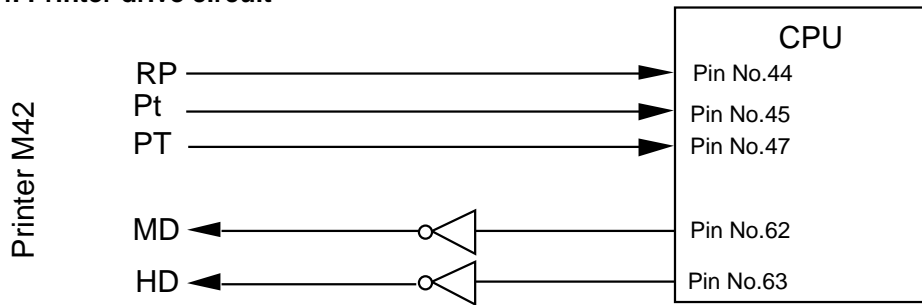

When the CPU start printing, CPU send MD signal to rotate motor unit. Then the printer send back the RP(reset pulse),PT and PT (Timing pulse) to CPU. After CPU receive RP,PT andPT, CPU knows the position of printin wheel. And then, CPU send HD signal to operate the printing magnet when the character selected. The CPU counts the TP signal to select the character.

6-5. Pin description (CPU uPD78042AGF)

Pin No.	Signal	In/Out	Mode SW REG	Mode SW OFF	AC cord Plug off	Description
1	P94/FIP6	Out	Pulse	-24V	L	Display digit signal DG7
2	P93/FIP5	Out	Pulse	-24V	L	Display digit signal DG6
3	P92/FIP4	Out	Pulse	-24V	L	Display digit signal DG5
4	P91/FIP3	Out	Pulse	-24V	L	Display digit signal DG4
5	P90/FIP2	Out	Pulse	-24V	L	Display digit signal DG3
6	P81/FIP1	Out	Pulse	-24V	L	Display digit signal DG2
7	P80/FIP0	Out	Pulse	-24V	L	Display digit signal DG1
8	VDD	-	+5V	+5V	+5V	VDD terminal
9	P27/SCK0	In/Out	-	-	-	Not used
10	P26/SO0/SB1	In/Out	-	-	-	Not used
11	P25/SI0/SB0	In/Out	-	-	-	Not used
12	P24/BUSY	In/Out	-	-	-	Not used
13	P23/STB	Out	H	H	H	Strobe signal for AVREF
14	P22/SCK1	Out	L	H	H	SK signal for EEPROM
15	P21/SO1	Out	L	H	H	DI signal for EEPROM
16	P20/SI1	In	H	H	H	DO signal for EEPROM
17	RESET	In	H	H	H	Reset signal
18	P74	Out	H	H	L	Drawer open signal
19	P73	Out	L	H	H	Common signal for PAD condition
20	AVSS	-	GND	GND	GND	GND for AD converter
21	P17/ANI7	In	GND	GND	GND	GND
22	P16/ANI6	In	GND	GND	GND	GND
23	P15/ANI5	Out	L	L	H	Chip enable signal for EEPROM
24	P14/ANI4	In	GND	GND	GND	GND
25	P13/ANI3	In	GND	GND	GND	GND
26	P12/ANI2	In	GND	GND	GND	GND
27	P11/ANI1	In	GND	GND	GND	GND
28	P10/ANI0	In	H	H	H	Low battery detection terminal
29	AVDD	-	H	H	H	Power for AD converter
30	AVREF	In	L	L	L	Voltage for AD converter (VDD)
31	XT1	In	Pulse	Pulse	Pulse	Sub system clock
32	XT2	-	Pulse	Pulse	Pulse	Sub system clock
33	VSS	-	GND	GND	GND	GND
34	X1	In	Pulse	L	L	Main system clock
35	X2	-	Pulse	H	H	Main system clock
36	P37	In	L	L	L	Mode switch position (OFF)
37	P36/BUZ	Out	L	L	L	Buzzer signal
38	P35/PCL	In	L	L	L	Mode switch position (Z)
39	P34/T12	In	L	L	L	Mode switch position (X)
40	P33/T11	In	L	L	L	Mode switch position (CAL)

Pin No.	Signal	In/Out	Mode SW REG	Mode SW OFF	AC cord Plug off	Description
41	P32/TO2	In	H	L	L	Mode switch position (REG)
42	P31/TO1	In	L	L	L	Mode switch position (RF)
43	P30/TO0	In	L	L	L	Mode switch position (PRG)
44	P03/INTP3/CI0	In	H	L	L	Reset pulse RP from printer
45	P02/INTP2	In	H	Pulse	L	Sub timing pulse Pt from printer
46	P01/INTP1	In	L	L	H	Power down signal PWD
47	P00/INTP0/TI0	In	H	L	L	Main timing pulse PT from printer
48	IC	-	GND	GND	GND	GND
49	P72	In	H	H	H	TAX PAD signal for Japan
50	P71	In	-	-	-	PAD2 condition
51	P70	In	L	H	H	PAD1 condition
52	VDD	-	+5V	+5V	+5V	Power (+5V)
53	P127/FIP33	In	L	L	L	Key input signal KI7
54	P126/FIP32	In	L	L	L	Key input signal KI6
55	P125/FIP31	In	L	L	L	Key input signal KI5
56	P124/FIP30	In	L	L	L	Key input signal KI4
57	P123/FIP29	In	L	L	L	Key input signal KI3
58	P122/FIP28	In	L	L	L	Key input signal KI2
59	P121/FIP27	In	L	L	L	Key input signal KI1
60	P120/FIP26	In	L	L	L	Key input signal KI0
61	P117/FIP25	Out	L	L	L	Winder motor drive signal WMO
62	P116/FIP24	Out	L	L	L	Printer moter drive signal PMO
63	P115/FIP23	Out	L	L	L	Head drive signal for printer PHD
64	P114/FIP22	Out	Pulse	L	L	Key common signal KC3
65	P113/FIP21	Out	Pulse	L	L	Key common signal KC2
66	P112/FIP20	Out	Pulse	L	L	Key common signal KC1
67	P111/FIP19	Out	Pulse	L	L	Key common signal KC0
68	P110/FIP18	Out	H	H	H	Not used (+5V)
69	P107/FIP17	Out	Pulse	-24V	L	Display segment signal Sdp (Decimal point)
70	P106/FIP16	Out	Pulse	-24V	L	Display segment signal Sg
71	VLOAD	-	-24V	-24V	L	Display voltage VN
72	P105/FIP15	Out	Pulse	-24V	L	Display segment signal Sf
73	P104/FIP14	Out	Pulse	-24V	L	Display segment signal Se
74	P103/FIP13	Out	Pulse	-24V	L	Display segment signal Sd
75	P102/FIP12	Out	Pulse	-24V	L	Display segment signal Sc
76	P101/FIP11	Out	Pulse	-24V	L	Display segment signal Sb
77	P100/FIP10	Out	Pulse	-24V	L	Display segment signal Sa
78	P97/FIP9	Out	H	Pulse	L	Mode switch common signal
79	P96/FIP8	Out	Pulse	-24V	L	Display digit signal DG9
80	P95/FIP7	Out	Pulse	-24V	L	Display digit signal DG8

Note : Above data is measured under following condition.

Mode SW REG : AC cord plug in the AC outlet, Memory protection batteries in,
Mode SW position : REG

Mode SW OFF : AC cord plug in the AC outlet, Memory protection batteries in,
Mode SW position : OFF

AC cord plug off : AC cord plug out the AC outlet, memory protection batteries in,
Mode SW position : OFF

7. DISASSEMBLY

7-1. To open the upper case

1. Take out the printer cover and release the screw A.
2. Pushing the position B and slide the upper case to backward.
3. Lift up the upper case and remove the drawer connector.

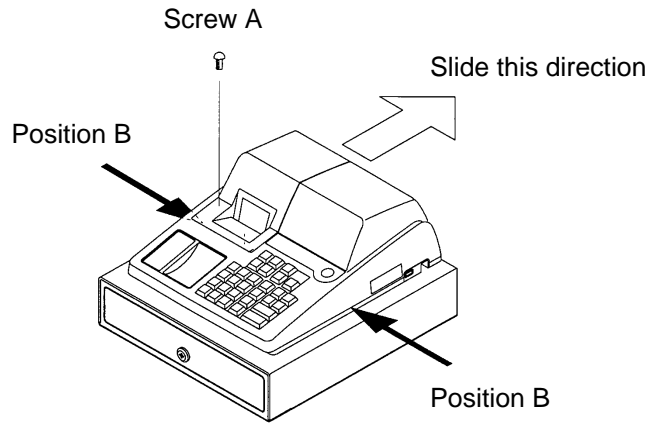

7-2. To remove the Main PCB

1. Remove all cables on Main PCB and release 3 pcs of screw B.
2. Take out the Main PCB ass'y.

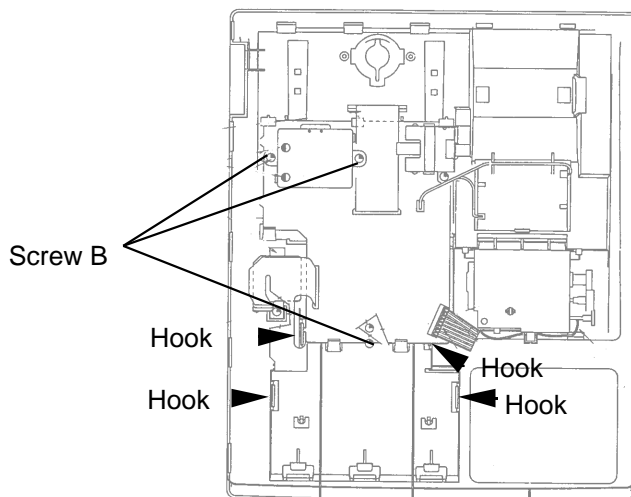

7-3. To remove the keyboard ass'y

1. Release the 4 hooks and push the keyboard ass'y down.

8. DIAGNOSTIC OPERATIONS

8-1. To start the diagnostic operation

1. Make MAC operation.
2. Turn the mode switch to PGM position.
3. Input "99999999" and press "SUB TOTAL" key.

Note : Do not issue the receipt under REG / RF / X / Z mode before execute the diagnostic.
If the machine issued a receipt, the diagnostic does not start.

Print ing Layout

```
00-00-00
00-00#0002
-d1d2d3d4--d5d6d7
```

Receipt sample

```
00-00-00
00-00#0002
-2862--1--
```

d1d2d3d4 : Version No.

d5 : PAD condition
0 : Japan
1 : Export (ADD2)
2 : US / Canada
3 : Export (ADD3)
4 : Export (ADD1)

d6 :
0 : Non taxable (Japan)
1 : Taxable (Japan)
- : Export version

d7:
0 : 118ER (Japan)
1 : 108ER (Japan)
- : Export version

8-2. Check items

The following test can be checked in the test mode.

1. Key code check
2. Switch check
3. Individual function check
4. Country code write operation for EEPROM (PAD data)

8-3. Operations

1. Key code check (Hard key code)

When pressing a key, the machine displays the following key code.

Key code table

FEED	029	027	021
C	028	026	020

7	8	9	025	019	017
4	5	6	024	018	016
1	2	3	023	014	015
0	011	012	022	013	127

Display

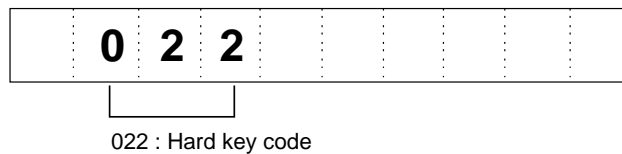

2. Switch check

Press " C " button, the switch condition is appeared on a display.

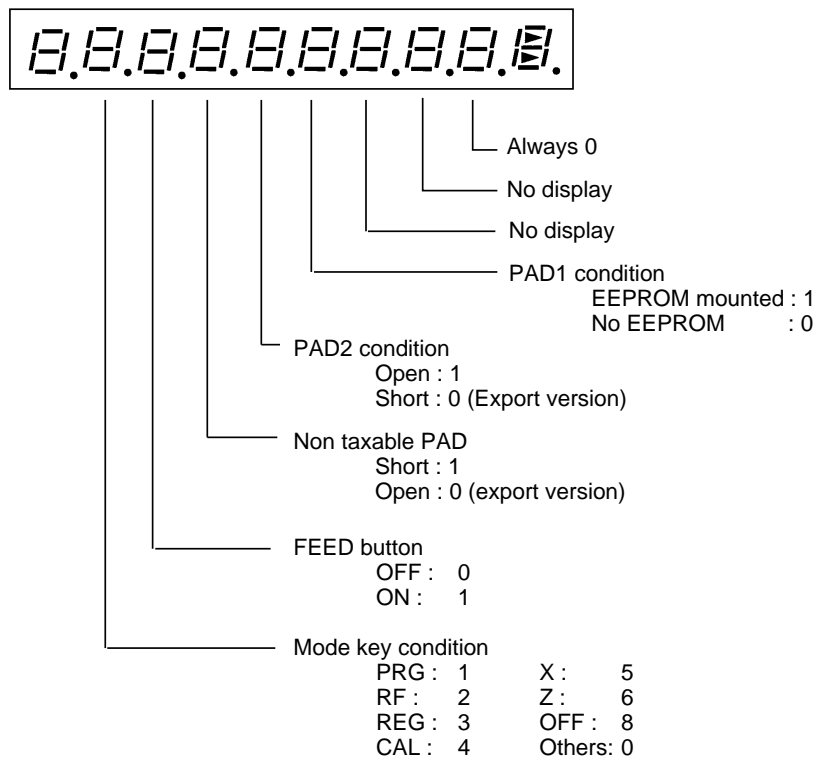

3. Individual test

After finishing each test, the machine issues the following receipt.

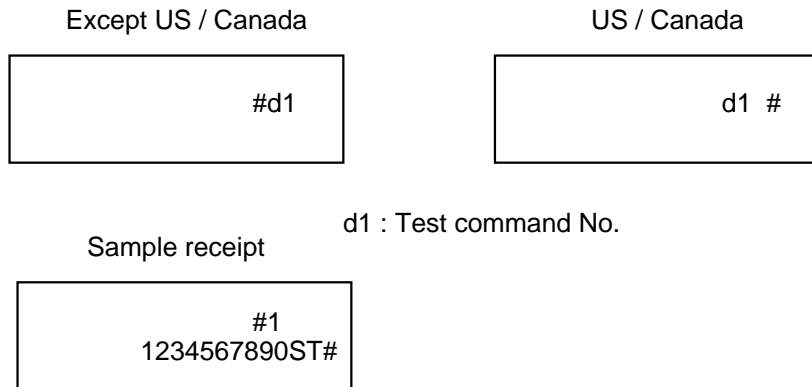

1. General test

Press "1" key and "SUB TOTAL" key.

The machine executes the following tests.

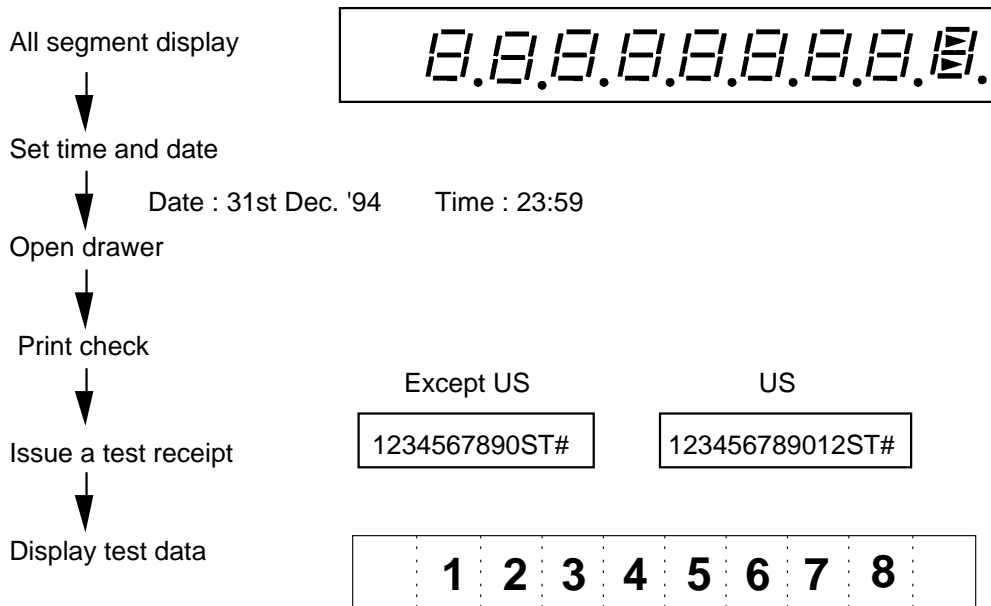

2. Mode selection (Receipt / Journal)

Press "2" key and "SUB TOTAL" key.

Change the mode to "Journal" from "Receipt".

3. Read/Write test for EEPROM (This test is effected at EEPROM version.)

Press "3" key and "SUB TOTAL" key.

Write a test data (1 word) to test area of EEPROM and read it.

In case an error happens, the machine beep an error sound and issues an error receipt.

4. Read only test for EEPROM (This test is effected at EEPROM version.)

Press "4" key and "SUB TOTAL" key.

Execute read check in test area of EEPROM continually.

To escape this test, turn the mode switch to "OFF".

In case an error happens, the machine beep an error sound and issues an error receipt.

Nomal end receipt	Error end receipt		
Excepty US	Except US		
<table border="1" style="width: 100%; border-collapse: collapse;"> <tr> <td style="text-align: center;">1 2 3 4 5 6 7 8 9 0 ST #</td> </tr> </table>	1 2 3 4 5 6 7 8 9 0 ST #	<table border="1" style="width: 100%; border-collapse: collapse;"> <tr> <td style="text-align: center;"># # # # # # # # 8</td> </tr> </table>	# # # # # # # # 8
1 2 3 4 5 6 7 8 9 0 ST #			
# # # # # # # # 8			
US	US		
<table border="1" style="width: 100%; border-collapse: collapse;"> <tr> <td style="text-align: center;">1 2 3 4 5 6 7 8 9 0 1 2 ST #</td> </tr> </table>	1 2 3 4 5 6 7 8 9 0 1 2 ST #	<table border="1" style="width: 100%; border-collapse: collapse;"> <tr> <td style="text-align: center;">. 8</td> </tr> </table> 8
1 2 3 4 5 6 7 8 9 0 1 2 ST #			
. 8			

5. Battery voltage check

Press "7" key and "SUB TOTAL" key.

Display the voltage level of memroy protection battery.

To escape this test, turn the mode switch to "OFF".

VCC=5.35V(Standard)

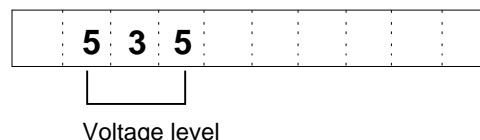

6. Print test

Press "8" key and "SUB TOTAL" key.

The machine prints all chatacter.

Receipt sample

```

# 8
0 0 0 0 0 0 0 0 0 0 CA Z
1 1 1 1 1 1 1 1 1 1 CH 1
2 2 2 2 2 2 2 2 2 2 RA 2
3 3 3 3 3 3 3 3 3 3 PO 3
4 4 4 4 4 4 4 4 4 4 NT 4
5 5 5 5 5 5 5 5 5 5 STCK
6 6 6 6 6 6 6 6 6 6 AT +
7 7 7 7 7 7 7 7 7 7 CG -
8 8 8 8 8 8 8 8 8 8 TX X
9 9 9 9 9 9 9 9 9 9 RF@
- - - - -
. . . . . * #
. . . . . •%NS
# # # # # # # # # VDTA
    
```

Note : US version is printed out 14 characters.

7. Time test

Press "9" key and "SUB TOTAL" key.

Display the time.

To escape this test, press "C" key.

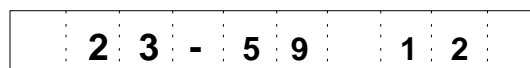

8. Country code write operation for EEPROM (ADD data)

Press "X", "6" and "SUB TOTAL" keys.
Write the country code to EEPROM.

Note 1 : "X" key is country code.

- 0 : Japan
- 1 : Export (ADD2)
- 2 : US / Canada
- 3 : Export (ADD3)
- 6 : Export (ADD1)
- 9 : Dammy code
(Delete a country code.)

Note 2 : Japan version is accepted code "06"
and "96".

Export version is not accepted code "06".
In case the machine receive wrong code,
the machine is issued an error receipt.

In case an error happens, the machine beep an error sound and issues an error receipt.

Note 3 : When PAD1 is open, this test is not excuted. Just print a function code on the receipt.

Print ing Layout

```

0 1 - 0 1 - 9 5
0 0 - 0 1 # 0 0 0 5
- d1d2d3d4 - - d5d6d7
    
```

Receipt sample

```

# 1 6
0 1 - 0 1 - 9 5
0 0 - 0 1 # 0 0 0 2
- 2 8 6 2 - - 1 - -
    
```

d1d2d3d4 : Version No.

d5 : PAD condition

- 0 : Japan
- 1 : Export (ADD2)
- 2 : US / Canada
- 3 : Export (ADD3)
- 4 : Export (ADD1)

d6 :

- 0 : Non taxable (Japan)
- 1 : Taxable (Japan)
- : Export version

d7:

- 0 : 118ER (Japan)
- 1 : 108ER (Japan)
- : Export version

Error receipt sample

Ecxept US

8

US

. 8

4. To escape the diagnostic operation

Exexute the MAC operation (Memory All Clear).

Note : Make sure to remove the memory protection batteries.

9. IC DATA

9-1. LB1268

Equivalent circuit

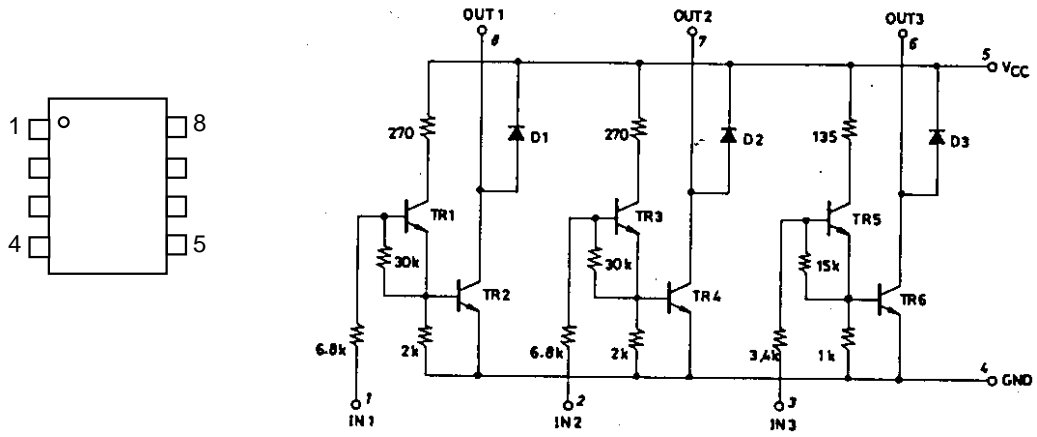

9-2. S-80728AN-Z

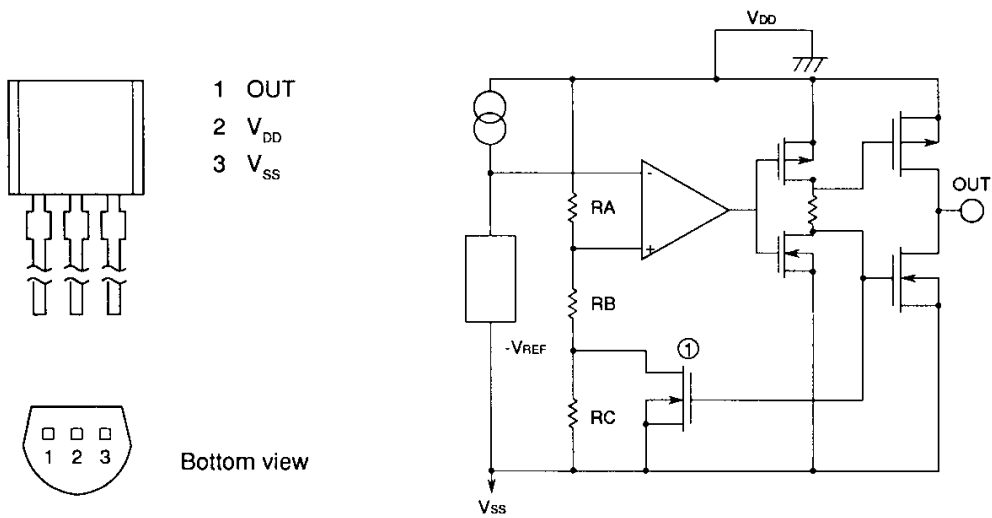

10. CIRCUIT DIAGRAM

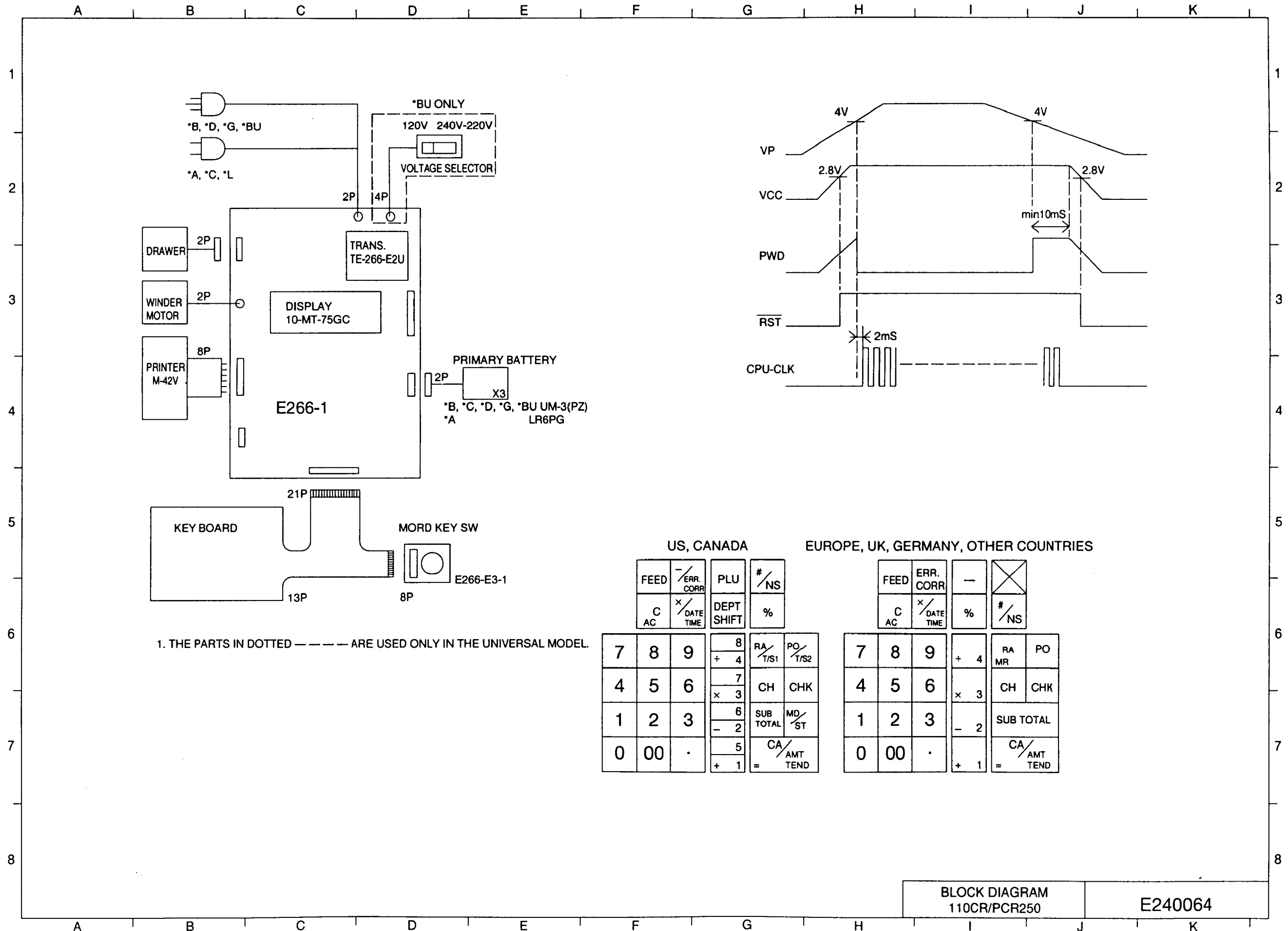

1. THE PARTS IN DOTTED — — — ARE USED ONLY IN THE UNIVERSAL MODEL.

US, CANADA				EUROPE, UK, GERMANY, OTHER COUNTRIES			
FEED	ERR. CORR.	PLU	#/NS	FEED	ERR. CORR.	-	X
C AC	X/DATE TIME	DEPT SHIFT	%	C AC	X/DATE TIME	%	#/NS
7	8	9	8	7	8	9	8
4	5	6	RA/T/S1	4	5	6	RA MR
1	2	3	PO/T/S2	1	2	3	PO
0	00	.	CH	0	00	.	CH
			CHK				CHK
			SUB TOTAL				SUB TOTAL
			CA/AMT TEND				CA/AMT TEND

BLOCK DIAGRAM 110CR/PCR250 E240064

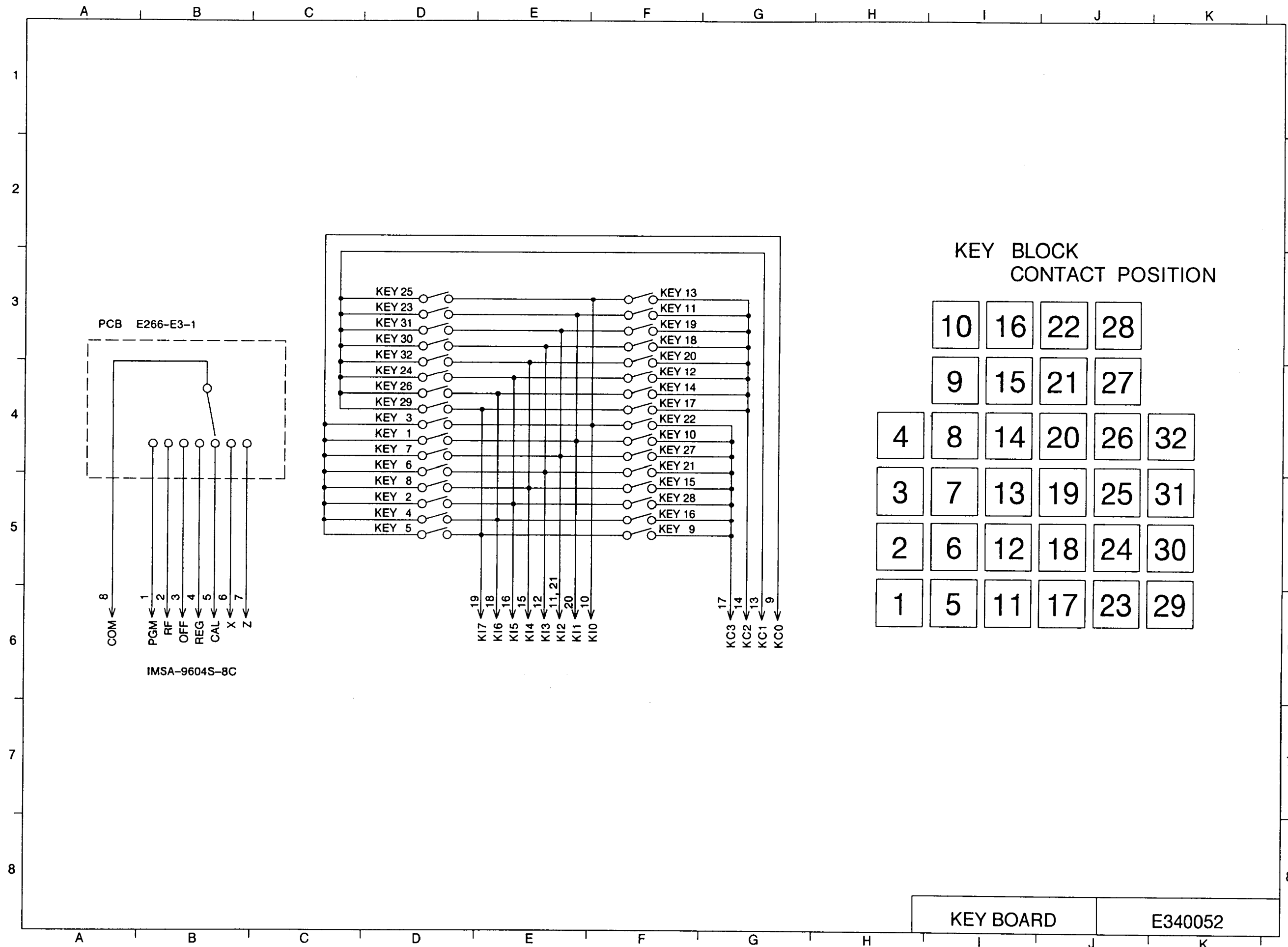

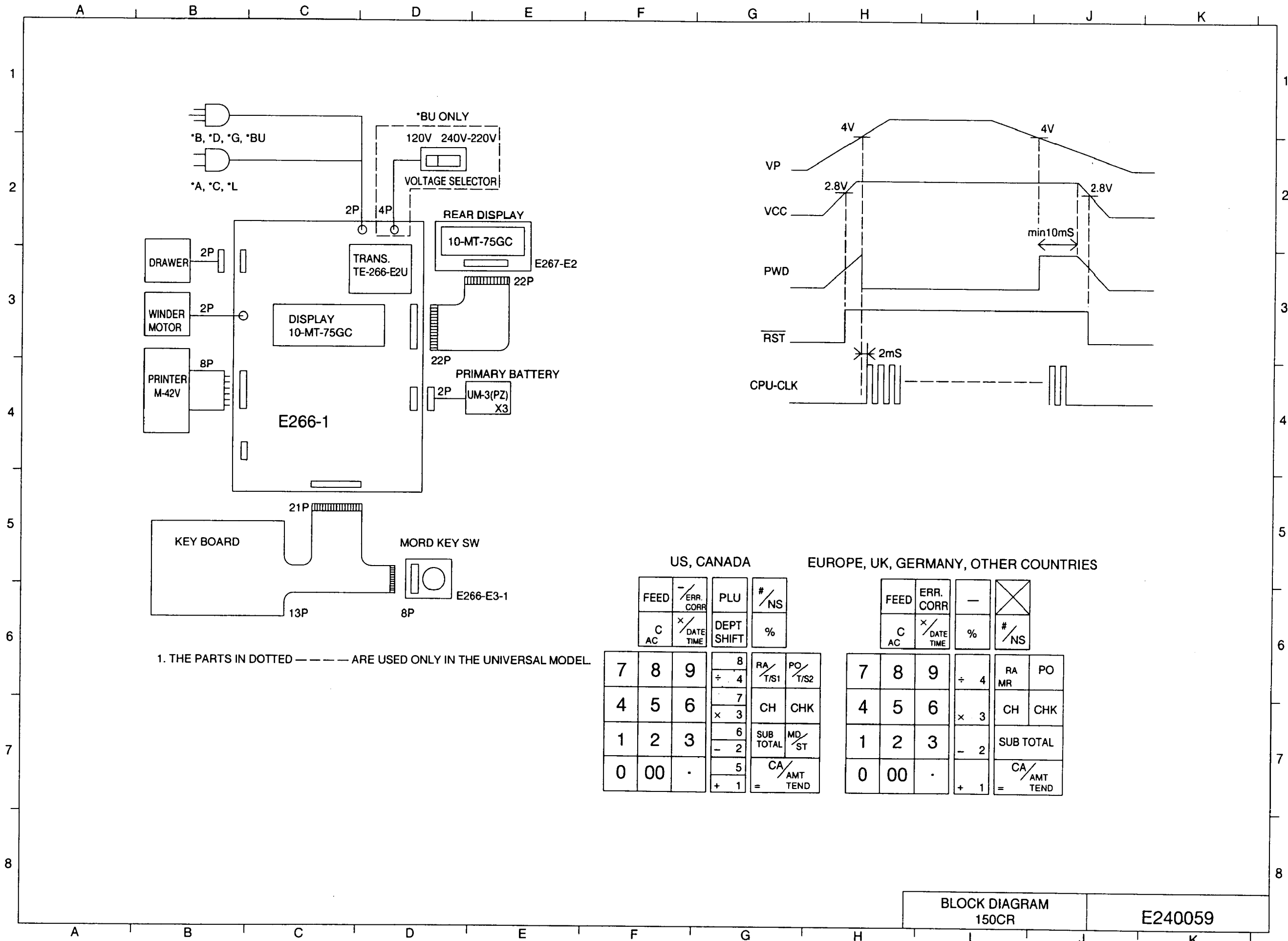

1. THE PARTS IN DOTTED ----- ARE USED ONLY IN THE UNIVERSAL MODEL.

US, CANADA

FEED	ERR. CORR.	PLU	#/NS
C AC	x/DATE TIME	DEPT SHIFT	%
7	8	9	RA/PO
4	5	6	CH/CHK
1	2	3	SUB TOTAL/MD/ST
0	00	.	CA/AMT TEND

EUROPE, UK, GERMANY, OTHER COUNTRIES

FEED	ERR. CORR.	-	X
C AC	x/DATE TIME	%	#/NS
7	8	9	RA/PO
4	5	6	CH/CHK
1	2	3	SUB TOTAL
0	00	.	CA/AMT TEND

BLOCK DIAGRAM
150CR

E240059

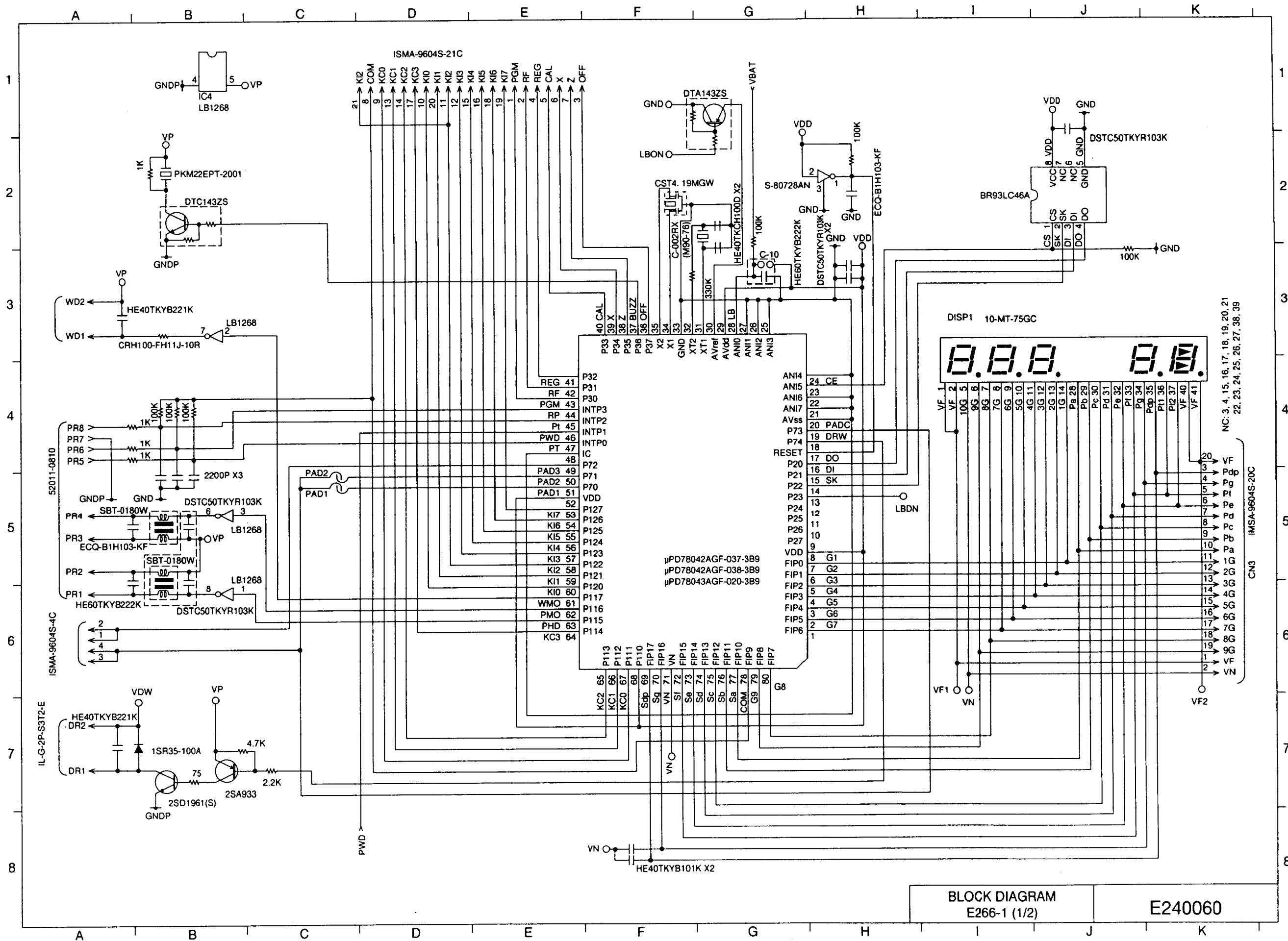

BLOCK DIAGRAM
E266-1 (1/2)

E240060

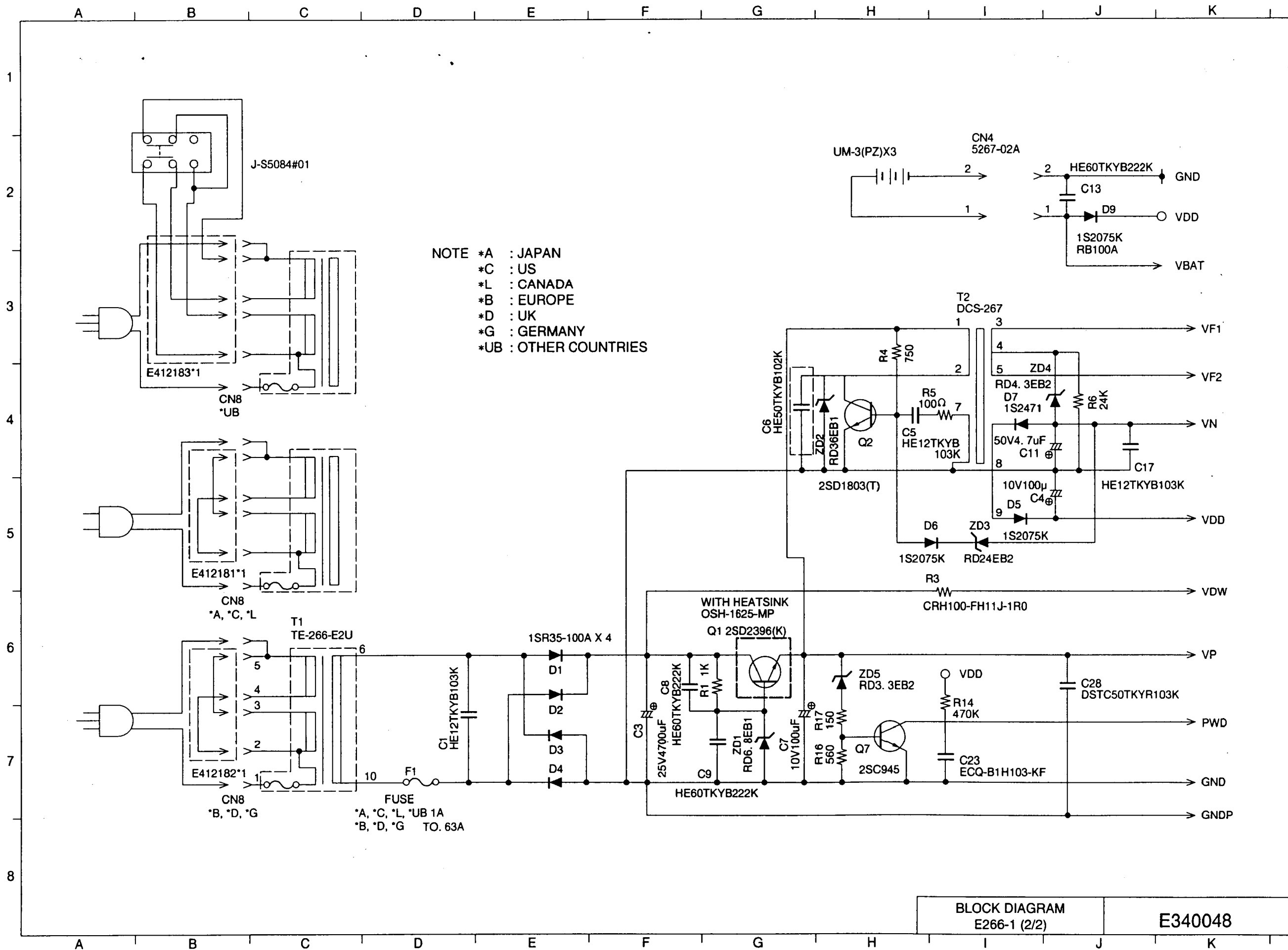

NOTE *A : JAPAN
 *C : US
 *L : CANADA
 *B : EUROPE
 *D : UK
 *G : GERMANY
 *UB : OTHER COUNTRIES

BLOCK DIAGRAM
 E266-1 (2/2)
 E340048

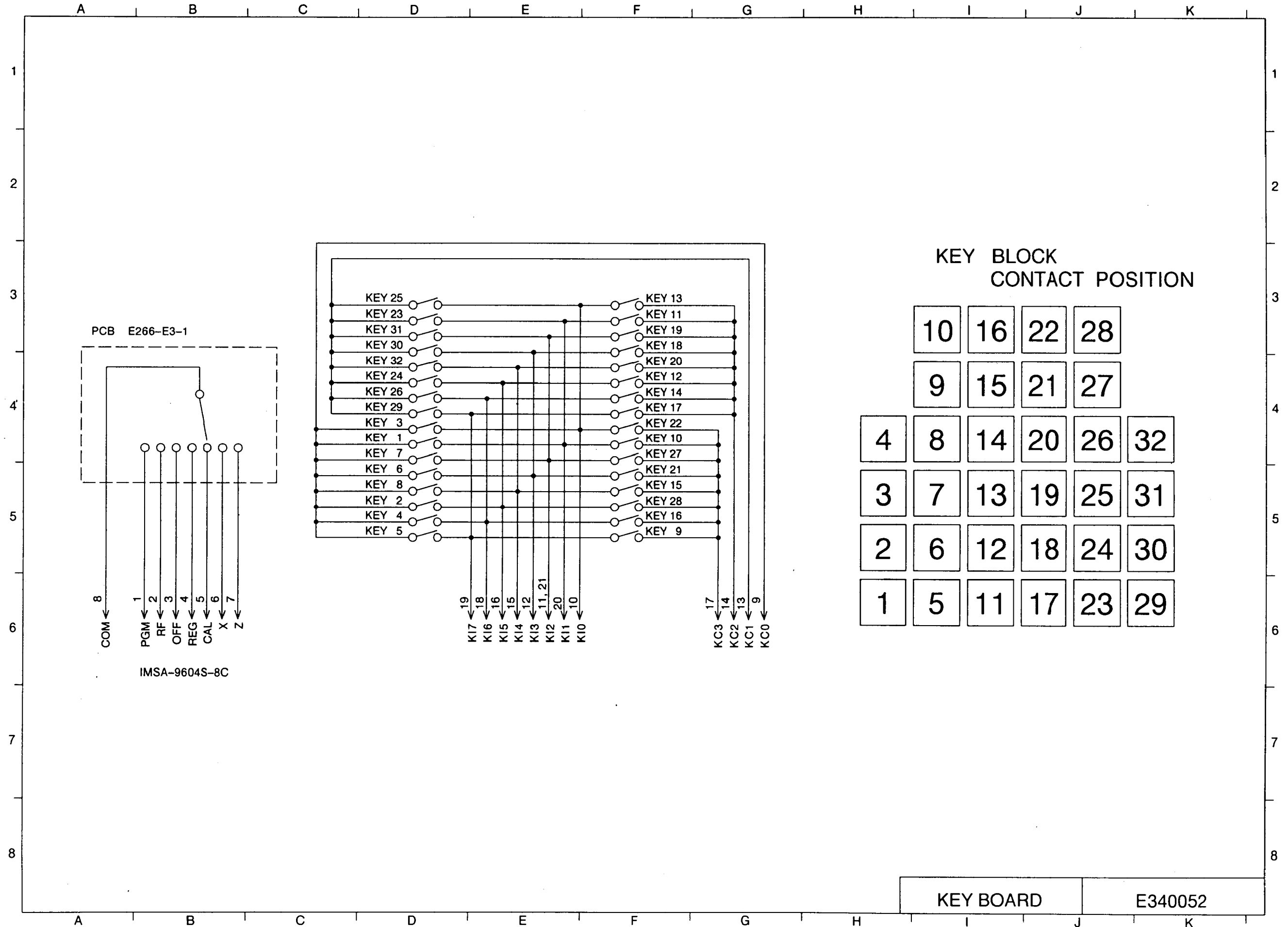

PCB E266-E3-1

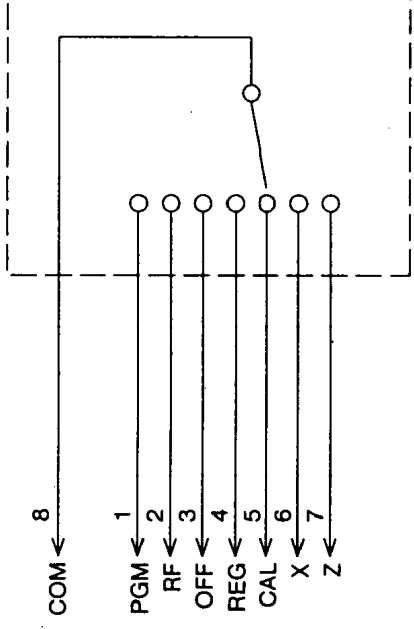

IMSA-9604S-8C

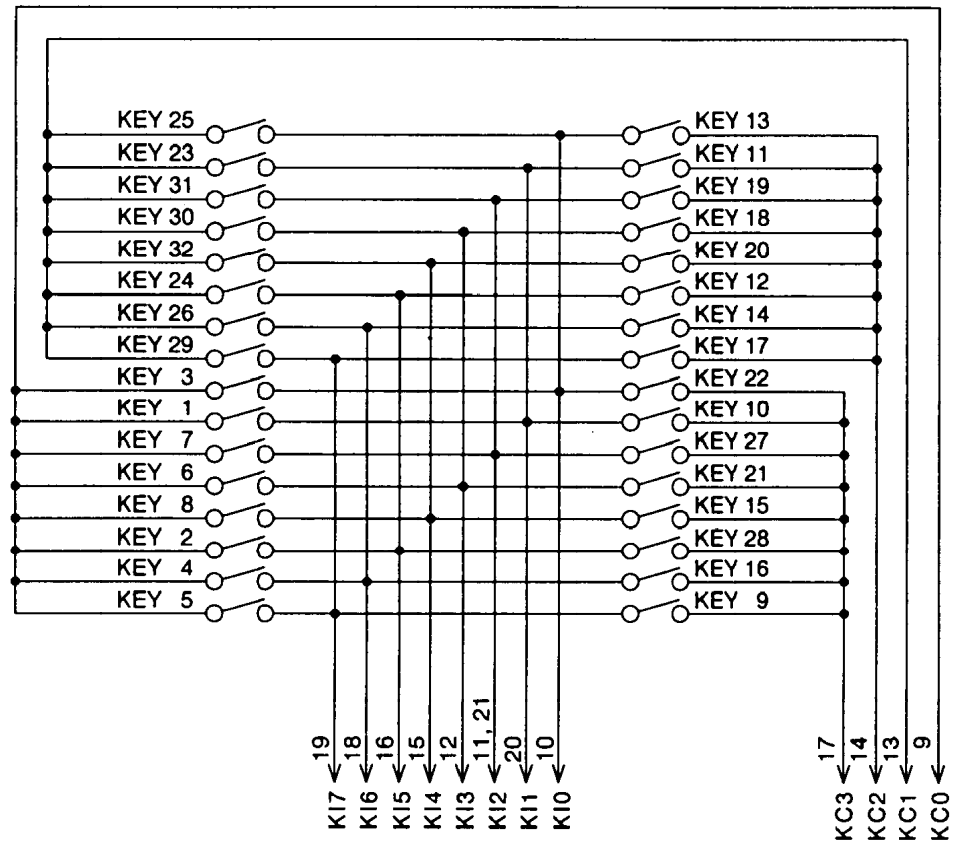

KEY BLOCK CONTACT POSITION

10	16	22	28		
9	15	21	27		
4	8	14	20	26	32
3	7	13	19	25	31
2	6	12	18	24	30
1	5	11	17	23	29

KEY BOARD E340052

DISP2 10-MT-75GC

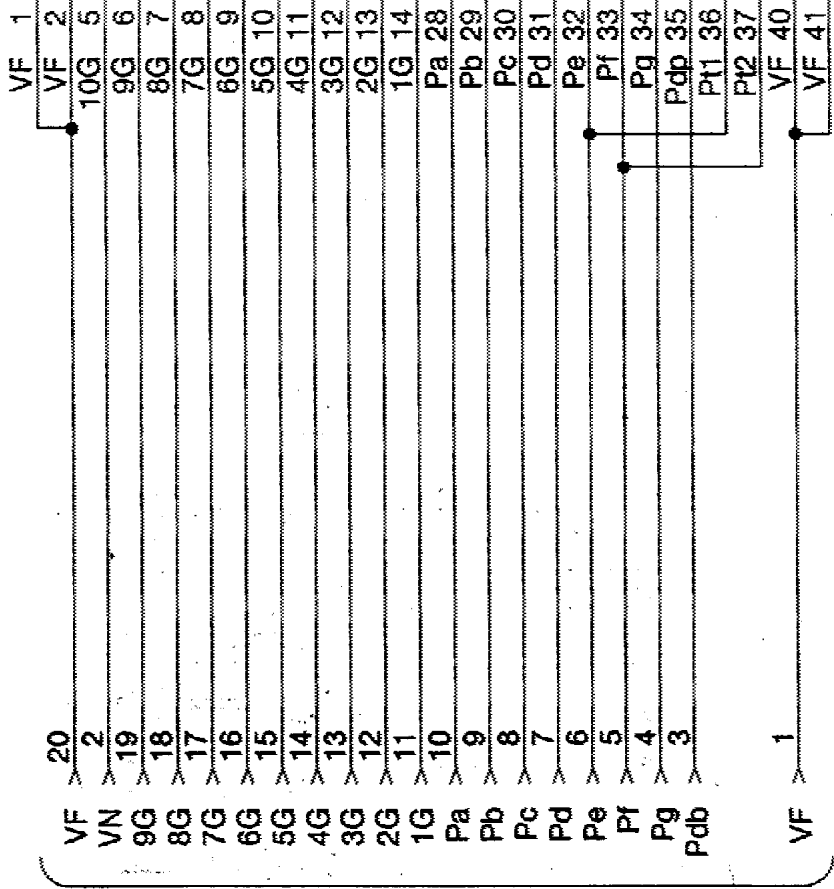

E267-E2 CON.1 IMSA-9604S-20C

NC: 3, 4, 15, 16, 17, 18, 19, 20, 21
22, 23, 24, 25, 26, 27, 38, 39

2ND DISPLAY
150CR

E440054

12. PARTS LIST

1. MAIN PCB BLOCK
2. 2ND DISPLAY BLOCK (150CR ONLY)
3. POWER SUPPLY BLOCK
4. KEYBOARD BLOCK
5. UPPER CASE BLOCK
6. OTHERS
7. PRINTER UNIT
8. DRAWER
 - DL-1313
 - DL-1817
 - DL-2749
 - DL-2349

Notes:

1. Price and specifications are subject to change without notice.
2. As for order / supply of spare parts, refer to the "GUIDE BOOK for spare parts supply" a separate publication.
3. Numbers in the item column correspond to the same numbers in exploded drawing.
4. MARKS:

N: New parts

Q: Quantity used per unit

M: Minimum order/supply quantity

R: Rank

A: Essential

B: Stock recommended

C: Less recommended

X: No stock recommended

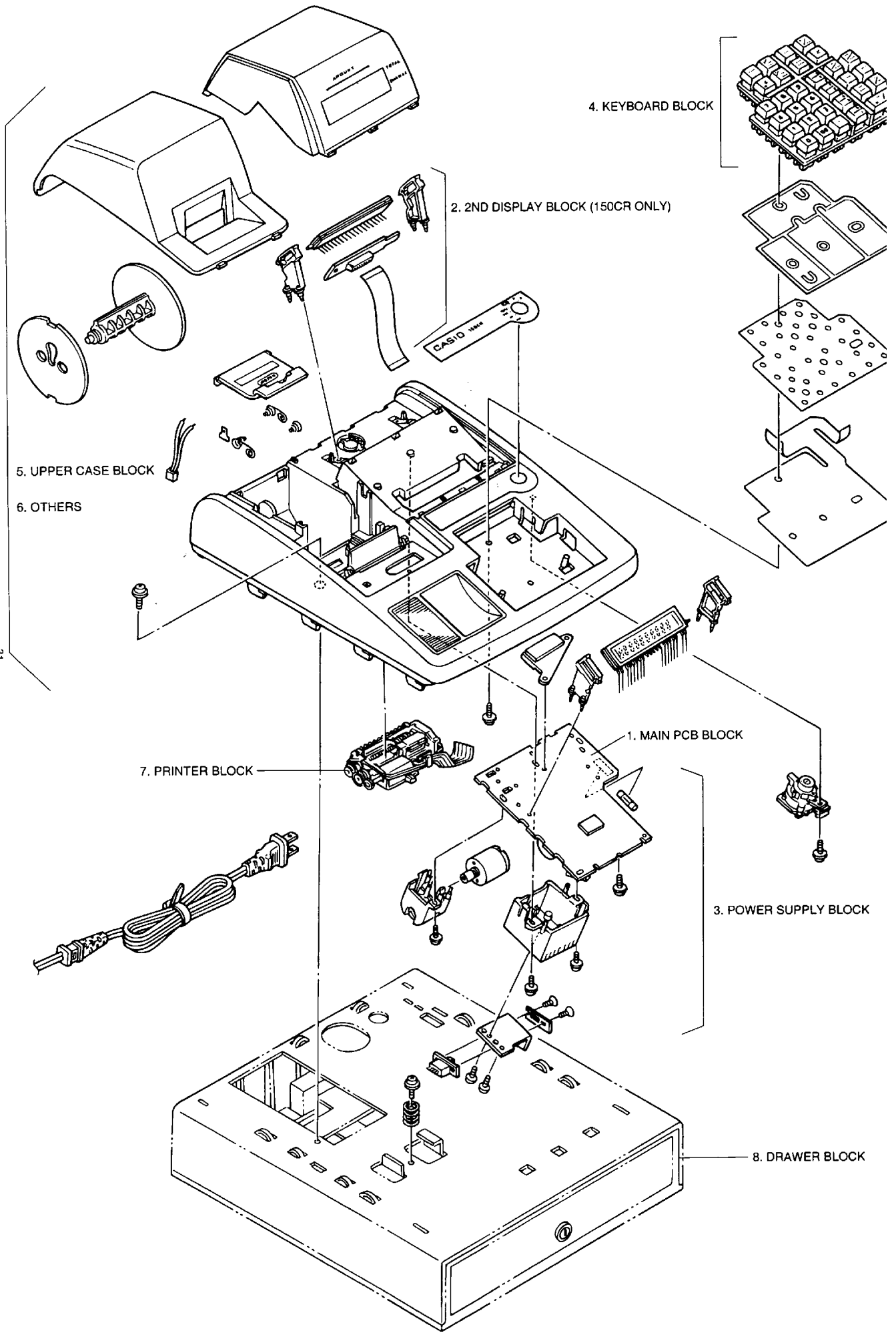

1.MAIN PCB BLOCK

N	Item	Code No.	Parts Name	Specification	Version	M	Q	FOB Japan N.R.Yen Unit Price	R
			MAIN PCB ASS'Y						
N		6192 4860	Main PCB E266-1ass'y (110CR)	E211682*2	U.S.A.,Canada		1		A
N		6192 4870	Main PCB E266-1ass'y (110CR)	E211682*3	Europe		1		A
N		6192 4880	Main PCB E266-1ass'y (110CR)	E211682*4	U.K.		1		A
N		6192 4890	Main PCB E266-1ass'y (110CR)	E211682*5	Germany		1		A
N		6192 4900	Main PCB E266-1ass'y (110CR)	E211682*6	Other countries		1		A
N		6192 5230	Main PCB E267-1 ass'y (150CR)	E211683*1	U.S.A.,Canada		1		A
N		6192 5240	Main PCB E267-1 ass'y (150CR)	E211683*2	Europe		1		A
N		6192 5250	Main PCB E267-1 ass'y (150CR)	E211683*3	U.K.		1		A
N		6192 5260	Main PCB E267-1 ass'y (150CR)	E211683*4	Germany		1		A
N		6192 5270	Main PCB E267-1 ass'y (150CR)	E211683*5	Othercountries		1		A
N	IC1	2006 0941	EEPROM	BR93LC46A	Except U.S.A.,Canada		1	130	A
	IC4	2120 6253	Monolithic IC	LB1268			1	90	A
	IC2	2120 7393	Reset IC	S-80728AN-Z		10	1	47	A
N	IC3	2006 1060	LSI	UPD78042AGF038-3B9	U.S.A., Canada		1	650	A
N	IC3	2006 1179	LSI	UPD78042AGF045-3B9	Except U.S.A.,Canada		1	650	A
	Q4	2200 9141	Transistor	2SA933(K,P,Q,R)		10	1	14	B
	Q7	2220 2456	Transistor	2SC945(K,P,Q,R)			1	20	B
N	Q2	2250 1022	Transistor	2SD1803(T)			5	60	B
N	Q3	2250 1029	Transistor	2SD1961(S)		10	1	30	B
N	Q1	2250 1036	Transistor	2SD2396(K)			5	50	B
	Q6	2250 0847	Digital transistor	DTC143ZS		10	1	10	B
N	D5,6,9	2315 2689	Diode	1S2075K		20	3	4	B
	D7	2301 0046	Diode	1S2471			1	4	B
N	D1,2,3,4,8	2315 2682	Diode	1SR35-100A		20	5	10	B
	D9	2390 1323	Diode	RB100A			1	29	B
N	ZD3	2315 2766	Zener diode	RD24EB2		20	1	8	B
N	ZD5	2315 2654	Zener diode	RD3.3EB2		20	1	8	B
N	ZD2	2315 2661	Zener diode	RD36EB1		20	1	8	B
N	ZD4	2315 2759	Zener diode	RD4.3EB2		20	1	8	B
N	ZD1	2315 2675	Zener diode	RD6.8EB1		20	1	8	B
N	R10,11,12, 18,19,20	2652 1266	Carbon film resistor	CR-25-100KOHMJ		10	6	25	C
N	R5	2652 1140	Carbon film resistor	CR-25-100OHMJ		10	1	25	C
N	R17	2652 1147	Carbon film resistor	CR-25-150OHMJ		10	1	25	C
N	R1,15,21, R22,23	2652 1168	Carbon film resistor	CR-25-1KOHMJ		10	5	25	C
N	R8	2601 6843	Carbon film resistor	CR-25-2.2KOHMJ		10	1	25	C
N	R6	2652 2092	Carbon film resistor	CR-25-24KOHM-J		10	1	25	C
N	R13	2652 1273	Carbon film resistor	CR-25-330KOHMJ		10	1	25	C
N	R9	2652 1210	Carbon film resistor	CR-25-4.7KOHMJ		10	1	25	C
N	R14	2652 1434	Carbon film resistor	CR-25-470KOHM-J		10	1	25	C
N	R16	2652 1154	Carbon film resistor	CR-25-560OHMJ		10	1	25	C
N	R4	2652 2085	Carbon film resistor	CR-25-750OHM-J		10	1	25	C
N	R7	2652 2015	Carbon film resistor	CR-25-75OHM-J		20	1	2	C
N	R13	2652 2127	Carbon film resistor	R-25-1.5M-J-T34V		10	1	25	C
	R2	2700 7821	Metal film resistor	CRH100-FH11J-10R			1	7	C
	R3	2775 1225	Metal film resistor	CRH100-FH11J-1R0			1	7	C

N	Item	Code No.	Parts Name	Specification	Version	M	Q	FOB Japan N.R.Yen Unit Price	R
	C11	2807 2735	Electrolytic capacitor	RE2-50V4R7M		10	1	20	C
N	C4,7	2807 2315	Electrolytic capacitor	RE3-10V101M		20	2	12	C
	C3	2807 2658	Electrolytic capacitor	RE3-25V472M		20	1	8	C
N	C20,23,31	2820 3778	TF capacitor	ECQ-B1H-103KF		20	3	7	C
	C2,16,19,28	2825 0427	TF capacitor	RT-DSTC50TKYR103K		20	4	28	C
	C1,3,17	2818 0454	Ceramic capacitor	RT-HE12TKYB103K			3	8	C
	C21,22	2818 3291	Ceramic capacitor	RT-HE40TKCH120J			2	6	C
	C14,15	2818 0446	Ceramic capacitor	RT-HE40TKYB101K			2	4	C
	C10,12	2818 0390	Ceramic capacitor	RT-HE40TKYB221K		20	2	4	C
	C8,9,18,24, C25,26,27	2818 0403	Ceramic capacitor	RT-HE60TKYB222K		10	6	3	C
	CN7	3500 1077	Connector	52011-0810		10	1	28	C
	CN4	3510 3465	PCB connector	5267-02A		10	1	8	C
N	CN1	6246 2780	Connector sub ass'y	E311971*1		5	1	52	X
N	CN8	6246 2830	Conector sub ass'y	E412181*1	U.S.A. ,Canada		1	130	X
N	CN8	6246 2930	Conector sub ass'y	E412182*1	Europe,U.K.,Germany		1	140	X
N	CN8	6246 2940	Conector sub ass'y	E412183*1	Other countries		1	140	X
N	CN3	3540 4780	PCB connector (for 150CR)	IMSA-9604S-20C		5	1	75	C
	CN2	3500 3371	Connector 2P	IL-G-2P-S3T2-E		10	1	5	C
N	CN6	3540 4759	PCB connector	IMSA-9604S-21C		10	1	29	C
N	CN5	3540 4843	PCB connector	IMSA-9604S-4C		20	1	17	C
N	F1	3631 0330	Fuse	237001	U.S.A. ,Canada, Other countries	5	1	52	A
	F1	3000 7245	SEMKO fuse	218.630	Europe,U.K.,Germany	10	1	49	A
	F1	3640 2331	Fuse holder	UF-0033		10	2	3	C
N		6246 5490	Fuse label 1	E440016-1	Europe,U.K.,Germany	10	1	26	X
	X1	2520 3445	Crystall oscillator	C-002RX(M90-76)			1	47	A
	X2	2801 8932	Ceramic oscillator	CST4.19MGW			1	75	A
	L2	3013 0602	Inducter	SBT-0180W	Except U.S.A.,Canada		1	83	C
N	T1	3000 7098	Power transformer	TE-266-E2U			1	730	B
N	T2	3000 7091	DC/DC converter	DCS-267			1	390	A
N	DISP1	2408 8219	Display tube	10-MT-75GC			1	540	B
	BZ1	3240 2089	Sounducer	PKM22EPT-2001			1	100	C
	Q-1	3750 1212	Heat sink	OSH-1625-MP		5	1	70	C
N		4308 1011	PCB E266-1 (without components)	E211689-1			1	180	X

2. 2ND DISPLAY BLOCK (150CR ONLY)

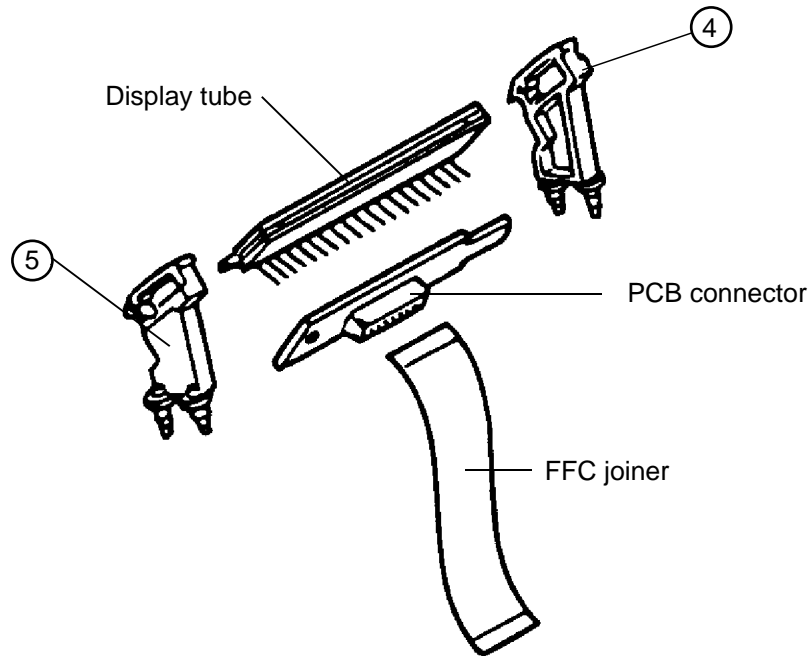

N	Item	Code No.	Parts Name	Specification	Version	M	Q	FOB Japan N.R.Yen Unit Price	R
			E276-E2 ASS'Y (150CR ONLY)						
N		2408 8219	Display tube	10-MT-75GC			1	540	A
N		3540 4780	PCB connector	IMSA-9604S-20C		5	1	75	C
N		6246 2550	FFC joiner E267	E412162-1			1	100	C
N	4	6246 1980	Display fixing stand L	E412090-1		10	1	26	X
N	5	6246 1970	Display fixing stand R	E412089-1		10	1	26	X

3. POWER SUPPLY BLOCK

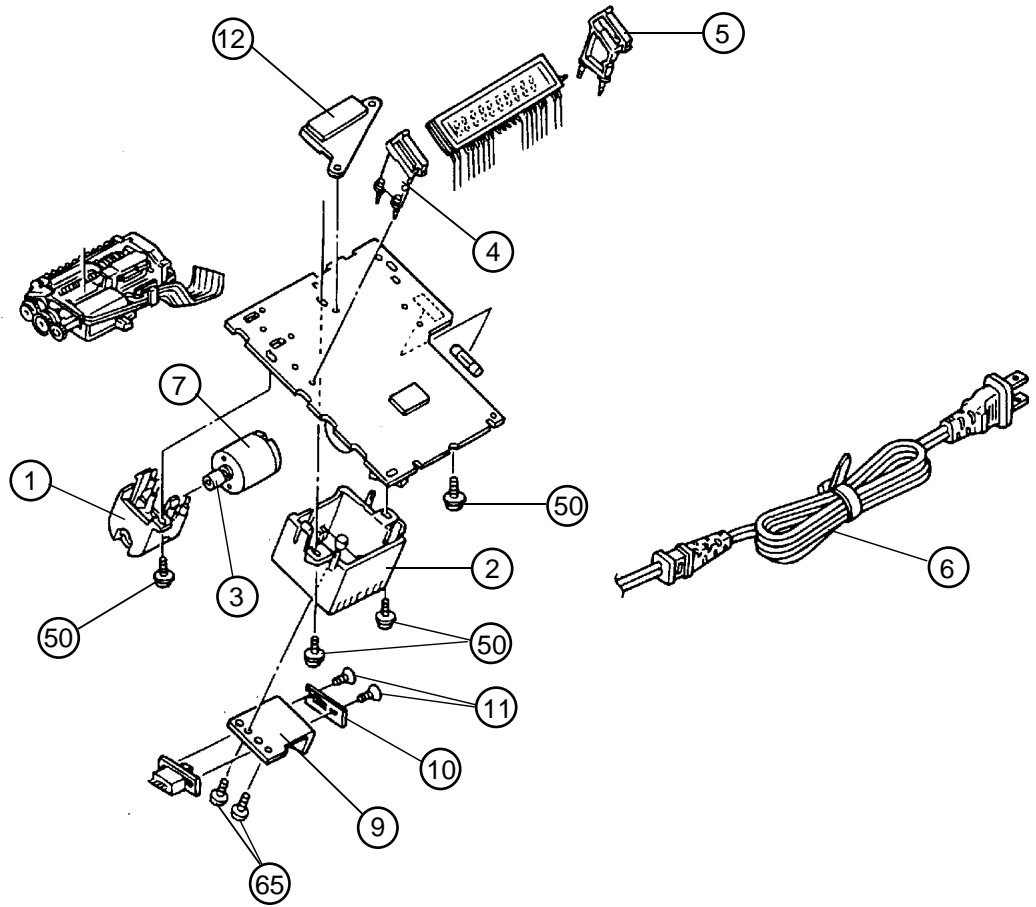

N	Item	Code No.	Parts Name	Specification	Version	M	Q	FOB Japan N.R.Yen Unit Price	R
			POWER SUPPLY BLOCK						
N	1	6246 1820	Motor fixing stand	E311858-1		5	1	79	X
N	2	6246 2850	Transformer cover	E311870-1			1	110	X
	3	6220 1746	Winder rubber	E410716-1		20	1	19	A
N	4	6246 1980	Display fixing stand L	E412090-1		10	1	26	X
N	5	6246 1970	Display fixing stand R	E412089-1		10	1	26	X
	6	3701 0221	Power cord	PS5006-B	U.K.,Other countries		1	730	C
N	6	3701 0228	Power cord	ME301S	U.S.A.,Canada,		1	280	C
	6	6221 4802	Power cord	M2511	Europe,Germany, Other countries		1	400	C
N	6	3700 4283	Power cord	M3203	Australia,Other countirs		1	340	C
	6	3700 4281	Power cord	PS204	Other countries		1	400	C
	7	3200 3672	Motor	MXN-13FB12F			1	270	B
N	8	3000 7105	Voltage selector	J-S5084#01	Other countries		1	300	X
N	9	6246 2860	Voltage selector fixing stand	E412140-1	Other countries	5	1	50	X
N	10	6246 6326	Voltage plate	E440038-1	Other countries	5	1	50	X
	11	5150 1621	Screw (+)	3x8 ZMC-3	Other countries	20	2	5	X
N	12	6246 5500	Insulation plate	E440007-1	Except other countries		1	100	X
	13	5560 0368	Wire band	T-18S	Except other countries	10	1	2	X
N	65	5150 1621	SCREW(+)	3X8 ZMC-3		20	2	3	X

4. KEYBOARD BLOCK

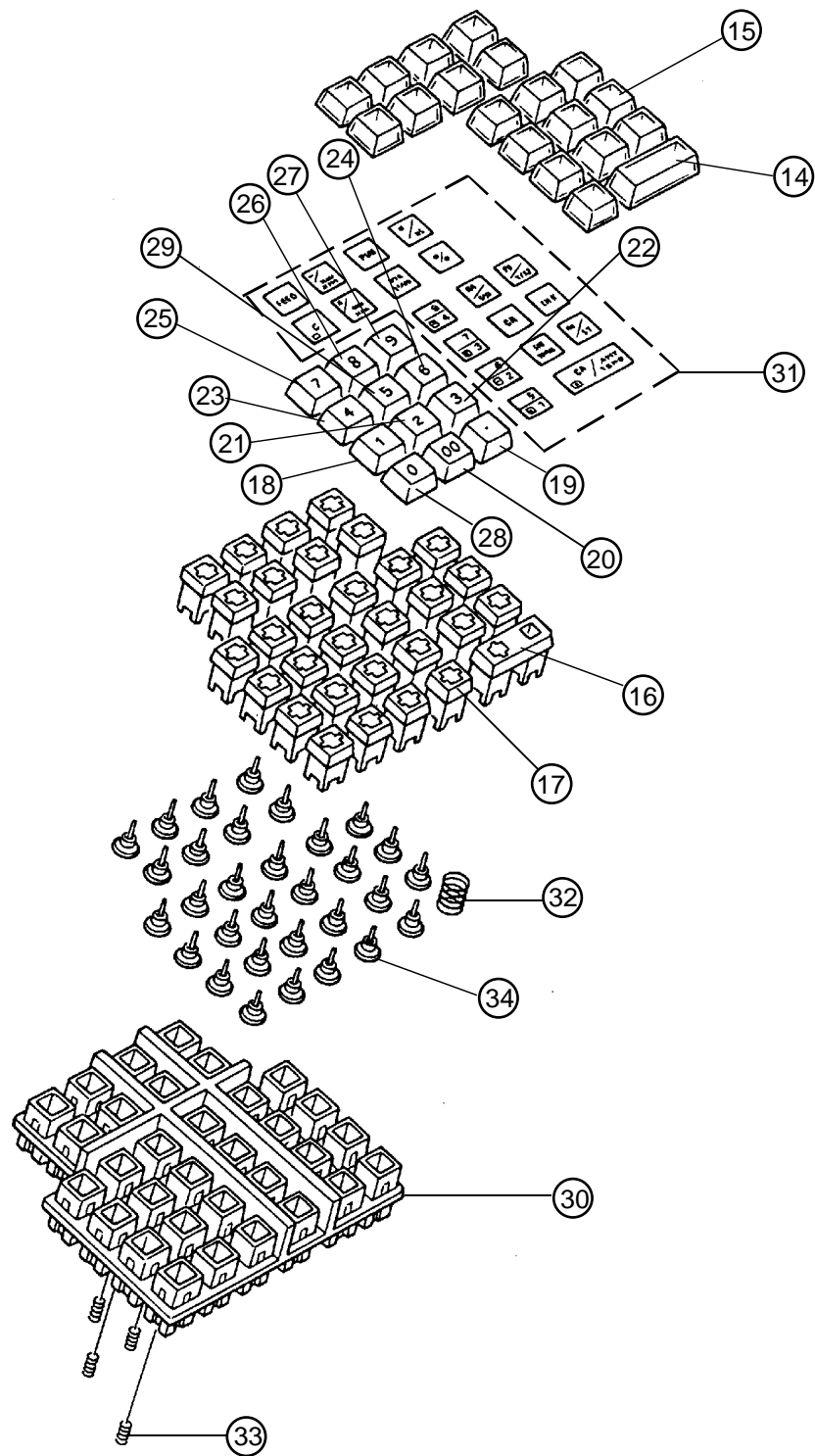

N	Item	Code No.	Parts Name	Specification	Version	M	Q	FOB Japan N.R.Yen Unit Price	R
			KEYBOARD ASS'Y						
N		6192 4830	Keyboard ass'y	E211671*2	U.S.A.,Canada		1		B
N		6192 4840	Keyboard ass'y	E211671*3	Except U.S.A.,Canada		1		B
	14	6221 3988	L cap E227	E210964-1	U.S.A.,Canada		1	23	C
	14	6221 3988	L cap E227	E210964-1	Except U.S.A.,Canada		2	23	C
	15	6221 4025	S cap E227	E311103-1	U.S.A.,Canada		18	13	C
	15	6221 4025	S cap E227	E311103-1	Except U.S.A.,Canada		15	13	C
N	16	6246 4030	L button E266	E210963-4	U.S.A.,Canada	10	1	34	C
N	16	6246 4030	L button E266	E210963-4	Except U.S.A.,Canada	10	2	34	C
N	17	6246 4020	S button E266	E311101-4	U.S.A.,Canada	20	30	13	C
N	17	6246 4020	S button E266	E311101-4	Except U.S.A.,Canada	20	27	13	C
N	18	6245 7250	S button 1	E311792-1		20	1	25	C
N	19	6245 7340	S button .	E311792-10		20	1	25	C
N	20	6245 7350	S button 00	E311792-11		20	1	25	C
N	21	6245 7260	S button 2	E311792-2		20	1	25	C
N	22	6245 7270	S button 3	E311792-3		20	1	25	C
N	23	6245 7280	S button 4	E311792-4		20	1	25	C
N	24	6245 7290	S button 6	E311792-5		20	1	25	C
N	25	6245 7300	S button 7	E311792-6		20	1	25	C
N	26	6245 7310	S button 8	E311792-7		20	1	25	C
N	27	6245 7320	S button 9	E311792-8		20	1	25	C
N	28	6245 7330	S button 0	E311792-9		20	1	25	C
N	29	6245 7360	S button 5	E311116-4		20	1	25	C
N	30	6246 1810	Keyboard frame	E211599-1			1	220	X
N	31	6246 2960	Plate sub Ass'y	E311948*1		5	1	70	X
N	31	6246 2910	Plate sub ass'y	E311949*2	U.S.A.,Canada	5	1	88	X
N	31	6246 2920	Plate sub ass'y	E311949*3	Except U.S.A.,Canada	5	1	79	X
	32	6221 0630	Coil spring A	E411104-1			5	3	C
	33	6221 0648	Coil spring B	E411104-2			4	3	C
	34	6245 3530	Key contact rubber	E411877-1			27	20	B
N	35	6246 1990	Button filer S	E412129-1	Except U.S.A.,Canada	5	1	52	X

5. UPPER CASE BLOCK

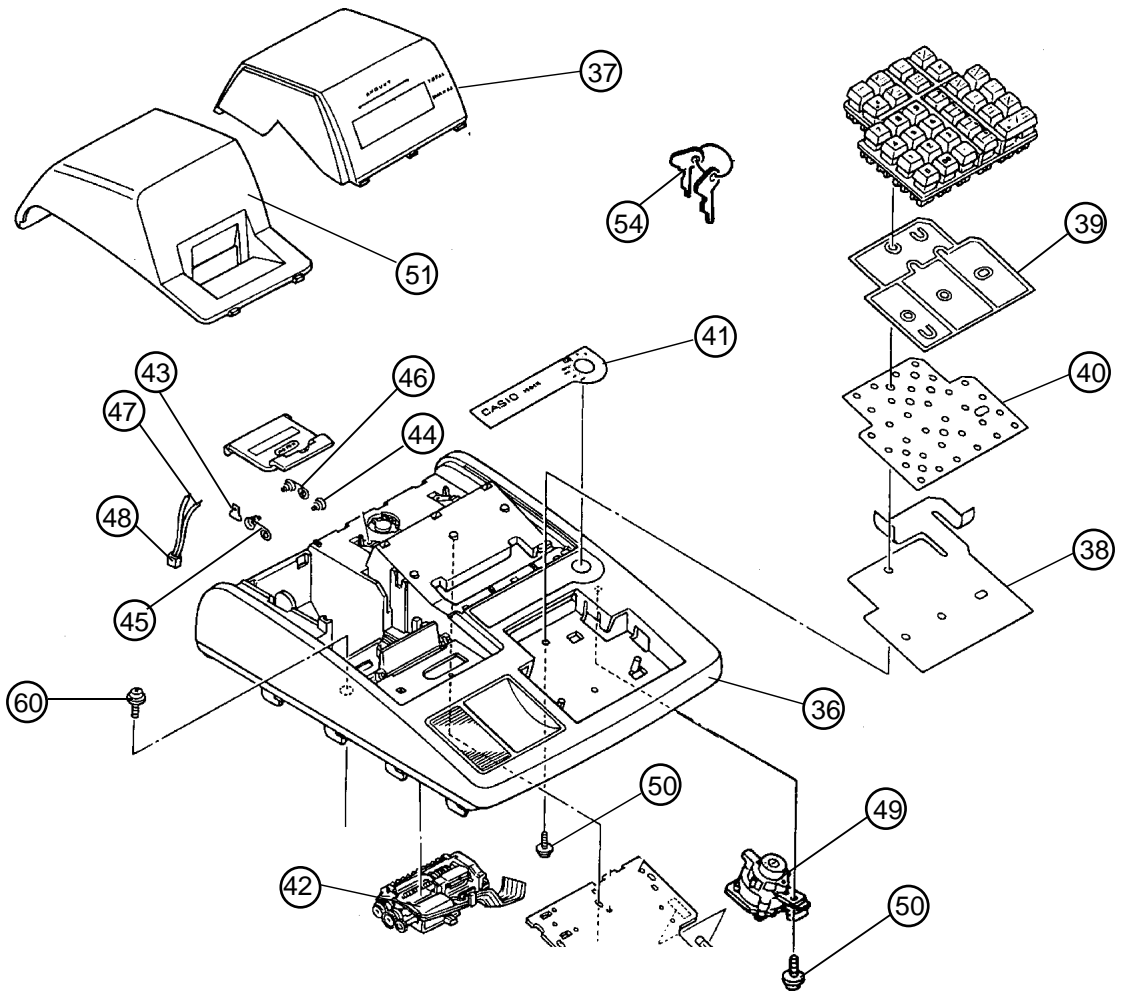

N	Item	Code No.	Parts Name	Specification	Version	M	Q	FOB Japan N.R.Yen Unit Price	R
			UPPER CASE BLOCK						
N	36	6246 1740	Upper case E266	E110368-1			1	800	X
N	37	6246 1790	Display plate E266B (110CR)	E110370-2			1	370	C
N	37	6246 1800	Display plate E267B (150CR)	E110370-3			1	370	C
N	38	6246 2740	FPC E266	E311855-1			1	110	B
N	39	6246 2750	Common sheet E266	E311856-1		10	1	44	B
N	40	6246 2760	Spacer E266	E311857-1		20	1	16	B
N	41	6246 2030	Mode key plate E266C (110CR)	E412138-3	U.S.A.,Canada	5	1	96	C
N	41	6246 2040	Mode key plate E266B (110CR)	E412138-4	Except U.S.A.,Canada	5	1	96	C
N	41	6246 2050	Mode key plate E267 (150CR)	E412138-5		5	1	96	C
N	42	1090 5329	Printer unit	M-42V-001-060MA	U.S.A.,Canada		1	1,150	A
N	42	1090 5322	Printer unit	M-42V-140-003MA	Except U.S.A.,Canada		1	1,150	A
	43	6322 4499	Battery spring A-G55	A42606-1		10	1	10	X
	44	6000 6091	Battery spring G67	A43656-1		10	1	5	X
	45	6001 0862	Battery spring B-1	P408-1		10	1	23	X
	46	6001 0871	Battery spring B-2	P409-1		10	1	23	X
N	47	6221 2284	Connector sub ass'y (Black)	E411265*1		10	1	24	X
N	48	6221 2292	Lead wire sub ass'y (Red)	E411266*1			1	24	X
N	49	6192 4970	Mode switch ass'y	E311944*1			1	370	B
	50	5112 0132	(+) Scew with washer	3x10 ZMC-3			6	2	X

6. OTHERS

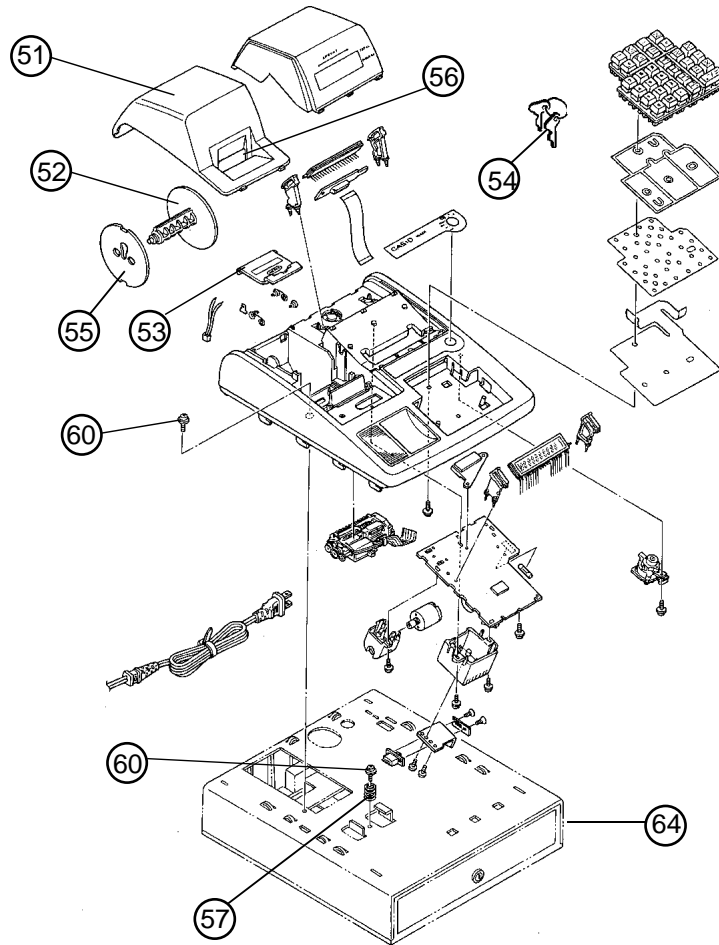

N	Item	Code No.	Parts Name	Specification	Version	M	Q	FOB Japan N.R.Yen Unit Price	R
			OTHERS						
N	51	6246 1760	Printer cover	E110369-1			1	270	C
N	52	6246 1830	Wind pulley	E311860-1			1	110	B
N	53	6246 1840	Battery cover E266	E311934-1		5	1	78	C
N	54	62464000	Key set sub ass'y	E312046*2	Europe,Germany, Other countries		1	180	B
N	54	6246 4010	Key set sub ass'y	E312046*3	U.S.A.,Canada,U.K.		1	180	B
N		6246 1870	OP key	E311853-1			2	100	B
N		6246 1910	PRG key	E311853-5			2	100	B
	55	6221 4029	Paper holding spool	E411393-1			1	38	B
	56	6215 8506	Paper cutter E94	E42592-1		20	1	20	C
N	57	6246 5750	Earth spring E266	E440019-1		10	1	34	X
N	58	6213 6341	FCC label	E31256-3	U.S.A.,Canada	20	1	13	X
N	59	6221 4933	F mark	E411809-1	Germany	20	1	11	X
	60	5112 0043	Screw with washer	3x8 ZMC-3			2	3	X
	61	5150 1617	Screw with washer	4x8 ZMC-3	Except U.S.A.,Canada	20	1	5	X
N	62	5440 0245	Washer	4 ZMC-3	Except U.S.A.,Canada	20	1	15	X
	63	5560 0368	Wire band	T-18S		10	1	2	X
N	64	6246 2870	Drawer unit (DL-1313)	E412153*2	U.S.A.,Canada		1	10,400	C
N	64	6246 2880	Drawer unit (DL-1817)	E412153*3	Except U.S.A.,Canada		1	10,400	C
N	64	6246 2890	Drawer unit (DL-2349)	E412161*1	Europe,Other countries		1	10,400	C
N	64	6246 2900	Drawer unit (DL-2749)	E412161*2	Europe,U.K., Other countries		1	10,400	C

7. PRINTER UNIT

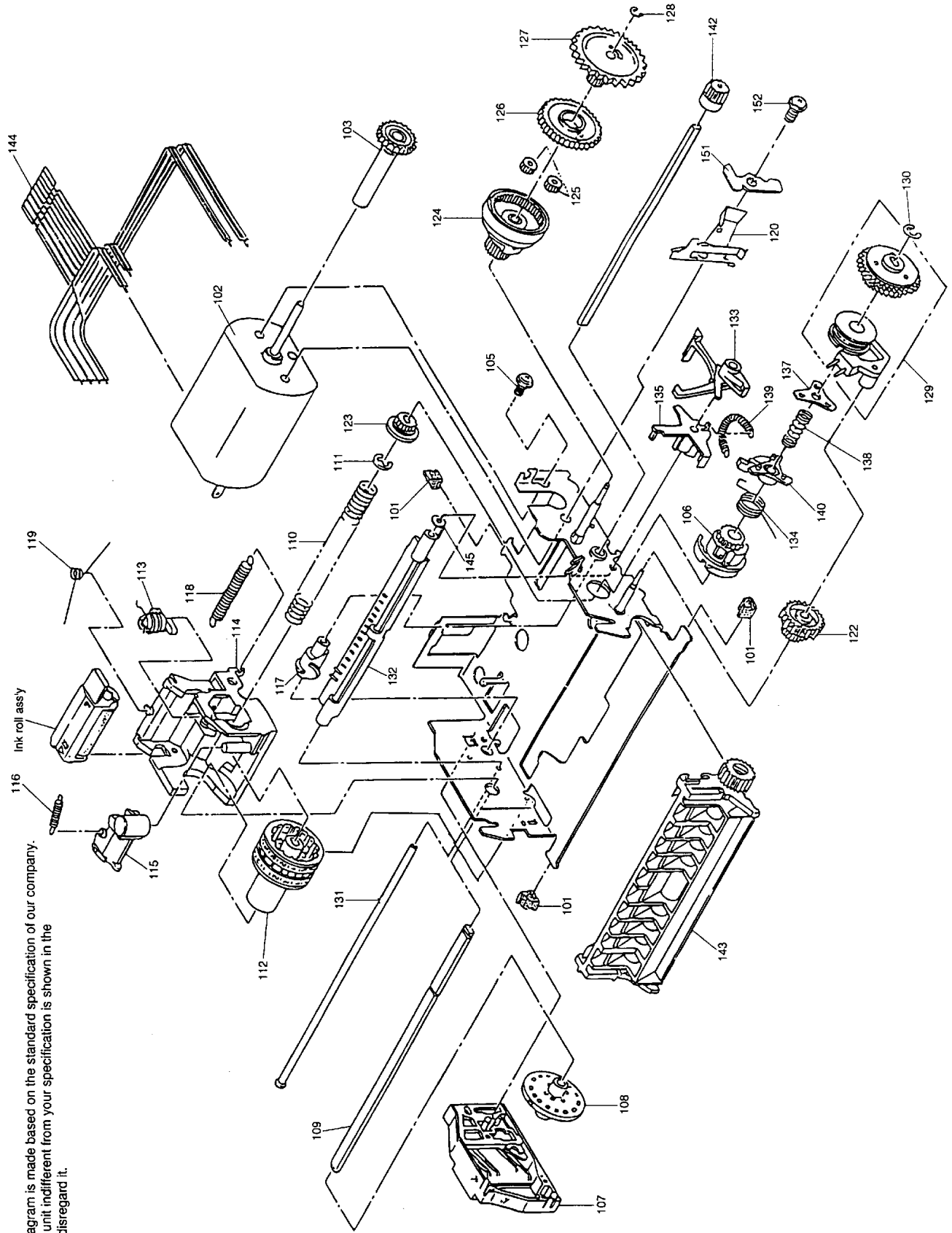

*The exploded diagram is made based on the standard specification of our company.
 When the part or unit, indiffernt from your specification is shown in the
 diagram, please disregard it.

7.PRINTER UNIT

N	Item	Code No.	Parts Name	Specification	Q	M	FOB Japan N.R.Yen Unit Price	R
	101	1903 0201	Rubber fitting	F801001050	3		15	X
	102	1908 7661	Motor	F818051010	1		600	A
	103	1908 7662	Motor gear	F817051010	1		25	C
	105	1908 7663	Cup screw M2x2.9	B040352118	2		12	X
	106	1908 7664	Paper feed drive gear ass'y	F815101000	1		140	C
	107	1908 7665	Detector ass'y	F815151000	1		180	A
	108	1903 2244	Detection wheel	F808152010	1		870	A
	109	1903 1976	Print wheel shaft	F808202010	1		100	X
	110	1903 0219	Print wheel spring	F801202020	1		23	C
	111	1903 0791	Retaining ring TYPE-E(1.5)	B150300311	1		2	X
N	112	1906 8901	Print wheel (for Japan)	M824009030	1		310	A
N	112	1906 8909	Print wheel (for USA, Canada)	M817001060	1		310	A
N	112	1906 8908	Print wheel (for except USA,Canada)	M824001140	1		310	A
N	113	1906 8902	Hammer transmission lever ass'y	F815210000	1	5	75	C
N	114	1906 8903	Carriage	F817208010	1	5	75	C
	115	1908 7317	Hammer (for Japan)	F818206010	1		100	C
N	115	1906 8907	Hammer (for except Japan)	F809201020	1		100	C
	116	1903 2246	Hammer return spring	F808201020	1		18	C
	117	1908 7676	Print cam	F817201020	1		63	C
	118	1903 2298	Carriage spring	F812201020	1	5	75	C
	119	1908 7670	Ink roll spring	F817201010	1		25	C
	120	1908 7318	Selective pawl spring	F818209010	1	10	50	C
	122	1909 1858	Paper feeding transmission gear	F815212010	1		38	C
	123	1903 0220	Paper feeding ratchet wheel	F801202030	1	10	23	C
N	124	1906 8904	Print change over cam	F815215010	1	5	50	C
	125	1903 0234	Planet gear	F801206020	2		30	C
	126	1903 0235	Selecting drive gear	F801206030	1		23	C
	127	1908 7674	Reduction gear	F817203010	1		25	C
	128	1903 0792	Retaining ring TYPE-E(1.2)	B150300212	1		2	X
N	129	1906 8905	Coil selective gear ass'y	F818230000	1		200	C
	130	1903 0791	Retaining ring TYPE-E(1.5)	B150300311	1		2	X
	131	1903 1968	Positioning shaft	F806206010	1		40	X
	132	1903 2280	Positioning plate	F808205010	1		100	X
	133	1903 0293	Selecting ratchet	F804204010	1		30	X
	134	1903 0264	Trigger lever spring	F803204020	1	10	12	C
	135	1908 7675	Return lever	F815207010	1		38	C
	137	1903 0230	Trigger plate	F801205100	1		31	C
	138	1903 0231	Trigger plate spring	F801205110	1	10	8	C
	139	1903 2293	Return lever spring	F810205020	1		18	C
	140	1903 0226	Trigger lever	F801205060	1		23	C
	141	1903 1972	Platen shaft	F806207010	1		100	X
	142	1903 0241	Carriage feeding gear	F801211020	1		23	C
N	143	1908 7321	Platen ass'y	F818251000	1	20	290	X
N	144	1906 8910	Jumper wire	F818601010	1	10	24	X
	145	1906 8906	Plain washer G	F817210010	1		25	X
	151	1908 7672	Selective pawl spring holder	F818202020	1		25	X
	152	1903 0674	Cup screw 2x3.5	B040351111	1		6	X

8. DRAWER UNIT
DL-1313 (for U.S.A.)

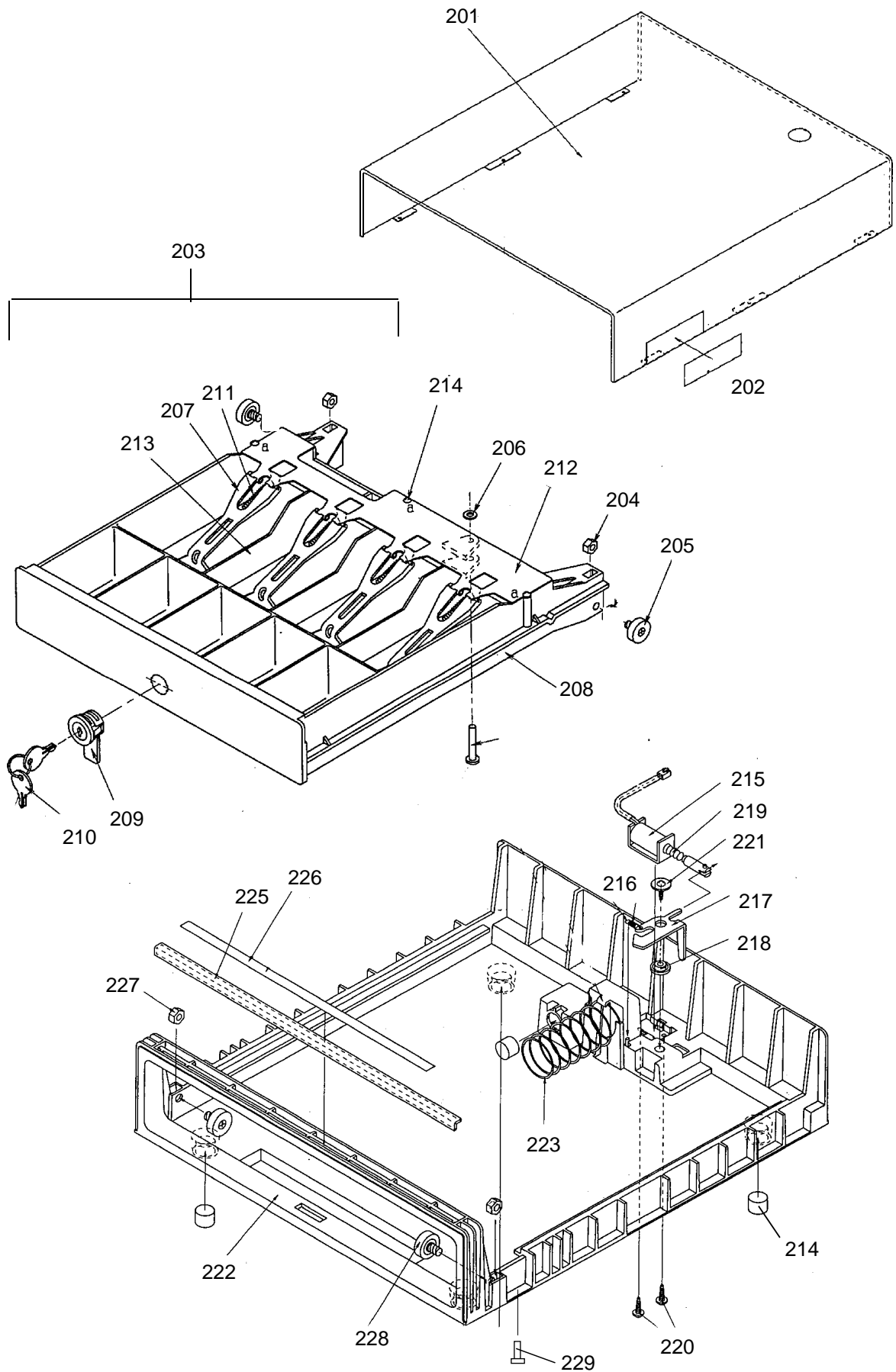

DL-1313 (for U.S.A.)

N	Item	Code No.	Parts Name	Specification	M	Q	FOB Japan N.R.Yen Unit Price	R
N	201	6246 7446	Top cover	E211698A-1		1	4,200	X
N	202	6246 6501	Drawer label DL-1313	E311416-36	20	1	22	X
N	203	6192 6980	Drawer ass'y	E211677*2		1	4,200	C
	204	5150 1643	Nut	6	20	2	6	C
N	205	5500 0878	Roller	DR-19B2		2	150	B
	206	5580 1452	CS ring	CSTW-5		1	5	X
	207	6221 4902	Bill holder	ZD18931		4	47	A
N	208	6246 2620	Drawer EDL-IG	E110325A-5		1	890	X
N	209	6246 4960	Cylinder lock	E311950*1		1	500	B
N	210	6246 5320	Cylinder key	E412059-1		2	200	B
N	211	6246 5220	Bill holder spring	E412160-1	20	4	22	A
N	212	6246 6571	Bill holder fixing plate	E311873-1		1	170	C
N	213	6246 6585	Partition plate	E340010-5		3	200	B
	214	5860 0679	Screw	3X8 ZMC-3	20	3	6	X
N	215	5500 0885	Solenoid ass'y	STC-06UB-332T		1	650	B
	216	5580 1461	Lock spring	ZD03441-A		1	15	C
N	217	6246 4940	Hook lever	E311876-1	5	1	80	X
N	218	6246 5020	Hook lever shaft	E412071-1	10	1	34	X
N	219	6246 6564	Solenoid spring	E440034-1	10	1	26	C
N	220	5161 3210	Screw	3X5 ZMC-3	20	2	3	X
N	221	5151 3236	Screw with washer	4X18 ZMC-3	20	1	3	X
N	222	6246 6515	Bottom case	E110360-1		1	4,200	X
N	223	6246 6522	Push spring	E412137-1	20	1	22	C
N	224	6246 6529	Rubber foot	E412136-1	10	5	34	X
N	225	6246 6543	Reinforcement	E412171-1		1	110	X
N	226	6246 6557	Damper rubber	E440023-1	10	1	34	X
N	227	5150 1643	Nut	6	20	2	4	X
N	228	5500 0878	Roller	DR-19B2		2	190	B
	229	5111 2679	Tapping screw	3x8	50	6	2	X

DL-1817 (for Europe, U.K., Germany, Other countries)

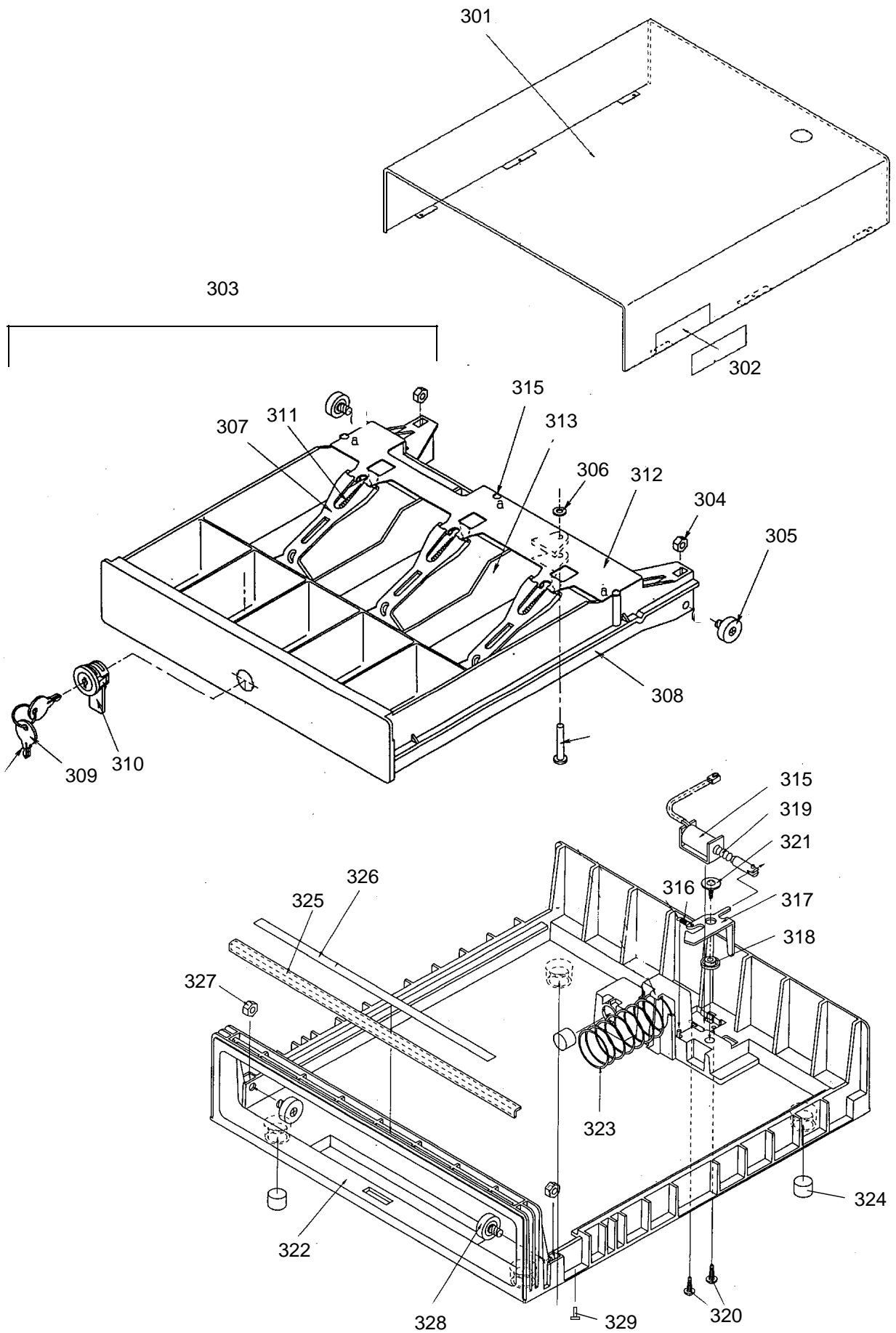

DL-1817 (for Europe, U.K.,Germany,Other counties)

N	Item	Code No.	Parts Name	Specification	M	Q	FOB Japan N.R.Yen Unit Price	R
N	301	6246 7446	Top cover	E211698A-1		1	4,200	X
N	302	6246 6508	Drawer label DL-1817	E311416-37	20	1	22	X
N	303	6192 6980	Drawer ass'y	E211677*2		1	4,200	C
	304	5150 1643	Nut	6	20	2	6	X
N	305	5500 0878	Roller	DR-19B2		2	150	B
	306	5580 1452	CS ring	CSTW-5		1	5	X
	307	6221 4902	Bill holder	ZD18931		3	47	A
N	308	6246 2620	Drawer EDL-IG	E110325A-5		1	890	X
N	309	6246 5320	Cylinder key	E412059-1		2	200	C
N	310	6246 4960	Cylinder lock	E311950*1		1	500	B
N	311	6246 5220	Bill holder spring	E412160-1	20	3	22	A
N	312	6246 6578	Bill holder fixing plate	E311973-1		1	170	C
N	313	6246 6585	Partition plate	E340010-5		2	200	B
	314	5860 0679	Screw	3X8 ZMC-3	20	3	6	X
N	315	5500 0885	Solenoid ass'y	STC-06UB-332T		1	650	B
	316	5580 1461	Lock spring	ZD03441-A		1	15	C
N	317	6246 4940	Hook lever	E311876-1	5	1	80	X
N	318	6246 5020	Hook lever shaft	E412071-1	10	1	34	X
N	319	6246 6564	Solenoid spring	E440034-1	10	1	26	C
N	320	5161 3210	Screw	3X5 ZMC-3	20	2	3	X
N	321	5161 3236	Screw with washer	4X18 ZMC-3	20	1	3	X
N	322	6246 6515	Bottom case	E110360-1		1	4,200	X
N	323	6246 6522	Push spring	E412137-1	20	1	22	C
N	324	6246 6529	Rubber foot	E412136-1	10	5	34	X
N	325	6246 6543	Reinforcement	E412171-1		1	110	X
N	326	6246 6557	Damper rubber	E440023-1	10	1	34	X
N	327	5440 0252	Nut	6	20	2	4	X
N	328	5500 0878	Roller	DR-19B2		2	150	B
N	329	5111 2679	Tapping screw	3x8	50	6	2	X

DL-2749 (for Europe,U.K., Other countries)

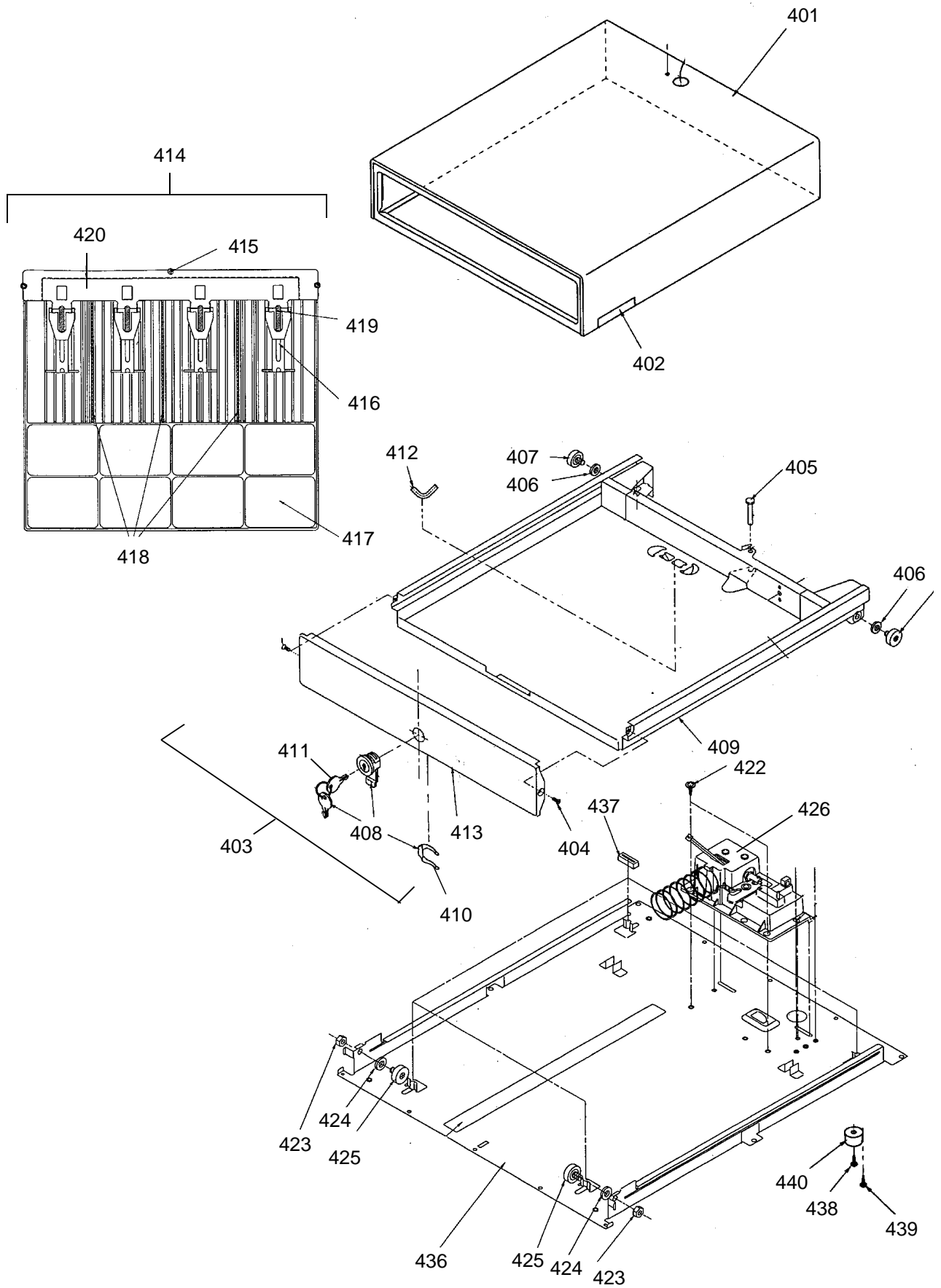

DL-2749 (for Europe, U.K., Other countries)

N	Item	Code No.	Parts Name	Specification	M	Q	FOB Japan N.R.Yen Unit Price	R
N	401	6246 5090	Box sub ass'y	E311926*1		1	4,200	X
N	402	6246 5120	Drawer label DL-2749	E311977-2	20	1	22	X
N	403	6192 6329	Drawer ass'y	E311955*1		1	4,200	C
	404	5150 1652	Tapping screw (+)	3.5X8 ZMC-3...		2	5	X
	405	5200 0106	Rivet	5X30		1	10	X
	406	5301 5018	Washer	6X13X1 ZMC-3	50	2	2	X
	407	5800 0043	Roller	DR-19B-1.0		2	80	B
	408	6221 4900	Cylinder lock	ZD20025		1	300	C
N	409	6246 4950	Drawer sub ass'y	E311927*1		1	2,800	C
N	410	6246 2790	Ring EDL	E412061-1		1	100	X
N	411	6246 5320	Cylinder key ED14	E412059-1		2	200	C
N	412	6246 5030	Earth spring	E412092-1	10	1	34	X
N	413	6246 5180	Front panel	E211607-1		1	600	X
N	414	6192 6360	Bill/Coin case ass'y	E110387*3		1	2,100	C
	415	5860 0679	Tapping screw (+)	3X8 ZMC-3..	20	3	6	X
	416	6221 4902	Bill holder	ZD18931		4	47	A
N	417	6221 4910	Bill/Coin case	ZD43751		1	1,120	C
	418	6221 4911	Partition plate	ZD43652		3	330	B
N	419	6246 5220	Bill holder spring	E412160-1		4	22	A
N	420	6246 5230	Bill holder fixing plate	E211620-1		1	540	C
N	421	6192 6281	Bottom case ass'y	E211678*1		1	2,470	X
	422	5112 0035	Screw with washer	4X6 ZMC-3	20	2	6	X
	423	5150 1643	Nut	6	20	2	6	X
	424	5301 5018	Flat washer	6X13X1 ZMC-3	50	2	2	X
	425	5500 0619	Roller	DR-19B1		2	75	A
N	426	6192 6313	Lock ass'y	E211680*1		1	980	B
N	427	3000 7252	Solenoid ass'y	STC-08A-332T		1	650	B
N	428	5161 5123	Screw (+)	3X8 ZMC-3	20	2	3	X
N	429	5440 0224	Screw	4X14 ZMC-3..	20	1	3	X
	430	5580 1461	Lock spring	ZD03441-A		1	15	C
N	431	6246 4890	Lock fixing stand	E211622-1		1	180	X
N	432	6246 4940	Hook lever	E311876-1	5	1	80	X
N	433	6246 5010	Push spring	E412069-1		1	100	C
N	434	6246 5020	Hook lever shaft	E412071-1	10	1	34	X
N	435	6246 5210	Solenid spring	E412158-1	20	1	22	C
N	436	6246 4900	Bottom plate	E211623-1		1	980	X
N	437	6246 5040	Damper rubber	E412117-1		4	360	X
	438	5150 1644	Screw with washer	4X16 ZMC-3.....	20	4	6	X
	439	5150 1645	Screw with washer	3X5 ZMC-3.....	20	8	6	X
	440	6221 4893	Rubber foot	ZD01013-A		4	50	X

DL-2349 (for Europe, Canada, Other countries)

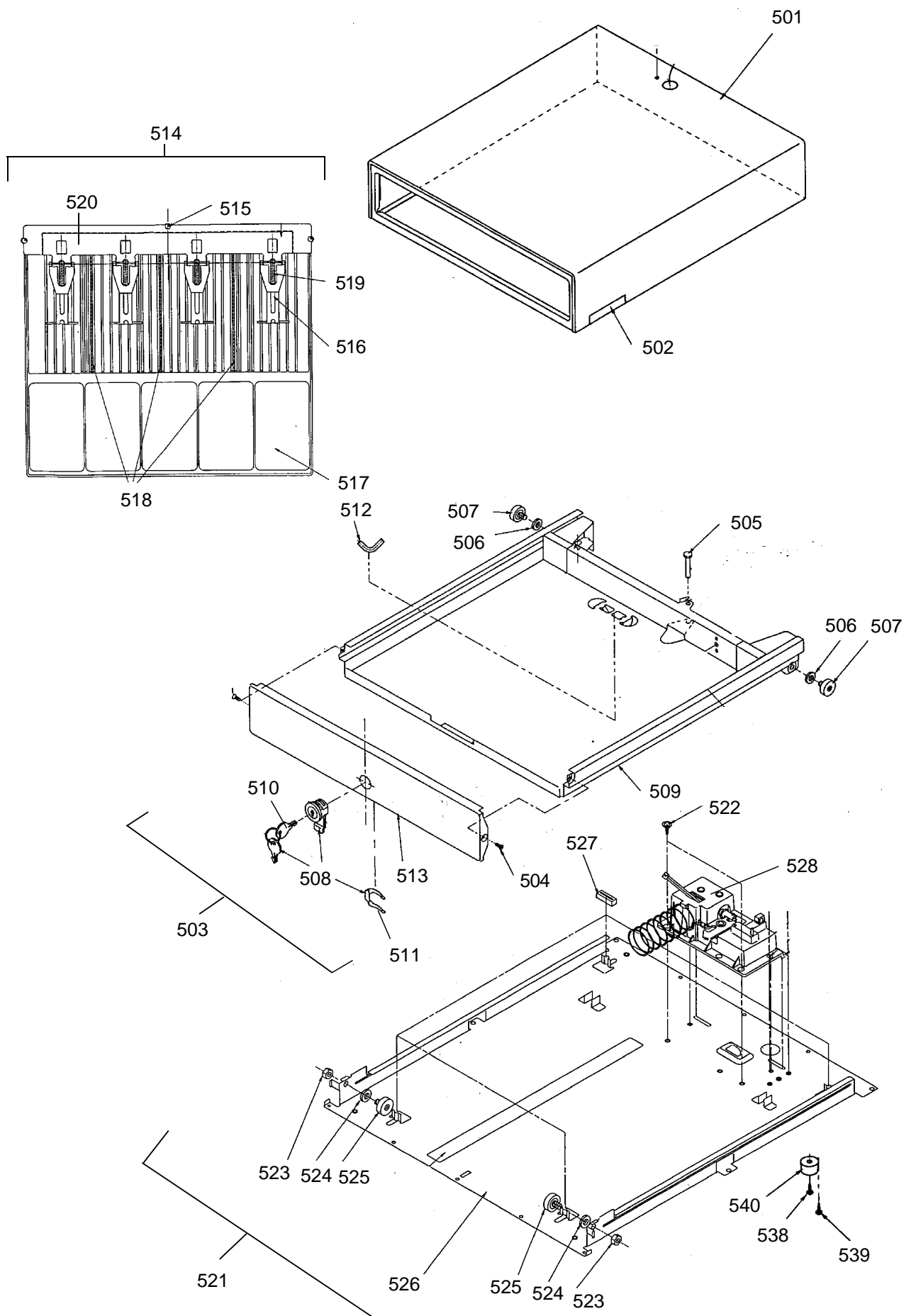

DL-2349 (for Europe, Canada, Other countries)

N	Item	Code No.	Parts Name	Specification	M	Q	FOB Japan N.R.Yen Unit Price	R
N	501	6246 5090	Box sub ass'y	E311926*1		1	4,200	X
N	502	6246 5110	Drawer label DL-2349	E311977-1	20	1	22	X
N	503	6192 6329	Drawer ass'y	E311955*1		1	4,200	C
	504	5150 1652	Tapping screw (+)	3.5X8 ZMC-3...		2	5	X
	505	5200 0106	Rivet	5X30		1	10	X
	506	5301 5018	Flat washer	6X13X1 ZMC-3	50	2	2	X
	507	5800 0043	Roller	DR-19B-1.0		2	80	A
	508	6221 4900	Cylinder lock	ZD20025		1	300	C
	509	6246 4950	Drawer sub ass'y	E311927*1		1	2,800	C
N	510	6246 5320	Cylinder key	E412059-1		2	200	C
	511	6246 2790	Ring EDL	E412061-1		1	100	X
N	512	6246 5030	Earth spring	E412092-1	10	1	34	X
N	513	6246 5180	Front panel	E211607-1		1	600	X
N	514	6192 6340	Bill/Coin case ass'y	E110387*1		1	2,100	C
	515	5860 0679	Tapping screw (+)	3X8 ZMC-3..	20	3	6	X
	516	6221 4902	Bill holder	ZD18931		4	47	A
	517	6221 4909	Bill coin case	ZD43651		1	1,300	C
	518	6221 4911	Partition plate	ZD43652		3	330	B
N	519	6246 5220	Bill holder spring	E412160-1	20	4	22	A
N	520	6246 5230	Bill holder fixing plate	E211620-1		1	540	C
N	521	6192 6281	Bottom case ass'y	E211678*1		1	2,470	X
	522	5112 0035	Screw with washer	4X6 ZMC-3	20	2	6	X
	523	5150 1643	Nut	6...	20	2	6	X
	524	5301 5018	Flat washer	6X13X1 ZMC-3	50	2	2	X
	525	5500 0619	Roller	DR-19B1		2	75	A
N	526	6246 4900	Bottom plate	E211623-1		1	980	X
N	527	6246 5040	Damper rubber	E412117-1		4	360	X
N	528	6192 6313	Lock ass'y	E211680*1		1	980	B
N	529	3000 7252	Solenoid ass'y	STC-08A-332T		1	650	B
N	530	5161 5123	Screw (+)	3X8 ZMC-3	20	2	3	X
N	531	5440 0224	Screw with washer	4X14 ZMC-3..	20	1	3	X
	532	5580 1461	Lock spring	ZD03441-A		1	15	C
N	533	6246 4890	Lock fixing stand	E211622-1		1	180	X
N	534	6246 4940	Hook lever	E311876-1	5	1	80	X
N	535	6246 5010	Push spring	E412069-1		1	100	C
N	536	6246 5020	Hook lever shaft	E412071-1	10	1	35	X
N	537	6246 5210	Solenoid spring	E412158-1	20	1	22	C
	538	5150 1644	Screw with washer	4X16 ZMC-3.....	20	4	6	X
	539	5150 1645	Screw with washer	3X5 ZMC-3.....	20	8	6	X
	540	6221 4893	Rubber foot	ZD01013-A		4	50	X