

§ 1. OUTLINE



This is a multi-function and complex watch for gentlemen, which has been developed as a member of the well-reputed "89-series watches" combining the analog and digital watch functions together. It features the unique design and specifications plus application of the special-form drilled LC display panel and the analog electromagnetic correction system.

(Cal. 8940)



One of the biggest features of this watch is the LC (liquid crystal) display panel that doubles a dial plate, thus obtaining more variety of designs of watch by changing the print colors of the LC display panel (upper surface of the upper deflecting plate). (Cal. 8943)

§ 2. FEATURES

- 1) The electronic watch of quartz crystal oscillation type with no center second and LC (liquid crystal) display.
- 2) Analog watch section:
 - 20-second step movement with no center second.
 - The time correction applies the electromagnetic correction system by push-buttons.
 - The 0-second resetting of the analog section couples that of the digital section.
 - The simplification is realized for the movement with disuse of the dial-side mechanism.
- 3) Digital watch section:
 - The quick and analog-type reference is possible for the present time with application of the circle segment to the second display.
 - With the normal time display, the calendar display, the alarm, the timer and the stopwatch each. The simultaneous use is possible for both the timer and the stopwatch.
 - The 12-/24-hour switching function applied (with interlocking of the alarm display to the period switching of the time display).
 - The fully automatic calendar incorporated (including the leap years).
 - The quick setting system functions in the correction mode.
- 4) The number of component parts is reduced with facilitation attained for the disassembly and assembly by adapting the hook-system for both the LC display panel supporter and the supporter for plate complete (I).
- 5) The power cell life indicator functions through flashing of the colon at the digital display part when the output voltage of the power cell lowers.
- 6) The alarm monitor is incorporated.

§ 3. SPECIFICATIONS

Caliber No.	8940A/C-02		8943-02	
Module	Size	: 27.4 x 26.0mm	←	
	Thickness	: 4.55mm (Power cell part 4.75mm)	5.05mm (5.25mm)	
Accuracy	±15 sec./month at normal temperatures		←	
Oscillation	32,768Hz		←	
Digital section	Method of display	EF twist-type nematic LC (2-split multiplex driving)	←	
		4 digits +60 (circle segment) + 13 marks	66 (circle segment)	
	Display functions	Time	AM/PM, hour, minute/second (circle segment) plus 12/24-hour switching function	←
		Calendar	Date/day plus month & year (1980~2019) at moment of correction	←
		Alarm	AM/PM, hour & minute (12/24-hour switching function coupling to time display)	←
		Chime	ON/OFF	
		Timer	Hour, minute & second (circle segment) with 12-hour subtraction system	←
Stopwatch	Minute, second/1/100 sec. (by switch of display modes) with 60-min. counting	←		
Analog section	Means of display	Hour & minute hands with 20-sec. movement	←	
	Correction/setting of display	Electromagnetic method with push of button	←	
	Converter	Bipolar step motor	←	
Additional functions	<ul style="list-style-type: none"> •Power cell life indicator •Alarm monitor •12/24-hour switching function •Fully automatic calendar (1980~2019) •Instant manual return 		←	
Effective temperature range	±0°C ~ +60°C (32°F ~ 140°F)		←	
Integrated circuit	C/MOS-LSI (1 unit)		←	
Power cell	Parts No.	280-30 (SR1120W) Ag ₂ O/KOH	←	
	Capacity	45mAH	←	
	Lifetime	About 2 years (90-sec. ring of alarm per day)	←	
	Nominal voltage	1.55V	←	
	Size	11.6φ x 2.1mm ^t	←	

The difference between Cal. Nos. 8940A and 8940C exists only in the LC display panel as follows.

Cal. Nos.	Points of difference	LC display panel
		Print + deflecting plate color
8940A		Blue
8940C		Brown

Cal. 8940

(LC display panel)



Color (printed on upper face of upper deflecting plate) differing at this area

•Combination between LC display panel (4 types) and reflecting plate

Color of LC display panel (Parts No.)	Color of reflecting plate
Black (281-706)	Silver
Birdy brown (281-708)	Gold
White (281-709)	Silver
Gray (281-711)	Silver

Cal. 8943

§ 4. HANDLING INSTRUCTIONS (The flashing area is shown by ○.)

1) Nomenclature (Cal. 8940)

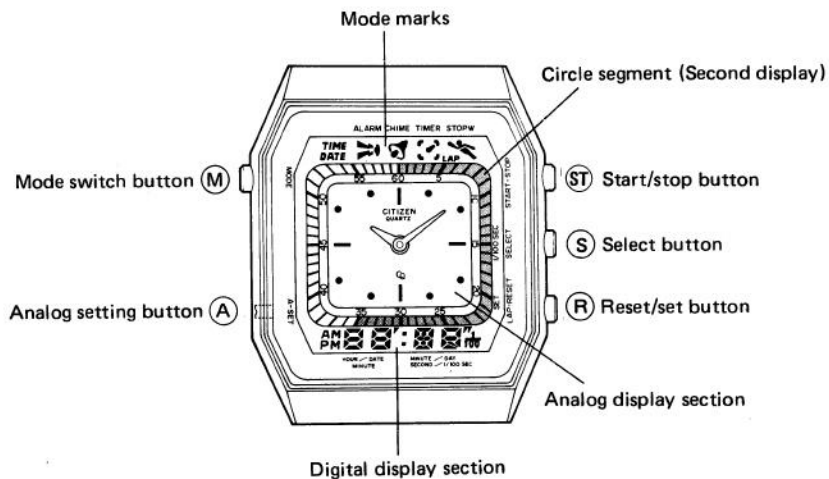

2) Switching of display

The switching is given to each display by pushing (M) button.

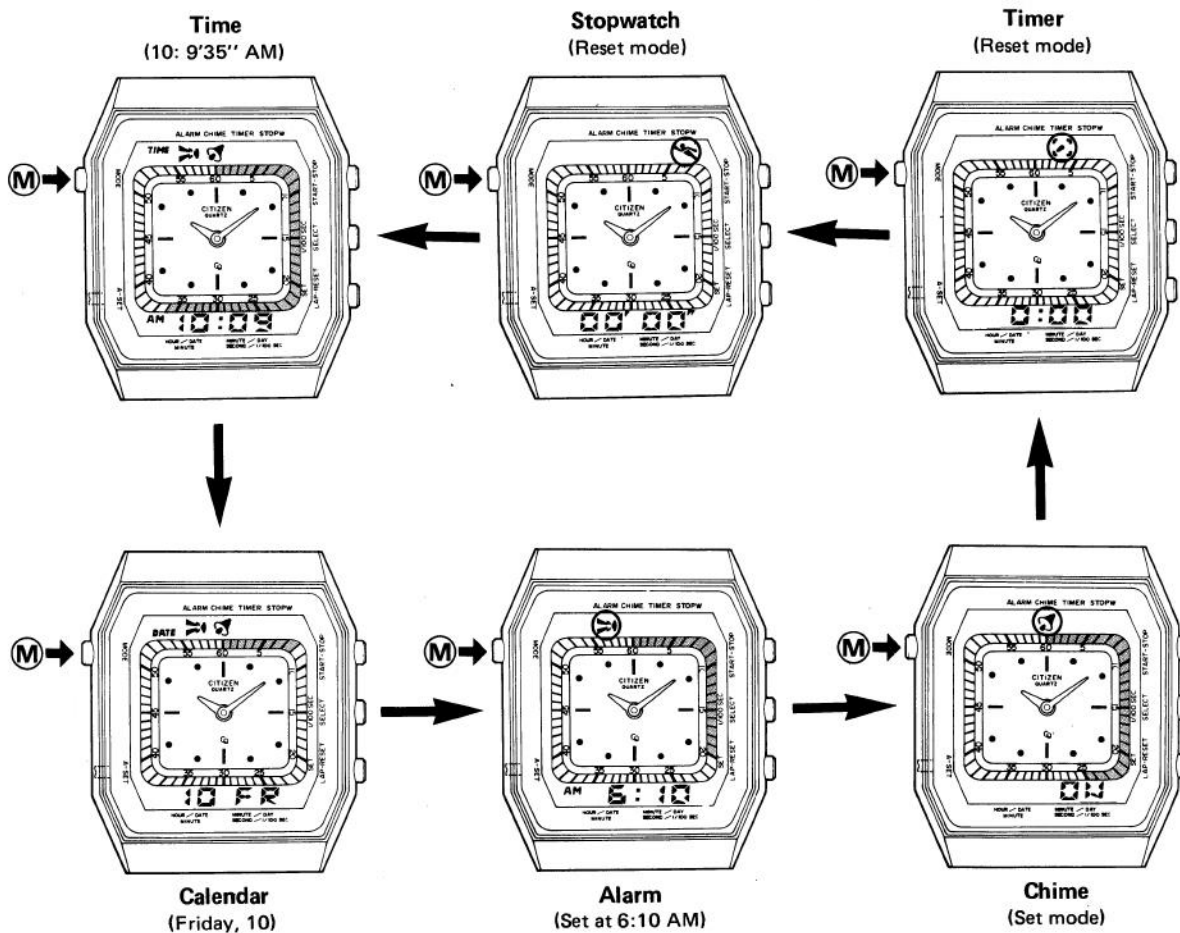

3) Nomenclature (Cal. 8943)

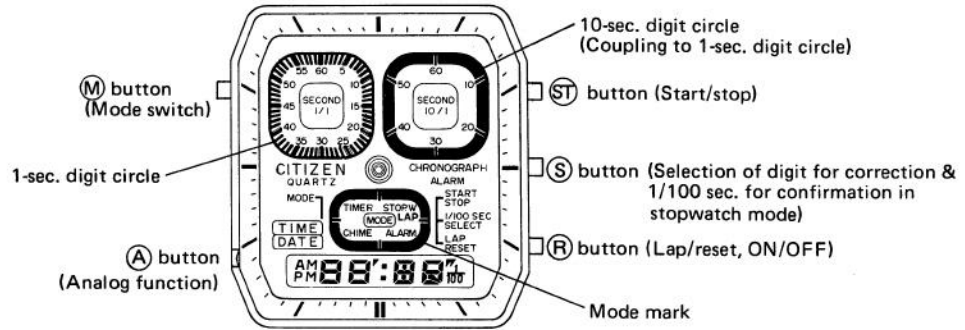

4) Mode switching

The mode of display is switched in the following sequence with every push of **M** button.

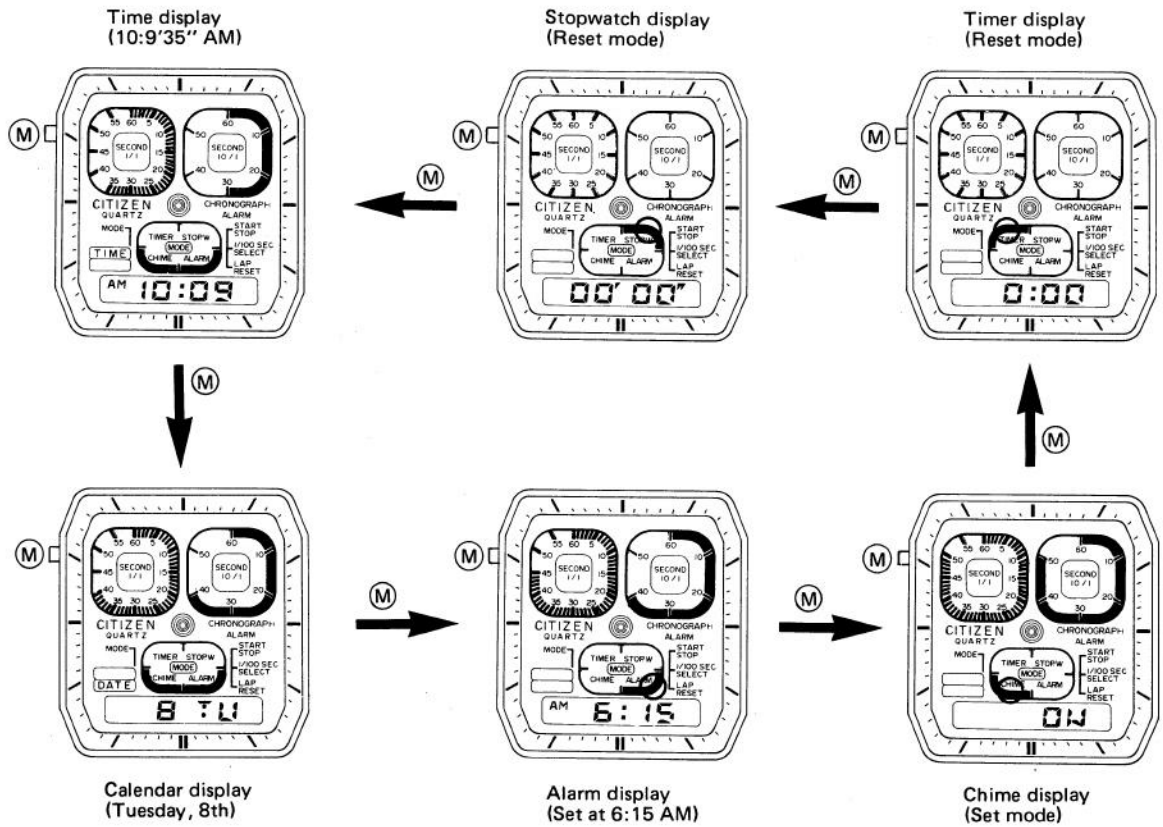

(The flashing area is shown by ○)

The handling method of the digital section is described via the diagram below.

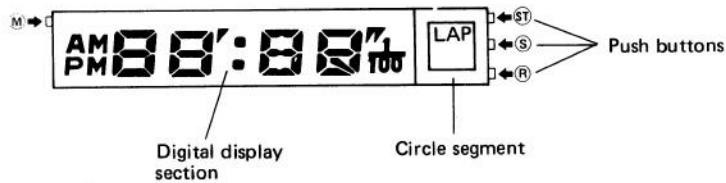

● 12-/24-hour switching

With simultaneous push of both (R) and (ST) buttons in the mode of the normal time display, the switching is possible between AM/PM 12H and 24H. The AM/PM is not displayed in the 24 hour display.

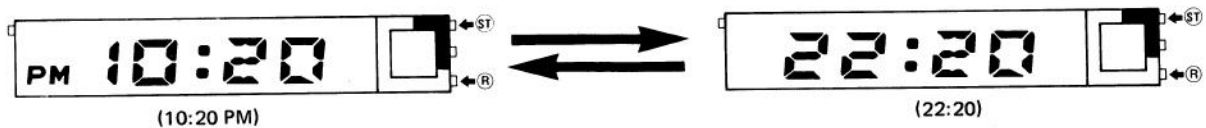

The alarm rings for the alarm monitor while the buttons are pushed.

● Alarm monitor

The circle segment shown in the right diagram blinks in a 1/4 cycle with a simultaneous push of (ST) and (R) buttons and in any mode of display. At the same time, an alarm monitor tone (sound of confirmation) identical to an alarm tone is produced.

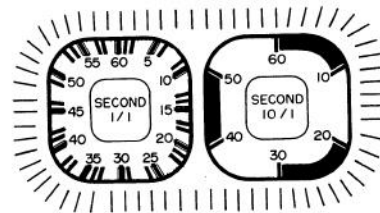

3) Time setting

Digital section

The time can be set via (R) button after calling out the digit to be corrected with push of (S) button.

The quick setting (8Hz signal) is possible with push of (R) button for more than about one second in the setting mode. In this case, the flashing ceases.

The setting is carried out in the following sequence.

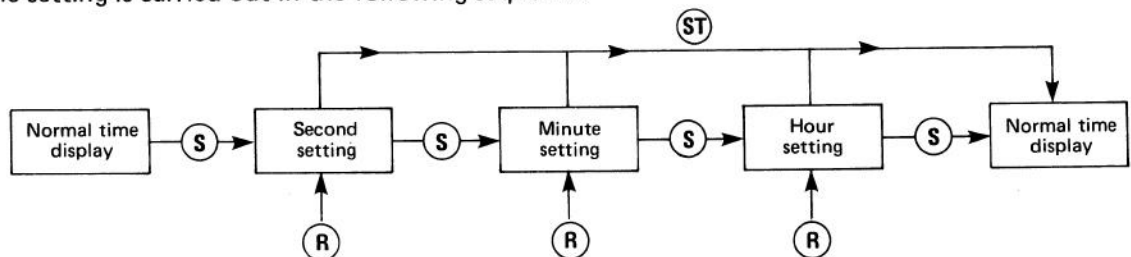

* (S)-button must be pushed for about one second to call out the second setting.

- The circle segment performs the sequential cumulative display of one segment per second to secure the full glowing at 60 seconds and then the full lights-out after 0.5 second, and then carries out the cumulative display again from one second.
- One minute is carried in case the 0-second resetting is carried out in the range of 30 ~ 59 seconds.

[Analog section]

- The application is possible for the "dual time" since the digital and analog watch sections can be set independently.

[Time setting]

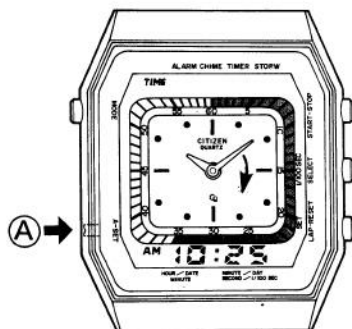

The setting is possible in any display mode with push of (A) button. However, the first push of the button functions to stop the alarm ringing when the alarm is ringing.

And the quick setting mode is secured if (A) button is pushed for about one second or more. For the fine adjustment, 20 seconds are advanced with every single-shot of push. The time setting is possible only forward (the direction indicated by the arrow in the left diagram)

Setting of same time for both analog and digital watch sections:

The digital time is set first, and then the analog time is set to the digital time.

(Ex.) Setting of analog minute hand at digital time of 00:15'N"

Digital "minute"	Digital "second"	Setting of analog minute hand
15	$0 \leq N < 20$	To be set to position of 15 minutes
	$20 \leq N < 40$	One push given after setting the minute hand to position of 15 minutes
	$40 \leq N < 60$	Two pushes given after setting the minute hand to position of 15 minutes

• "Second" setting

The 0-second resetting is also given at the analog section in coupling to setting of the digital "second". This method is applied to correction of the normal gains or losses.

In case the 0-second resetting is given at N second, the analog and digital changes are as shown below.

Before 0-second resetting	After 0-second resetting		
Digital "second"	Digital "second"	Digital "minute"	Analog "minute"
$0 \leq N \leq 29$	00	No change	Waiting for N-second counting(*1)
$30 \leq N \leq 39$	00	Carry of one minute	+2(*2)
$40 \leq N \leq 59$	00	Carry of one minute	+1

(*1) The count waiting is cancelled in case the analog setting is carried out during the count waiting.

(*2) This watch features 20-second step movement, and accordingly 20 seconds advance with every step movement of the hands.

In this connection, the two movements (40 seconds) are given if the 0-second resetting is carried out in the range of 30 ~ 39 seconds.

4) Calendar setting

The digit to be corrected is called out with push of (S) button, and then the setting is carried out with push of (R) button.

- The setting of the years is possible from 1980 to 2019.
- In case the non-existing day is set, the first day of the following month is set in the normal calendar display.

The quick setting is possible by pushing (R) button for about one second or more in the setting mode.

The setting is carried out in the following sequence.

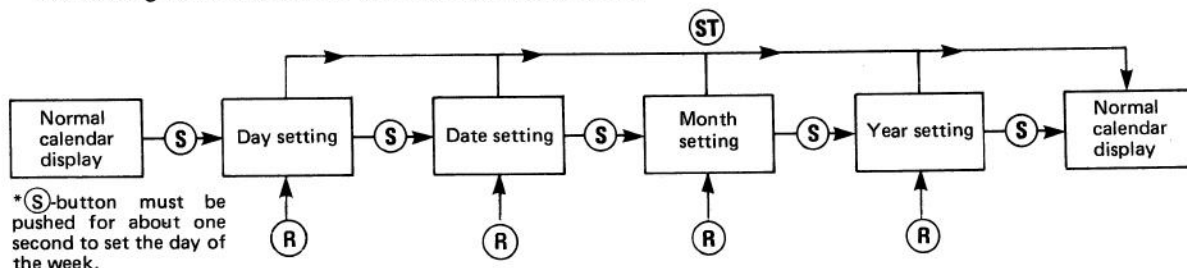

5) Alarm operation

(1) ON and OFF of alarm

The ON (setting time display) and OFF of the alarm function are switched alternately with every push of (R) button in the mode of the alarm normal display.

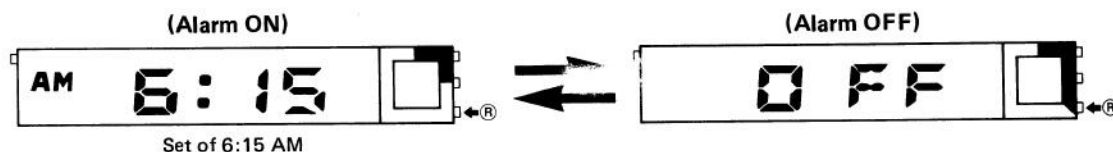

(2) Setting of alarm

The digit to be corrected is called out with push of (S) button, and then the setting is carried out via (R) button.

- The alarm mark is shown under the time/calendar display and when the alarm is ON.
- The switching between AM/PM 12H and 24H interlocks the period system of the time display.

The quick setting is possible by pushing (R) button for about one second or more in the setting mode.

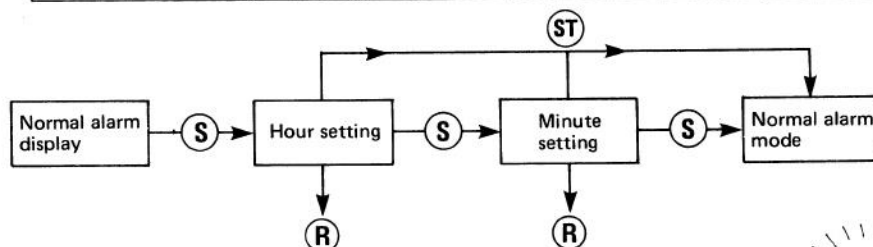

* (S)-button must be pushed for about one second for call-out in the hour setting.

In the alarm ringing state, the segments feature the ¼-second synchronous flashing with every two segments for the circle segment as shown in the right diagram.

The alarm ringing can be stopped anytime by pushing any of the push-buttons.

(The same flashing is given also at the time-up moment of the timer function or the alarm monitor.)

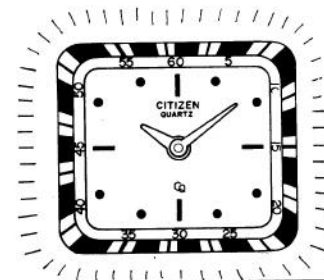

6) Setting of chime

The ON and OFF switch alternately with every push of (R) button in the chime display mode. In the mode of ON, the alarm sounds twice in synchronization with every hour on the hour.

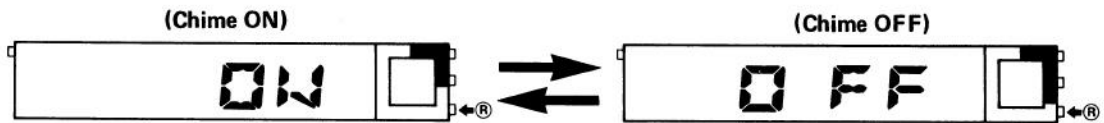

7) Operation of timer

- The timer can be set to the minimum one second to the maximum 11H 59'59''.
- The alarm rings for 10 to 20 seconds at the time-up moment. The original set time is displayed as soon as the alarm ring ceases to be kept as it is. The alarm ring can be stopped any time with push of any button.

(1) Push button operation of timer

- The following five modes are shown in the timer display.

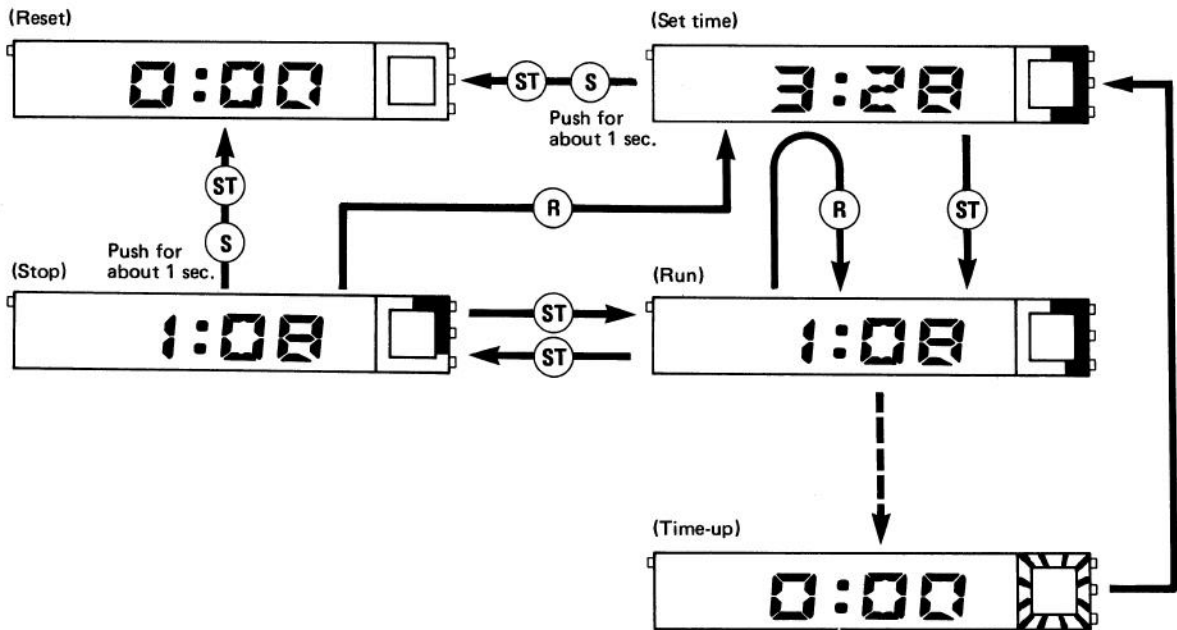

(2) Setting of timer:

- The correction is done individually for each digit through the subtracting method.
- Never fail to secure the displays of "set time", "stop" and "reset" each before setting the timer.
- The digit to be corrected is called out with push of (S) button, and then the setting is carried out with push of (R) button.

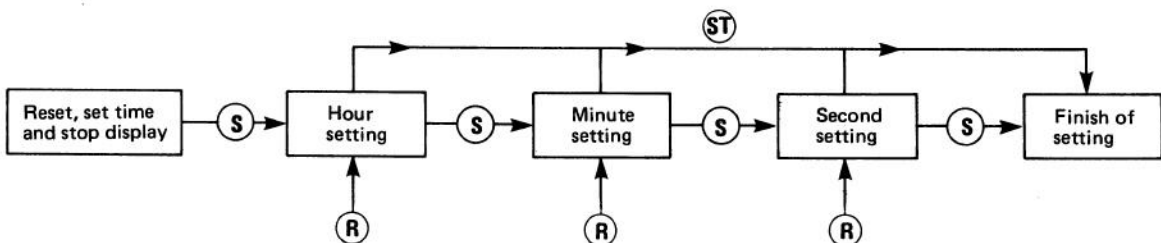

* (S)-button must be pushed for about one second for call-out in the hour setting.

8) Operation of stopwatch

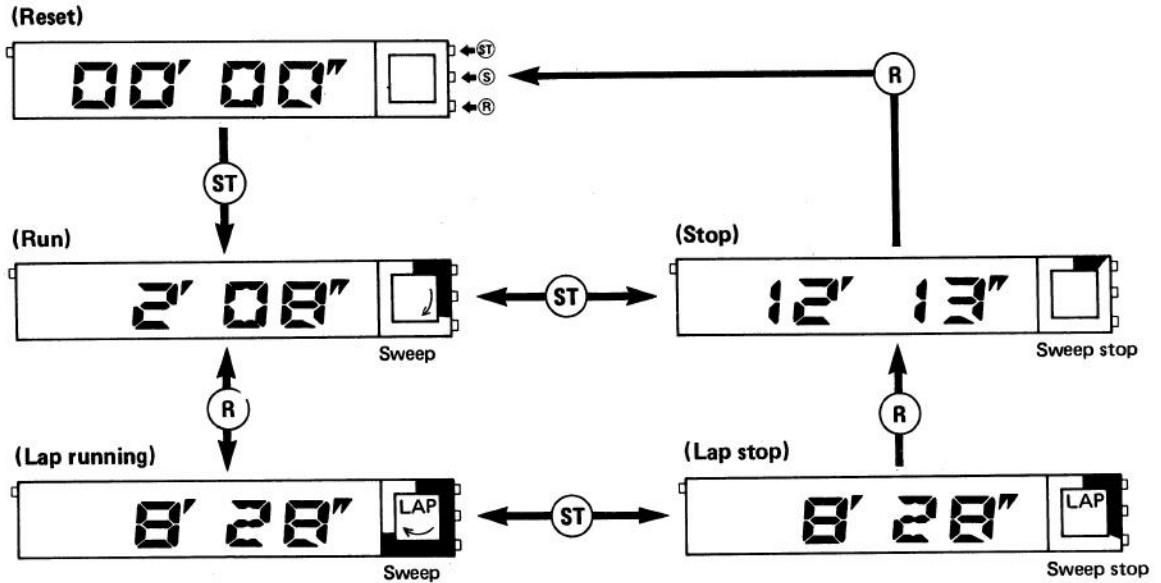

(Call-out of 1/100 sec.)

The "minute/second" display is switched to the "1/100 sec." display while **S** button is pushed and regardless of the "run" or "stop" mode.

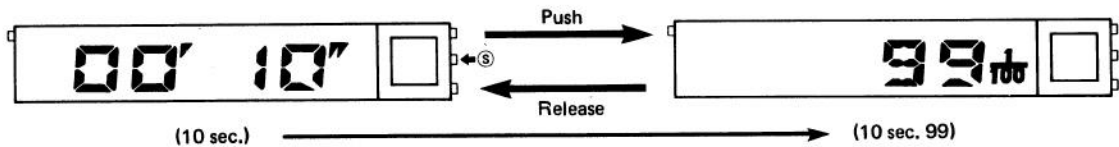

(Sweep display)

The circle segment performs the following displays in the one-second cycle in the mode of "run" ("lap run") and under use of the stopwatch.

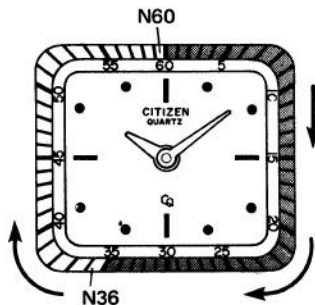

- 1/100 sec ~ 60/100 sec.
Sequent and cumulative glowing is given to the segments from N₁ and every 1/100 sec.
- 60/100 sec. ~ 79/100 sec.
All segments of N₁ ~ N₆₀ glow.
- 80/100 sec. ~ 100/100 sec.
All segments of N₁ ~ N₆₀ are turned out.

The display is discontinued with the cumulating part kept glowing (or turned out) in the mode of the "stop" ("lap stop").

For a count-down action of the timer, the 10-sec. digits are turned off by an amount equivalent to 10 seconds when the 1-sec. circle segment advances by 1 second in the 10-sec. unit (60, 50, 40 . . . 10 seconds) as illustrated right.

