

***TECHNICAL
INFORMATION***

ManualsLib.com

**CITIZEN QUARTZ
Cal. No. 942 ※ ※**

 **CITIZEN**

§ 1. OUTLINE



This is a quartz crystal electronic watch for gentlemen with the liquid crystal display, which has been developed with a view to realizing a big reduction of the cost. It incorporates such multiple functions, in spite of a very compact design, as the alarm function of the glass-vibrating method plus the chime and stopwatch functions. Thus this watch will surely contribute much to develop the new field of the market for the Citizen brands.

ManualsLib.com

§ 2. FEATURES

- 1) The liquid crystal watch for gentlemen developed to realize a big reduction of the cost.
- 2) The trimmer condenser is omitted since the time rate of this caliber is already adjusted enough at the factory. Thus no adjustment is generally given to the time rate at the market.
- 3) Digital Frequency Control (DFC)
The DFC method is adapted to this caliber, and thus the measurement unit time (MEASURE TIME) must be set to "10 sec." or its integer-fold value for measurement of the time rate. This is due to the fact that the frequency is corrected within the circuit every 10 seconds. And no correct measurements is obtained with the unit time "2 sec."
- 4) The power cell life of over 5 years
The non-stop operation of over 5 years is attained for the digital watch thanks to the low power consumption of both the circuit and the liquid crystal (LC) display panel as well as application of the lithium cell.

§3. SPECIFICATIONS

Caliber No.	9420A-00
Module	Outer dia. 28.0 mmφ Thickness 5.65 mm (Power cell part 6.05 mm)
Frequency	32,768 Hz
Accuracy	±15 sec./month at normal temperatures
Digital display part	<ul style="list-style-type: none"> ●FE twist nematic liquid crystal ●2-division multiplex driving ●Normal time display <ul style="list-style-type: none"> – Hour, minute, second and AM/PM ●Display with button operation <ul style="list-style-type: none"> – Month, date and day ●Display with switching operation <ul style="list-style-type: none"> – Alarm function ●Display with switching operation <ul style="list-style-type: none"> – Chime function ●Display with switching operation <ul style="list-style-type: none"> – Stopwatch function <p style="margin-left: 40px;">a) Minute, second and 1/100 sec. (0:00'00" ~ 11:59'59")</p> <p style="margin-left: 40px;">b) Hour, minute and second (0:20'00" ~ 11:59'59")</p>
Integrated circuit	C/MOS-LSI
Effective temperature range	±0°C ~ +60°C (32°F ~ 140°F)
Additional functions	<ul style="list-style-type: none"> ●Illumination lamp ●Fully automatic calendar (incl. leap years) ●Alarm monitor ●Function marks
Power cell (lithium cell)	Parts No. : 280-201 Manufacturer No. : BR2320 Nominal voltage : 3V Size : 23.0φ x 2.0 mm Capacity : 100 mAh Life time : 5 years or more

§ 4. HANDLING INSTRUCTIONS (The flashing areas are shown in the red color)

1) Push-buttons and functions



12:38'28" AM (Alarm ON, Chime ON)

2) Mode switching

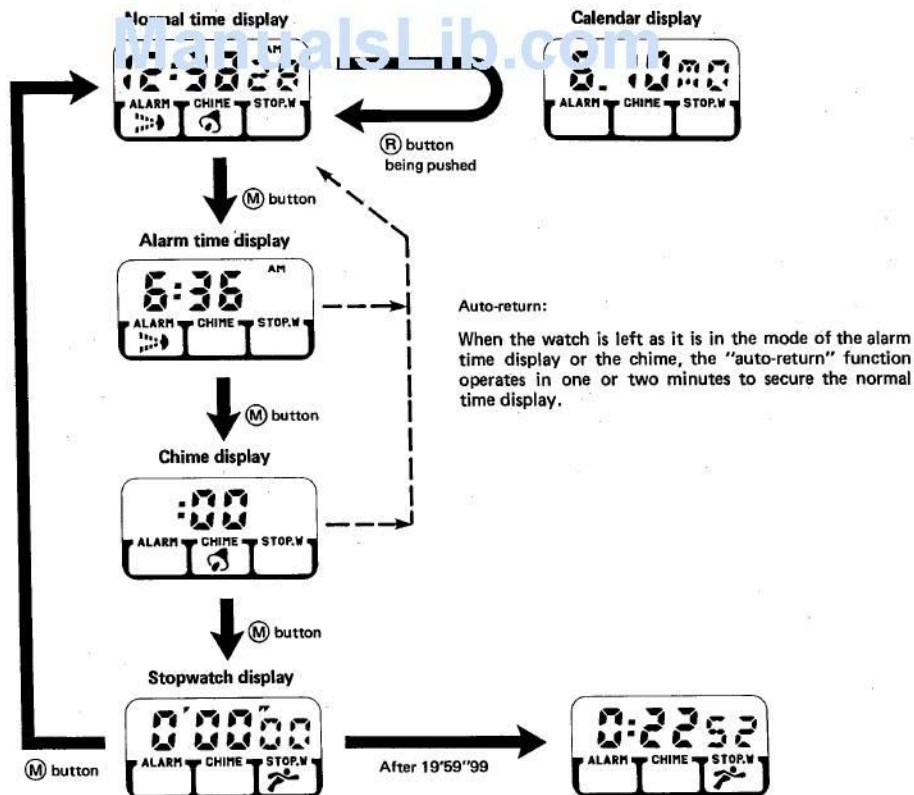

3) Time setting

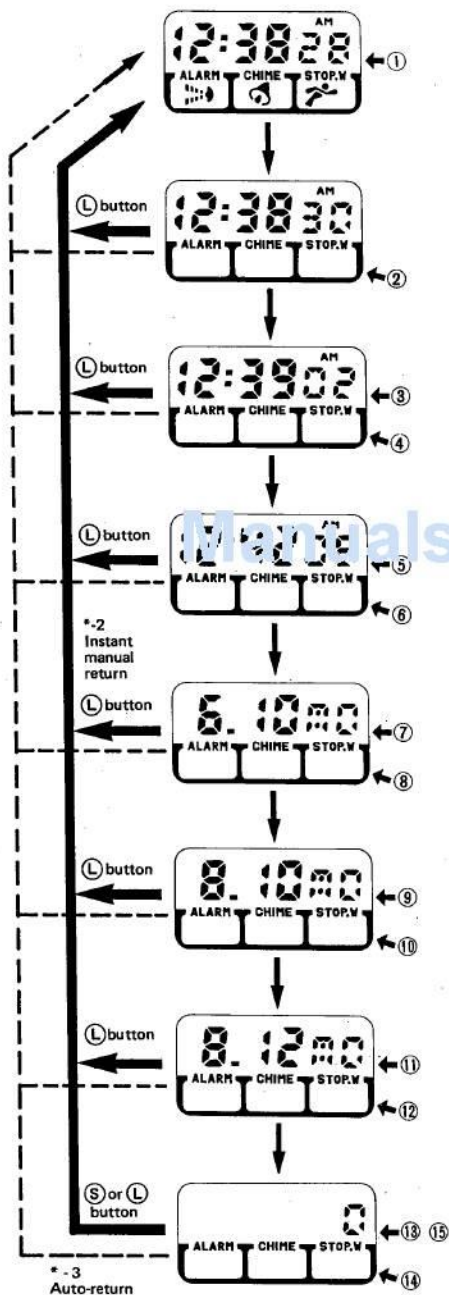
**Normal time display**

- ① With push of **S** button about two seconds in the mode of the normal time display, the second has flashing.

Setting of second

- ② With push of **R** button, the "second" resets to zero when the "second" reads 00 ~ 29. While in case the "second" reads 30 ~ 59, the "minute" is carried by one.

Setting of minute

- ③ With push of **S** button in the mode of the "second" setting, the "minute" has flashing.
④ The "minute" is set with push of **R** button.

Setting of hour

- ⑤ With push of **S** button in the mode of the "minute" setting, the "hour" plus "AM/PM" have flashing.
⑥ The "hour" is set with push of **R** button, making sure of AM or PM.

Setting of month

- ⑦ With push of **S** button in the mode of the "hour" setting, the "month" has flashing.
⑧ The "month" is set with push of **R** button.

Setting of date

- ⑨ With push of **S** button in the mode of the "month" setting, the "date" has flashing.
⑩ The "date" is set with push of **R** button.

Setting of day

- ⑪ With push of **S** button in the mode of the "date" setting, the "day" has flashing.
⑫ The "day" is set with push of **R** button.

Setting of year *-1

- ⑬ With push of **S** button in the mode of the "day" setting, the "year mark" is displayed.
⑭ The "year" is set with push of **R** button.
⑮ With the second push of **S** button, the display is reset to the normal time.

***-1 Setting of year**

The year divisible by 4 is set to 0. Thus the "year mark" is set to 0 for 1980 since if the year can be divided by 4. The "year mark" varies in the order of 0, 1, 2, 3, 0, 1 and so on.

***-2 Instant manual return**

In the time setting, the setting modes change usually in that order of "Second → Minute → Hour → Month → Date → Day → Year". However, the normal time display, if desired, can be reset instantly with push of (L) button in any one of the setting modes mentioned above.

***-3 Auto-return**

When the watch is left as it is in any one of the setting modes, the "auto-return" function operates to reset the normal time display automatically in one or two minutes.

4) Function of alarm

The normal time display is changed to the alarm time display with push of (M) button. The ON and OFF of the alarm function are switched by pushing (R) button.

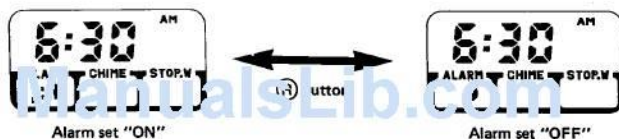
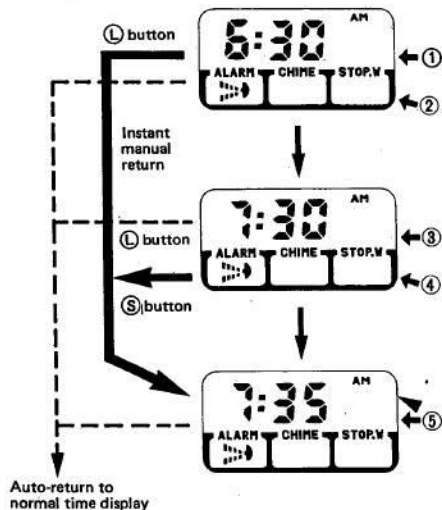
**Setting of alarm time****Setting of alarm "hour"**

- ① With push of (S) button about 2 seconds in the mode of the alarm time display, the "hour" plus "AM/PM" have flashing.
- ② The "hour" is set with push of (R) button, making sure the AM or PM.

Setting of alarm "minute"

- ③ With push of (S) button in the mode of the "hour" setting, the "minute" has flashing.
- ④ The "minute" is set with push of (R) button.

Alarm time display

- ⑤ With the second push of (S) button, the flashing of "minute" ceases. And the alarm time display is secured.

• Ringing way of alarm

The alarm rings at the set time in the short duration and in 8 times per second for 30 seconds.

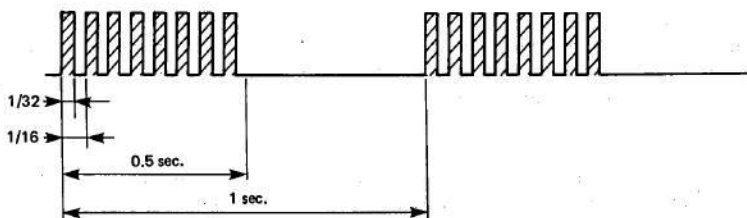

- (1) The alarm ring can be stopped at any time by pushing any one of the push-buttons.
- (2) When the alarm is set, the  mark is displayed when the normal time display is reset in order to indicate the alarm being set.

5) Function of chime

The chime display is  when the push of  in the mode of the alarm time display.

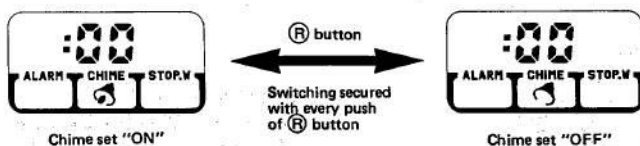

• Ringing way of chime

The short duration of sound rings twice every hour on the hour after the chime is set ON.

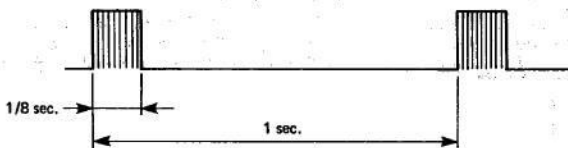

After the chime is set ON, the  mark is displayed when the normal time display is reset to indicate the chime being set.

6) Function of stopwatch

The chime display is switched to the stopwatch display with push of (M) button.

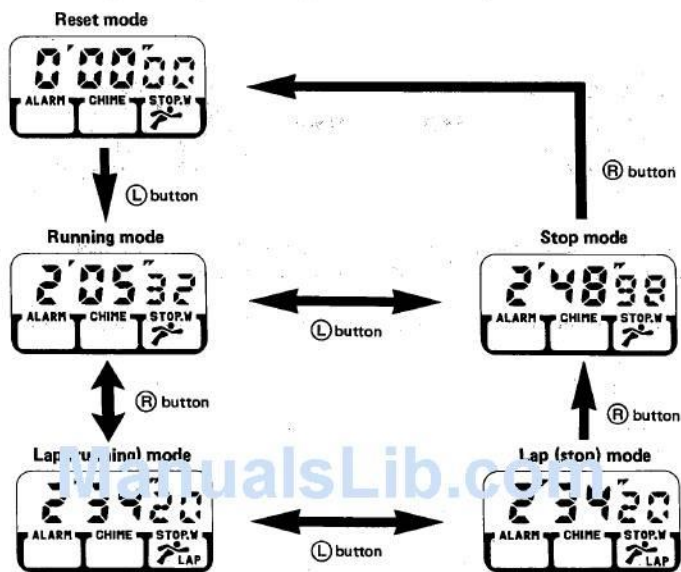

One of the five modes shown above is given under the stopwatch display. The operation of the stopwatch function starts by securing the present mode via the operation of (L) and (R) button as follows.

1 Reset mode

The 0'00'00 is displayed to indicate the preparatory state for measurement of the time. With push of (L) button then, the running mode is secured.

2 Running mode

This mode shows that the time is being measured with flashing of ' ' mark.

3 Stop mode

The ' ' mark ceases flashing to indicate that the time measurement is discontinued. With push of (R) button under these conditions, the reset mode is secured again.

4 Lap (running) mode

In this mode the part-way time can be obtained under the running mode. The display is discontinued but the time measurement is continued yet. With push of (R) button then, the running mode is reset again. And with push of (L) button, the time measurement is stopped. The ' ' mark is still flashing.



5 Lap (stop) mode

In this mode the 1st and 2nd place time can be obtained. With push (L) button in the lap (running) mode, the lap (stop) mode is secured. And with push of (R) button then, the lap (stop) mode is switched to the stop mode. However, the time value accumulated from the run mode is under display.

(1) Change of display

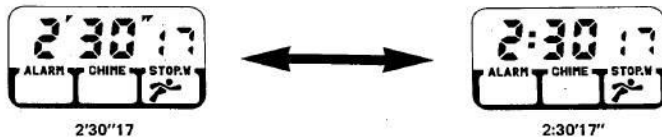

The "minute, second and 1/100 sec." are displayed with the stopwatch display from 00000 to 9999. But the "hour, minute and second" are displayed during the time from 0:2000 to 1:5999.

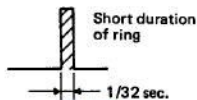

- (2) In the running and lap (running) modes of the stopwatch, the  mark is displayed when the normal time display is reset to indicate the time being measured.
- (3) With push of  button, the confirmation tone is heard in a short duration with every start/stop.



Alarm monitor

The alarm tone is produced with simultaneous push of  and  buttons in the mode of the normal time display or the calendar display. This alarm tone features a long and continuous duration as long as the both buttons are pushed.



*Note on replacement of power cell:

When the power cell is replaced with the new one, the non-existing figure may sometimes be displayed. In such case, the four push-buttons are pushed all at the same time to secure the normal display. After this, the time setting is carried out.

§5. CIRCUIT DIAGRAM

The circuit structure of this caliber is identical to that of Cal. No. 9460A, which is previously marketed, and with addition of the alarm function.

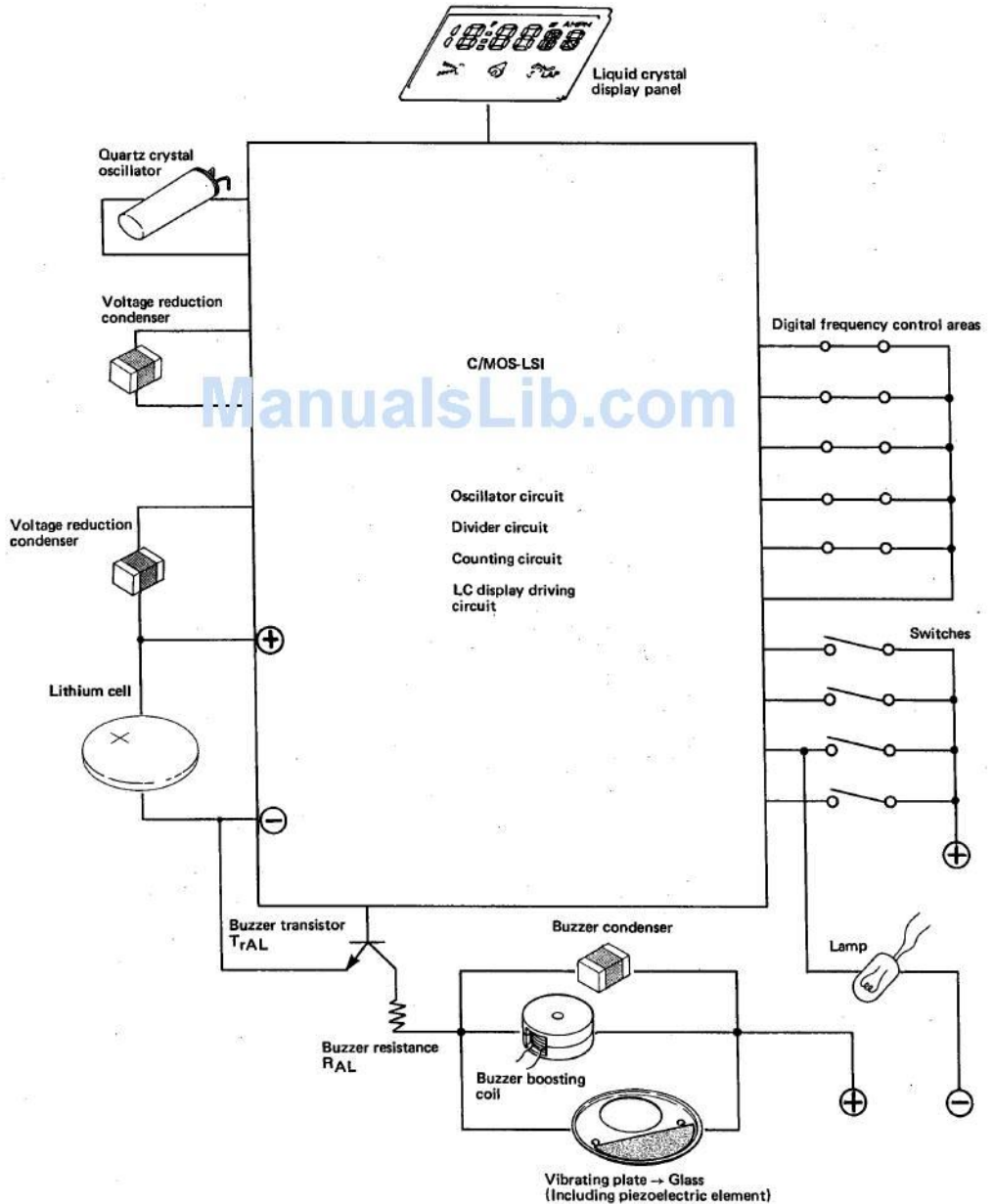

§ 6. DISASSEMBLY/ASSEMBLY OF MODULE

Disassembling procedure: ① ~ ⑩

Assembling procedure: ⑩ ~ ①

1) Power cell side

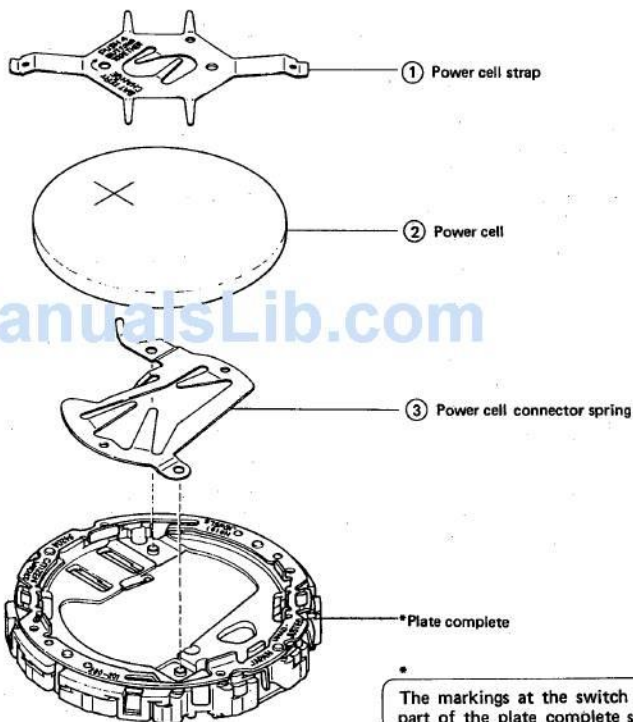

* The markings at the switch holder part of the plate complete such as the caliber No., JAPAN and the like may sometimes be at the reverse position since the switch holder features a symmetric form.

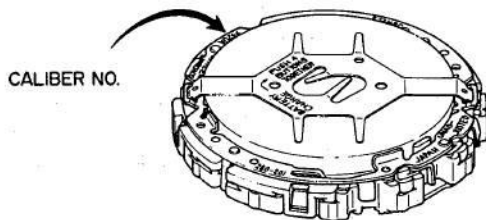

● Handling of LC display panel holder

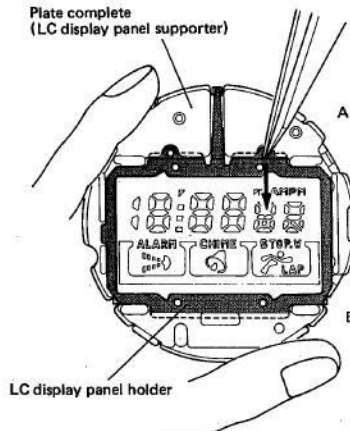

The LC display panel holder is fixed under the LC display panel supporter at both A and B sides. When disassembling, as illustrated left, the tweezers is put into the hole of the LC display panel holder to be then pressed toward the arrow. Thus the LC display panel holder is removed first (at two areas in the A direction).

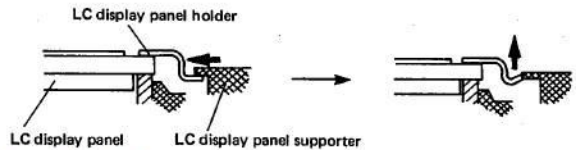

ManualsLib.com

When incorporating the LC display panel holder, the fact must be made sure that the LC display panel is set steady on the LC display panel connection rubber. And then the A side is put under the LC display panel supporter via the tweezers after the B side. Be careful not to give flaws or the break to the LC display panel.

Notes on Disassembling and Assembling

• Handling of power cell strap

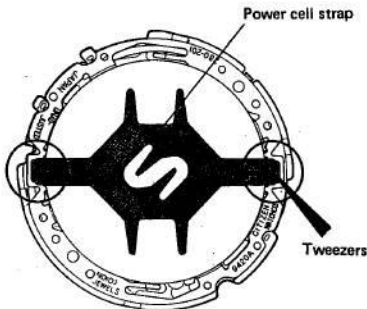

As shown in the left diagram, the power cell strap is removed by pressing one of the two hooking parts toward the center area and then lifting up slightly by means of the tweezers or the like.

With this caliber, it may be possible very rarely that no oscillation is secured when the power cell is replaced. In such case, the connection is given via the tweezers or the like to the L button or its corresponding contact area of the module.

The reason of the above: the application of the power is usually detected within the IC, and at the same time the pulse is produced to apply 3V to the oscillator circuit for the fixed time. However, the 3V may not sometimes be applied to the oscillator circuit due to the fact that the time of pulse generation is too short.

In such case, the push of L button can substitute for the direct application of 3V to the oscillator circuit. Thus the starting is secured for oscillation.

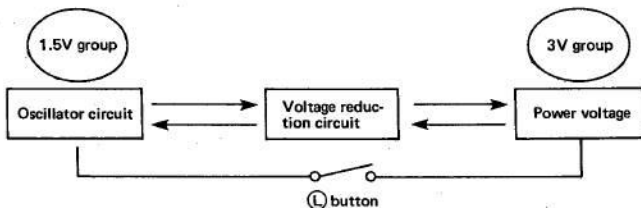

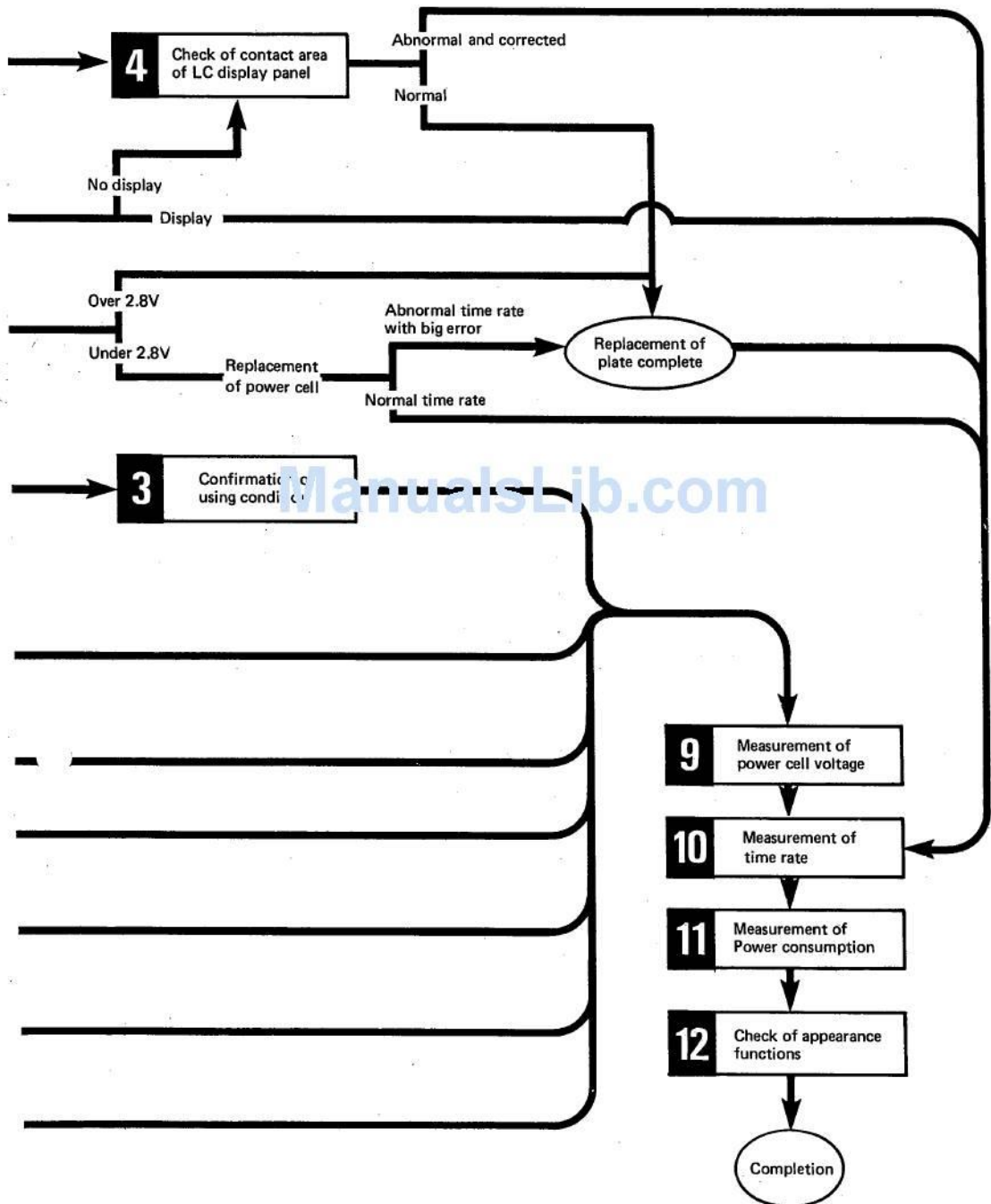

§ 7. TROUBLESHOOTING AND ADJUSTMENT

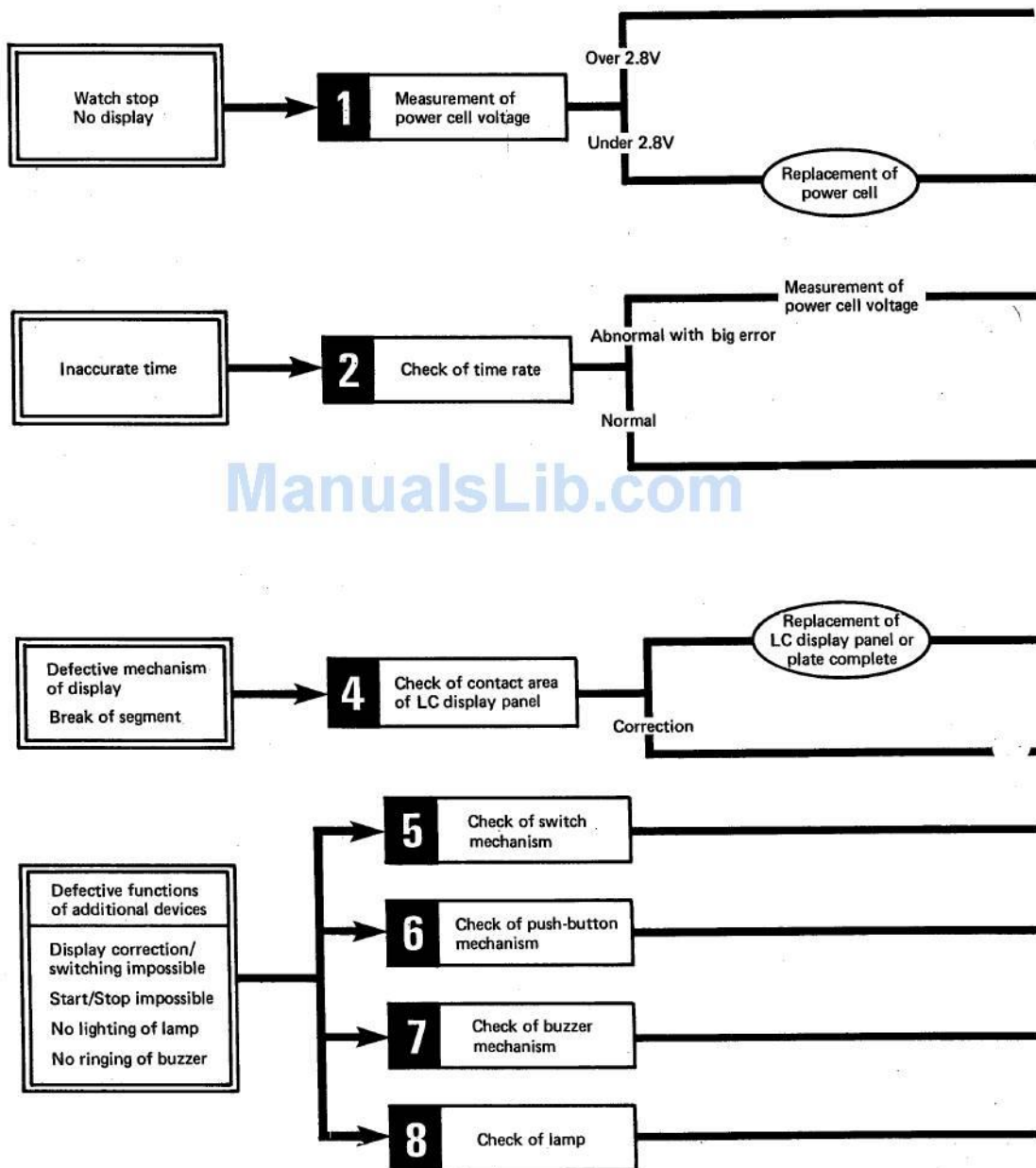

Incorrect time

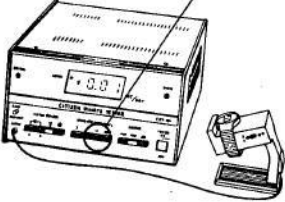
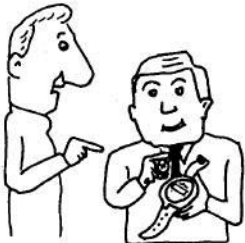
Checking items	How to check	Result and treatment
<p>2 Check of time rate</p>	<p>The measurement unit time must be set to "10 sec." or its integer-fold value. Otherwise the measurement may be erroneous.</p>  <p>This is due to the fact that a signal is emitted every ten seconds within the I.C. to give adjustment to the time rate.</p> <p>In case a big error is detected in the time rate, the plate complete must be replaced with new one.</p>	<p>Big error detected in time rate</p> <p>→ Replacement of plate complete</p> <p>Normal time rate</p> <p>→ 3 Confirmation of using condition</p>
<p>3 Confirmation of using condition</p>	<p>The following points must be confirmed in case the time is inaccurate although no fault is detected through checking of the time rate, along with a measurement test.</p> <ol style="list-style-type: none"> 1. Whether some misoperation has been given to the watch. 2. Whether the watch has been used at an extremely high or low temperature. 3. How many days have passed since the time adjustment was given last. 	

Watch stop – No display at all

Checking items

How to check

Result and treatment

- 1 Measurement of power cell voltage

The measurement must be carried out with the power cell incorporated into the watch.

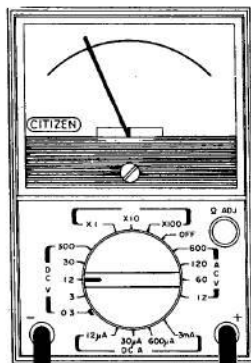

Under 2.8V

→ Replacement of power cell

Over 2.8V

→ 4 Check of contact area of LC display panel

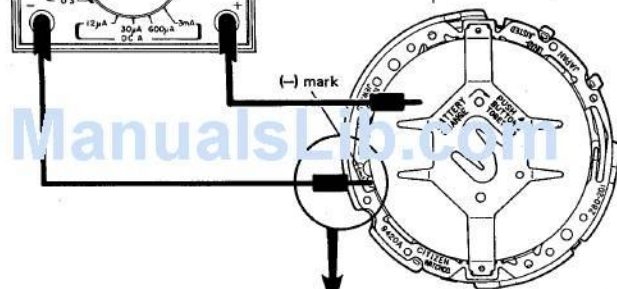

The minus lead of the tester must be applied perfectly to the minus terminal. If the short-circuit is caused between the minus lead and other areas, the voltage will drop.

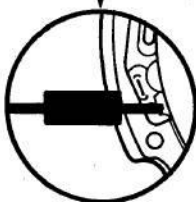

Notice that the voltage drops temporarily if the lamp or the alarm is actuated before measurement of the power cell. The voltage also drops in case the short circuit is caused between the minus terminal and the power cell or other metal parts.

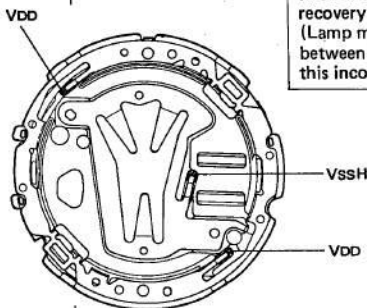

In such cases, the time of more than 5 minutes is required to secure recovery of the voltage for the second measurement.

(Lamp may be turned off continuously if the short-circuit is caused between the minus terminal and other metal area (V_{DD}). To solve this inconvenience, the lamp is turned on.)



In case no display is given although the power cell shows the normal voltage, the complete contact must be secured between the spring tip and the pattern of the plate complete. (See the upper diagram.)

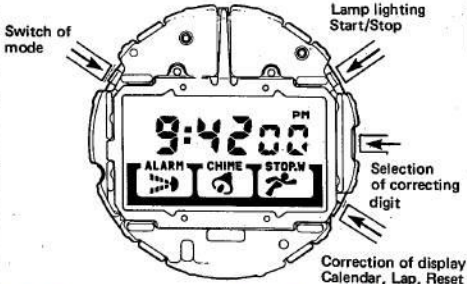

Incomplete functioning of additional mechanisms — Display correction impossible

Checking items	How to check	Result and treatment
5 Check of switch mechanism	<p>As illustrated below, each switch area is pressed with the tweezers or the like in order to check the correct operation for each function.</p> <p>At the same time, check whether an extreme malformation is caused on the surface of the switch button where the push-button has a contact</p> 	<p>Normal operation</p> <p>→ Check of push-buttons</p> <p>Defective operation</p> <p>→ Check of switch springs</p> <p>Break or malformation of switch spring</p> <p>→ Replacement of plate complete</p>
6 Check of push-buttons mechanism	<p>It is beneficial to confirm the degree of stroke with the module put into the case and prior to checking of the push-buttons.</p> <ol style="list-style-type: none"> 1. Each push-button is detached from the case to examine whether it has some malformation. 2. The dust or stains sticking to the push-buttons themselves as well as the areas of the case where the buttons are set in must be cleared away completely. 3. Never fail to apply the silicone oil to each push-button. 	

Application List of Push-buttons

	Normal time display	Alarm time display	Chime display	Stopwatch display
M button	Mode switching	Mode switching	Mode switching	Mode switching
L button	Light Instant manual return	Light Instant manual return	Light	Start/Stop Light
S button	Selection of digits	Selection of correction digit for alarm time	—	—
R button	Calendar display	Alarm time correction Alarm set ON/OFF	Chime set ON/OFF	Zero-reset of stopwatch Lap and lap release

Incomplete functioning of display mechanism – Partial break of segment

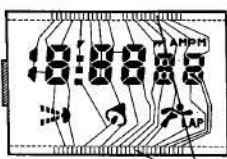
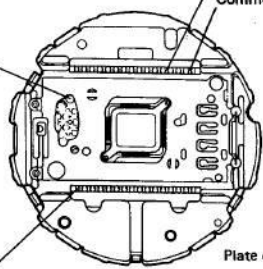
Checking items	How to check	Result and treatment
<p>4</p> <p>Check of contact part of LC display panel</p>	<p>1. Check of LC display panel holder</p> <ol style="list-style-type: none"> 1) Whether the LC display panel holder has some malformation. 2) Whether the LC display panel holder is put perfectly under the LC display panel supporter. 3) Whether some malformation is caused at the area where the LC display panel holder is fixed via the LC display panel supporter.  <p>2. Check of LC display panel connection rubber</p> <ol style="list-style-type: none"> 1) Whether the connection rubber has some twist or deformation. 2) Whether the connection rubber has some dust or dirt on it.  <p>3. Check whether the electrode part of the LC display panel has some dust, dirt or crack. The same checking must be given also to the electrode part of the plate complete.</p>  <p>LC display panel</p> <p>Electrode parts</p> <p>Common B</p>  <p>VDD</p> <p>Common A</p> <p>Plate complete</p>	<p>Malformation of LC display panel holder</p> <p>→ To be replaced</p> <p>Rubber twisted or deformed</p> <p>→ To be replaced</p> <p>Dust or stains</p> <p>→ To be cleared off</p> <p>Dust or stains</p> <p>→ To be cleared off</p> <p>LC display panel cracked</p> <p>→ To be replaced</p> <p>• No defect detected through above checking</p> <p>→ Replacement of LC display panel</p> <p>Correction impossible yet</p> <p>→ Replacement of plate complete</p>

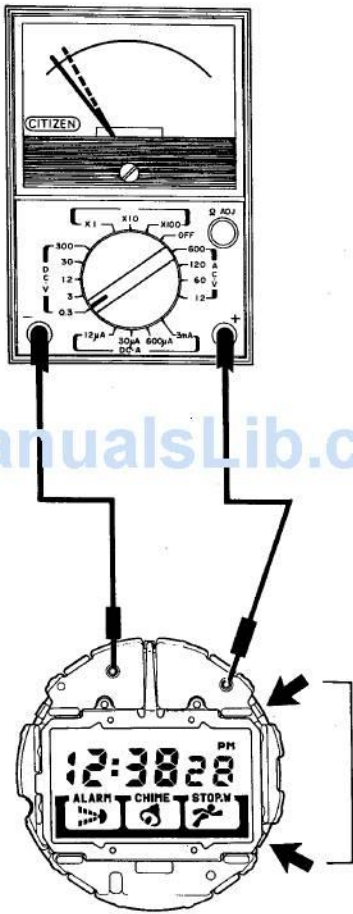
Checking items	How to check	Result and treatment
	 <p>The diagram illustrates the testing procedure. A multimeter is connected to the watch's internal terminals. The watch display shows the time 12:38.28 PM. Two buttons on the watch case are indicated by arrows, with a note: "Push two-buttons simultaneously".</p>	<ul style="list-style-type: none"> • Tester's pointer swinging <ul style="list-style-type: none"> → Normal • No swinging of tester's pointer <ul style="list-style-type: none"> → Replacement of plate complete <p>Push two-buttons simultaneously</p>

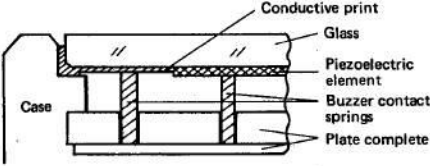
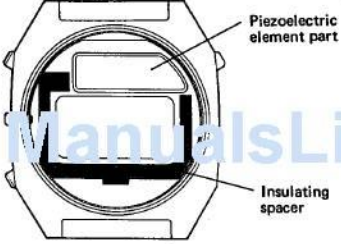
Checking items	How to check	Result and treatment
<p>7 Check of buzzer mechanism</p>	<p>This module uses the piezoelectric element stuck to the glass (appearance parts) to produce the vibration.</p>  <p>As illustrated in the left, one of the two buzzer contact springs is connected to the conductive print part (VDD) with the other connected to the piezoelectric element part from the plate complete each.</p>  <p>As shown in the above diagram, the insulating spacer is put into the position shown in the diagram when assembling. Thus be careful of the direction of the spacer.</p> <p>When the alarm does not ring, the following points must be checked.</p> <ol style="list-style-type: none"> 1. Single unit of glass <ol style="list-style-type: none"> ① Whether the glass itself has some crack or break. ② Whether the piezoelectric element has some crack or break. 2. Buzzer contact spring <ol style="list-style-type: none"> ① Whether the buzzer contact spring has some malformation. <p>If the alarm does not ring yet after finishing the above checking each, the output sent from the plate complete must be checked by the tester as follows. The plus (+) lead of the tester is connected to VDD; while the minus (-) lead is applied to one of the two buzzer contact springs that has a contact to the piezoelectric element. After this, both (L) & (R) buttons are pushed simultaneously (Alarm monitor mode) to give checking to the operation of the tester.</p>	<p>Glass crack or break → Replacement</p> <p>Buzzer contact spring malformation → Replacement</p>

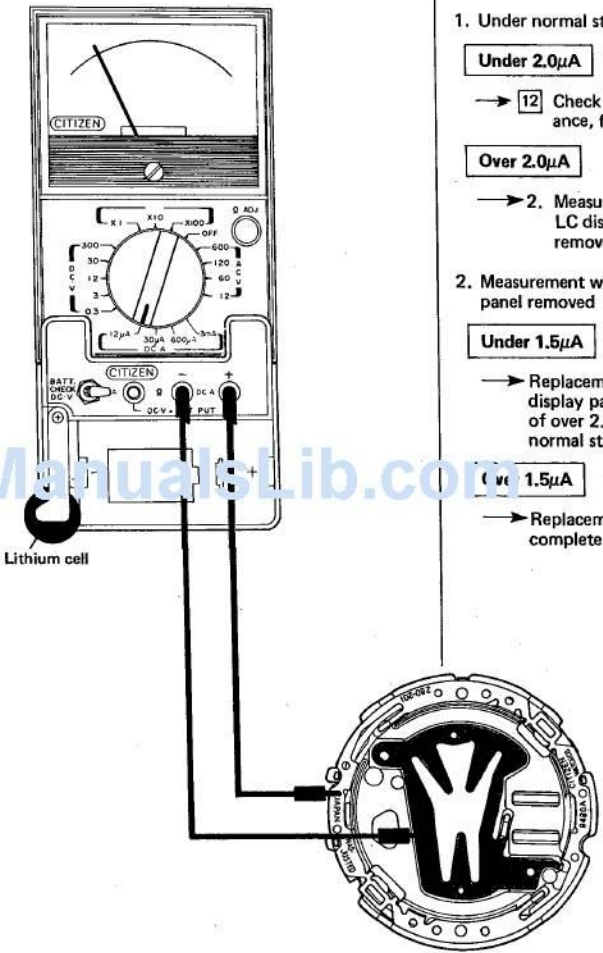
Checking items	How to check	Result and treatment
<p>11 Measurement of power consumption</p>	 <p>The diagram illustrates the setup for measuring power consumption. A CITIZEN multimeter is connected to the terminals of an open watch case. The multimeter's range selector is set to DC A, and the scale is set to 30µA. The watch case is shown with its internal components, including the battery and the display panel. A lithium cell is connected to the watch case terminals.</p>	<ol style="list-style-type: none"> Under normal state <ul style="list-style-type: none"> Under 2.0µA <ul style="list-style-type: none"> → 12 Check of appearance, functions Over 2.0µA <ul style="list-style-type: none"> → 2. Measurement with LC display panel removed Measurement with LC display panel removed <ul style="list-style-type: none"> Under 1.5µA <ul style="list-style-type: none"> → Replacement of LC display panel (in the case of over 2.0µA under normal state) Over 1.5µA <ul style="list-style-type: none"> → Replacement of plate complete

In case the amount of power consumption is large, the inspection must be given also the dust and dirt at the contact part of the LC display panel.

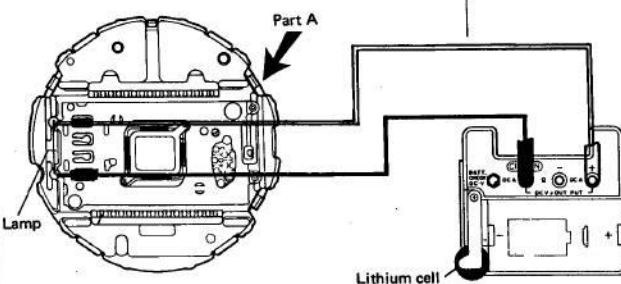
Checking items	How to check	Result and treatment
8 Check of lamp	 <p>As shown in the above diagram, the leads from the OUT PUT terminals of the tester's adaptor are applied across the lamp attached to the plate complete. In this case, no distinction is required for plus (+) and minus (-) polarities.</p>	<ul style="list-style-type: none"> ● Lamp lighting → Checking to be given again to part A ● No lighting of lamp → Replacement of plate complete
9 Measurement of power cell voltage	Refer to 1 .	
10 Measurement of time rate	<p>This module uses no trimmer condenser since the perfect control has already been given to the time rate via the digital circuit in the factory.</p> <p>Accordingly, the plate complete is replaced with new one only in case the timer rate has a big error.</p> <p>Never fail to set the "MEASURE TIME" to 10 sec. or its integer-fold value when measuring the time rate.</p>	

Checking items	How to check	Result and treatment
12 Check of appearance, functions	<p>The following points are checked with the finished watch.</p> <ol style="list-style-type: none"> Whether the Alarm monitor function operates correctly with the simultaneous push of both (L) and (R) buttons and with the proper volume of ringing. Whether each push-button has a smooth operation. (Refer to the "Application List of Push-buttons" in [6].) The LC display screen must be free from any dust or stains. With simultaneous push of all four buttons (M), (L), (S) and (R) the "all-reset" function operates in the module circuit to give the following displays. <div style="text-align: center;">  </div> <ul style="list-style-type: none"> • Time 12:0000 • Calendar 1. 150 (Year mark) 0 • Alarm 12:00 Alarm set OFF • Chime :00 Chime set OFF • Stopwatch 0:0000 Reset mode 	

ManualsLib.com
CITIZEN WATCH CO., LTD.
Tokyo, Japan