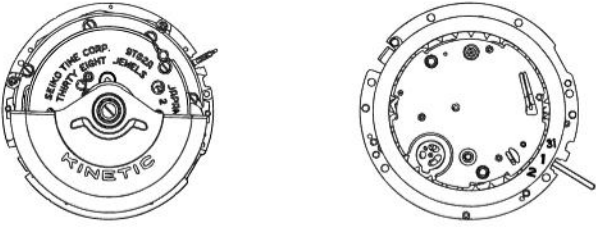

PARTS CATALOGUE/TECHNICAL GUIDE

Cal. 9T82A

(For Movement Replacement)

[SPECIFICATIONS]

Item		Cal. No.	9T82A
Movement			
Movement size	Outside diameter		ø33.0 mm
	Casing diameter		ø30.0 mm
	Height		6.8 mm
Time indication			<ul style="list-style-type: none"> • Time: Hour, minute and second hands • Stopwatch: Stopwatch hour, minute, second and 1/10 second hands
Driving system			Step motor (Load compensated driving pulse type)
Additional mechanism			<ul style="list-style-type: none"> • Automatic generating system • Stopwatch function with stopwatch hour, minute, second and 1/10 second hands • Overcharge prevention function • Energy depletion forewarning function • Electronic circuit reset switch • Train wheel setting device • Date calendar • Instant setting device for date calendar • Instant date change mechanism
Loss/gain			Monthly rate at normal temperature range: less than 15 seconds
Regulation system			Logical regulation system
Measuring gate by quartz tester			Use 10-second gate.
Power supply	Power generator		Automatic generating system
	Electricity Storage Unit (E.S. Unit)		Titanium lithium ion rechargeable battery
Operating voltage range			0.45 V ~ 2.2 V
Duration of charge			From full charge to stoppage: Approx. 1 month (when the stopwatch is used for less than 3 hours a day)
Jewels			38 jewels



PARTS CATALOGUE

Cal. 9T82A

Disassembling procedures Figs. : ① → ⑫

Reassembling procedures Figs. : ⑫ → ①

Lubricating: Types of oil

-  SEIKO Watch Oil S-6
-  Silicone oil 500,000 c.s.
-  Adhesive (LOCTITE 241)

Oil quantity

-  Normal quantity

Conventional type

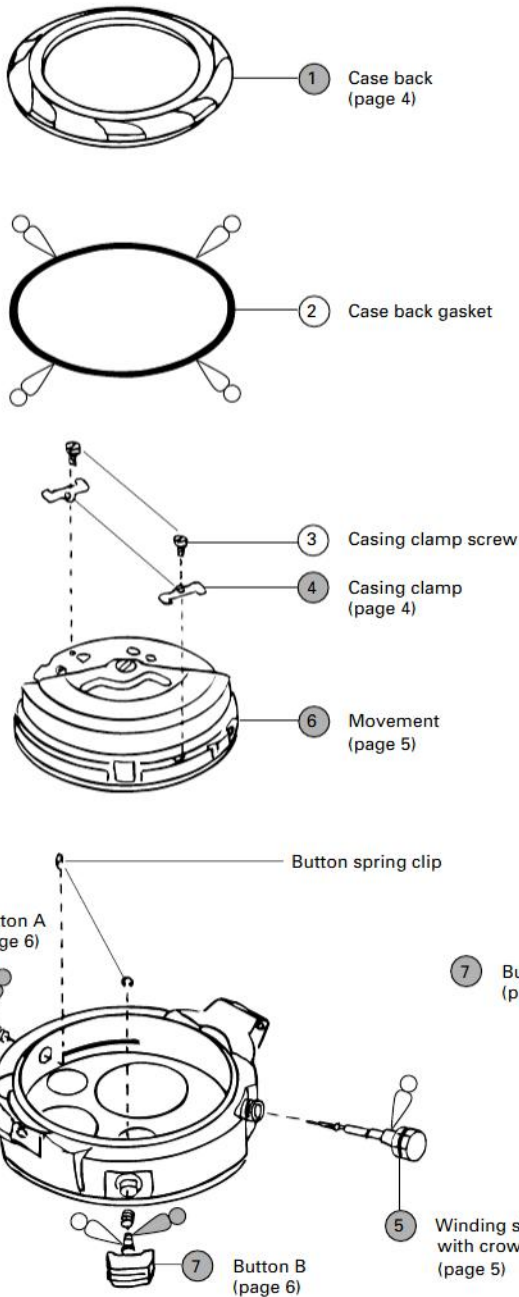

One-piece case type

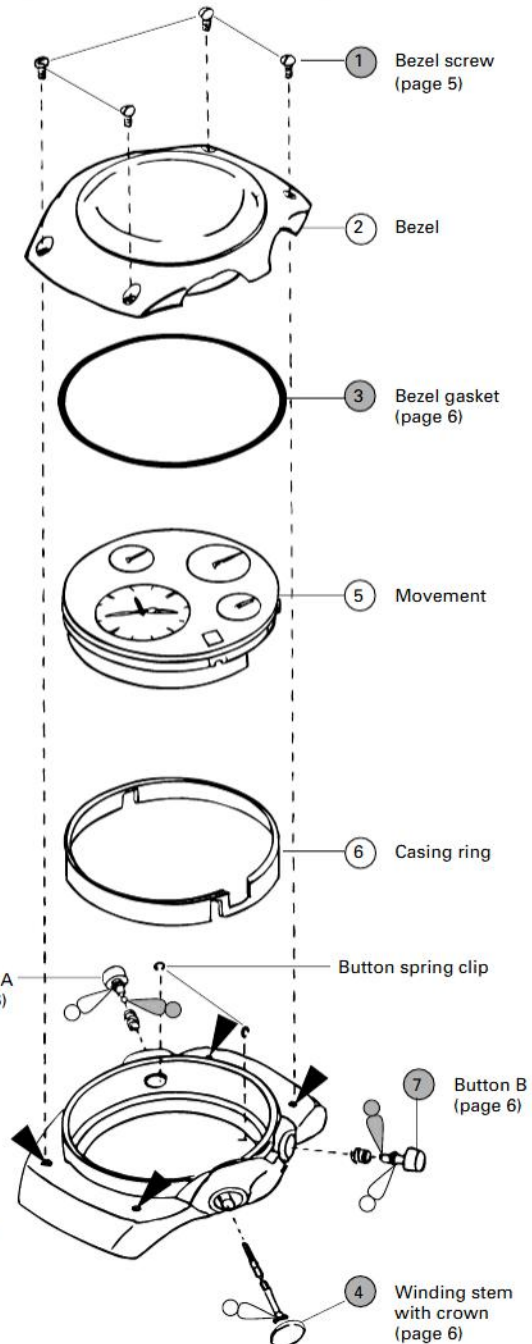

  Please see the page shown after the part name.

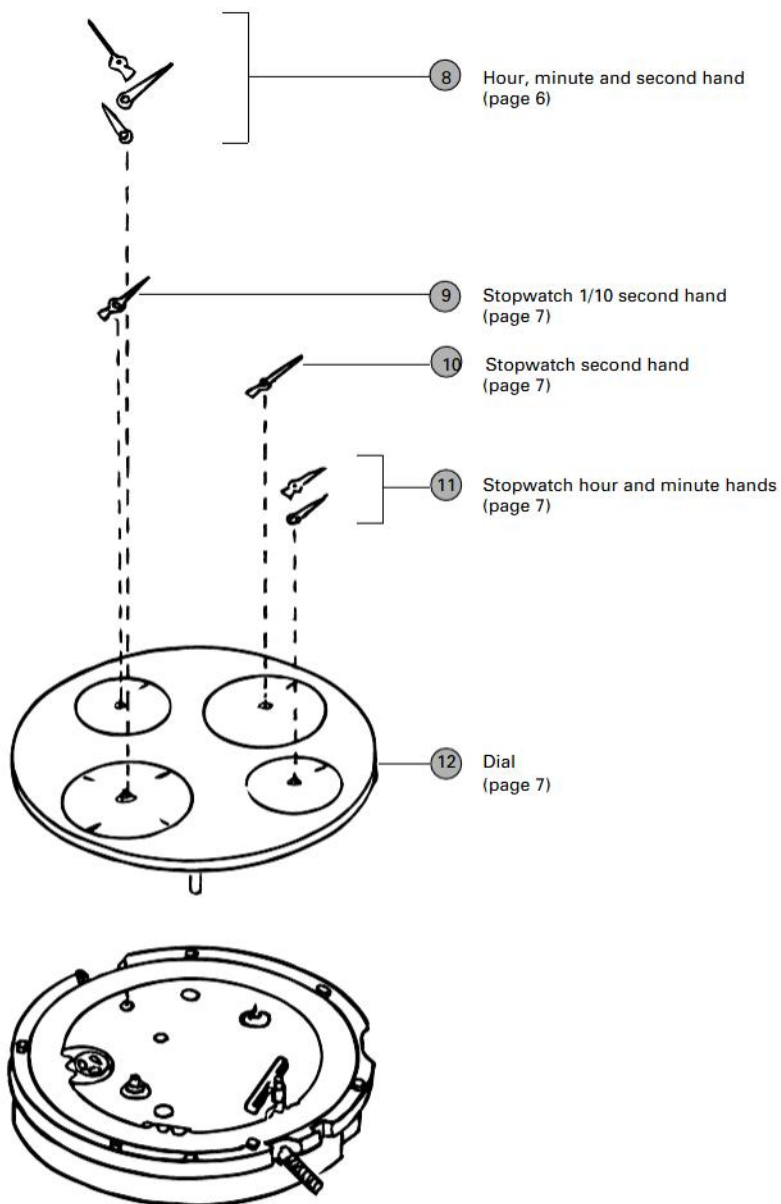

* When reassembling the watch, be sure to use a new set of stopwatch hands.
If the old stopwatch hands are reused, they may come off from the shock when they are reset to "0" position.

● ⇨ Please see the page shown after the part name.

I. REMARKS ON DISASSEMBLING AND REASSEMBLING

For conventional type

① Case back

- To fix the case back to the case, the case back itself is screwed into the case, or the case back screws are used, depending on models.
- For the models using the case back screws, use the adhesive "LOCTITE 241" to prevent them from loosening.

Note: Never use an adhesive other than "LOCTITE 241" for fixing the case back screws.

• How to fix the case back with the case back screws and the adhesive

1. Wipe any adhesive, oil, dust or dirt off the screws and the holes for screws on the case with alcohol.
2. Before setting the case back to the case, apply a proper amount of the adhesive to the holes for screws as shown at right.
3. Set the case back to the case and then, tighten the case back screws firmly.
 - * Tighten the screws one by one in diagonal direction.
 - * After tightening once, give the screws another turn to fix them securely.
4. Leave the watch untouched at room temperature for about one day until the adhesive is completely hardened.

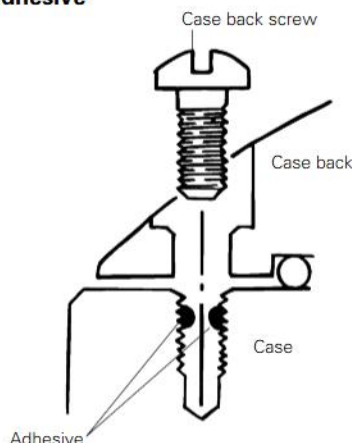

Notes:

- * Apply only a necessary amount of adhesive to the hole lest it should come out on the case.
- * Take care not to let the adhesive stick to the inner surface of the case.

④ Casing clamp

• How to remove

Loosen the casing clamp screws at the 3 and 9 o'clock sides and remove the casing clamps.

• How to install

Set the casing clamps at the 3 and 9 o'clock positions as shown in the illustrations at right, and tighten the casing clamp screws securely.

Note: The movement is fixed to the case by fitting "A" and "B" portions of the casing clamp securely in the groove of the case. When setting the casing clamp to the movement, therefore, check that "A" and "B" portions are equally protruded from the movement edge, and then, tighten the casing clamp screw firmly.

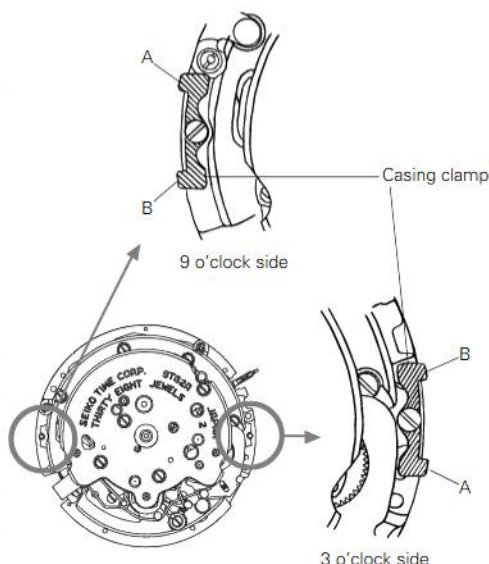

⑤ Winding stem with crown

The crown gasket is attached inside the stem pipe of the case.

• **Lubricating**

Apply the silicone oil to the portion of the crown as indicated in the illustration at right. Insert the winding stem into the stem pipe, and turn the crown so that the silicone oil is spread thoroughly over the crown gasket.

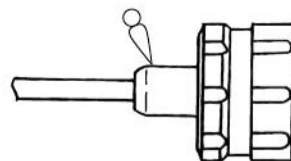

⑥ Movement

When installing the movement into the case, first set its 12 o'clock side to the case and then, other sides. Otherwise, the movement may not be fitted in smoothly.

For one-piece case type

① Bezel screw

• **Remarks on the adhesive**

- An adhesive is used to fix the bezel screws.
- Be sure to use the adhesive "LOCTITE 241" to fix the bezel screws.

Note: Never use an adhesive other than "LOCTITE 241" for fixing the bezel screws.

• **How to fix the bezel screws with the adhesive**

1. Wipe any adhesive, oil, dust or dirt off the screws and the holes for screws on the case with alcohol.
2. Before setting the bezel to the case, apply a proper amount of the adhesive to the holes for screws as shown at right.
3. Set the bezel to the case and then, tighten the bezel screws firmly.
 - * Tighten the screws one by one in diagonal direction.
 - * After tightening once, give the screws another turn to fix them securely.
4. Leave the watch untouched at room temperature for about one day until the adhesive is completely hardened.

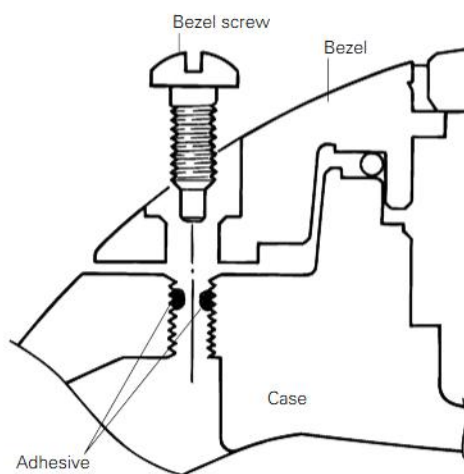

Notes:

- * When tightening the bezel screws, use a screwdriver having a flattened tip of a size corresponding to that of the screws. Take care not to damage the slots of the bezel screws, bezel or case.
- * Apply only a necessary amount of adhesive to the hole lest it should come out on the case.
- * Take care not to let the adhesive stick to the inner surface of the case.

③ Bezel gasket

Never apply the silicone oil to the bezel gasket. Otherwise, the silicone oil may spread to the dial or other parts, causing malfunctions.

④ Winding stem with crown

• **How to remove**

Push the lever for unlocking stem between the dial and the case vertically down with tweezers, and remove the winding stem with crown.

For both types

⑦ Buttons

• **Lubricating**

Apply SEIKO Watch Oil S-6 to the end portions of the buttons that touch the lever.

⑧ Hour, minute and second hands

• **How to install the hour hand**

The watch is provided with the instant date change mechanism. In order for the date to change at the exact time, install the hands following the procedure below.

1. Slowly turn the crown counterclockwise. Stop turning the crown when the date has changed.
2. Install the hour hand so that it points slightly ahead of the 12 o'clock marker (See the illustration at right).
3. Install the minute and second hands so that they point exactly to the center of the 12 o'clock marker.

Notes:

- * Check clearance among the hands at the 12, 3, 6 and 9 o'clock positions lest they should touch one another.
- * Some models have hands coated with LumiBrite. When handling the hands, therefore, take care not to damage the LumiBrite coating.

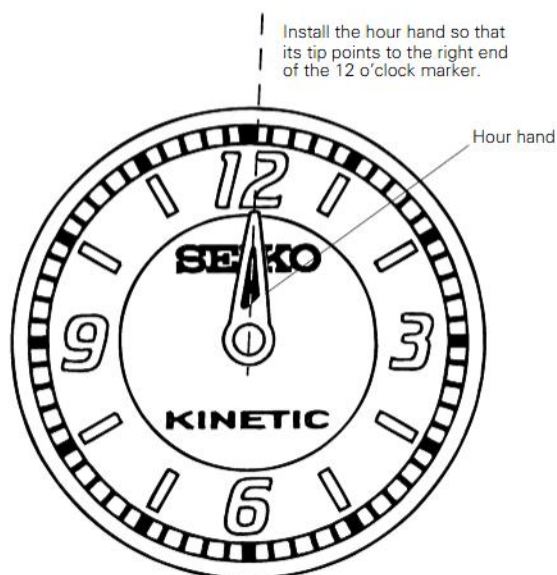

- ⑨ Stopwatch 1/10 second hand
- ⑩ Stopwatch second hand
- ⑪ Stopwatch hour and minute hands

* When reassembling the watch, be sure to use a new set of stopwatch hands.

If the old stopwatch hands are reused, they may come off from the shock when they are reset to "0" position.

• **How to install**

1. Reset the stopwatch to "00".

When the stopwatch is properly reset to "00", the hammer appears in the eyehole "A" as shown below.

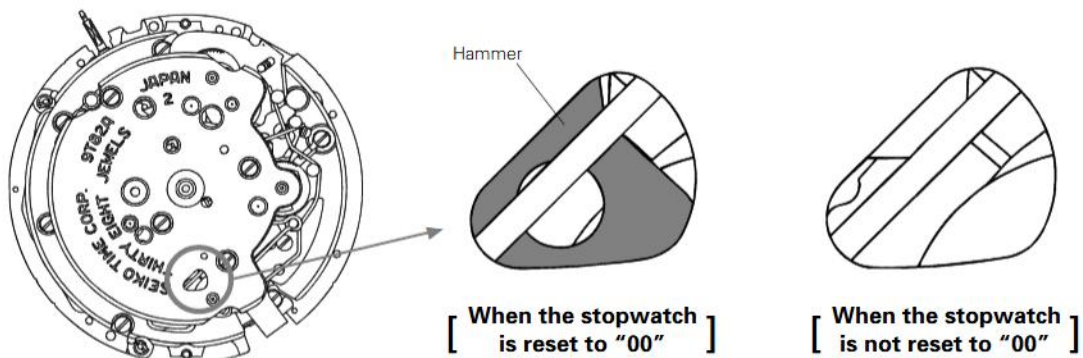

2. Set all the stopwatch hands accurately to the 12 o'clock position, and push them in completely.

Notes:

- * Push in the hand securely until the lower end of the hand installing pipe ("A" in the illustration) reaches below the "D"-shaped notch of the arbor.
- * Check that the stopwatch hour and minute hands do not touch each other.

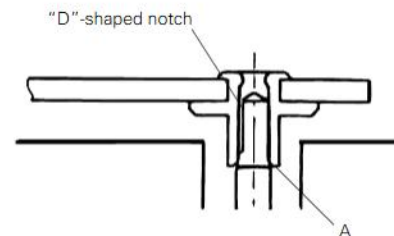

- ⑫ Dial

The dial is fitted to the movement by fixing the two dial legs with the eccentric posts.

• **How to remove**

Turn the eccentric posts counterclockwise to release the dial legs, and remove the dial.

• **How to install**

Set the dial in position. While pressing down the dial at the 12 o'clock side so that the dial is well-seated on the movement, turn the eccentric posts clockwise to fix the two dial legs.

Note: If metal chips are generated from the eccentric posts, be sure to remove them.

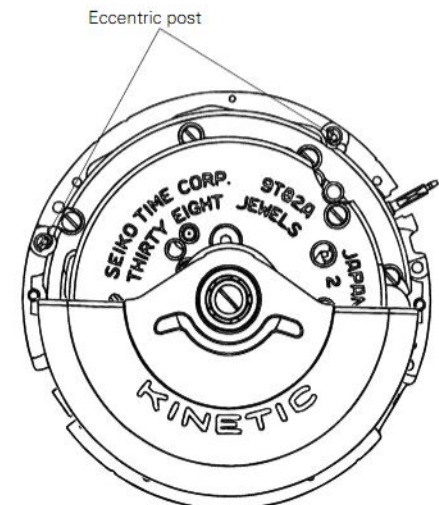

II. VALUE CHECKING AND ADJUSTMENT

● Resetting the stopwatch hands to "0" position

Repeat "START" – "STOP" – "RESET" of the stopwatch several times to check if each of the three stopwatch hands returns to "0" position securely.

● Checking the time period of date change

Specified time period of date change: 0:00 a.m. ~ 0:03 a.m.

With the crown at the second click, advance the hour and minute hands until the date changes. Check if the date changes within the time period specified above.

● Remarks on measuring time accuracy

To measure the time accuracy, be sure to reset the stopwatch to "00". If the accuracy measurement is made while the stopwatch is counting, stable measurements may not be obtained.

● Current consumption

Current consumption measurement of Cal. 9T82A requires special tools, and the movement could be damaged during the procedure of current consumption measurement. We do not recommend, therefore, that you measure the current consumption for checking. It can be assumed that the current consumption is within the standard range as long as the movement is kept under proper conditions.