

TECHNICAL INFORMATION

ManualsLib.com
CITIZEN QUARTZ

Cal. No. 60※※※

Cal. No. 61※※※

(Except Cal. No. 6070※)



 **CITIZEN**

51. OUTLINE

Cal. 60 (for ladies) and Cal. 61 (for men) are series of thin analog quartz watches.

52. SPECIFICATIONS

Caliber No.	6000A-00	6010A-00	6020A-00	6030A-00/ 6031A-00	6040A-00/ 6045A-00	6100A-00/ 6101A-00	6110A-00/ 6111A-00
Type	Analog quartz watch						
	Three hands		Two hands	Three hands	Two hands + small second	Three hands	
Module size (mm)	φ18.1x16.1 x3.3t	φ18.1x16.1 3.0t	15.3x17.8x2.5t		φ18.1x15.3 x3.2t	φ23.3x22.6x3.3t	
Accuracy	±20 sec/month (at normal temperatures)						
Oscillation	32,768Hz						
Effective temp. range	-10°C ~ +60°C						
Integrated circuit	C/MOS-LSI 1 unit						
Converter	Bipolar step motor						
Time rate adjustment	D.F.C. (without a control terminal)						
Time rate measurement	10 seconds						
Additional functions	Date (with quick stopping device)	Yes (O) ←	No (X)	←	←	Yes (O)	←
	Day (with quick setting device)	Yes (O)	←	←	←	Yes (O)	No (X)
	Second hand stopping device	Yes (O)	←	No (X)	Yes (O)	←	←
	Power saving switch	Yes (O)	←	←	←	←	←
	Alarm	No (X)	←	←	←	←	←
Power cell	Part No.	280-34					
	Cell code	SR621SW					
	Size (mm)	φ6.8 x 2.1					
	Voltage	1.55V					
	Capacity	18mAH					
	Life	Approx. 2 years					
Current consumption							
Coil resistance							

53. HANDLING METHOD

3-1. Cal. 60/61 series

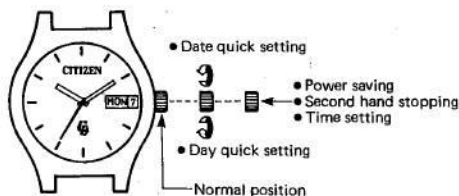

Use this watch similarly to general watches.

- The day quick setting function may not work while the day indicating system is working (from about 00:00 AM to about 04:00 AM).
- The date quick setting function may not work while the date indicating system is working (from about 10:30 PM to about 00:30 AM).

* After setting the time and calendar, push the crown into the normal position.

54. DISASSEMBLY AND ASSEMBLY OF THE MODULE

1. Cal. 60XXX/61XXX

Disassembling procedure : ① ~ ③②

Assembling procedure : ③② ~ ①

● Lubrication markings

- ⊗ A-Lube oil
- ⊙ V-Lube oil
- ⊕ F-Lube oil
- ⊘ CH-1 oil

This drawing shows the module of Cal. 6100. The modules of other Cal. 60 and 61 models are basically the same as this. Cal. 604XX is partly different from this. See 5. PRECAUTIONS IN DISASSEMBLY AND ASSEMBLY.

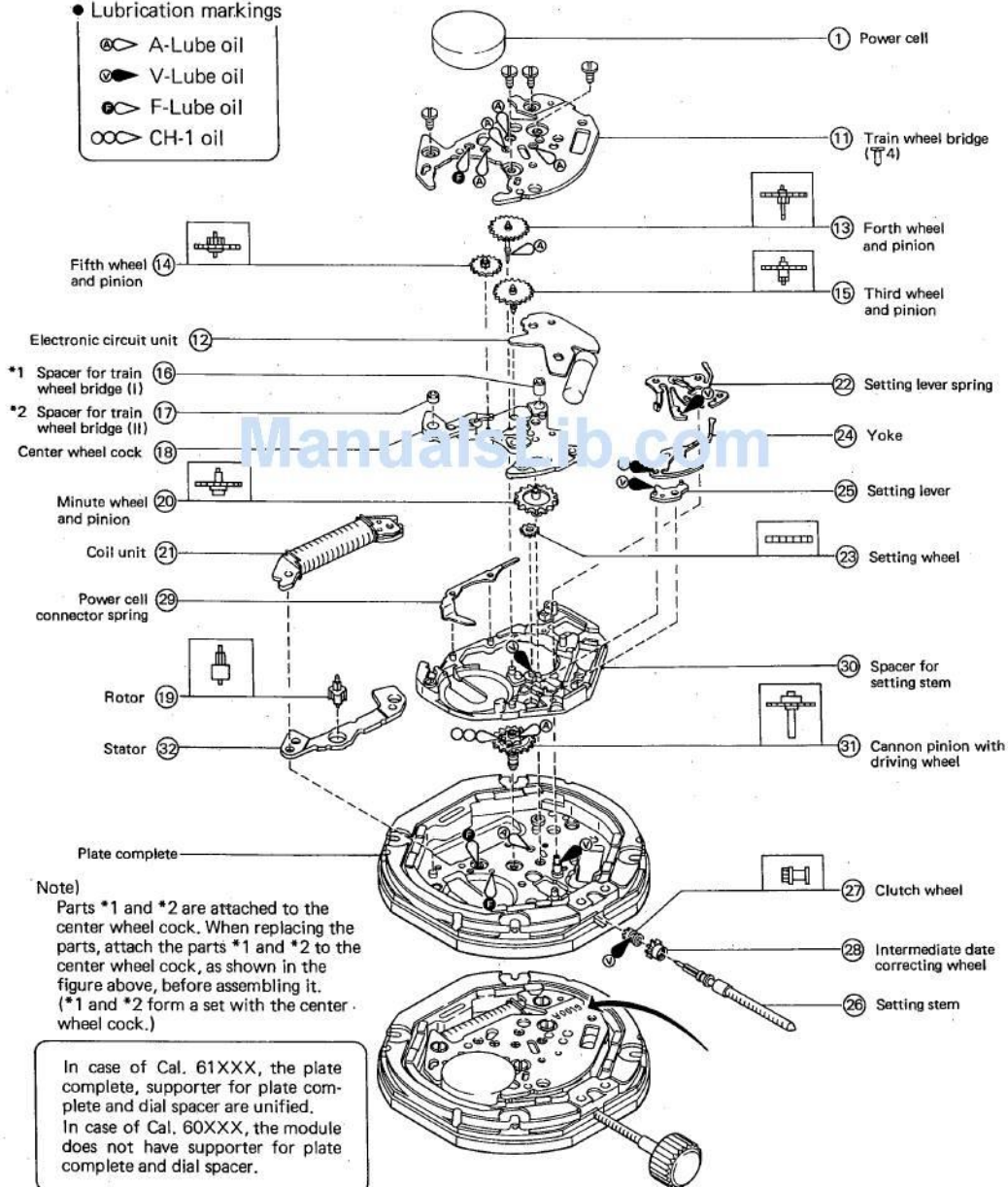

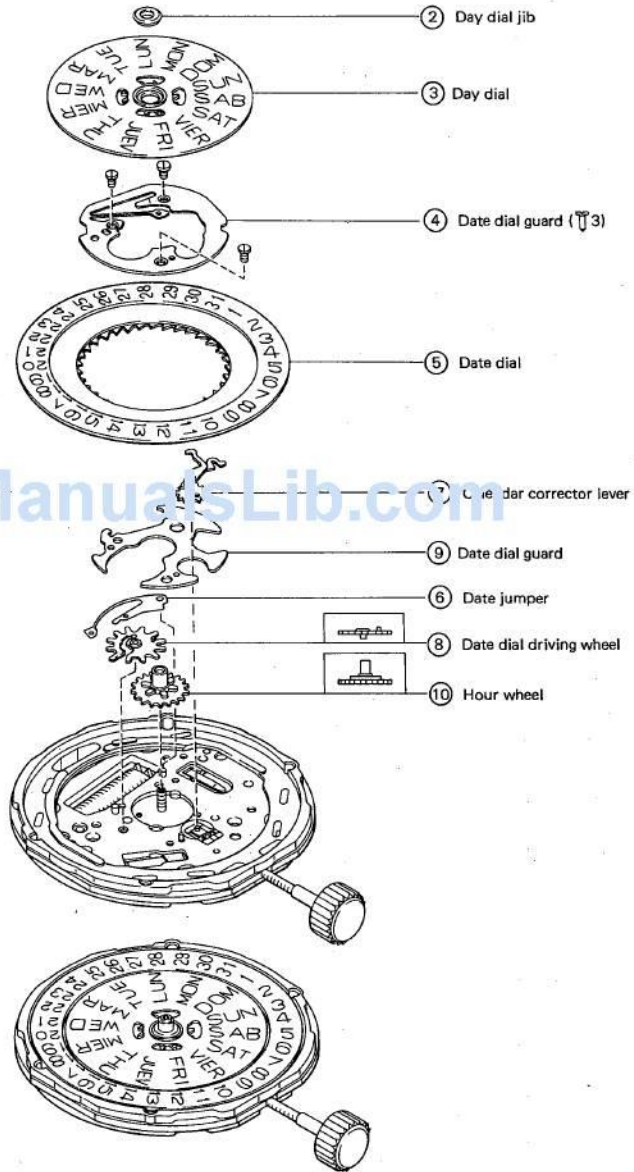

55. PRECAUTIONS IN DISASSEMBLY AND ASSEMBLY

Cal. 604XX has a small second hand, thus its structure is different from other Cal. 60 models in the following points. When disassembling and assembling the module of Cal. 604XX, observe the following points.

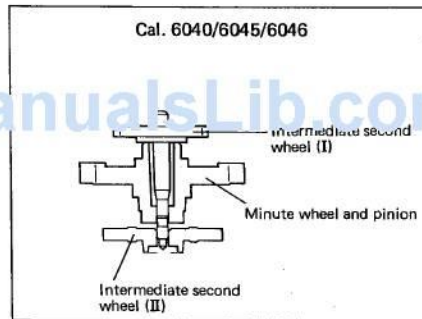
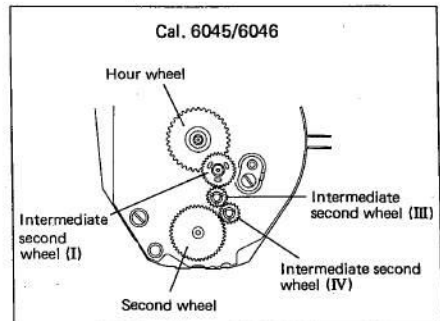
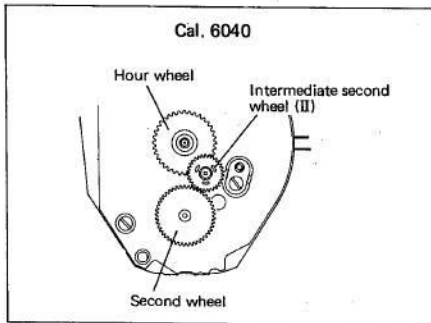

- The intermediate second wheel (II) has irregular shaft and hole. Mount it in the direction of the hole.
- Do not supply oil to intermediate second wheels (III) and (IV). (Oil cannot be supplied after they are assembled for a structural reason.)

6. TROUBLESHOOTING AND ADJUSTMENT

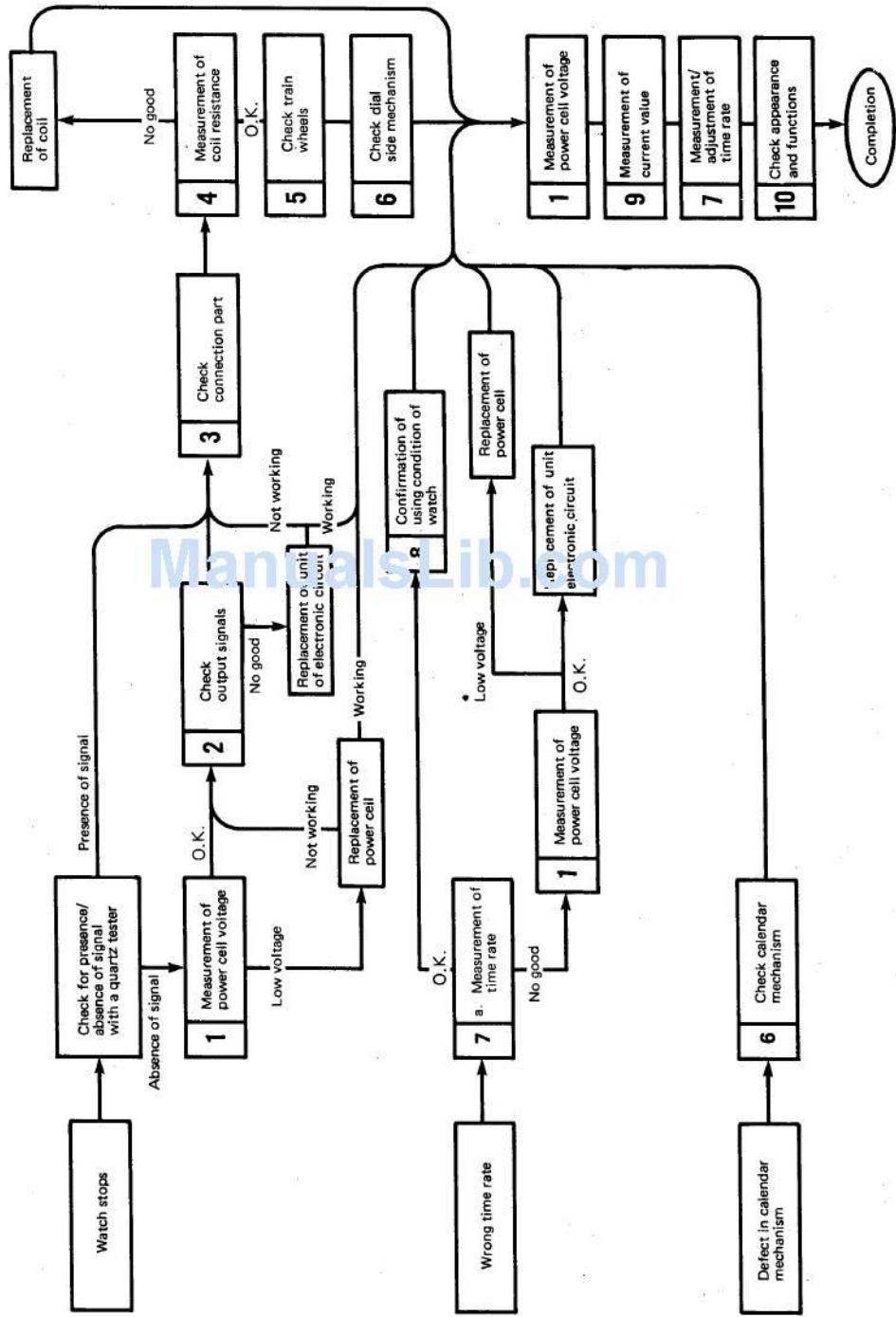

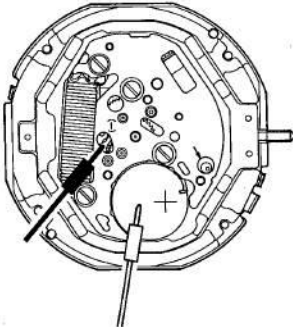
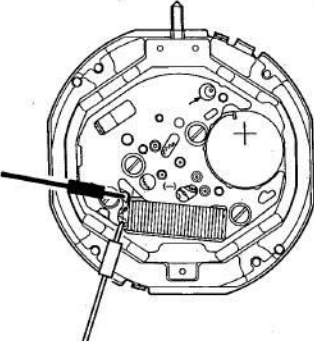
Check Items	Method	Results and Repair Procedure
<p>① Measurement of power cell voltage</p>	<p>[Refer to Technical Manual, Basic Course II-1-a for the setting procedure of the tester]</p> <p>(Parts to be measured)</p> 	<p>Measure the voltage on the complete module.</p> <p>Over 1.5V → Non-defective</p> <p>Under 1.5V → Measure the power cell separately</p> <p>Measurement of the separate power cell</p> <p>Over 1.5V → Check the connection parts</p> <p>Under 1.5V → Replace the power cell</p>
<p>② Check output signal</p>	<p>[Refer to Technical Manual, Basic Course II-1-b for the setting procedure of the tester]</p> <p>(Parts to be measured)</p> 	<p>The tester pointer swings over 0V at interval of 1 sec → Non-defective</p> <p>If the tester pointer does not swing → Check the connection parts.</p>
<p>③ Check connection part</p>	<p>[Refer to the analog part of Technical Manual, Basic Course II-2-a.]</p>	

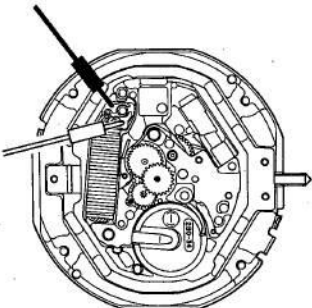
Check Items	Method	Results and Repair Procedure
<p>4 Measurement of coil resistance</p>	<p>[Refer to Technical Manual, Basic Course II-1-c for the setting procedure of the tester]</p> <p>(Parts to be measured)</p> 	<p>2.1kΩ ~ 2.5kΩ → Non-defective</p> <p>Outside range of 2.1kΩ ~ 2.5kΩ → Replace the coil unit</p>
<p>5 Check train wheel</p>	<p>[Refer to Technical Manual, Basic Course II-2-b.]</p>	<p>ManualsLib.com</p>
<p>6 Check dial side mechanism</p>	<p>[Refer to Technical Manual, Basic Course II-2-c.]</p>	<p>Hand is heavy → Supply oil CH-1 to the cannon pinion with driving wheel</p> <p>Deformed → Replace</p>
<p>7 Measurement and adjustment of time rate</p>	<p>Measurements are made in a 10 second range. Since this watch uses D.F.C. and has no control terminal, the time rate cannot be adjusted in the field.</p>	<p>If the watch loses or gains substantial time, replace the electronic circuit unit.</p>
<p>8 Confirmation of using conditions of watch</p>	<p>[Refer to Technical Manual, Basic Course II-1-f.]</p>	

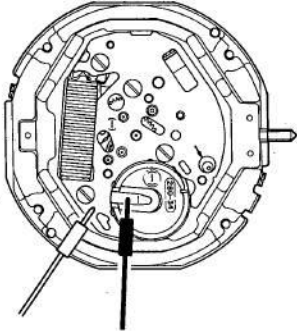
Check Items	Method	Results and Repair Procedure
<p>9 Measurement of current consumption</p>	<p>[Refer to Technical Manual, Basic Course II-1-f for the setting procedure of the tester]</p> <p>(Parts to be measured)</p>  <p>Influence of light</p> <p>Avoid measuring current consumption under an incandescent lamp or the direct rays of the sun, because it may cause the current value to increase. The high temperature of the lamp has no influence on the current value.</p>	<ul style="list-style-type: none"> ● Current consumption of the module <ul style="list-style-type: none"> Under 1.2μA → Non-defective Over 1.2μA → Measure the electronic circuit unit separately. ● Measurement of the separate electronic circuit unit <ul style="list-style-type: none"> Under 0.3μA → Non-defective Over 0.3μA → Replace the electronic circuit unit. <div style="border: 1px solid black; padding: 5px; margin-top: 10px;"> <p>When the current consumption of the module shows a high value, but that of the separation electronic circuit unit is normal. → There may be a problem somewhere outside the circuit. Therefore, inspect the watch for dusts, lubrication conditions and deformed parts, and remove the cause of the high load.</p> </div>
<p>10 Check appearance and functions</p>	<p>[Refer to Technical Manual, Basic Course II-2-f.]</p>	

ManualsLib.com
CITIZEN WATCH CO., LTD.
Tokyo, Japan
