

***TECHNICAL  
INFORMATION***

---

**CITIZEN QUARTZ**

**Cal. No. 951❖❖**

 **CITIZEN**

CONTENTS

- 1. OUTLINE ..... P1
- 2. FEATURES ..... P1
- 3. SPECIFICATIONS ..... P2
- 4. HANDLING INSTRUCTIONS ..... P3
- 5. DISASSEMBLY/ASSEMBLY OF MODULE ..... P8
- 6. NOTES ON DISASSEMBLY/ASSEMBLY ..... P9
- 7. TROUBLE SHOOTING AND ADJUSTMENT ..... P10

■1. Outline





This is a digital quartz watch for men, which is developed on the basis of the precedent Cal. No. 9460. It features a wide variation of designs to be one of the Citizen's prime digital watches with reasonable prices.

■2. FEATURES

- 1) The stopwatch function is capable of displaying 1/100 sec. timing and LAP timing up to 59'59''99.
- 2) The switching is independently possible between the 12-hour display with AM/PM and the 24-hour display and in the ordinary time display mode and the dual time display mode respectively.
- 3) DFC (Digital Frequency Control) system  
This caliber applies the DFC system in which the time rate is perfectly adjusted at the factory. Accordingly, no adjustment is carried out for the time rate on the market.
- 4) A long lifetime of about 6 years (3 sec. lighting of illumination lamp per day) is attained with use of a lithium power cell.
- 5) The push-buttons are provided at both sides of a case or at the single side plus on the upper face of a case respectively according to each watch. (See page 8.)  
The module is, however, equal between these two types of watches having different positions of push-buttons. (See page 8.)

### ■3. SPECIFICATIONS

Caliber No.		9510A	
Movement		Size : 27φmm Thickness : 4.98mm (incl. power cell part)	
Accuracy		±20 sec./month at normal temperatures	
Oscillation		32,768Hz	
Method of display		FE (Field Effect) type nematic LC (Liquid Crystal) with 2-split matrix driving	
Display functions	Ordinary display	Upper : Displays to be switched by selection of functions Middle : Constant display of month, date & day Lower : Constant display of hour, minute & second (12-hour display)  Constant display of hour, minute, second & 24H (24-hour display)	
	Upper display part	Calendar	Constant display: Month, date & day In correction mode: A/P display (12-hour display) plus year display at lower side
		Stop watch	 , minute, second & 1/100 sec. with lap function
		Dual time	 , hour, minute & A/P (12-hour display)  , hour and minute (24-hour display)
Correction of display		With operation of push-buttons	
Effective temperature range		±0°C ~ 55°C (32°F ~ 131°F)	
Integrated circuit		C/MOS-LSI (1 unit)	
Additional functions		<ul style="list-style-type: none"> <li>● Quick advance of time in correction mode</li> <li>● Illumination lamp</li> <li>● Fully automatic calendar (1980 ~ 2019)</li> <li>● Auto-return mechanism</li> <li>● Instant manual return mechanism</li> </ul>	
Power cell (Lithium)		Parts No. : 280-204 Maker code : CR2016 (Li/MnO <sub>2</sub> ) Nominal voltage: 3V Capacity : 55mAH Size : 20φmm x 1.6mm Lifetime : About 6 years (3 sec. lighting of illumination lamp per day)	

4. HANDLING INSTRUCTIONS

(A circle mark ○ shows the flashing.)

1) Name of each part

Example of display : 3 : 25 ' 36 " (12-hour display)  
Wednesday, July 2

- Stopwatch : Running (Lap running mode)

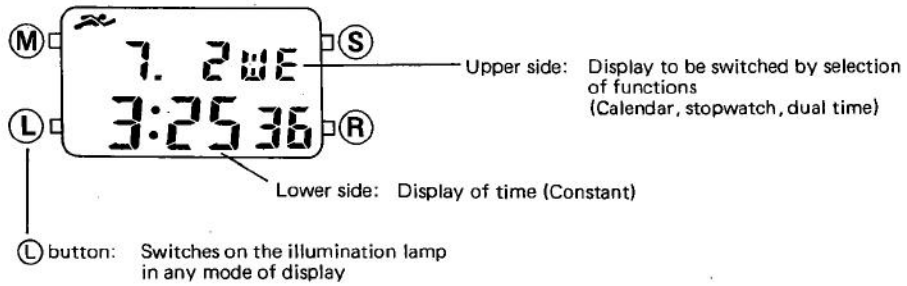

2) Switching of displays

The displays are switched in the following sequence with every push of (M) button.

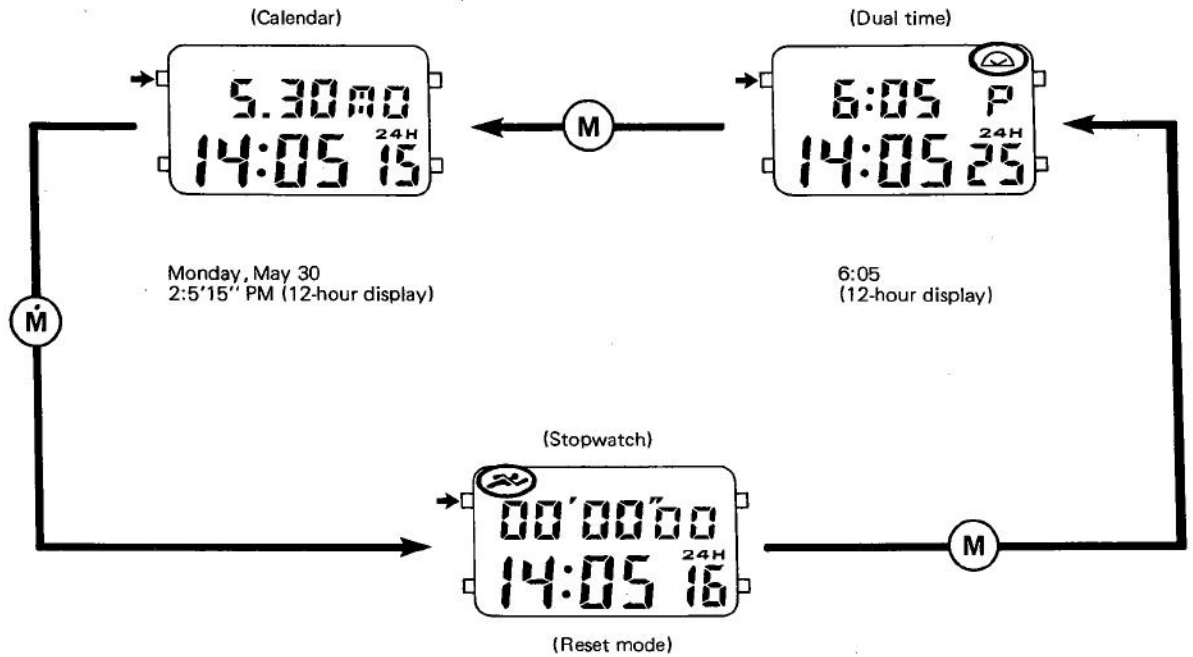

### 3) Switching between 12-/24-hour displays

The switching between the 12-hour and 24-hour displays is possible independently in the ordinary time mode and the dual time mode.

#### (1) Example of switching in ordinary time mode

\*The switching is carried out by consecutively pushing  $\text{\textcircled{R}}$  button about 2 seconds.

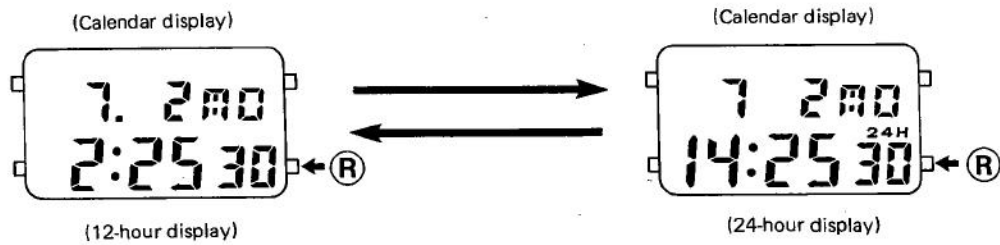

\*The switching is carried out by consecutively pushing  $\text{\textcircled{R}}$  button about 2 seconds.

#### (2) Example of switching in dual time mode

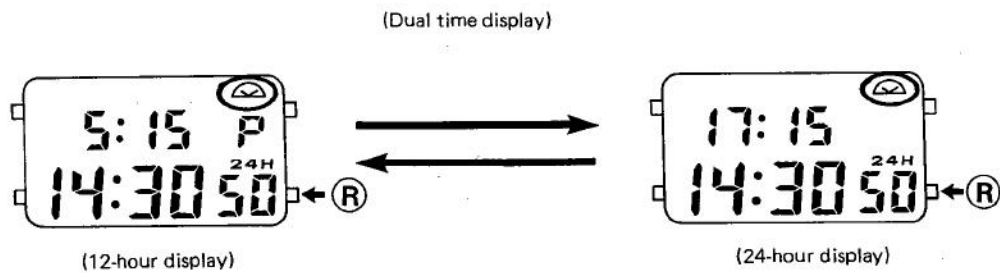

4) Operation in calendar display mode

(1) Correction of time

The digit to be corrected is called out by (S) button, and the time is corrected by (R) button. The (S) button is consecutively pushed about 2 seconds only when the second to be corrected is called out.

Example: "3:38 PM, Saturday, July 2, 1981" to be switched to "12:08 PM, Monday, September 25, 1981"

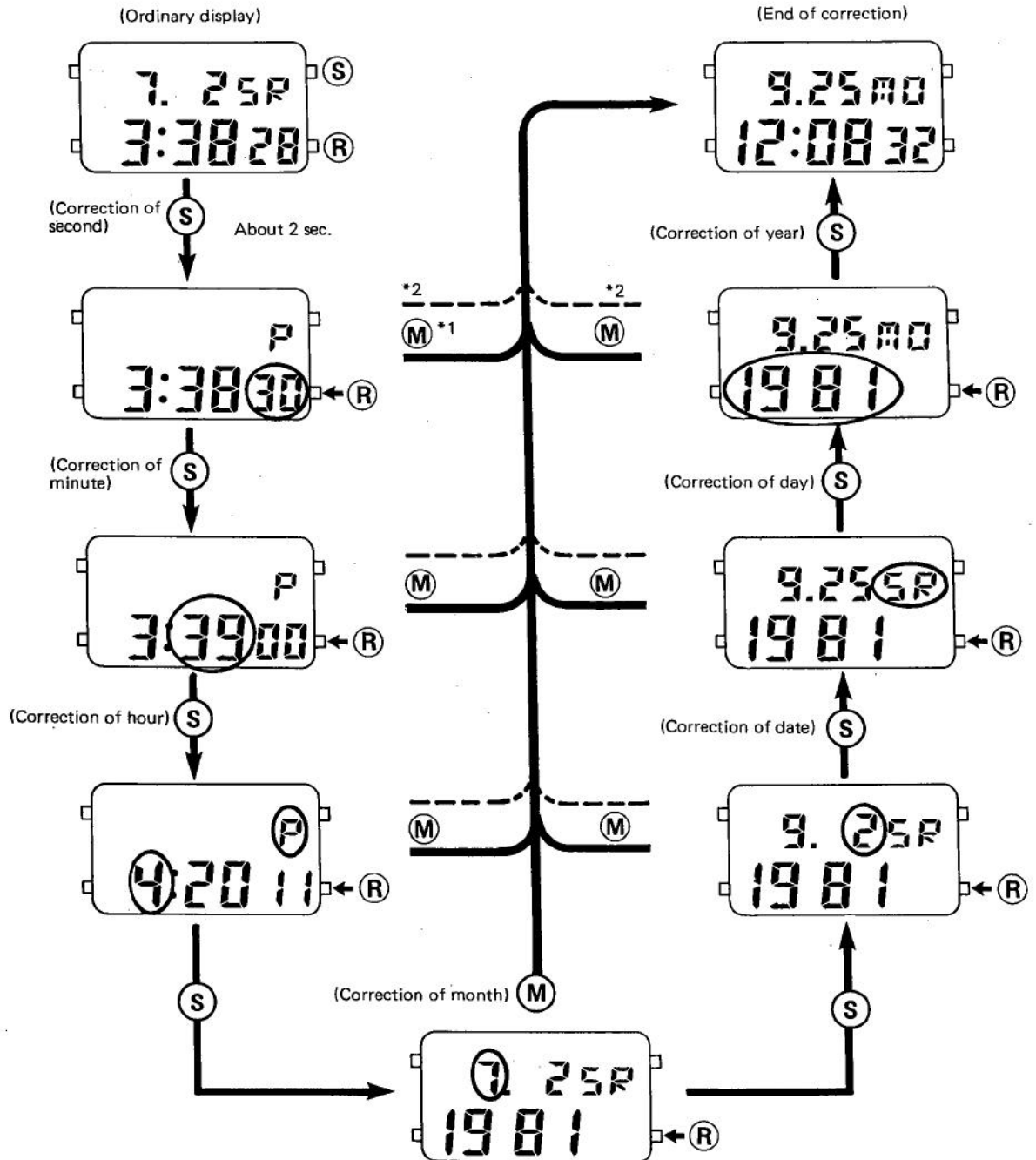

- \*1. Instant manual return ← (M)  
The ordinary display of time is reset in any mode of display by pushing (M) button.
- \*2. Auto-return ← ----  
The ordinary display of time is reset automatically in any mode of display if no push-button is operated for one to two minutes.
  - a) If the 0-second resetting is carried out with push of (R) button during the correction of second and while the second indicates 30 ~ 59, the minute is carried by a digit. However, no carrying of digit is performed in other corrections of time than the second since they are carried out independently.
  - b) The quick advance of time (8 Hz) is possible if (R) button is consecutively pushed for a second or longer in each mode of correction.
  - c) If a non-existing date is mistakenly set, reset the ordinary display of time from the mode of correction. Thus the first day of the following month is correctly set.

5) Operation of stopwatch

- Unit of measurement : 1/100 sec.
- Time of measurement : 59'59''99 (60-minute counting)

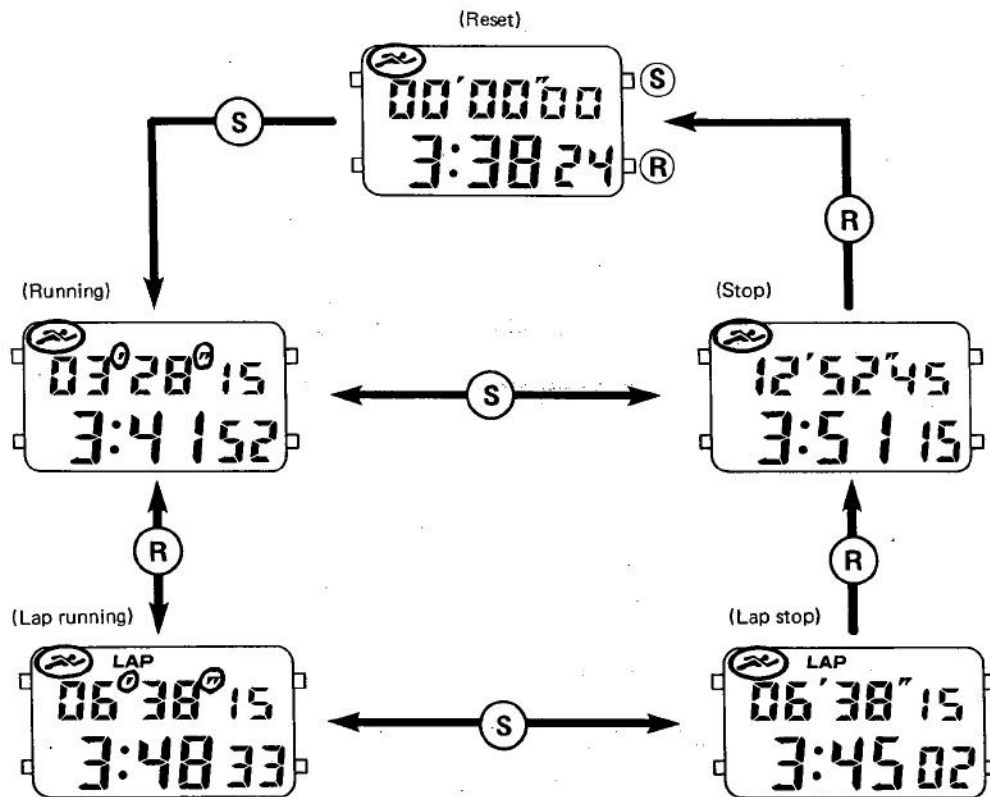

6) Operation in dual time mode

Example of display

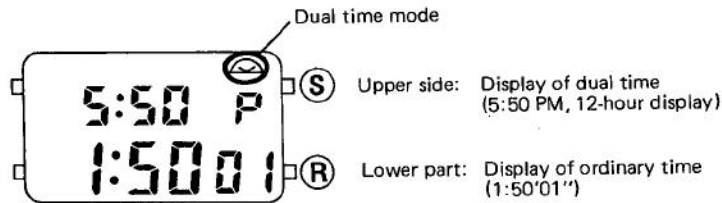

• Method of correction

The digit to be corrected is called out by (S) button, and the time is corrected by (R) button.

Example: "5:50 PM" to be switched to "8:30 PM"

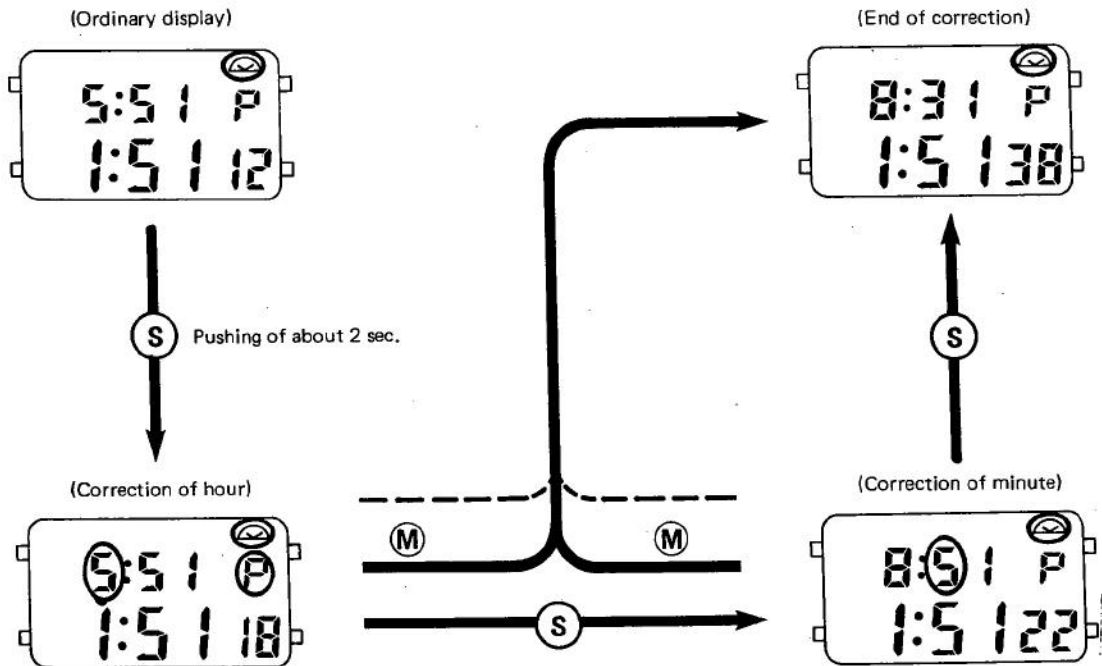

\*1. Instant manual return (← (M) )

\*2. Auto-return (←----)

\*3. The minute is corrected with every 10 minutes, and no correction is carried out with every minute.

(Ex.) 5:44 P → 5:54 P → 5:04 P

• The quick advance of time (8Hz) is possible in each mode of correction by consecutively pushing (R) button for a second or longer.