

MO0902-EA

CASIO®

Module No. 3132

Getting Acquainted

Congratulations upon your selection of this CASIO watch. To get the most out of your purchase, be sure to read this manual carefully.

- Be sure to keep all user documentation handy for future reference.
- **This watch does not have a time zone that corresponds to the UTC offset of -3.5 hours. Because of this, the radio-controlled timekeeping and World Time functions will not display the correct time for Newfoundland, Canada.**

Applications

The built-in sensors of this watch measure direction, barometric pressure, temperature and altitude. Measured values are then shown on the display. Such features make this watch useful when hiking, mountain climbing, or when engaging in other such outdoor activities.

Warning!

- The measurement functions built into this watch are not intended for taking measurements that require professional or industrial precision. Values produced by this watch should be considered as reasonable representations only.
- The Moon phase indicator and tide graph data that appear on the display of this watch are not intended for navigation purposes. Always use proper instruments and resources to obtain data for navigation purposes.
- This watch is not an instrument for calculating low tide and high tide times. The tide graph of this watch is intended to provide a reasonable approximation of tidal movements only.
- When engaging in mountain climbing or other activities in which losing your way can create a dangerous or life-threatening situation, always be sure to use a second compass to confirm direction readings.
- Note that CASIO COMPUTER CO., LTD. assumes no responsibility for any damage or loss suffered by you or any third party arising through the use of this product or its malfunction.

Keep the watch exposed to bright light

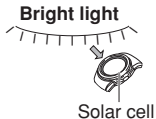

The electricity generated by the solar cell of the watch is stored by a built-in battery. Leaving or using the watch where it is not exposed to light causes the battery to run down. Make sure the watch is exposed to light as much as possible.

- When you are not wearing the watch on your wrist, position the face so it is pointed at a source of bright light.
- You should try to keep the watch outside of your sleeve as much as possible. Charging is reduced significantly if the face is covered only partially.

- The watch continues to operate, even when it is not exposed to light. Leaving the watch in the dark can cause the battery to run down, which will result in some watch functions being disabled. If the battery goes dead, you will have to re-configure watch settings after recharging. To ensure normal watch operation, be sure to keep it exposed to light as much as possible.

Battery charges in the light.

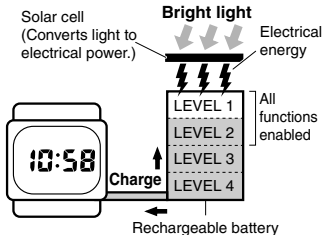

Battery discharges in the dark.

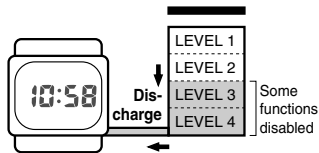

- The actual level at which some functions are disabled depends on the watch model.
- Frequent display illumination can run down the battery quickly and require charging. The following guidelines give an idea of the charging time required to recover from a single illumination operation.
 - Approximately five minutes exposure to bright sunlight coming in through a window*
 - Approximately 50 minutes exposure to indoor fluorescent lighting*
- **Be sure to read “Power Supply” (page E-105) for important information you need to know when exposing the watch to bright light.**

If the display of the watch is blank...

If the display of the watch is blank, it means that the watch's Power Saving function has turned off the display to conserve power.

- **See “Power Saving” (page E-130) for more information.**

About This Manual



- Button operations are indicated using the letters shown in the illustration.
- Each section of this manual provides you with the information you need to perform operations in each mode. Further details and technical information can be found in the “Reference” section.
- To ensure that this watch provides you with the years of service for which it is designed, be sure to carefully read and follow the instructions under “Operating Precautions” and “User Maintenance”.

Contents

General Guide	E-10
Radio-controlled Atomic Timekeeping	E-12
Digital Compass	E-34
Barometer/Thermometer	E-54
Altimeter	E-61
Recalling Altitude Data	E-70
Tide/Moon Data	E-73
Countdown Timer	E-81
Stopwatch	E-88
World Time	E-90
Alarms	E-92
Illumination	E-95
Questions & Answers	E-99
Power Supply	E-105
Timekeeping	E-113
Reference	E-121
Specifications	E-143
Operating Precautions	E-147
User Maintenance	E-153

Procedure Lookup

The following is a handy reference list of all the operational procedures contained in this manual.

<i>To specify your Home City</i>	<i>E-14</i>
<i>To perform manual receive</i>	<i>E-27</i>
<i>To turn auto receive on and off</i>	<i>E-29</i>
<i>To check the latest signal reception results</i>	<i>E-30</i>
<i>To enter and exit the Digital Compass Mode</i>	<i>E-35</i>
<i>To take a direction reading</i>	<i>E-36</i>
<i>To perform magnetic declination correction</i>	<i>E-43</i>
<i>To perform bidirectional calibration</i>	<i>E-45</i>
<i>To perform northerly calibration</i>	<i>E-46</i>
<i>To set a map and find your current location</i>	<i>E-49</i>
<i>To find the bearing to an objective</i>	<i>E-50</i>
<i>To determine the direction angle to an objective on a map and head in that direction</i>	<i>E-51</i>

<i>To take barometric pressure and temperature readings</i>	<i>E-54</i>
<i>To display your current altitude</i>	<i>E-64</i>
<i>To save an altitude reading</i>	<i>E-67</i>
<i>To set a reference altitude</i>	<i>E-68</i>
<i>To view altitude reading records and the high altitude record</i>	<i>E-71</i>
<i>To delete all altitude data currently in memory</i>	<i>E-72</i>
<i>To view Moon Data for a particular date, or Tide Data for a particular date and time</i>	<i>E-75</i>
<i>To adjust the high tide time</i>	<i>E-77</i>
<i>To reverse the displayed Moon phase</i>	<i>E-80</i>
<i>To configure countdown timer settings</i>	<i>E-85</i>
<i>To turn the progress beeper on and off</i>	<i>E-86</i>
<i>To use the countdown timer</i>	<i>E-87</i>
<i>To measure times with the stopwatch</i>	<i>E-89</i>
<i>To view the time in another city</i>	<i>E-90</i>

<i>To toggle a city code time between Standard Time and Daylight Saving Time</i>	<i>E-91</i>
<i>To set an alarm time</i>	<i>E-93</i>
<i>To test the alarm</i>	<i>E-94</i>
<i>To turn an alarm and the Hourly Time Signal on and off</i>	<i>E-94</i>
<i>To turn on illumination manually</i>	<i>E-95</i>
<i>To turn the auto light switch on and off</i>	<i>E-98</i>
<i>To set the time and date manually</i>	<i>E-115</i>
<i>To change the Daylight Saving Time (summer time) setting</i>	<i>E-119</i>
<i>To turn the button operation tone on and off</i>	<i>E-129</i>
<i>To recover from the sleep state</i>	<i>E-131</i>
<i>To turn Power Saving on and off</i>	<i>E-132</i>
<i>To calibrate the pressure sensor and the temperature sensor</i>	<i>E-141</i>

General Guide

- The illustration below shows which buttons you need to press to navigate between modes.
- In any mode, press (L) to illuminate the display.

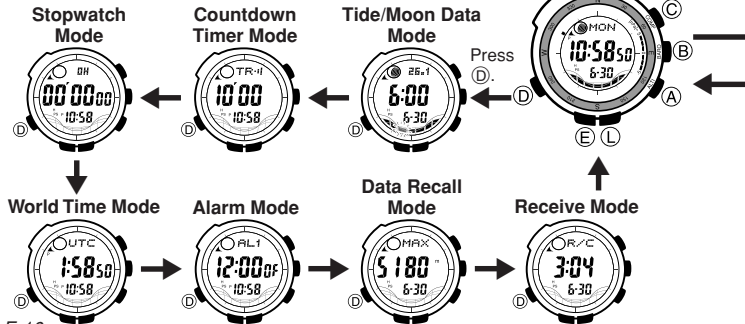

- You can use buttons (A), (B), and (C) to enter a sensor mode directly from the Timekeeping Mode or from another sensor mode. To enter a sensor mode from the Tide/Moon Data, Countdown Timer, Stopwatch, World Time, Alarm, Data Recall, or Receive Mode, first enter the Timekeeping Mode and then press the applicable button.

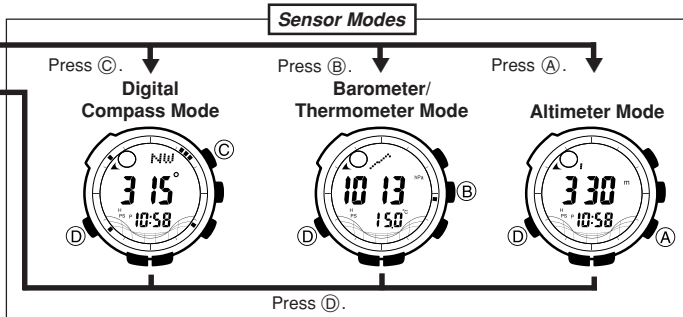

Radio-controlled Atomic Timekeeping

This watch receives a time calibration signal and updates its time setting accordingly.

- This watch is designed to pick up the time calibration signals transmitted in Germany (Mainflingen), England (Anthorn), the United States (Fort Collins) and Japan.
- See the information under “Signal Reception Troubleshooting” (page E-31) if you experience problems with time calibration signal reception.

Current Time Setting

This watch adjusts its time setting automatically in accordance with a time calibration signal. You also can perform a manual procedure to set the time and date, when necessary.

- **The first thing you should do after purchasing this watch is to specify your Home City (the city where you normally will use the watch). For more information, see “To specify your Home City” (page E-14).**

- When using the watch outside the areas covered by the time signal transmitters, you will have to adjust the current time setting manually as required. See “Timekeeping” (page E-113) for more information about manual time settings.
- The U.S. time calibration signal can be picked up by the watch while in North America. The term “North America” in this manual refers to the area that consists of Canada, the continental United States, and Mexico.

To specify your Home City

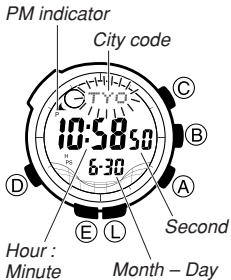

1. In the Timekeeping Mode, hold down (E) until the city code starts to flash, which indicates the setting screen.
2. Press (A) (east) and (C) (west) to select the city code you want to use as your Home City.

LON : London

PAR, BER : Paris, Berlin, Milan, Rome,
Amsterdam, Hamburg, Frankfurt,
Vienna, Barcelona, Madrid

ATH : Athens

HKG, TYO, SEL : Hong Kong, Tokyo, Seoul

HNL : Honolulu

ANC : Anchorage, Nome

LAX : Los Angeles, San Francisco, Las Vegas, Seattle/Tacoma,
Vancouver, Tijuana

DEN : Denver, El Paso, Edmonton, Culiacan

CHI : Chicago, Houston, Dallas/Fort Worth, New Orleans, Winnipeg,
Mexico City

NYC : New York, Detroit, Miami, Boston, Montreal

- For full information on city codes, see the “City Code Table” at the back of this manual.
- Note that this watch does not have a city code that corresponds to Newfoundland.

3. Press **(E)** to exit the setting screen.

- Normally, your watch should show the correct time as soon as you select your Home City code. If it does not, it should adjust automatically after the next auto receive operation (in the middle of the night). You also can perform manual receive (page E-27) or you can set the time manually (page E-115).
- The watch will receive the time calibration signal automatically from the applicable transmitter (in the middle of the night) and update its settings accordingly. For information about the relationship between city codes and transmitters, see page E-19 and “Transmitters” (page E-135).
- See the maps under “Approximate Reception Ranges” (page E-20) for information about the reception ranges of the watch.

- Under factory default settings, auto receive is turned off for all of the following city codes: **HKG** (Hong Kong), **HNL** (Honolulu), and **ANC** (Anchorage). For details about turning on auto receive for these city codes, see “To turn auto receive on and off” on page E-29.
- You can disable time signal reception, if you want. See “To turn auto receive on and off” on page E-29 for more information.

Time Calibration Signal Reception

There are two different methods you can use to receive the time calibration signal: auto receive and manual receive.

- **Auto Receive**

With auto receive, the watch receives the time calibration signal automatically up to six times a day. When any auto receive is successful, the remaining auto receive operations are not performed. For more information, see “About Auto Receive” (page E-22).

- **Manual Receive**

Manual receive lets you start a time calibration receive operation with the press of a button. For more information, see “To perform manual receive” (page E-27).

Important!

- When getting ready to receive the time calibration signal, position the watch as shown in the nearby illustration, with its 12 o'clock side facing towards a window. This watch is designed to receive a time calibration signal late at night. Because of this, you should place the watch near a window as shown in the illustration when you take it off at night. Make sure there are no metal objects nearby.

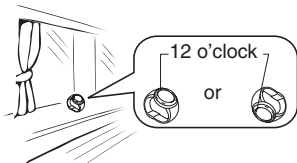

- Make sure the watch is facing the right way.

- Proper signal reception can be difficult or even impossible under the conditions listed below.



Inside or
among
buildings



Inside a
vehicle



Near
household
appliances,
office
equipment,
or a mobile
phone



Near a
construction
site, airport,
or other
sources of
electrical
noise



Near high-
tension
power lines



Among or
behind
mountains

- Signal reception normally is better at night than during the day.
- Time calibration signal reception takes from two to seven minutes, but in some cases it can take as long as 14 minutes. Take care that you do not perform any button operations or move the watch during this time.

- The time calibration signal the watch will attempt to pick up depends on its current Home City code setting as shown below.

Home City Code	Transmitter	Frequency
LON, PAR, BER, ATH	Anthorn (England)	60.0 kHz
	Mainflingen (Germany)	77.5 kHz
HKG*, TYO, SEL	Fukushima (Japan)	40.0 kHz
	Fukuoka/Saga (Japan)	60.0 kHz
HNL*, ANC*, LAX, DEN, CHI, NYC	Fort Collins, Colorado (United States)	60.0 kHz

- * The areas covered by the **HKG**, **HNL**, and **ANC** city codes are quite far from the time calibration signal transmitters, and so certain conditions may cause problems with signal reception.

Approximate Reception Ranges

U.K. and German Signals

1,500 kilometers

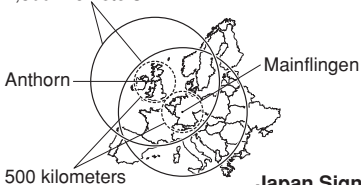

U.S. Signal

2,000 miles
(3,000 kilometers)

600 miles
(1,000 kilometers)

Fort
Collins

This map shows the reception ranges for U.S. signals. Two overlapping circles represent the ranges. The larger circle, centered at Fort Collins, has a radius of 2,000 miles (3,000 kilometers). The smaller circle, centered at an unspecified location, has a radius of 600 miles (1,000 kilometers). The map shows the outlines of North America.

Japan Signals

500
kilometers

Fukuoka/Saga

1,000
kilometers

500
kilometers

Fukushima

1,000
kilometers

This map shows the reception ranges for Japan signals. Two overlapping circles represent the ranges. The larger circle, centered at Fukuoka/Saga, has a radius of 1,000 kilometers. The smaller circle, centered at Fukushima, has a radius of 500 kilometers. The map shows the outlines of the Japanese archipelago.

- Signal reception may not be possible at the distances noted below during certain times of the year or day. Radio interference also may cause problems with reception.
 - Mainflingen (Germany) or Anthorn (England) transmitters: 500 kilometers (310 miles)
 - Fort Collins (United States) transmitter: 600 miles (1,000 kilometers)
 - Fukushima or Fukuoka/Saga (Japan) transmitters: 500 kilometers (310 miles)
- Even when the watch is within the reception range of the transmitter, signal reception will be impossible if the signal is blocked by mountains or other geological formations between the watch and signal source.
- Signal reception is affected by weather, atmospheric conditions, and seasonal changes.

About Auto Receive

The watch receives the time calibration signal automatically up to six times a day. When any auto receive is successful, the remaining auto receive operations are not performed. The reception schedule (calibration times) depends on your currently selected Home City, and whether standard time or Daylight Saving Time is selected for your Home City.

Your Home City		Auto Receive Start Times					
		1	2	3	4	5	6
LON	Standard Time	1:00 am	2:00 am	3:00 am	4:00 am	5:00 am	Midnight*
	Daylight Saving Time	2:00 am	3:00 am	4:00 am	5:00 am	Midnight*	1:00 am*
PAR BER	Standard Time	2:00 am	3:00 am	4:00 am	5:00 am	Midnight*	1:00 am*
	Daylight Saving Time	3:00 am	4:00 am	5:00 am	Midnight*	1:00 am*	2:00 am*
ATH	Standard Time	3:00 am	4:00 am	5:00 am	Midnight*	1:00 am*	2:00 am*
	Daylight Saving Time	4:00 am	5:00 am	Midnight*	1:00 am*	2:00 am*	3:00 am*

Your Home City		Auto Receive Start Times					
		1	2	3	4	5	6
HKG, SEL, TYO	Standard Time	Midnight	1:00 am	2:00 am	3:00 am	4:00 am	5:00 am
HNL, ANC, LAX, DEN, CHI, NYC	Standard Time and Daylight Saving Time	Midnight	1:00 am	2:00 am	3:00 am	4:00 am	5:00 am

*Next day

Note

- When a calibration time is reached, the watch will receive the calibration signal only if it is in either the Timekeeping Mode or World Time Mode. Reception is not performed if a calibration time is reached while you are configuring settings.
- Auto receive of the calibration signal is designed to be performed early in the morning, while you sleep (provided that the Timekeeping Mode time is set correctly). Before going to bed for the night, remove the watch from your wrist, and put it in a location where it can receive the signal easily.

- The watch takes from two to 14 minutes to receive the time calibration signal whenever a calibration time is reached. Do not perform any button operation within 14 minutes before or after any one of the calibration times. Doing so can interfere with correct calibration.
- Remember that reception of the calibration signal depends on the current time in the Timekeeping Mode. The receive operation will be performed whenever the display shows any one of the calibration times, regardless of whether or not the displayed time actually is the correct time.

About the Receiving Indicator

The receiving indicator shows the strength of the calibration signal being received. For best reception, be sure to keep the watch in a location where signal strength is strongest. The receiving indicator is displayed while an auto or manual receive operation is in progress.

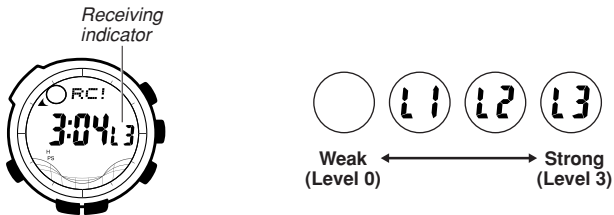

- Even in an area where signal strength is strong, it takes about 10 seconds for signal reception to stabilize enough for the receiving indicator to indicate signal strength.

- Use the receiving indicator as a guide for checking signal strength and for finding the best location for the watch during signal receive operations.
- Following reception of the time calibration signal and calibration of the watch's time setting, a "settings updated" indicator (▲) will remain on the display in all modes. The settings updated indicator (▲) will not be displayed if signal reception was unsuccessful or after you adjust the current time setting manually.
- The settings updated indicator (▲) appears only when the watch is able to receive both time and date data successfully. It does not appear when only time data is received.
- The settings updated indicator (▲) indicates that at least one of the auto calibration signal receive operations was successful. Note, however, that the indicator disappears from the display each day at the start of the first auto receive operation of the day.

To perform manual receive

Receiving



Receive successful



1. Enter the Receive Mode (page E-10).
2. Place the watch on a stable surface so its 12 o'clock side is facing towards a window (page E-17).
3. Hold down (A) for about two seconds until **RC!** appears on the display.
 - Time calibration signal reception takes from two to seven minutes, but in some cases it can take as long as 14 minutes. Take care that you do not perform any button operations or move the watch during this time.
 - If the receive operation is successful, the reception date and time appear on the display, along with the **GET** indicator. The watch will enter the Receive Mode if you press (A) or if you do not perform any button operation for about one or two minutes.

Receive failed

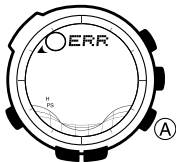

If there was a previously successful reception

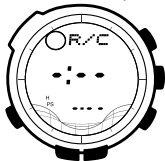

If no reception has been successful

E-28

- If the current reception fails but a previous reception was successful, the display shows the previous reception's date and time, and the **ERR** indicator. -:- - indicates that none of the reception operations have been successful during the current date.

The watch will enter the Receive Mode without changing the time setting if you press **(A)** or if you do not perform any button operation for about one or two minutes.

Note

- To interrupt a receive operation and return to the Receive Mode, press **(A)**.

To turn auto receive on and off

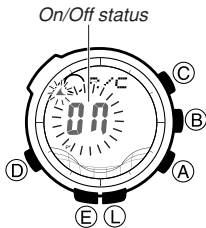

1. Enter the Receive Mode (page E-10).
2. In the Receive Mode, hold down (E) until the current auto receive setting (ON or OFF) starts to flash. This is the setting screen.
 - Note that the setting screen will not appear if the currently selected Home City is one that does not support time calibration reception.
3. Press (A) to toggle auto receive on (ON) and off (OFF).
4. Press (E) to exit the setting screen.
 - For information about city codes that support signal receive, see “To specify your Home City” (page E-14).

To check the latest signal reception results



Enter the Receive Mode (page E-10).

- When receive is successful, the display shows the time and date that receive was successful.
 - :- - indicates that none of the reception operations were successful.
- To return to the Timekeeping Mode, press (D).

Signal Reception Troubleshooting

Check the following points whenever you experience problems with signal reception.

Problem	Probable Cause	What you should do
Cannot perform manual receive.	<ul style="list-style-type: none">• The watch is not in the Receive Mode.• Your current Home City is not one of the following: LON, PAR, BER, ATH, HKG, SEL, TYO, HNL, ANC, LAX, DEN, CHI, or NYC	<ul style="list-style-type: none">• Enter the Receive Mode and try again.• Select one of the cities to the left as your Home City (page E-14).
Auto receive is turned on, but the settings updated indicator (▲) does not appear on the display.	<ul style="list-style-type: none">• You changed the time setting manually.• You changed the DST setting of your Home City in the World Time Mode.• You pressed a button while signal receive was in progress.	<ul style="list-style-type: none">• Perform manual signal receive or wait until the next auto signal receive operation is performed.

Problem	Probable Cause	What you should do
<p>Auto receive is turned on, but the settings updated indicator (▲) does not appear on the display.</p>	<ul style="list-style-type: none"> • Even if receive is successful, the settings updated indicator (▲) disappears from the display each day when the first auto receive operation of the day is performed. • Time data (hour, minute, second) only was received during the last receive operation. The settings updated indicator (▲) appears only when time data and date data (year, month, day) are both received. 	<ul style="list-style-type: none"> • Check to make sure the watch is in a location where it can receive the signal (page E-17).

Problem	Probable Cause	What you should do
Time setting is incorrect following signal reception.	<ul style="list-style-type: none"> • If the time is one hour off, the DST setting may be incorrect. • The Home City code setting is not correct for the area where you are using the watch. 	<ul style="list-style-type: none"> • Change the DST setting to Auto DST (page E-119). • Select the correct Home City code (page E-14).

- For further information, see “Important!” (page E-17) and “Radio-controlled Atomic Timekeeping Precautions” (page E-133).

Digital Compass

A built-in bearing sensor detects magnetic north and indicates one of 16 directions on the display. Direction readings are performed in the Digital Compass Mode.

- You can calibrate the bearing sensor (page E-41) if you suspect the direction reading is incorrect.
- See “Using the Digital Compass While Mountain Climbing or Hiking” (page E-48) for some real-life examples of how to use this feature.

To enter and exit the Digital Compass Mode

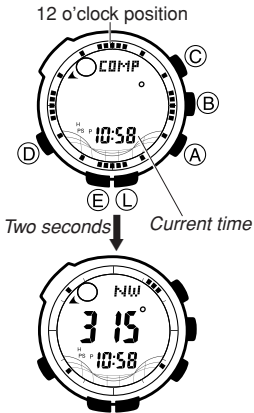

1. While in the Timekeeping Mode or in any of the other sensor modes, press **(C)** to enter the Digital Compass Mode.
 - At this time, the watch will start a Digital Compass operation. After about two seconds, letters appear on the display to indicate the direction that the 12 o'clock position of the watch is pointing.
 - The direction reading on the display is updated each second for up to 20 seconds, after which measurement stops automatically.
2. Press **(D)** to return to the Timekeeping Mode.

To take a direction reading

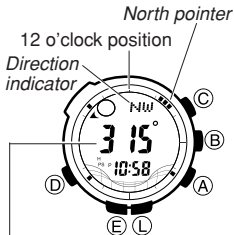

Angle value (in degrees)

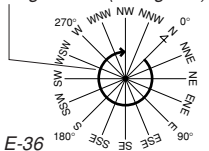

E-36

1. While the watch is in the Digital Compass Mode, place it on a flat surface, or if you are wearing the watch, make sure that your wrist is horizontal (in relation to the horizon).
2. Point the 12 o'clock position of the watch in the direction you want to measure.
3. Press **C** to start a Digital Compass measurement operation.
 - After about two seconds, the direction that the 12 o'clock position of the watch is pointing appears on the display.
 - Also, four pointers appear to indicate magnetic north, south, east, and west.
 - After the first reading is obtained, the watch continues to take direction readings automatically each second, for up to 20 seconds.

- While the watch is taking compass readings, it displays a direction angle, a direction indicator, and four direction pointers, all of which change dynamically when the watch is moved. The direction angle, direction indicator and direction pointers all disappear from the display after the compass reading operation is complete. Use the direction indicators imprinted on the bezel to record the indicated direction. For details, see “Using the Digital Compass While Mountain Climbing or Hiking” (page E-48).

Note

- Note that taking a measurement while the watch is not horizontal (in relation to the horizon) can result in large measurement error.

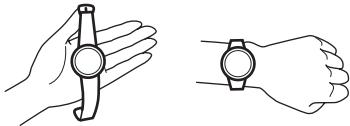

- The margin of error for the angle value and the direction indicator is ± 11 degrees. If the indicated direction is northwest (**NW**) and 315 degrees, for example, the actual direction can be anywhere from 304 to 326 degrees.

- Any ongoing direction measurement operation is paused temporarily while the watch is performing an alert operation (daily alarm, Hourly Time Signal, countdown timer alarm) or while illumination is turned on (by pressing **L**). The measurement operation resumes for its remaining duration after the operation that caused it to pause is finished.
- The following table shows the meanings of each of the direction abbreviations that appear on the display.

Direction	Meaning	Direction	Meaning	Direction	Meaning	Direction	Meaning
N	North	NNE	North-northeast	NE	Northeast	ENE	East-northeast
E	East	ESE	East-southeast	SE	Southeast	SSE	South-southeast
S	South	SSW	South-southwest	SW	Southwest	WSW	West-southwest
W	West	WNW	West-northwest	NW	Northwest	NNW	North-northwest

- See “Digital Compass Precautions” (page E-39) for other important information about taking direction readings.

Digital Compass Precautions

This watch features a built-in magnetic bearing sensor that detects terrestrial magnetism. This means that north indicated by this watch is magnetic north, which is somewhat different from true polar north. The magnetic north pole is located in northern Canada, while the magnetic south pole is in southern Australia. Note that the difference between magnetic north and true north as measured with all magnetic compasses tends to be greater as one gets closer to either of the magnetic poles. You also should remember that some maps indicate true north (instead of magnetic north), and so you should make allowances when using such maps with this watch.

Location

- Taking a direction reading when you are near a source of strong magnetism can cause large errors in readings. Because of this, you should avoid taking direction readings while in the vicinity of the following types of objects: permanent magnets (magnetic necklaces, etc.), concentrations of metal (metal doors, lockers, etc.), high tension wires, aerial wires, household appliances (TVs, personal computers, washing machines, freezers, etc.)

- Accurate direction readings are impossible while in a train, boat, air plane, etc.
- Accurate readings also are impossible indoors, especially inside ferro-concrete structures. This is because the metal framework of such structures picks up magnetism from appliances, etc.

Storage

- The precision of the bearing sensor may deteriorate if the watch becomes magnetized. Because of this, you should be sure to store the watch away from magnets or any other sources of strong magnetism, including: permanent magnets (magnetic necklaces, etc.) and household appliances (TVs, personal computers, washing machines, freezers, etc.)
- Whenever you suspect that the watch may have become magnetized, perform one of the calibration procedures under “Calibrating the Bearing Sensor” (page E-41).

Calibrating the Bearing Sensor

You should calibrate the bearing sensor whenever you feel that the direction readings being produced by the watch are off. There are three different calibration methods available: magnetic declination correction, bidirectional calibration, and northerly calibration.

- **Magnetic Declination Correction**

With magnetic declination correction, you input a magnetic declination angle (difference between magnetic north and true north), which allows the watch to indicate true north.

You can perform this procedure when the magnetic declination angle is indicated on the map you are using.

Note that you can input the declination angle in degree units only, so you may need to round off the value specified on the map. If your map indicates the declination angle as 7.4° , you should input 7° . In the case of 7.6° input 8° , for 7.5° you can input 7° or 8° .

- **Bidirectional Calibration and Northerly Calibration**

Bidirectional calibration and northerly calibration calibrate the accuracy of the direction sensor in relation to magnetic north.

Use bidirectional calibration when you want to take readings within an area exposed to magnetic force. This type of calibration should be used if the watch becomes magnetized for any reason. With northerly calibration, you “teach” the watch which way is north (which you have to determine with another compass or some other means).

Important!

- If you want to perform both bidirectional and northerly calibration, be sure to perform bidirectional calibration first, and then perform northerly calibration. This is necessary because bidirectional calibration cancels any existing northerly calibration setting.
- The more correctly you perform bidirectional calibration, the better the accuracy of the bearing sensor readouts. You should perform bidirectional calibration whenever you change environments where you use the bearing sensor, and whenever you feel that the bearing sensor is producing incorrect readings.

To perform magnetic declination correction

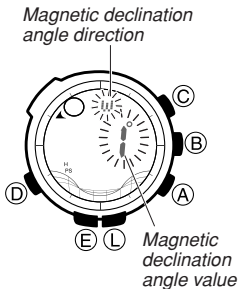

1. In the Digital Compass Mode, hold down (E) for about two seconds until the magnetic declination angle and magnetic declination angle direction values start to flash on the display. This is the setting screen.
2. Use (A) (+) and (C) (-) to change the magnetic declination angle and magnetic declination angle direction settings.
 - You can select a value within the range of **W 90°** to **E 90°** with these settings.
 - The following explains magnetic declination angle direction settings.
OFF: No magnetic declination correction performed. The magnetic declination angle with this setting is 0°.

E: When magnetic north is to the east (east declination)

W: When magnetic north is to the west (west declination)



- You can turn off (**OFF**) magnetic declination correction (which effectively makes the magnetic declination angle: 0°) by pressing (A) and (C) at the same time.
 - The illustration on page E-43, for example, shows the value you should input and the direction setting you should select when the map shows a magnetic declination of 1° West.
3. When the setting is the way you want, press (E) to exit the setting screen.

Precautions about bidirectional calibration

- You can use any two opposing directions for bidirectional calibration. You must, however, make sure that they are 180 degrees opposite each other. Remember that if you perform the procedure incorrectly, you will get wrong bearing sensor readings.
- Make sure that you do not move the watch while calibration of either direction is in progress.
- You should perform bidirectional calibration in an environment that is the same as that where you plan to be taking direction readings. If you plan to take direction readings in an open field, for example, calibrate in an open field.

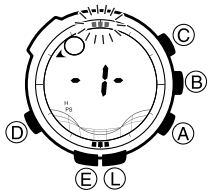
To perform bidirectional calibration



1. In the Digital Compass Mode, hold down (E) for about two seconds until the magnetic declination angle and magnetic declination angle direction values start to flash on the display. This is the setting screen.
2. Press (D) to display the bidirectional calibration screen.
 - At this time, the north pointer flashes at the 12 o'clock position to indicate that the watch is ready to calibrate the first direction.
3. Place the watch on a level surface facing any direction you want, and press (C) to calibrate the first direction.
 - - - - is shown on the display while calibration is being performed. When calibration is successful, the display will show  and , and the north pointer flashes at the 6 o'clock position. This means that the watch is ready for calibration of the second direction.
4. Rotate the watch 180 degrees.

5. Press **(C)** again to calibrate the second direction.
 - - - - is shown on the display while calibration is being performed. When calibration is successful, the display will show  and the Digital Compass Mode (showing the angle value) screen.
 - If - - - appears and then changes to **ERR** (error) on the calibration screen, it means that there is something wrong with the sensor. When **ERR** disappears after about one second, try performing the calibration again. If **ERR** keeps appearing, contact your original dealer or nearest authorized CASIO distributor to have the watch checked.

To perform northerly calibration

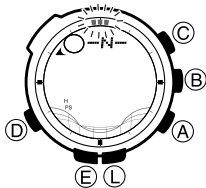

1. In the Digital Compass Mode, hold down **(E)** for about two seconds until the magnetic declination angle and magnetic declination angle direction values start to flash on the display. This is the setting screen.
2. Press **(D)** twice to display the northerly calibration screen.
 - At this time,  (north) appears on the display.

3. Place the watch on a level surface, and position it so that its 12 o'clock position points north (as measured with another compass).
4. Press **Ⓢ** to start the calibration operation.
 - **-----** is shown on the display while calibration is being performed. When calibration is successful, the display will show **OK** and the Digital Compass Mode (with **0°** shown as the angle value).
 - If **-----** appears and then changes to **ERR** (error) on the calibration screen, it means that there is something wrong with the sensor. When **ERR** disappears after about one second, try performing the calibration again. If **ERR** keeps appearing, contact your original dealer or nearest authorized CASIO distributor to have the watch checked.

Using the Digital Compass While Mountain Climbing or Hiking

This section describes three real-life situations where you could use the watch's built-in digital compass.

- To set a map and find your current location (page E-49)
Having an idea of your current location is important when mountain climbing or hiking. To do this, you need to “set the map”, which means to align the map so the directions indicated on it are aligned with the actual directions of your location. Basically what you are doing is aligning north on the map with north as indicated by the watch.
- To find the bearing to an objective (page E-50)
- To determine the direction angle to an objective on a map and head in that direction (page E-51)

To set a map and find your current location

North indicated
on the map

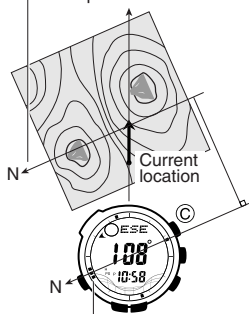

North indicated by
north pointer

1. With the watch on your wrist, position it so the face is horizontal.
2. In the Timekeeping, Digital Compass, Barometer/Thermometer, or Altimeter Mode, press **Ⓢ** to take a compass reading.
 - The reading will appear on the display after about two seconds.
3. Rotate the map without moving the watch so the northerly direction indicated on the map matches north as indicated by the watch.
 - If the watch is configured to indicate magnetic north, align the map's magnetic north with the watch indication. If the watch has been configured with a declination to correct to true north, align the map's true north with the watch indication.
 - This will position the map in accordance with your current location.
4. Determine your location as you check the geographic contours around you.

To find the bearing to an objective

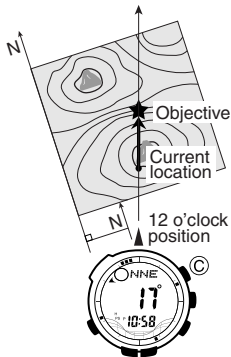

1. Take a compass reading and then set the map so its northerly indication is aligned with north as indicated by the watch, and determine your current location.
 - See “To set a map and find your current location” on page E-49 for information about how to perform the above step.
2. Set the map so the direction you want to travel on the map is pointed straight in front of you.
3. With the watch on your wrist, position it so the face is horizontal.
4. In the Timekeeping, Digital Compass, Barometer/Thermometer, or Altimeter Mode, press © to take a compass reading.
 - The reading will appear on the display after about two seconds.
5. Still holding the map in front of you, turn your body until north as indicated by the watch and the northerly direction on the map are aligned.

- This will position the map relative to your current location, so the bearing to your objective is straight ahead of you.

To determine the direction angle to an objective on a map and head in that direction

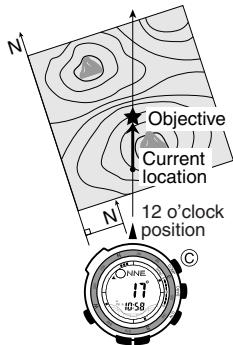

Note

- The following procedure is possible only with a watch that has a rotary bezel.
1. Take a compass reading and then set the map so its northerly indication is aligned with north as indicated by the watch, and determine your current location.
 - See “To set a map and find your current location” on page E-49 for information about how to perform the above step.
 2. As shown in the illustration to the left, change your position so you (and the 12 o'clock position of the watch) are pointed in the direction of objective, while keeping the map aligned with the readings being produced by the watch.

- If you find it difficult to perform the above step while keeping everything aligned, first move into the correct position (12 o'clock position of the watch pointed at the objective) without worrying about the orientation of the map. Next, perform step 1 again to set the map.

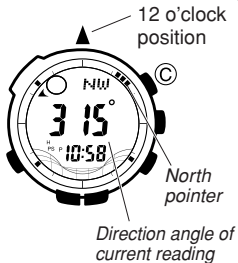

3. In the Timekeeping, Digital Compass, Barometer/Thermometer, or Altimeter Mode, press © to take a compass reading.
 - The compass reading information (angle value, direction indicator, and four pointers based on the 12 o'clock position of the watch) will appear on the display after about two seconds.
 - The compass reading information will remain on the display for only about 20 seconds after you press ©. After that it will disappear. If you want to re-display the compass reading information, press © again to take another reading.

4. Rotate the bezel so the “N” (North) indicator on the bezel is aligned with the north indicator produced by the reading in step 3.
5. To advance to your objective proceed in the direction that 12 o'clock is pointing.

Note

- When mountain climbing or hiking, conditions or geographic contours may make it impossible for you to advance in a straight line. If this happens, return to step 1 and save a new direction to the objective.

Barometer/Thermometer

This watch uses a pressure sensor to measure air pressure (barometric pressure) and a temperature sensor to measure temperature.

- You can calibrate the pressure sensor and the temperature sensor (page E-141) if you suspect that readings are incorrect.

To take barometric pressure and temperature readings

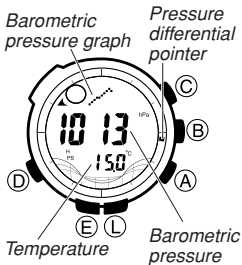

Pressing (B) in the Timekeeping Mode or in any of other sensor modes enters the Barometer/Thermometer Mode and starts barometric pressure and temperature measurements automatically .

- It can take up to four or five seconds for the barometric pressure reading to appear after you enter the Barometer/Thermometer Mode.
- Barometric pressure is displayed in units of 1hPa.

- The displayed barometric pressure value changes to - - - - hPa if a measured barometric pressure falls outside the range of 260 hPa to 1100 hPa. The barometric pressure value will reappear as soon as the measured barometric pressure is within the allowable range.
- Temperature is displayed in units of 0.1°C.
- The displayed temperature value changes to - - - . -°C if a measured temperature falls outside the range of -10.0°C to 60.0°C. The temperature value will reappear as soon as the measured temperature is within the allowable range.
- In some areas, barometric pressure is expressed in millibars (mb) instead of hectopascals (hPa). It really makes no difference, because 1hPa = 1mb.
- See “Barometer and Thermometer Precautions” (page E-139) for important precautions.

Barometric Pressure Graph

Barometric pressure indicates changes in the atmosphere. By monitoring these changes you can predict the weather with reasonable accuracy.

This watch takes barometric pressure measurements automatically every two hours (at the top of each even-numbered hour), regardless of its current mode. Measurement results are used to produce barometric pressure graph and barometric pressure differential pointer readings.

The barometric pressure graph shows readings of previous measurements for up to 20 hours. The horizontal axis of the graph represents time, with each dot standing for two hours. The rightmost dot represents the most recent reading. The vertical axis of the graph represents barometric pressure, with each dot standing for the relative difference between its reading and that of the dots next to it. Each dot represents 1hPa.

The following shows how to interpret the data that appears on the barometric pressure graph.



A rising graph generally means improving weather.



A falling graph generally means deteriorating weather.

Note that if there are sudden changes in barometric pressure or temperature, the graph line of past measurements may run off the top or bottom of the display. The entire graph will become visible once barometric conditions stabilize.

The following conditions cause the barometric pressure measurement to be skipped, with the corresponding point on the barometric pressure graph being left blank.

- Barometric reading that is out of range (260 hPa to 1,100 hPa)
- Sensor malfunction



Not visible on the display.

Barometric Pressure Differential Pointer

This pointer indicates the relative difference between the most recent barometric pressure reading indicated on the barometric pressure graph (page E-56), and the current barometric pressure value displayed in the Barometer/Thermometer Mode (page E-54).

- Pressure differential is indicated in the range of ± 5 hPa, in 1-hPa units.
- The barometric pressure differential pointer is not displayed when the displayed current barometric value is outside of the allowable measurement range (260 to 1,100 hPa).

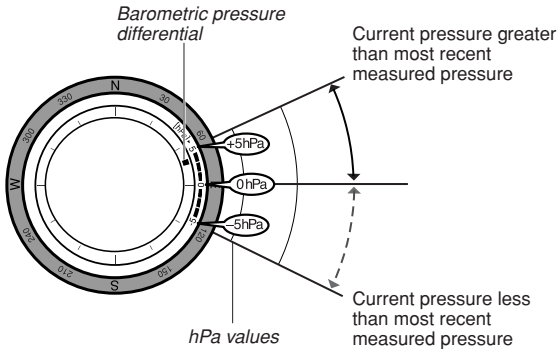

About Barometric and Temperature Measurements

- Barometric pressure and temperature measurement operations are performed as soon as you enter the Barometer/Thermometer Mode. After that, barometric pressure and temperature measurements are taken every five seconds.
- You also can perform a barometric pressure and temperature measurement at any time by pressing **Ⓑ** in the Barometer/Thermometer Mode.

Altimeter

The watch's altimeter uses a pressure sensor to detect current air pressure, which is then used to estimate the current altitude based on ISA (International Standard Atmosphere) preset values. You also can specify a reference altitude, which the watch will use to calculate your current altitude based on the value you specify. Altimeter functions also include storage of measurement data in memory.

Important!

- This watch estimates altitude based on air pressure. This means that altitude readings for the same location may vary if air pressure changes.
- The semiconductor pressure sensor used by the watch for altitude measurements also is affected by temperature. When taking altitude measurements, make sure the watch is not subjected to temperature changes.
- To avoid the effect of sudden temperature changes during measurement, keep the watch on your wrist in direct contact with your skin.

- Do not rely upon this watch for altitude measurements or perform button operations while sky diving, hang gliding, or paragliding, while riding a gyrocopter, glider, or any other aircraft, or while engaging in any other activity where there is the chance of sudden altitude changes.
- Do not use this watch for measuring altitude in applications that demand professional or industrial level precision.
- Remember that the air inside of a commercial aircraft is pressurized. Because of this, the readings produced by this watch will not match the altitude readings announced or indicated the flight crew.

How the Altimeter Measures Altitude

The altimeter can measure altitude based on its own preset values, or a reference altitude specified by you.

When you measure altitude based on preset values

Data produced by the watch's barometric pressure sensor is converted to approximate altitude based on ISA (International Standard Atmosphere) conversion values stored in watch memory.

When you measure altitude using a reference altitude specified by you

After you specify a reference altitude, the watch uses that value to convert the current measured barometric pressure value to altitude.

- When mountain climbing, you can set the reference value in accordance with a marker along the way or altitude information from a map. After that, the altitude readings produced by the watch will be more accurate than they would without a reference altitude.



Displaying Your Current Altitude

You can use the procedure described in this section to display your current altitude. If you leave the watch in the Altimeter Mode, it will update the displayed altitude value regularly, and indicate reading-to-reading changes in the altitude graph at the top of the display (page E-64).

Important!

- The procedure in this section simply displays values indicating your current altitude, without storing them in watch memory. For information about recording altitude readings in watch memory, see “Saving Altitude Data” (page E-66).

To display your current altitude

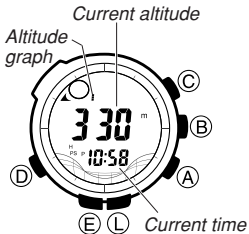

1. Press (A) in the Timekeeping Mode or in any of the other sensor modes to enter the Altimeter Mode.
 - The watch will start altitude measurement automatically, and display the result.
 - It can take up to four or five seconds for the altitude reading to appear after you enter the Altimeter Mode.
2. Leave the watch in the Altimeter Mode if you want the displayed altitude value and the altitude graph contents to be updated at regular intervals.
 - Readings are taken at five-second intervals for the first three minutes after you enter the Altimeter Mode. After that, readings are taken at two-minute intervals.
 - If you want to restart the altitude measurement operation at any point, press (A).
3. To stop the altitude measurement operation, press (D) to exit the Altimeter Mode.

Notes

- Normally, displayed altitude values are based on the watch's preset conversion values. You also can specify a reference altitude, if you want. See "Specifying a Reference Altitude" (page E-68).
- Altitude is displayed in units of 5 meters.
- The measurement range for altitude is -700 to 10,000 meters.
- The measured altitude may be a negative value in cases where there is a reference altitude value set or because of certain atmospheric conditions.
- The displayed altitude value changes to - - - - meters if a measured altitude falls outside the measurement range. The altitude value will be displayed again as soon as the measured altitude is within the allowable range.

Saving Altitude Data

The watch automatically keeps track of the high altitude achieved to date. You also can save altitude readings with the touch of a button.

- You can recall and view altitude data using the Data Recall Mode. For details, see “Recalling Altitude Data” (page E-70).

Automatic High Altitude Record

Whenever an altitude measurement in the Altimeter Mode is greater than the currently stored high altitude value, the watch will replace the old value with the new measurement automatically, along with the reading date and time. This feature is always enabled and cannot be turned off.

- If the current reading is the same as the existing high altitude value, the older value will be retained.

Saving an Altitude Reading

Perform the following procedure whenever you want to save an altitude reading.

To save an altitude reading



1. Press (A) to enter the Altimeter Mode (page E-11).
 2. Hold down (A) until **REC** flashes on the display.
 - At this time the watch will beep and the current altitude reading value will be saved along with the reading date (month - day) and time.
 3. **REC** will stop flashing and the watch will return to the Altimeter Mode automatically after data save is complete.
- Memory can store up to 24 altitude records. Storing a new reading while there are already 24 in memory will delete the oldest record currently in memory to make room for the new reading.

Specifying a Reference Altitude

After you specify a reference altitude, the watch adjusts its air-pressure-to-altitude conversion calculation accordingly. The altitude measurements produced by this watch are subject to error caused by changes in air pressure. Because of this, we recommend that you update the reference altitude whenever one is available during your climb.

To set a reference altitude

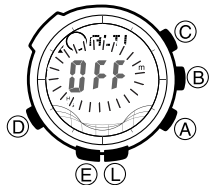

1. In the Altimeter Mode, hold down (E) for about two seconds until either **OFF** or the current reference altitude value starts to flash. This is the setting screen.
2. Press (A) (+) or (C) (-) to change the current reference altitude value by 5 meters.
 - You can set the reference altitude within the range of -10,000 to 10,000 meters.

- Pressing (A) and (C) at the same time returns to **OFF** (no reference altitude), so the watch performs air pressure to altitude conversions based on preset data only.
3. Press (E) to exit the setting screen.

Altitude graph

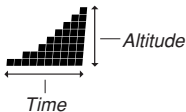

The altitude graph shows Altimeter Mode measurement results.

- The vertical axis of the graph represents altitude, and each dot stands for 10 meters.
 - The horizontal axis represents time, and the flashing dot in the rightmost column indicates the latest measurement result. For the first three minutes, each dot represents five seconds. After that, each dot represents two minutes.
- An out of range measurement result or a measurement error will cause the column of dots for that measurement to be blank (skipped).

Recalling Altitude Data

In the Data Recall Mode, you can recall and view altitude reading records you stored in the Altimeter Mode, as well as the high altitude record.

- All of the operations in this section are performed in the Data Recall Mode (page E-10).

Data Screens

The following explains the contents of each of the screens that appear in the Data Recall Mode.

Note

- While the altitude record or high altitude screen is displayed, the bottom part of the display alternates between the measurement date (month and day) and measurement time, at 1-second intervals.

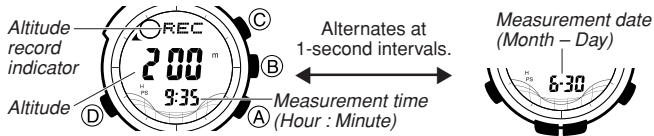

To view altitude reading records and the high altitude record

- Enter the Data Recall Mode.
 - After about one second a record with **MAX** on the top will appear. This is the high altitude record.
- Use (A) (+) and (C) (-) to scroll through the other altitude reading records.

To delete all altitude data currently in memory

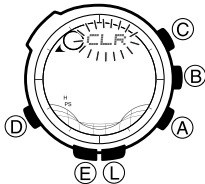

1. In the Data Recall Mode, hold down (E) until **CLR** flashes on the display and the watch beeps twice.
 - Releasing (E) at any time while **CLR** is flashing on the display will cancel the delete operation.
2. Keep (E) depressed for two seconds.
 - The watch will beep to indicate that all of the altitude data stored in watch memory (including readings you stored and the high altitude value) is deleted.

Tide/Moon Data

In the Tide/Moon Data Mode, you can see the current tide and the current date's Moon phase for your Home City. You can specify a date and view tide and Moon data for that date.

- See “Moon Phase Indicator” (page E-122) for information about the Moon phase indicator and “Tide Graph” (page E-125) for information about the tide graph.
- All of the operations in this section are performed in the Tide/Moon Data Mode (page E-10).

Tide Data

The Tide Graph that appears first when you enter the Tide/Moon Data Mode shows the data at 6:00 a.m. for your currently selected Home City on the current date, according to the Timekeeping Mode. From there you can specify another date or time.

- If the tide data is not correct, check your Timekeeping Mode settings and correct them if necessary.
- If you feel that the information shown by the Tide Graph is different from actual tide conditions, you need to adjust the high tide time. See “Adjusting the High Tide Time” (page E-76) for more information.

Moon Data

The Moon phase and Moon age information that appears first when you enter the Tide/Moon Data Mode shows the data at noon for your currently selected Home City on the current date, according to the Timekeeping Mode. After that you can specify another date to view data.

- If the Moon data is not correct, check your Timekeeping Mode settings and correct them if necessary.

- If the Moon phase indicator shows a phase that is a mirror image of the actual moon phase in your area, you can use the procedure under “Reversing the Displayed Moon Phase” (page E-79) to change it.

To view Moon Data for a particular date, or Tide Data for a particular date and time

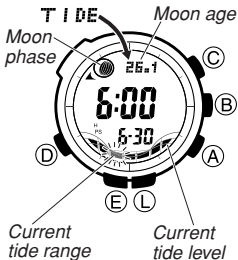

1. In the Tide/Moon Data Mode, use Ⓐ (+) and Ⓒ (–) to select the date you want.
 - After you select a date, the watch starts to calculate Moon and tide data for the date you selected. The calculation operation takes about 10 seconds, and is indicated by movement in the Moon Phase indicator and the Tide Graph on the display. You can use Ⓐ and Ⓒ to change to another date while a calculation operation is in progress.
 - After calculation is complete, the Moon information (Moon age and phase) and tide information (current tide level and tide range) will be displayed for the date you selected.

2. While the Moon information (Moon age and phase) and tide information (tide level and tide range for the current date) are displayed, you can press **(B) (+)** to advance the displayed tide range by one hour.
- You also can use **(A) (+)** and **(C) (-)** to change the date.
 - Update of the Moon Phase indicator and the Tide Graph is stopped while any of the following is occurring.

During button operation

While an alarm is sounding

While a countdown beeper is sounding

During display illumination

During Auto Receive of a time calibration signal

During a 2-hour barometric pressure reading operation

Adjusting the High Tide Time

Use the following procedure to adjust the high tide time within a particular date. You can find out high tide information for your area from a tide table, the Internet, or your local newspaper.

To adjust the high tide time



1. In the Tide/Moon Data Mode, use (A) (+) and (C) (-) to select the date you want.
 - After you select a date, the watch starts to calculate Moon and tide data for the date you selected. The calculation operation takes about 10 seconds, and is indicated by movement in the Moon Phase indicator and the Tide Graph on the display. You can use (A) and (C) to change to another date while a calculation operation is in progress.
 - After calculation is complete, the Moon information (Moon age and phase) and tide information (current tide level and tide range) will be displayed for the date you selected.

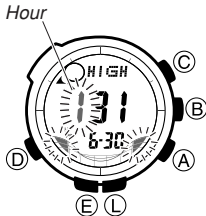

2. While the Moon information (Moon age and phase) and tide information (current tide level and tide range) are displayed, hold down (E) until the hour digits start to flash. This is the high tide time hour adjustment screen.
3. Use (A) (+) and (C) (-) to change the hour setting.
4. When the hour is the setting you want, press (D).
 - This will cause the minute digits to flash.
5. Use (A) (+) and (C) (-) to change the minute setting.
6. When the minute setting is the way you want, press (E) to exit the adjustment screen and return to the Tide/Moon Data Mode screen.

- Pressing Ⓐ and Ⓒ at the same time while the time adjustment screen is displayed (steps 2 through 5 above) will return the high tide time to its initial factory default setting.
- The high tide time setting is not affected by the DST (summer time) setting of the Timekeeping Mode.
- On some days, there are two high tides. With this watch, you can adjust the first high tide time only. The second high tide time for that day is adjusted automatically based on the first high tide time.

Reversing the Displayed Moon Phase

The left-right (east-west) appearance of the Moon depends on whether the Moon is north of you (northerly view) or south of you (southerly view) as you view it.

You can use the procedure below to reverse the displayed Moon phase so it matches the actual appearance of the Moon where you are located.

- To determine the viewing direction of the Moon, use a compass to take a direction reading of the Moon at its meridian passage.
- For information about the Moon phase indicator, see “Moon Phase Indicator” (page E-122).

To reverse the displayed Moon phase

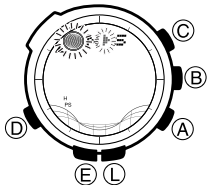

1. In the Tide/Moon Data Mode, hold down (E) until the hour digits start to flash.
2. Press (D) twice.
 - This will cause the Moon phase indicator to flash. This is the indicator switching screen.
3. Press (A) to toggle the Moon phase indicator between the southerly view (indicated by N+S) and northerly view (indicated by N+S).
 - Northerly view: Moon is north of you.
 - Southerly view: Moon is south of you.
4. When the Moon phase indicator setting is the way you want, press (E) to exit the switching screen and return to the Tide/Moon Data Mode screen.

Countdown Timer

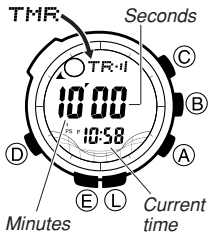

The countdown timer can be set within a range of one minute to 60 minutes. An alarm sounds when the timer reaches zero. The press of a button will start the countdown timer from the currently set start time, and a progress beeper sounds to keep you informed of the current status of the countdown. These features make it possible to use the watch for yacht racing.

- All of the operations in this section are performed in the Countdown Timer Mode, which you enter by pressing (D) (page E-10).

Configuring Countdown Timer Settings

The following are the settings you should configure before actually using the countdown timer.

- Countdown start time and reset time*
- Progress beeper (on/off)*

- See “To configure countdown timer settings” (page E-85) for information about setting up the timer.
- For details about the progress beeper, see “Progress Beeper” (page E-83).

Reset Time

You can set a “reset time”, which is a kind of alternate countdown start time you can recall with the press of a button any time a countdown operation is in progress.

Countdown Timer Beeper Operations

The watch beeps at various times during a countdown so you can keep informed about the countdown status without looking at the display. The following describes the types of beeper operations the watch performs during a countdown.

Countdown End Beeper

The watch beeps each second of the final 10 seconds before a countdown reaches zero, and at zero. The first five beeps (seconds 10 through 6) are higher pitched than the final five beeps (seconds 5 through 1). The watch emits a longer beep to signal when the countdown reaches zero.

Progress Beeper

The progress beeper actually includes two beepers: a reset time beeper and a reset period beeper.

- Note that the reset time beeper and reset period beeper operate only while the progress beeper is turned on. For more information, see “To turn the progress beeper on and off” (page E-86).

Reset Time Beeper

The reset time beeper is similar to the countdown end beeper. The watch beeps each second of the final 10 seconds before the countdown reaches the reset time.

Reset Period Beeper

The reset period is the portion of the countdown between the reset time and zero. While timing is in the reset period, the watch will beep four times at the top of each minute and 10 seconds before the end of the countdown.

Countdown Timer Examples

Countdown start time: 10 minutes; Reset time: 5 minutes

Progress beeper: On

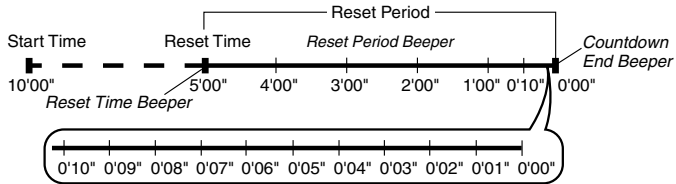

To configure countdown timer settings



1. While the countdown start time is on the display in the Countdown Timer Mode, hold down (E) until the countdown start time setting starts to flash, which indicates the setting screen.
 - If the countdown start time is not displayed, use the procedure under “To use the countdown timer” (page E-87) to display it.
2. Press (D) to move the flashing in the sequence shown below to select other settings.



3. When the setting you want to change is flashing, use (A) and (C) to change it as described below.

Setting	Screen	Button Operations
Start Time	TMR 10'00	Use (A) (+) and (C) (-) to change the setting. • You can set a start time in the range of 1 to 60 minutes in 1-minute increments.
Reset Time	RST 05'00	Use (A) (+) and (C) (-) to change the setting. • You can set a reset time in the range of 1 to 5 minutes in 1-minute increments.

4. Press (E) to exit the setting screen.

- The reset time setting must be less than the countdown start time setting.

To turn the progress beeper on and off

Pressing (B) while the countdown start time is on the display or while a countdown timer operation is in progress in the Countdown Timer Mode toggles progress beeper operation on (TR·H displayed) and off (TR displayed).

To use the countdown timer



In the Countdown Timer Mode, press (A) to start the countdown timer.

- The countdown timer measurement operation continues even if you exit the Countdown Timer Mode.
- The table below describes button operations you can perform to control countdown operations.

To do this:	Do this:
Stop the countdown operation	Press (A).
Resume a stopped countdown operation	Press (A) again.
Display the countdown start time	While the countdown is stopped, press (C).
Stop the countdown operation and display the reset time	Press (C).
Start the countdown from the displayed reset time	Press (A).

Stopwatch

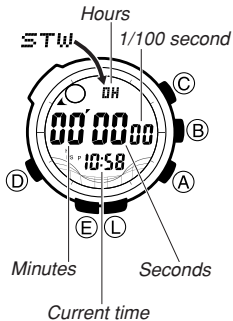

The stopwatch lets you measure elapsed time, split times, and two finishes.

- The display range of the stopwatch is 23 hours, 59 minutes, 59.99 seconds.
- The stopwatch continues to run, restarting from zero after it reaches its limit, until you stop it.
- The stopwatch measurement operation continues even if you exit the Stopwatch Mode.
- Exiting the Stopwatch Mode while a split time is frozen on the display clears the split time and returns to elapsed time measurement.
- All of the operations in this section are performed in the Stopwatch Mode, which you enter by pressing (D) (page E-10).

To measure times with the stopwatch

Elapsed Time

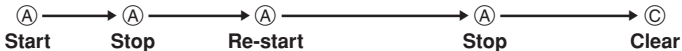

Split Time

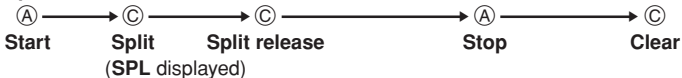

Two Finishes



World Time

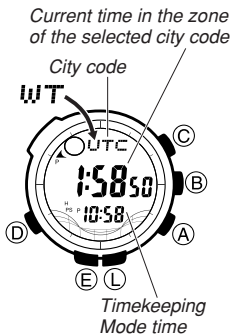

World Time displays the current time in 33 cities (29 time zones) around the world.

- If the current time shown for a city is wrong, check your Home City time settings and make the necessary changes (page E-115).
- All of the operations in this section are performed in the World Time Mode, which you enter by pressing (D) (page E-10).

To view the time in another city

In the World Time Mode, use (A) (east) and (C) (west) to scroll through city codes (time zones).

- For full information on city codes, see the “City Code Table” at the back of this manual.

To toggle a city code time between Standard Time and Daylight Saving Time

DST indicator



1. In the World Time Mode, use (A) (east) and (C) (west) to display the city code (time zone) whose Standard Time/Daylight Saving Time setting you want to change.
 2. Hold down (E) to toggle between Daylight Saving Time (**DST** indicator displayed) and Standard Time (**DST** indicator not displayed).
- The **DST** indicator appears on the display whenever you display a city code for which Daylight Saving Time is turned on.
- You cannot toggle between Daylight Saving Time and Standard Time if the displayed city code is **UTC**.
 - Note that the DST/Standard Time setting affects only the currently displayed city code. Other city codes are not affected.

Alarms

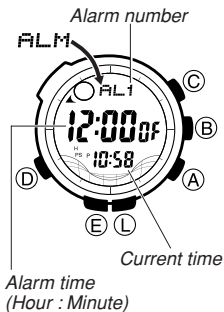

You can set five independent daily alarms. When an alarm is turned on, the alarm tone sounds when the alarm time is reached.

You also can turn on an Hourly Time Signal, which will cause the watch to beep twice every hour on the hour.

- The alarm number (**AL1** through **AL5**) indicates an alarm screen. **SIG** is shown when the Hourly Time Signal screen is on the display.
- When you enter the Alarm Mode, the data you were viewing when you last exited the mode appears first.
- All of the operations in this section are performed in the Alarm Mode, which you enter by pressing **(D)** (page E-10).

To set an alarm time

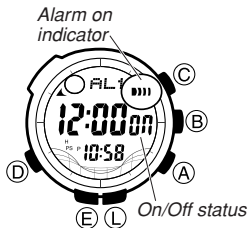

1. In the Alarm Mode, use (A) and (C) to scroll through the alarm screens until the one whose time you want to set is displayed.

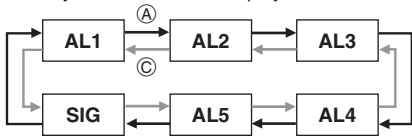

2. Hold down (E) until the hour setting of the alarm time start to flash, which indicates the setting screen.
 - This automatically turns on the alarm.
3. Press (D) to move the flashing between the hour and minute settings.
4. While a setting is flashing, use (A) (+) and (C) (-) to change it.
 - When setting the alarm time using the 12-hour format, take care to set the time correctly as a.m. (no indicator) or p.m. (P indicator).
5. Press (E) to exit the setting screen.

Alarm Operation

The alarm sounds in all modes at the preset time for about 10 seconds, or until you stop it by pressing any button.

To test the alarm

In the Alarm Mode, hold down (A) to sound the alarm.

To turn an alarm and the Hourly Time Signal on and off

1. In the Alarm Mode, use (A) and (C) to select an alarm or the Hourly Time Signal.
 2. When the alarm or the Hourly Time Signal you want is selected, press (B) to turn it on (ON) and off (OFF).
 - Indicates alarm is ON.
 - 🔔 Indicates Hourly Time Signal is ON.
- The alarm on indicator (■■■) and the Hourly Time Signal on indicator (🔔) are shown on the display in all modes while these functions are turned on.
 - If any alarm is on, the alarm on indicator is shown on the display in all modes.

Illumination

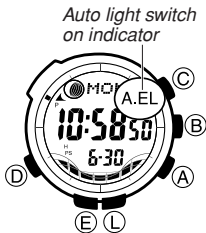

The display of the watch is illuminated using an EL (electro-luminescent) panel for easy reading in the dark. The watch's auto light switch turns on illumination automatically when you angle the watch towards your face.

- The auto light switch must be turned on (indicated by the auto light switch on indicator) for it to operate.
- See “Illumination Precautions” (page E-137) for other important information about using illumination.

To turn on illumination manually

Press (L) in any mode to illuminate the display for about one second.

- The above operation turns on illumination regardless of the current auto light switch setting.
- Illumination is disabled during time calibration signal reception, while configuring sensor measurement mode settings, and during bearing sensor calibration.

About the Auto Light Switch

Turning on the auto light switch causes illumination to turn on, whenever you position your wrist as described below in any mode.

Note that this watch features a “Full Auto EL Light”, so the auto light switch operates only when available light is below a certain level. It does not illuminate the display under bright light.

- The auto light switch is always disabled, regardless of its on/off setting, when any one of the following conditions exists.

While an alarm is sounding

During sensor measurement

While a bearing sensor calibration operation is being performed in the Digital Compass Mode

While a receive operation is in progress in the Receive Mode

During tide data calculation

Moving the watch to a position that is parallel to the ground and then tilting it towards you more than 40 degrees causes illumination to turn on.

- Wear the watch on the outside of your wrist.

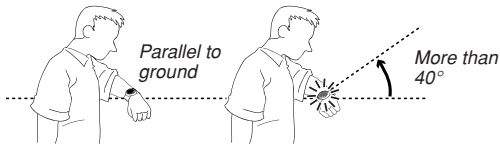

Warning!

- **Always make sure you are in a safe place whenever you are reading the display of the watch using the auto light switch. Be especially careful when running or engaged in any other activity that can result in accident or injury. Also take care that sudden illumination by the auto light switch does not startle or distract others around you.**

- When you are wearing the watch, make sure that its auto light switch is turned off before riding on a bicycle or operating a motorcycle or any other motor vehicle. Sudden and unintended operation of the auto light switch can create a distraction, which can result in a traffic accident and serious personal injury.

To turn the auto light switch on and off

In the Timekeeping Mode, hold down \textcircled{L} for about three seconds to toggle the auto light switch on (**A.EL** displayed) and off (**A.EL** not displayed).

- The auto light switch on indicator (**A.EL**) is on the display in all modes while the auto light switch is turned on.
- The auto light switch turns off automatically whenever battery power drops to Level 4 (page E-107).
- Illumination may not turn on right away if you raise the watch to your face while a barometric pressure or altitude measurement operation is in progress.

Questions & Answers

Question: What causes incorrect direction readings?

Answer:

- Incorrect bidirectional calibration. Perform bidirectional calibration (page E-44).
- Nearby source of strong magnetism, such as a household appliance, a large steel bridge, a steel beam, overhead wires, etc., or an attempt to perform direction measurement on a train, boat, etc. Move away from large metal objects and try again. Note that digital compass operation cannot be performed inside a train, boat, etc.

Question: What causes different direction readings to produce different results at the same location ?

Answer: Magnetism generated by nearby high-tension wires is interfering with detection of terrestrial magnetism. Move away from the high-tension wires and try again.

Question: Why am I having problems taking direction readings indoors ?

Answer: A TV, personal computer, speakers, or some other object is interfering with terrestrial magnetism readings. Move away from the object causing the interference or take the direction reading outdoors. Indoor direction readings are particularly difficult inside ferro-concrete structures. Remember that you will not be able to take direction readings inside of trains, airplanes, etc.

Question: How can the barometer be used to predict weather?

Answer: Barometric pressure indicates changes in the atmosphere, and by monitoring these changes you can predict the weather with reasonable accuracy. Rising atmospheric pressure indicates good weather, while falling pressure indicates deteriorating weather conditions.

The barometric pressures that you see in the newspaper and on the TV weather report are measurements corrected to values measured at 0 m sea level.

Question: How does the altimeter work?

Answer: Generally, air pressure and temperature decrease as altitude increases. This watch bases its altitude measurements on International Standard Atmosphere (ISA) values stipulated by the International Civil Aviation Organization (ICAO). These values define relationships between altitude, air pressure, and temperature.

Altitude	Air Pressure	Temperature
4000 m	616 hPa	-11°C
3500 m	701 hPa	-4.5°C
3000 m		
2500 m	795 hPa	2°C
2000 m	899 hPa	8.5°C
1500 m		
1000 m	1013 hPa	15°C
500 m		
0 m		

Notes: About 8 hPa per 100 m (between 4000m and 3000m); About 9 hPa per 100 m (between 3000m and 2000m); About 10 hPa per 100 m (between 2000m and 1000m); About 11 hPa per 100 m (between 1000m and 500m); About 12 hPa per 100 m (between 500m and 0m); About 6.5°C per 1000 m (overall temperature gradient).

Source: International Civil Aviation Organization

- Note that the following conditions will prevent you from obtaining accurate altitude readings:

When air pressure changes because of changes in the weather

Extreme temperature changes

When the watch itself is subjected to strong impact

There are two standard methods of expressing altitude: Absolute altitude and relative altitude. Absolute altitude expresses an absolute height above sea level. Relative altitude expresses the difference between the height of two different places.

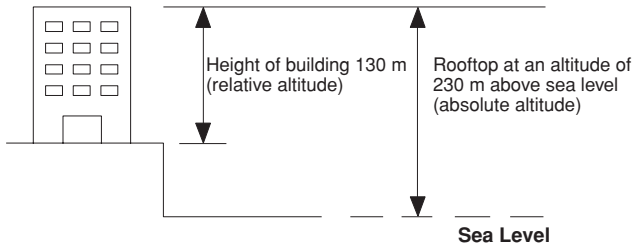

Precautions Concerning Simultaneous Measurement of Altitude and Temperature

Though you can perform altitude and temperature measurements at the same time, you should remember that each of these measurements requires different conditions for best results. With temperature measurement, it is best to remove the watch from your wrist in order to eliminate the effects of body heat. In the case of altitude measurement, on the other hand, it is better to leave the watch on your wrist, because doing so keeps the watch at a constant temperature, which contributes to more accurate altitude measurements.

- To give altitude measurement priority, leave the watch on your wrist or in any other location where the temperature of the watch is kept constant.
- To give temperature measurement priority, remove the watch from your wrist and allow it to hang freely from your bag or in another location where it is not exposed to direct sunlight. Note that removing the watch from your wrist can affect pressure sensor readings momentarily (page E-140).

Power Supply

This watch is equipped with a solar cell and a special rechargeable battery (secondary battery) that is charged by the electrical power produced by the solar cell. The illustration shown below shows how you should position the watch for charging.

Example: Orient the watch so its face is pointing at a light source.

- The illustration shows how to position a watch with a resin band.
- Note that charging efficiency drops when any part of the solar cell is blocked by clothing, etc.
- You should try to keep the watch outside of your sleeve as much as possible. Charging is reduced significantly if the face is covered only partially.

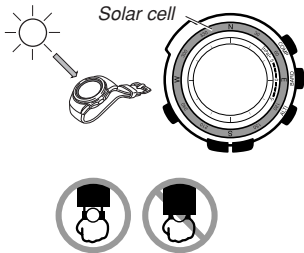

Important!



- Storing the watch for long periods in an area where there is no light or wearing it in such a way that it is blocked from exposure to light can cause rechargeable battery power to run down. Be sure that the watch is exposed to bright light whenever possible.
- This watch uses a special rechargeable battery to store power produced by the solar cell, so regular battery replacement is not required. However, after very long use, the rechargeable battery may lose its ability to achieve a full charge. If you experience problems getting the special rechargeable battery to charge fully, contact your dealer or CASIO distributor about having it replaced.
- Never try to remove or replace the watch's special battery yourself. Use of the wrong type of battery can damage the watch.
- All data stored in memory is deleted, and the current time and all other settings return to their initial factory defaults whenever battery power drops to Level 5 (page E-107) and when you have the battery replaced.
- Turn on the watch's Power Saving function (page E-132) and keep it in an area normally exposed to bright light when storing it for long periods. This helps to keep the rechargeable battery from going dead.

Battery Power Indicators

The battery power indicator on the display shows you the current status of the rechargeable battery's power.



Battery power indicator

Level	Battery Power Indicator	Function Status
1	H	All functions enabled.
2	M	All functions enabled.
3	 (Charge Soon Alert)	Auto and manual receive, illumination, beeper, and sensor operation disabled.
4	 (Charge Soon Alert)	Except for timekeeping and the C (charge) indicator, all functions and display indicators disabled.
5		All functions disabled.

- The flashing **LOW** indicator at Level 3 tells you that battery power is very low, and that exposure to bright light for charging is required as soon as possible.
- At Level 5, all functions are disabled and settings return to their initial factory defaults. Once the battery reaches Level 2 (indicated by **M** indicator) after falling to Level 5, reconfigure the current time, date, and other settings.
- Display indicators reappear as soon as the battery is charged from Level 5 to Level 2.
- Leaving the watch exposed to direct sunlight or some other very strong light source can cause the battery power indicator to show a reading temporarily that is higher than the actual battery level. The correct battery level should be indicated after a few minutes.



- Performing multiple sensor, illumination, or beeper operations during a short period may cause all of the battery indicators (**L**, **M**, **H**) to flash on the display. Illumination, alarm, countdown timer alarm, hourly time signal, and sensor operations will be disabled until battery power recovers.
After some time, battery power will recover and battery indicators (**L**, **M**, **H**) will disappear, indicating that the above functions are enabled again.
- Even if battery power is at Level 1 or Level 2, the Digital Compass Mode, Barometer/Thermometer Mode, or Altimeter Mode sensor may be disabled if there is not enough voltage available to power it sufficiently. This is indicated by battery indicators (**L**, **M**, **H**) on the display.
- If battery indicators (**L**, **M**, **H**) appears frequently, it probably means that remaining battery power is low. Leave the watch in bright light to allow it to charge.

Charging Precautions

Certain charging conditions can cause the watch to become very hot. Avoid leaving the watch in the areas described below whenever charging its rechargeable battery. Also note that allowing the watch to become very hot can cause its liquid crystal display to black out. The appearance of the LCD should become normal again when the watch returns to a lower temperature.

Warning!

Leaving the watch in bright light to charge its rechargeable battery can cause it to become quite hot. Take care when handling the watch to avoid burn injury. The watch can become particularly hot when exposed to the following conditions for long periods.

- On the dashboard of a car parked in direct sunlight
- Too close to an incandescent lamp
- Under direct sunlight

Charging Guide

After a full charge, timekeeping remains enabled for up to about five months.

- The following table shows the amount of time the watch needs to be exposed to light each day in order to generate enough power for normal daily operations.

Exposure Level (Brightness)	Approximate Exposure Time
Outdoor Sunlight (50,000 lux)	5 minutes
Sunlight Through a Window (10,000 lux)	24 minutes
Daylight Through a Window on a Cloudy Day (5,000 lux)	48 minutes
Indoor Fluorescent Lighting (500 lux)	8 hours

- For details about the battery operating time and daily operating conditions, see the “Power Supply” section of the Specifications (page E-146).
- Stable operation is promoted by frequent exposure to light.

Recovery Times

The table below shows the amount exposure that is required to take the battery from one level to the next.

Exposure Level (Brightness)	Approximate Exposure Time				
	Level 5	Level 4	Level 3	Level 2	Level 1
Outdoor Sunlight (50,000 lux)	1 hour			12 hours	4 hours
Sunlight Through a Window (10,000 lux)	3 hours			58 hours	16 hours
Daylight Through a Window on a Cloudy Day (5,000 lux)	5 hours			119 hours	33 hours
Indoor Fluorescent Lighting (500 lux)	52 hours			-----	-----

- The above exposure time values are all for reference only. Actual required exposure times depend on lighting conditions.

Timekeeping

Use the Timekeeping Mode to set and view the current time and date.

- In the Timekeeping Mode, an indicator moves along the ring around the display as seconds advance.
- The tide graph (page E-125) shows tidal movements for the current date in accordance with the current time as kept in the Timekeeping Mode.
- The Moon phase indicator (page E-122) shows the current Moon phase in accordance with the current date as kept in the Timekeeping Mode.
- In the Timekeeping Mode, you can press **(E)** to toggle the display contents as shown below.

Day of the Week Screen

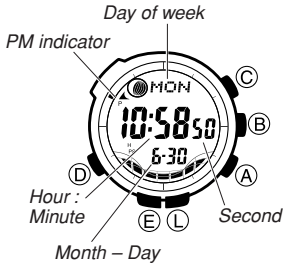

Press (E).

Barometric Pressure Graph Screen

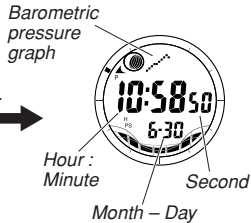

Read This Before You Set the Time and Date!

This watch is preset with a number of city codes, each of which represents the time zone where that city is located. When setting the time, it is important that you first select the correct city code for your Home City (the city where you normally use the watch). If your location is not included in the preset city codes, select the preset city code that is in the same time zone as your location.

- Note that all of the times for the World Time Mode city codes (page E-90) are displayed in accordance with the time and date settings you configure in the Timekeeping Mode.

To set the time and date manually

1. In the Timekeeping Mode, hold down (E) until the city code starts to flash, which indicates the setting screen.
2. Use (A) and (C) to select the city code you want.
 - Make sure you select your Home City code before changing any other setting.
 - For full information on city codes, see the “City Code Table” at the back of this manual.

3. Press **(D)** to move the flashing in the sequence shown below to select the other settings.

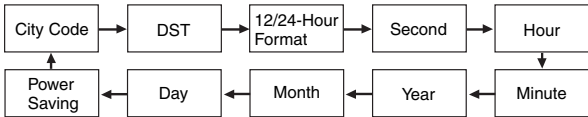

- The following steps explain how to configure timekeeping settings only.
4. When the timekeeping setting you want to change is flashing, use **(A)** and/or **(C)** to change it as described below.

Screen	To do this:	Do this:
TYO	Change the city code	Use (A) (east) and (C) (west).
OFF	Cycle between Auto DST (AUTO), Daylight Saving Time (ON) and Standard Time (OFF).	Press (A) .
24H	Toggle between 12-hour (12H) and 24-hour (24H) timekeeping.	Press (A) .

Screen	To do this:	Do this:
50	Reset the seconds to 00	Press (A).
P 10:58	Change the hour or minute	Use (A) (+) and (C) (-).
2008	Change the year	
6-30	Change the month or day	

5. Press (E) to exit the setting screen.

Note

- Auto DST (**AUTO**) can be selected only while LON, PAR, BER, ATH, NYC, CHI, DEN, LAX, ANC, HNL, TYO, SEL, or HKG is selected as the Home City code. For more information, see “Daylight Saving Time (DST)” below.

- You also need to enter the Timekeeping Mode in order to configure the following settings.

Power saving on/off (“To turn Power Saving on and off” on page E-132)

Daylight Saving Time (DST)

Daylight Saving Time (summer time) advances the time setting by one hour from Standard Time. Remember that not all countries or even local areas use Daylight Saving Time.

The time calibration signals transmitted from Mainflingen (Germany), Anthorn (England), or Fort Collins (the United States) include both Standard Time and DST data. When the Auto DST setting is turned on, the watch switches between Standard Time and DST (summer time) automatically in accordance with the signals.

- Though the time calibration signal transmitted by the Fukushima and Fukuoka/Saga, Japan transmitters include summer time data, summer time currently is not implemented in Japan (as of 2008).

- The default DST setting is Auto DST (**AUTO**) whenever you select **LON**, **PAR**, **BER**, **ATH**, **NYC**, **CHI**, **DEN**, **LAX**, **ANC**, **HNL**, or **TYO** as your Home City code.
- If you experience problems receiving the time calibration signal in your area, it probably is best to switch between Standard Time and Daylight Saving Time (summer time) manually.

To change the Daylight Saving Time (summer time) setting

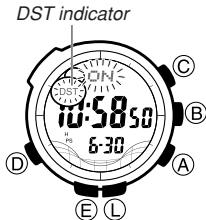

1. In the Timekeeping Mode, hold down (E) until the city code starts to flash, which indicates the setting screen.
2. Press (D) and the DST setting screen appears.
3. Use (A) to cycle through the DST settings in the sequence shown below.

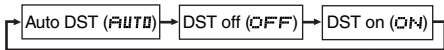

- If you change your Home City to one that is within the same transmitter area, the current DST setting will be retained. If you change to a city that is outside your current transmitter area, DST will be turned off automatically.
Transmitter area city codes
 - **HKG, SEL, and TYO**
 - **LAX, DEN, CHI, NYC, ANC, and HNL**
 - **LON, PAR, BER, and ATH**
 - All other city codes
4. When the setting you want is selected, press **(E)** to exit the setting screen.
- The **DST** indicator appears to indicate that Daylight Saving Time is turned on.

Reference

This section contains more detailed and technical information about watch operation. It also contains important precautions and notes about the various features and functions of this watch.

Moon Phases and Moon Age

The Moon goes through a regular 29.53-day cycle. During each cycle, the Moon appears to wax and wane as the relative positioning of the Earth, Moon, and Sun changes. The greater the angular distance between the Moon and the Sun,* the more we see illuminated.

** The angle to the Moon in relation to the direction at which the Sun is visible from the Earth.*

This watch performs a rough calculation of the current Moon age starting from day 0 of the moon age cycle. Since this watch performs calculations using integer values only (no fractions), the margin for error of the displayed Moon age is ± 1 day.









Moon Phase Indicator









Moon Phase indicator



The Moon phase indicator of this watch indicates the current phase of the Moon as shown below. It is based on the view of the left side of the moon at meridian transit from the northern hemisphere of the Earth. If the appearance of the Moon phase indicator is reversed from the actual Moon as viewed from your location, you can use the procedure under “To reverse the displayed Moon phase” (page E-80) to change the indicator.

(part you cannot see) ——— Moon phase (part you can see)

Moon Phase Indicator								
Moon Age	28.7-29.5 0.0-0.9	1.0-2.7	2.8-4.6	4.7-6.4	6.5-8.3	8.4-10.1	10.2-12.0	12.1-13.8
Moon Phase	New Moon				First Quarter (Waxing)			



Moon Phase Indicator								
Moon Age	13.9-15.7	15.8-17.5	17.6-19.4	19.5-21.2	21.3-23.1	23.2-24.9	25.0-26.8	26.9-28.6
Moon Phase	Full Moon				Last Quarter (Waning)			

Tidal Movements

Tides are the periodic rise and fall of the water of oceans, seas, bays, and other bodies of water caused mainly by the gravitational interactions between the Earth, Moon and Sun. Tides rise and fall about every six hours. The Tide Graph of this watch indicates tidal movement based on the Moon's transit over a meridian and the lunital interval. The Tide Graph calculates and graphically represents current tide conditions in your Home City or a port city in the vicinity of the Home City based on longitudes, lunar day length, and lunital interval preset in watch memory, and on high tide times specified by you.

Tide Graph

The Tide Graph graphically represents the current tide condition using one of three patterns that represent spring tide, intermediate tide, and neap tide, as shown below.

Tide Name	Graph	Description
Spring Tide		Large difference between high tide and low tide. Occurs a few days before and after a New Moon and Full Moon.
Intermediate Tide		Medium difference between high tide and low tide.
Neap Tide		Small difference between high tide and low tide. Occurs a few days before and after the first quarter and last quarter of a half moon.

- The Tide Graph flashes as shown below to indicate the tide range.

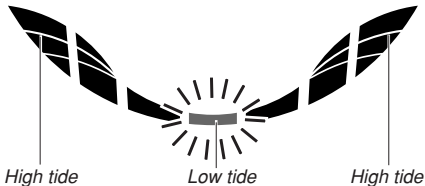

- The segments on either end of the Tide Graph flash during high tide.

Lunitidal Interval

Theoretically, high tide is at the Moon's transit over the meridian and low tide is about six hours later. Actual high tide occurs somewhat later, due to factors such as viscosity, friction, and underwater topography. Both the time differential between the Moon's transit over the meridian until high tide and the time differential between the Moon's transit over the meridian until low tide are known as the "lunitidal interval".

Auto Return Features

- The watch returns to the Timekeeping Mode automatically if you do not perform any button operation for two or three minutes in the Tide/Moon Data, Alarm, Data Recall, Receive, Digital Compass, or Barometer/Thermometer Mode.
- If you do not perform any button operation while in the Altimeter Mode, the watch returns to the Timekeeping Mode automatically after nine or 10 hours.
- If you leave a screen with flashing digits on the display for two or three minutes without performing any operation, the watch exits the setting screen automatically.

Initial Screens

When you enter the World Time or Alarm Mode, the data you were viewing when you last exited the mode appears first.

Scrolling

The **(A)** and **(C)** buttons are used on the setting screen to scroll through data on the display. In most cases, holding down these buttons during a scroll operation scrolls through the data at high speed.

Sensor Malfunction Indicator

Subjecting the watch to strong impact can cause sensor malfunction or improper contact of internal circuitry. When this happens, **ERR** (error) will appear on the display and sensor operations will be disabled.

- If **ERR** appears while a measurement operation is being performed in a sensor mode, restart the measurement. If **ERR** appears on the display again, it can mean there is something wrong with the sensor.
- Even if battery power is at Level 1 or Level 2, the Digital Compass Mode, Barometer/Thermometer Mode, or Altimeter Mode sensor may be disabled if there is not enough voltage available to power it sufficiently. In this case, **ERR** will appear on the display. This does not indicate malfunction, and sensor operation should resume once battery voltage returns to its normal level.
- If **ERR** keeps appearing during measurement, it could mean there is a problem with the applicable sensor.

Whenever you have a sensor malfunction, be sure to take the watch to your original dealer or nearest authorized CASIO distributor as soon as possible.

Button Operation Tone

Mute indicator

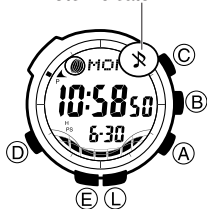

The button operation tone sounds any time you press one of the watch's buttons. You can turn the button operation tone on or off as desired.

- Even if you turn off the button operation tone, the alarm, Hourly Time Signal, and Countdown Timer Mode alarm all operate normally.

To turn the button operation tone on and off

In any mode (except when a setting screen is on the display), hold down (D) to toggle the button operation tone on (⌂ not displayed) and off (⌂ displayed).

- Since the (D) button also is the mode change button, holding it down to turn the button operation on or off also causes the watch's current mode to change.
- The ⌂ indicator is displayed in all modes when the button operation tone is turned off.

Power Saving

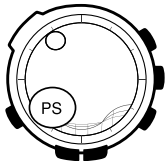

When turned on, Power Saving enters a sleep state automatically whenever the watch is left for a certain period in an area where it is dark. The table below shows how watch functions are affected by Power Saving.

- There actually are two sleep state levels: “display sleep” and “function sleep”.

Elapsed Time in Dark	Display	Operation
60 to 70 minutes (Display Sleep)	Blank, with PS flashing	Display is off, but all functions are enabled.
6 or 7 days (Function Sleep)	Blank, with PS not flashing	All functions are disabled, but timekeeping is maintained.

- Wearing the watch inside the sleeve of clothing can cause it to enter the sleep state.
- The watch will not enter the sleep state while the digital time is between 6:00 AM and 9:59 PM. If the watch is already in the sleep state when the digital time reaches 6:00 AM, however, it will remain in the sleep state.
- The watch will not enter the sleep state while it is in the Digital Compass, Barometer/Thermometer, Altimeter, Receive, Countdown Timer, or Stopwatch Mode. When the watch is left in any mode besides the Countdown Timer and Stopwatch Mode, it will return to the Timekeeping Mode automatically after a specific amount of time (page E-127). Then if left in the dark for the elapsed time indicated in the table above, the watch will enter the sleep state.

To recover from the sleep state

Perform any one of the following operations.

- Move the watch to a well-lit area. It can take up to two seconds for the display to turn on.
- Press any button.
- Angle the watch towards your face for reading (page E-97).

To turn Power Saving on and off

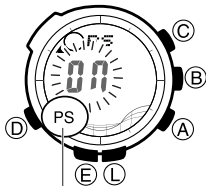

Power Saving on indicator

1. In the Timekeeping Mode, hold down (E) until the city code starts to flash, which indicates the setting screen.
 2. Press (D) nine times until the Power Saving on/off screen appears.
 3. Press (A) to toggle Power Saving on (ON) and off (OFF).
 4. Press (E) to exit the setting screen.
- The Power Saving on indicator (PS) is on the display in all modes while Power Saving is turned on.

Radio-controlled Atomic Timekeeping Precautions

- Strong electrostatic charge can result in the wrong time being set.
- The time calibration signal bounces off the ionosphere. Because of this, such factors as changes in the reflectivity of the ionosphere, as well as movement of the ionosphere to higher altitudes due to seasonal atmospheric changes or the time of day may change the reception range of the signal and make reception temporarily impossible.
- Even if the time calibration signal is received properly, certain conditions can cause the time setting to be off by up to one second.
- The current time setting in accordance with the time calibration signal takes priority over any time settings you make manually.
- The watch is designed to update the date and day of the week automatically for the period January 1, 2000 to December 31, 2099. Setting of the date by the time calibration signal cannot be performed starting from January 1, 2100.
- This watch can receive signals that differentiate between leap years and non-leap years.

- Though this watch is designed to receive both time data (hour, minute, second) and date data (year, month, day), certain signal conditions can limit reception to time data only.
- If you are in an area where proper time calibration signal reception is impossible, the watch keeps the time with the precision noted in “Specifications”.
- If you have problems with proper time calibration signal reception or if the time setting is wrong after signal reception, check your current city code, DST (summer time) (page E-115), and auto receive settings (page E-29).
- The Home City setting reverts to the initial default of T'Y☐ (Tokyo) whenever the battery power level drops to Level 5 or when you have the rechargeable battery replaced. If this happens, change the Home City to the setting you want (page E-14).

Transmitters

The time calibration signal received by this watch depends on the currently selected Home City code (page E-14).

- When a U.S. time zone is selected, the watch receives the time calibration signal transmitted from the United States (Fort Collins).
- When a Japanese time zone is selected, the watch receives the time calibration signal transmitted from Japan (Fukushima and Fukuoka/Saga).
- When a European time zone is selected, the watch receives the time calibration signals transmitted from Germany (Mainflingen) and England (Anthorn).
- When your Home City is **LON**, **PAR**, **BER**, or **ATH** (which can receive both the Anthorn and Mainflingen signals), the watch first tries to pick up the signal it last successfully received. If that fails, it tries the other signal. For the first receive after you select your Home City, the watch tries the nearest signal first (Anthorn for **LON**, Mainflingen for **PAR**, **BER**, and **ATH**).

Timekeeping

- Resetting the seconds to **00** while the current count is in the range of 30 to 59 causes the minutes to be increased by 1. In the range of 00 to 29, the seconds are reset to **00** without changing the minutes.
- With the 12-hour format, the **P** (PM) indicator appears on the display for times in the range of noon to 11:59 p.m. and no indicator appears for times in the range of midnight to 11:59 a.m.
- With the 24-hour format, times are displayed in the range of 0:00 to 23:59, without any indicator.
- The 12-hour/24-hour timekeeping format you select in the Timekeeping Mode is applied in all modes.
- The watch's built-in full automatic calendar makes allowances for different month lengths and leap years. Once you set the date, there should be no reason to change it except when battery power drops to Level 5 (page E-107).
- The times for the Timekeeping Mode and all the city codes of the World Time Mode are calculated in accordance with each city's UTC offset.
- The UTC offset is a value that indicates the time difference between a reference point in Greenwich, England and the time zone where a city is located.

- The letters “UTC” is the abbreviation for “Coordinated Universal Time”, which is the world-wide scientific standard of timekeeping. It is based upon carefully maintained atomic (cesium) clocks that keep time accurately to within microseconds. Leap seconds are added or subtracted as necessary to keep UTC in sync with the Earth’s rotation.

Illumination Precautions

- The electro-luminescent panel that provides illumination loses power after very long use.
- Illumination may be hard to see when viewed under direct sunlight.
- Illumination turns off automatically whenever an alarm sounds.
- The watch may emit an audible sound whenever the display is illuminated. This is due to vibration of the EL panel used for illumination, and does not indicate malfunction.
- Frequent use of illumination runs down the battery.

Auto light switch precautions

- The auto light switch is turned off automatically whenever battery power is at Level 4 (page E-107).

- Wearing the watch on the inside of your wrist, movement of your arm, or vibration of your arm can cause frequent activation of the auto light switch and illumination of the display. To avoid running down the battery, turn off the auto light switch whenever engaging in activities that might cause frequent illumination of the display.
- Note that wearing the watch under your sleeve while the auto light switch is turned on can cause frequent illumination of the display and can run down the battery.

*More than 15 degrees
too high*



- Illumination may not turn on if the face of the watch is more than 15 degrees above or below parallel. Make sure that the back of your hand is parallel to the ground.
 - Illumination turns off in about one second, even if you keep the watch pointed towards your face.
- Static electricity or magnetic force can interfere with proper operation of the auto light switch. If illumination does not turn on, try moving the watch back to the starting position (parallel with the ground) and then tilt it back towards your face again. If this does not work, drop your arm all the way down so it hangs at your side, and then bring it back up again.

- Under certain conditions, illumination does not turn on until about one second after you turn the face of the watch towards you. This does not necessarily indicate malfunction.
- You may notice a very faint clicking sound coming from the watch when it is shaken back and forth. This sound is caused by mechanical operation of the auto light switch, and does not indicate a problem with the watch.

Barometer and Thermometer Precautions

- The pressure sensor built into this watch measures changes in air pressure, which you can then apply to your own weather predictions. It is not intended for use as a precision instrument in official weather prediction or reporting applications.
- Sudden temperature changes can affect pressure sensor readings.
- Temperature measurements are affected by your body temperature (while you are wearing the watch), direct sunlight, and moisture. To achieve a more accurate temperature measurement, remove the watch from your wrist, place it in a well ventilated location out of direct sunlight, and wipe all moisture from the case. It takes approximately 20 to 30 minutes for the case of the watch to reach the actual surrounding temperature.

Pressure Sensor and Temperature Sensor Calibration

The pressure sensor and temperature sensor built into the watch are calibrated at the factory and normally require no further adjustment. If you notice serious errors in the pressure readings and temperature readings produced by the watch, you can calibrate the sensor to correct the errors.

Important!

- Incorrectly calibrating the barometric pressure sensor can result in incorrect readings. Before performing the calibration procedure, compare the readings produced by the watch with those of another reliable and accurate barometer.
- Incorrectly calibrating the temperature sensor can result in incorrect readings. Carefully read the following before doing anything.

Compare the readings produced by the watch with those of another reliable and accurate thermometer.

If adjustment is required, remove the watch from your wrist and wait for 20 or 30 minutes to give the temperature of the watch time to stabilize.

To calibrate the pressure sensor and the temperature sensor

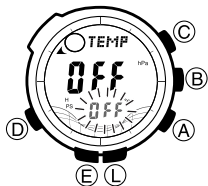

1. Press (B) to enter the Barometer/ Thermometer Mode (page E-11).
2. In the Barometer/Thermometer Mode, hold down (E) for about two seconds until either **OFF** or the reference temperature value starts to flash. This is the setting screen.
 - If you want to calibrate the barometric pressure sensor, press (D) to move the flashing to the middle display area. This is the pressure sensor calibration screen.
 - At this time, **OFF** or the barometric pressure value should be flashing on the display.



3. Use Ⓐ (+) and Ⓒ (−) to set the calibration value in the units shown below.

Temperature 0.1°C

Barometric Pressure 1 hPa

- “**OFF**” is displayed while the reference temperature value and barometric pressure value are zero (0).
 - Pressing Ⓐ and Ⓒ at the same time returns to the factory calibration (**OFF**).
4. Press Ⓔ to return to the Barometer/Thermometer Mode screen.

Specifications

Accuracy at normal temperature: ± 20 seconds a month (with no signal calibration)

Timekeeping: Hour, minute, second, p.m. (P), month, day, day of the week

Time format: 12-hour and 24-hour

Calendar system: Full Auto-calendar pre-programmed from the year 2000 to 2099

Other: 2 display formats (Day of the Week, Barometric Pressure Graph); Home City code (can be assigned one of 33 city codes); Standard Time / Daylight Saving Time (summer time)

Time Calibration Signal Reception: Auto receive 6 times a day (Remaining auto receives cancelled as soon as one is successful); Manual receive; Receive Mode

Receivable Time Calibration Signals: Mainflingen, Germany (Call Sign: DCF77, Frequency: 77.5 kHz);

Anthorn, England (Call Sign: MSF, Frequency: 60.0 kHz); Fort Collins, Colorado, the United

States (Call Sign: WWVB, Frequency: 60.0 kHz); Fukushima, Japan (Call Sign: JJY, Frequency:

40.0 kHz); Fukuoka/Saga, Japan (Call Sign: JJY, Frequency: 60.0 kHz)

Digital Compass: 20 seconds continuous measurement; 16 directions; Angle value 0° to 359° ; Four direction pointers; Calibration (bidirectional, northerly); Magnetic declination correction

Barometer:

Measurement and display range: 260 to 1,100 hPa

Display unit: 1 hPa

Measurement timing: Daily from midnight, at two hour intervals (12 times per day); Every five seconds in the Barometer/Thermometer Mode

Other: Calibration; Manual measurement (button operation); Barometric pressure graph

Thermometer:

Measurement and display range: -10.0 to 60.0°C

Display unit: 0.1°C

Measurement timing: Every five seconds in the Barometer/Thermometer Mode

Other: Calibration; Manual measurement (button operation)

Altimeter:

Measurement range: -700 to 10,000 m without reference altitude

Display range: -10,000 to 10,000 m

Negative values can be caused by readings produced based on a reference altitude or due to atmospheric conditions.

Display unit: 5 m

Current Altitude Data: 5-second interval for first 3 minutes followed by 2-minute interval for next 9 or 10 hours

Altitude Memory Data: 24 altitude records and one high altitude record

Altitude records: Pressing a button records the current altitude value, along with the date (month-day) of the reading.

High altitude record: Automatically records the highest altitude value measured in the Altimeter Mode to date, along with the date (month-day) of the reading.

Other: Reference altitude setting; Altitude graph

Bearing Sensor Precision:

Direction: Within $\pm 10^\circ$

Values are guaranteed for a temperature range of -10°C to 40°C .

North pointer: Within ± 2 digital segments

Pressure Sensor Precision:

	Conditions (Altitude)	Altimeter	Barometer
Fixed temperature	0 to 6000 m	\pm (altitude differential \times 3% + 30 m) m	\pm (pressure differential \times 3% + 3 hPa) hPa
	6000 to 10000 m	\pm (altitude differential \times 3% + 45 m) m	
Effect of variable temperature	0 to 6000 m	\pm 80 m every 10°C	\pm 6 hPa every 10°C
	6000 to 10000 m	\pm 120 m every 10°C	

- Values are guaranteed for a temperature range of -10°C to 40°C .
- Precision is lessened by strong impact to either the watch or the sensor, and by temperature extremes.

Temperature Sensor Precision:

$\pm 2^{\circ}\text{C}$ in range of -10°C to 60°C

Tide/Moon Data:

Moon phase indicator for specific date; Tide level for specific date and time

Other: High tide time adjustment; Moon phase reversal

Countdown Timer:

Measuring unit: 1 second

Countdown range: 60 minutes

Setting ranges: Countdown start time (1 to 60 minutes, 1-minute increments); Reset time (1 to 5 minutes, 1-minute increments)

Other: Progress beeper

Stopwatch:

Measuring unit: 1/100 second

Measuring capacity: 23:59' 59.99"

Measuring modes: Elapsed time, split time, two finishes

Alarms: 5 Daily alarms; Hourly time signal

World Time: 33 cities (29 time zones)

Other: Daylight Saving Time/Standard Time

Illumination: EL Backlight (electro-luminescent panel); Auto Light Switch (Full Auto EL Light operates only in the dark)

Other: Battery power indicator; Power Saving; Low-temperature resistance (-10°C); Button operation tone on/off

Power Supply: Solar cell and one rechargeable battery

Approximate battery operating time: 5 months (from full charge to Level 4) under the following conditions:

- Watch not exposed to light
- Internal timekeeping
- Display on 18 hours per day, sleep state 6 hours per day
- 1 illumination operation (1.5 seconds) per day
- 10 seconds of alarm operation per day
- 10 digital compass operations per week
- 10 hours of altimeter measurement at 2-minutes interval, once per month
- 2 hours of barometric pressure measurement per day
- 6 minutes of signal reception per day

Frequent use of illumination runs down the battery. Particular care is required when using the auto light switch (page E-137).

20 months when the watch is left in the sleep state (display off) after a full charge.

Operating Precautions

Water Resistance

- The following applies to watches with WATER RESIST or WATER RESISTANT marked on the back cover.

Marking	On watch front or on back cover	Water Resistance Under Daily Use	Enhanced Water Resistance Under Daily Use		
			5 Atmospheres	10 Atmospheres	20 Atmospheres
		No BAR mark	5BAR	10BAR	20BAR
Example of Daily Use	Hand washing, rain	Yes	Yes	Yes	Yes
	Water-related work, swimming	No	Yes	Yes	Yes
	Windsurfing	No	No	Yes	Yes
	Skin diving	No	No	Yes	Yes

- Do not use this watch for scuba diving or other types of diving that requires air tanks.
- Watches that do not have WATER RESIST or WATER RESISTANT marked on the back cover are not protected against the effects of sweat. Avoid using such a watch under conditions where it will be exposed to large amounts of sweat or moisture, or to direct splashing with water.
- Even if a watch is water-resistant, do not operate its buttons or crown while it is submerged in water or wet.
- Even if a watch is water-resistant, avoid wearing it in the bath or in areas where detergents (soap, shampoo, etc.) are being used. Such conditions can reduce water resistance.
- After submersion in seawater, use plain water to rinse all salt and dirt from the watch.

- In order to maintain water resistance, have the gaskets of your watch replaced periodically (about once every two or three years).
- A trained technician will know how to check your watch for proper water resistance whenever you have its battery replaced. Battery replacement requires the use of special tools. Always request battery replacement from your original retailer or from an authorized CASIO Service Center.
- Some water-resistant watches come with fashionable leather bands. Avoid swimming, washing, or any other activity that causes direct exposure of a leather band to water.
- The inside surface of the watch glass may fog when the watch is exposed to a sudden drop in temperature. No problem is indicated if the fogging clears up relatively quickly. If the fogging does not clear or if water has gotten into the watch, take the watch in for repair immediately.
- Continued use of the watch with water inside can result in damage to electronic and mechanical components, the face of the watch, etc.

Band

- Tightening the band too tightly can cause you to sweat and make it hard for air to pass under the band, which can lead to skin irritation. Do not fasten the band too tightly. There should be enough room between the band and your wrist so you can insert your finger.
- Deterioration, rust, or corrosion of the band can cause it to break, which may result in the watch falling off your wrist and becoming lost. Be sure to take good care of the band and keep it clean. Should you notice any breakage, discoloration, looseness or other problem with the band, immediately contact your original retailer or an authorized CASIO Service Center to have it checked, repaired, or replaced. Note that you will be charged for any repair or replacement of the band.

Temperature

- Never leave the watch on the dashboard of a car, near a heater, or in any other location that is subject to very high temperatures. Do not leave the watch where it will be exposed to very low temperatures, either. Temperature extremes can cause the watch to lose or gain time, to stop, or otherwise malfunction.
- Leaving the watch in an area hotter than +60°C for long periods can lead to problems with its LCD. The LCD may become difficult to read at temperatures lower than 0°C and greater than +40°C.

Impact

- Your watch is designed to withstand impact incurred during normal daily use and light activity such as playing catch, tennis, etc. Dropping the watch or otherwise subjecting it to strong impact, however, can lead to malfunction.

Note that watches with shock-resistant designs (G-SHOCK, Baby-G, G-ms) can be worn while operating a chain saw or engaging in other activities that generate strong vibration, or while engage in strenuous sports activities (motocross, etc.).

Magnetism

- Though your watch normally is not affected by magnetism, very strong magnetism (from medical equipment, etc.) should be avoided because it can cause malfunction and damage to electronic components.
- Though operation of your watch normally is not affected by magnetism, its accuracy may be affected if the watch itself becomes magnetized. Also, very strong magnetism (from medical equipment, etc.) should be avoided because it can cause malfunction of the watch and damage to electronic components.

Electrostatic Charge

- Exposure to very strong electrostatic charge can cause the watch to display the wrong time. Very strong electrostatic charge even can damage electronic components.
- Electrostatic charge can cause the display to go blank momentarily or cause a rainbow effect on the display.

Chemicals

- Do not allow the watch to come into contact with thinner, gasoline, solvents, oils, or fats, or with any cleaners, adhesives, paints, medicines, or cosmetics that contain such ingredients. Doing so can cause discoloration of or damage to the case, resin band, leather band, and other parts.

Storage

- If you do not plan to use the watch for a long time, wipe it thoroughly free of all dirt, sweat, and moisture, and store it in a cool, dry place.

Resin Components

- Allowing the watch to remain in contact with other items or storing it together with other items for long periods while it is wet can cause the color of the other items to transfer to the resin components of the watch. Be sure to dry off the watch thoroughly before storing it and make sure it is not in contact with other items.
- Leaving the watch where it is exposed to direct sunlight (ultraviolet rays) for long periods or failure to clean dirt from the watch for long periods can cause it to become discolored.
- Friction caused by certain conditions (frequent external force, sustained rubbing, impact, etc.) can cause discoloration of painted components.
- If there are printed figures on the band, strong rubbing of the printed area can cause discoloration.

- Failure to clean dirt from the watch for long periods can cause fluorescent color to fade. Wash dirt off with water as soon as possible and then dry the watch.
- Semi-transparent resin parts can become discolored due to sweat and dirt, and if exposed to high temperatures for long periods.
- Contact an authorized CASIO Service Center to have resin components replaced. Note that you will be charged for replacement costs.

Natural Leather and Imitation Leather Bands

- Allowing the watch to remain in contact with other items or storing it together with other items while it is wet for long periods can cause the color of the other items to transfer to the natural leather or imitation leather band of the watch. Be sure to dry off the watch thoroughly before storing it and make sure it is not in contact with other items.
- Leaving a leather band where it is exposed to direct sunlight (ultraviolet rays) for long periods or failure to clean dirt from a leather band for long periods can cause it to become discolored.

Important!

- Subjecting a natural leather or imitation leather band to rubbing or dirt can cause color transfer and discoloration.

Metal Components

- Failure to clean dirt from a metal band can lead to formation of rust, even if the band is stainless steel or plated. If the watch is exposed to sweat or water, wipe it thoroughly with a soft, absorbent cloth and then store it in a well-ventilated location to dry.
- To clean the band, use a soft toothbrush or similar tool to scrub it with a weak solution of water and a mild neutral detergent. Take care to avoid getting solution on the watch case.

Bacteria and Odor Resistant Band

- The bacteria and odor resistant band protects against odor generated by the formation of bacteria from sweat, which ensures good comfort and hygiene. In order to ensure maximum bacteria and odor resistance, keep the band clean. Use an absorbent soft cloth to wipe the band clean of dirt, sweat, and moisture. The bacteria and odor resistant band suppresses the formation of organisms and bacteria. It does not protect against rash due to allergic reaction, etc.

Display

- Display figures may be difficult to read when viewed from an angle.

Data Protection

- Allowing the battery to go dead, replacing the battery, or having the watch repaired can cause all data in the watch's memory to be lost. Note that CASIO COMPUTER CO., LTD. assumes no responsibility for any damages or losses caused by data lost due to malfunction or repair of the watch, replacement of the battery, etc. Be sure to keep separate written copies of all important data.

Sensors

- The sensors of this watch are precision instruments. Never try to take them apart. Never try to insert any objects into the openings of sensors, and take care to ensure that dirt, dust, or other foreign matter does not get into sensors. After using the watch where it is immersed in saltwater, rinse it thoroughly with fresh water.

User Maintenance

Caring for Your Watch

- A dirty or rusty case or band can soil the sleeve of your clothing, cause skin irritation, and even interfere with watch performance. Be sure to keep the case and band clean at all times. Rust tends to form easily after the watch is exposed to seawater and then left without cleaning.
- Sometimes a smudge like pattern may appear on the surface of a resin band. This will not have any affect on your skin or clothing. Wipe the band with a cloth to clean it.
- Keep a leather band clean by wiping it with a dry cloth. Both resin bands and leather band can become worn and cracked over time when subjected to normal daily use.
- Should your band become badly cracked or worn, be sure to have it replaced with a new one. Request band replacement from your original retailer or an authorized CASIO Service Center. Note that you will be charged for band replacement costs, even if your watch is still covered by its warranty.
- Remember that you wear your watch next to your skin, just like a piece of clothing. Because of this, you should always keep your watch clean. Use a soft, absorbent cloth to wipe off any dirt, sweat, water, or other foreign matter from the case and band.

Dangers of Poor Watch Care

Rust

- Though the stainless steel used for the watch is highly rust-resistant, rust can form if the watch is not cleaned after it becomes dirty. Failure of oxygen to come into contact with the metal because it is dirty causes breakdown of the oxidization layer on the metal surface, which leads to the formation of rust.
- Even if the surface of the metal appears clean, sweat and rust in crevasses can soil the sleeves of clothing, cause skin irritation, and even interfere with watch performance.

Premature Wear

- Leaving sweat or water on a resin band or storing it an area subject to high moisture can lead to premature wear, cuts, and breaks.

Skin Irritation

- Individuals with sensitive skin or in poor physical condition may experience skin irritation when wearing a watch. Such individuals should keep their leather band or resin band particularly clean, or switch to a metal band. Should you ever experience a rash or other skin irritation, immediately remove the watch and contact a skin care professional.

Battery

- The special rechargeable (secondary) battery used by your watch is not intended to be removed or replaced by you. Use of a rechargeable battery other than the special one specified for this watch can damage the watch.
- The rechargeable battery is charged when the solar cell is exposed to light, and so regular periodic replacement is not required. However, charging and discharging of the battery over the years leads naturally to a loss in its ability to sustain a charge and shortens its operating time. If this happens, contact your original retailer or authorized CASIO Service Center.



City Code Table



City Code Table

City Code	City	UTC Offset	Other major cities in same time zone
PPG	Pago Pago	-11.0	
HNL	Honolulu	-10.0	Papeete
ANC	Anchorage	-09.0	Nome
LAX	Los Angeles	-08.0	San Francisco, Las Vegas, Seattle/Tacoma, Dawson City, Tijuana
DEN	Denver	-07.0	El Paso, Edmonton, Culiacan
CHI	Chicago	-06.0	Houston, Dallas/Fort Worth, New Orleans, Winnipeg, Mexico City
NYC	New York	-05.0	Montreal, Detroit, Boston, Panama City, Havana, Lima, Bogota, Miami, Toronto
CCS	Caracas	-04.0	La Paz, Santiago, Port Of Spain
RIO	Rio De Janeiro	-03.0	Sao Paulo, Buenos Aires, Brasilia, Montevideo
FEN	Fernando de Noronha	-02.0	
RAI	Praia	-01.0	
UTC		-	
LON	London	+00.0	Dublin, Casablanca, Dakar, Abidjan
PAR	Paris	+01.0	Milan, Amsterdam, Algiers, Hamburg, Frankfurt, Vienna, Madrid, Rome, Stockholm
BER	Berlin		

City Code	City	UTC Offset	Other major cities in same time zone
ATH	Athens	+02.0	Helsinki, Istanbul, Beirut, Damascus,Cape Town
CAI	Cairo		
JRS	Jerusalem		
JED	Jeddah	+03.0	Kuwait, Riyadh, Aden, Addis Ababa, Nairobi, Moscow
THR	Tehran	+03.5	Shiraz
DXB	Dubai	+04.0	Abu Dhabi, Muscat
KBL	Kabul	+04.5	
KHI	Karachi	+05.0	Male
DEL	Delhi	+05.5	Mumbai, Kolkata, Colombo
DAC	Dhaka	+06.0	
RGN	Yangon	+06.5	
BKK	Bangkok	+07.0	Jakarta, Phnom Penh, Hanoi, Vientiane
HKG	Hong Kong	+08.0	Singapore, Kuala Lumpur, Manila, Perth, Ulaanbaatar, Beijing, Taipei
SEL	Seoul	+09.0	Pyongyang
TYO	Tokyo		
ADL	Adelaide	+09.5	Darwin
SYD	Sydney	+10.0	Melbourne, Rabaul, Guam
NOU	Noumea	+11.0	Port Vila
WLG	Wellington	+12.0	Christchurch, Nadi, Nauru Island

- Based on data as of June 2008.

- UTC offsets and the use of summer time are subject to change in the country where they are used.
- * In December 2007, the UTC offset for Caracas, Venezuela (CCS) was changed from -4.0 to -4.5 . However, this watch still uses the old UTC offset of -4.0 when the Caracas (CCS) city code is selected.