

CITIZEN

User's Manual

CONTROL BOARD FOR MLT-288/MLT-289
MODEL BD2-2880/2890

Rev. 1.00 Newly Issued Aug 9th, 2002

Japan CBM Corporation

CONTENTS

1. OUTLINE	1
1.1 Features	1
1.2 Precaution	1
2. BASIC SPECIFICATIONS	2
2.1 Model Classification	2
2.2 Basic Specifications	3
3. CONNECTING CONNECTORS.....	4
3.1 CN1 Connector for Printer Mechanism (For Print Head)	4
3.2 CN2 Connector for Print Mechanism (For Motor & Sensor)	4
3.3 CN3 Connector for Interface	5
3.4 CN4 Connector for Paper Cutter	6
4. DIP SWITCH SETTING	7
5. POWER SUPPLY	9
5.1 Specifications	9
5.2 Precautions	9
6. PARALLEL INTERFACE	10
6.1 Specifications	10
6.2 Explanation of Input/Output Signals	10
6.3 Electrical Characteristics	10
6.4 Timing Chart	11
6.5 Data Receiving Control	12
6.6 Buffering	12
7. SERIAL INTERFACE	13
7.1 Specifications	13
7.2 Explanation of Input/Output Signals	14
7.3 Error Detection	14
7.4 Data Receiving Control	14
7.5 Buffering	15
7.6 Electrical Characteristics	15

8. ERROR HANDLING	16
8.1 Peripheral Circuit Errors	16
8.2 Operation Errors	16
8.3 Errors Indication	18
9. PRINTER MECHANISM CONTROL SYSTEM	19
9.1 Thermal Head Control System (Division Driving System)	19
9.1.1 Fixed Division Number System	19
9.1.2 Variable Division Number System	19
9.2 Motor Drive	20
9.2.1 Motor Drive Features	20
9.2.2 Maximum Motor Drive Speeds at Major Voltage	20
10. MAINTENANCE AND SERVICE	21
11. PRINT CONTROL FUNCTIONS	22
11.1 Command List	22
11.2 Command Details	25
11.2.1 Description of Items	25
12. CHARACTER CODE TABLE	72
12.1 International	72
12.2 Japanese	73
12.3 International Character Set	74
APPENDIX 1. BLOCK DIAGRAM	75
APPENDIX 2. OUTER DIMENSION	76

1. OUTLINE

This control boards is designed to be used to control our thermal printer, “MLT-288/289” series through the computer etc.

As being provided with many abundant functions, it can be used widely in various applications. Before you start using it, read this manual thoroughly and understand the content.

1.1 Features

- (1) Ultra compact
- (2) Both interface of Serial and Parallel can be selected by dip switch.
- (3) Input buffer incorporated.
- (4) Bar code printing is available (dedicated command).
- (5) Auto paper cutter control incorporated.
- (6) User-defined character registration function (94 characters)
- (7) Low cost

1.2 Precaution

- (1) Make sure to turn OFF the power supply in case of connecting/disconnecting the connectors.
- (2) Absolutely do not make a short circuit between the terminals of connectors.
- (3) Use power supply, LED, interface etc. following their specifications.
- (4) Use the recommended paper shown below.
 - Thermal Paper TF5KS-E2D (Nippon paper)
KF50-HDA (Shin-Oji paper)
F220VP, HP220A (Mitsubishi paper)

2. BASIC SPECIFICATIONS

2.1 Model Classification

Models are identified by the following coding scheme:

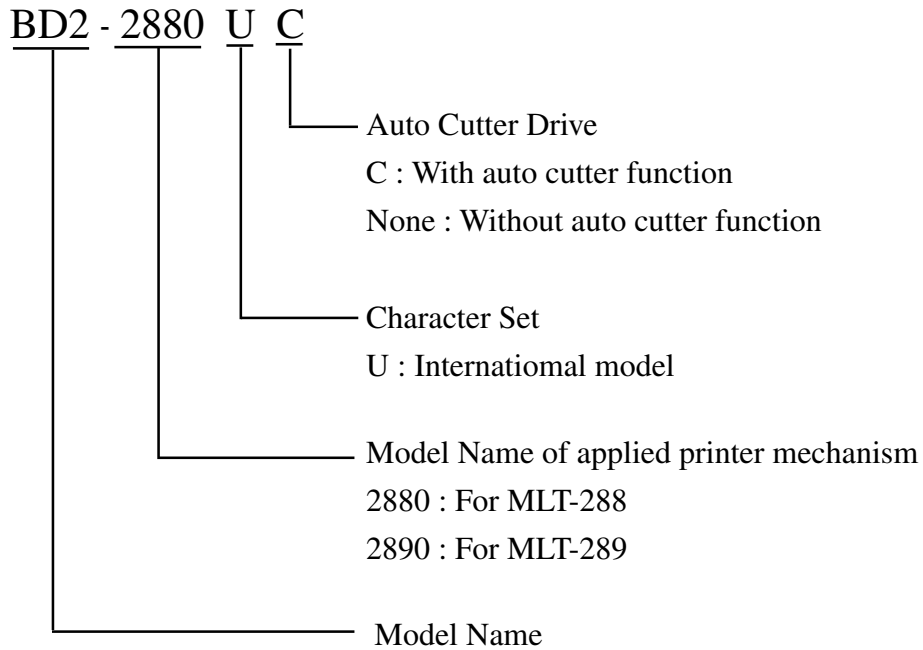

2.2 Basic Specifications

Items	Contents
Printing system	Thermosensitive dot-matrix printing
Print width	48 mm
Print Speed	420 dot line/sec
Number of columns	Font A : 32 columns
	Font B : 42 columns
Character dimensions	Font A : 1.25 mm × 3.00 mm
	Font B : 0.88 mm × 3.00 mm
Character types	Alphanumeric, international characters
Bar code type	UPC-A/E, JAN (EAN) 13/8 columns, ITF CODE 39, CODE128, CODABAR
Line pitch	4.23 mm (Can be changed by command)
Interface	Parallel (Conforms to Centronics) or Serial (Conforms to RS-232C) (Selectable by dip switch)
Input buffer	2 K bytes
Supply voltage	VCC: 5V ± 5 % Approx. 130 mA (Self printing) VP : 4.2V ~ 8.5V Approx. 1.5A (Ave) Approx. 4A (Peak) When 7.2V Ordinal voltage is to be 7.2V (Max) 8.5V is a voltage, which is right after charging.
Weight	Approx. 40 g
Outer Dimension	75 mm (W) × 80 mm (D) (For height of component parts, see outer drawing.)
Operating Environment	5 ~ 40°C , 35 ~ 85% RH (with no dew condensation)
Storage Environment	-20 ~ 60°C , 10 ~ 90% RH (with no dew condensation)

3. CONNECTING CONNECTORS

3.1 CN1 Connector for Printer Mechanism (For Print Head)

Pin No.	Signal Name	I/O	Function
1	VH	–	Power for print head
2	VH	–	Power for print head
3	SI	Output	Head data output signal
4	GND	–	GND
5	TM	Input	Thermistor
6	STRB 1	Output	Strobe 1
7	STRB 2	Output	Strobe 2
8	Vdd	–	Thermal head logics power (+5V)
9	LATCH	Output	Latch signal
10	GND	–	GND
11	STRB 6	Output	Strobe 6
12	CP	Output	Clock pulse
13	GND	–	GND
14	STRB 5	Output	Strobe 5
15	STRB 3	Output	Strobe 3
16	GND	–	GND
17	GND	–	GND
18	STRB 4	Output	Strobe 4
19	GND	–	GND
20	GND	–	GND
21	GND	–	GND
22	VH	–	Power for print head
23	VH	–	Power for print head
24	VH	–	Power for print head

Applicable Connector : 52806-2410 (Molex)

3.2 CN2 Connector for Print Mechanism (For Motor & Sensor)

Pin No.	Signal Name	I/O	Function
1	MOTOR B	Output	Operation signal for motor B
2	MOTOR A	Output	Operation signal for motor A
3	MOTOR B	Output	Operation signal for motor B
4	MOTOR A	Output	Operation signal for motor A
5	PE C	Input	Photo-transistor collector (Paper sensor)
6	GND	–	Photointerruptor emitter + cathode
7	PE A	–	Photo-LED anode (Paper sensor)
8	H-UP	Input	Head-up signal
9	GND	–	Head-up sensor GND

Applicable Connector : 53047-0910 (Molex)

3.3 CN3 Connector for Interface

Pin No.	Signal Name	I/O	Function
1	Vcc	—	Power supply for circuit (5V)
2	Vcc	—	Power supply for circuit (5V)
3	GND	—	GND
4	GND	—	GND
5	Vp	—	Power supply for operation
6	Vp	—	Power supply for operation
7	Vp	—	Power supply for operation
8	Vp	—	Power supply for operation
9	Vp	—	Power supply for operation
10	Vp	—	Power supply for operation
11	P-GND	—	GND for operation
12	P-GND	—	GND for operation
13	P-GND	—	GND for operation
14	P-GND	—	GND for operation
15	P-GND	—	GND for operation
16	P-GND	—	GND for operation
17	LF-SW	Input	LF Switch input
18	ERROR	Output	ERROR LED output (Can be connected directly)
19	PEout	Output	PE LED output (Can be connected directly)
20	DTR	Output	Serial Interface DTR
21	TXD	Output	Serial Interface TXD
22	RXD	Input	Serial Interface RXD
23	DSR	Input	Serial Interface DSR
24	DATA0	Output	Parallel Interface DATA0
25	DATA1	Output	Parallel Interface DATA1
26	DATA2	Output	Parallel Interface DATA2
27	DATA3	Output	Parallel Interface DATA3
28	DATA4	Output	Parallel Interface DATA4
29	DATA5	Output	Parallel Interface DATA5
30	DATA6	Output	Parallel Interface DATA6
31	DATA7	Output	Parallel Interface DATA7
32	STB	Output	Parallel Interface STB
33	BUSY	Output	Parallel Interface BUSY
34	FAULT	Output	Parallel Interface FAULT
35	SELECT	Output	Parallel Interface SELECT
36	PE	Output	Parallel Interface PE
37	NC	Output	Parallel Interface ACK
38	NC	—	No Connection
39	SELECTIN	—	No Connection
40	RESET	Input	Parallel Interface RESET

Applicable Connector : 53313 - 4015 (Molex)

⚠ CAUTION:

1. For LED of $\overline{\text{ERROR}}$ and $\overline{\text{PE}}$, there is a resistor of 330Ω on the circuit side to make current value 10 mA.
Please use LED which its voltage is approx. 2V. LED over 10 mA may break a control board.
2. Control circuit requires power supply only for one pin of each VCC and GND.
However, Operation voltage is to be supplied to all of pin for safety use.
3. Serial interface equips a driver and receiver of RS-232C, make sure to use it at RS-232C level.
4. RESET terminal is pulled up by $3.3K\Omega$. Make sure to make this terminal NC, when this terminal is not used.
5. LF-SW input circuit is as below.

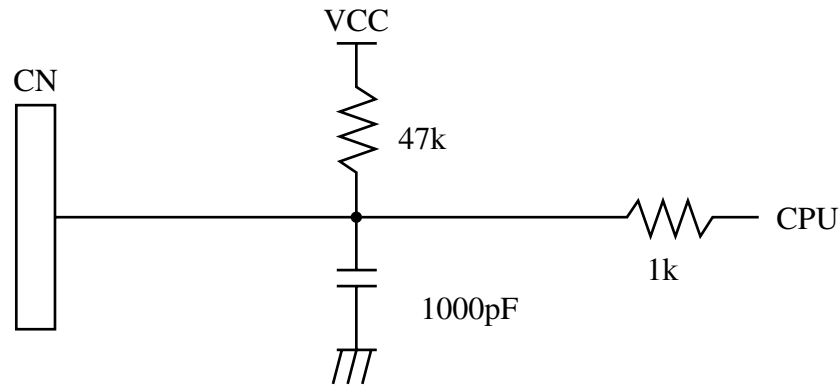

3.4 CN4 Connector for Paper Cutter

Pin No.	Signal Name	I/O	Function
1	M+	Output	Cutter motor operational signal M +
2	M-	Output	Cutter motor operational signal M -
3	GND	—	GND
4	SW	Input	Cutter switch input signal

Using Connector : 5267- 04A-X (Molex)

Note: Use the specified Paper Cutter (Model Name : ACS-220-5V)

4. DIP SWITCH SETTING

(1) DIP SWITCH

Pin No.	Function	ON	OFF	Factory Setting
DS1-1	Auto Cutter	Enable	Disable	OFF
1-2	CR Selection	LF Enable	LF Disable	ON
1-3	Print Density	Combination with J-6 (See next page (5))		OFF
1-4	DTR/XON-XOFF	XON-XOFF	DTR/DSR	OFF
1-5	Baud Rate	See below (3)		OFF
1-6	"			OFF
1-7	"			OFF
1-8	"			OFF

(2) JUMPER

Pin No.	Function	Short	Open	Factory Setting
J1	International Character set	See next page (4)		Short circuit
J2	"			Short circuit
J3	"			Short circuit
J4	Paper Auto Loading	Enable	Disable	Short circuit
J5	Print Drive System	Variable division	Fixed division	Short circuit
J6	Print Density (Supplementary)	Combination with DS1-3 See next page (5)		Short circuit
J7	Not Used	-		Short circuit
J8	Mechanism	MLT-288	MLT-289	Short circuit

*1

*1 : BD2-2890 is set to open circuit.

(3) INTERFACE & BAUD RATE

DS1-8	DS1-7	DS1-6	DS1-5	Input Method	Parity	Baud Rate
OFF	OFF	OFF	OFF	Parallel Input	-	-
OFF	OFF	OFF	ON	Serial Input	None	1200 bps
OFF	OFF	ON	OFF	"	"	2400 bps
OFF	OFF	ON	ON	"	"	4800 bps
OFF	ON	OFF	OFF	"	"	9600 bps
OFF	ON	OFF	ON	"	"	19200 bps
OFF	ON	ON	OFF	"	Odd	1200 bps
OFF	ON	ON	ON	"	"	2400 bps
ON	OFF	OFF	OFF	"	"	4800 bps
ON	OFF	OFF	ON	"	"	9600 bps
ON	OFF	ON	OFF	"	"	19200 bps
ON	OFF	ON	ON	"	Even	1200 bps
ON	ON	OFF	OFF	"	"	2400 bps
ON	ON	OFF	ON	"	"	4800 bps
ON	ON	ON	OFF	"	"	9600 bps
ON	ON	ON	ON	"	"	19200 bps

(4) INTERNATIONAL CHARACTER SET

J-3	J-2	J-1	InternationalCharacter
Open	Open	Open	Japan (JIS)
Open	Open	Short	Japan (Shift-JIS)
Open	Short	Open	Sweden
Open	Short	Short	Denmark 1
Short	Open	Open	U.K.
Short	Open	Short	Germany
Short	Short	Open	France
Short	Short	Short	U.S.A

(5) PRINT DENSITY

DS1-3	J-6	Print Density	Level	Print Density Rate
OFF	Open	Light	0	80%
OFF	Short	Standard	1	100%
ON	Open	Slightly Dark	2	120%
ON	Short	Dark	3	150%

Note:

1. Input Buffer is 2k byte. (Fixed)
 2. Serial data length is 8 bits. (Fixed)
- If print tone is set at 2 or above, printing rate tends to be lowered.

5. POWER SUPPLY

5.1 Specifications

VCC : 5V \pm 5% Approx. 130 mA

VP : 4.2V ~ 8.5V Approx. 1.5A (Peak : Approx. 4A) when 7.2V

Ordinal Voltage is to be 7.2V (Max). 8.5V is a voltage that is right after charging.

8.5V cannot be used for ordinal voltage.

5.2 Precautions

- (1) Design the product to supply power to Vcc before VP when power is supplied to this control board.
- (2) Design the product to turn off the power for Vcc after VP when power is turned off.
- (3) Make sure to turn off the power in case of connecting/disconnecting connectors.
- (4) Make sure to use Vcc and VP following their specifications.
- (5) Make sure to use this control board connecting all of terminals between VP and P-GND.

6. PARALLEL INTERFACE

6.1 Specifications

Data input method : 8 bit parallel signal (DATA0~7)
 Control signals : $\overline{\text{ACK}}$, BUSY, $\overline{\text{STB}}$, $\overline{\text{FAULT}}$, PE, $\overline{\text{RESET}}$

6.2 Explanation of Input/Output Signals

DATA0~7 : 8 bit parallel signal (Positive logic)

$\overline{\text{STB}}$: Strobe signal to read 8 bit data (Negative logic)

$\overline{\text{RESET}}$: Signal to reset control board (Negative logic)

$\overline{\text{ACK}}$: 8 bit data request signal. Pulse signal output at the end of the BUSY signal (Negative logic)

BUSY : Signal to indicate BUSY state of the printer. Input new data for "LOW" (Positive logic)

$\overline{\text{FAULT}}$: Signal which is made "LOW" when printer is in alarm state. (Negative logic)
 In this case all the control logics within the printer stop functioning.

PE : Signal which is output when paper runs out. (Positive logic)

6.3 Electrical Characteristics

(1) Input Signal Level

"HIGH" level : 0.7 Vcc MIN
 "LOW" level : 0.3 Vcc MAX

(2) Output Signal Level

"HIGH" level : Vcc - 0.1V MIN
 "LOW" level : 0.1V MAX

(3) I/O Conditions

$\overline{\text{STB}}$, $\overline{\text{RESET}}$ input signals are pulled up by 3.3K .

Other input signals are pulled up by 50K .

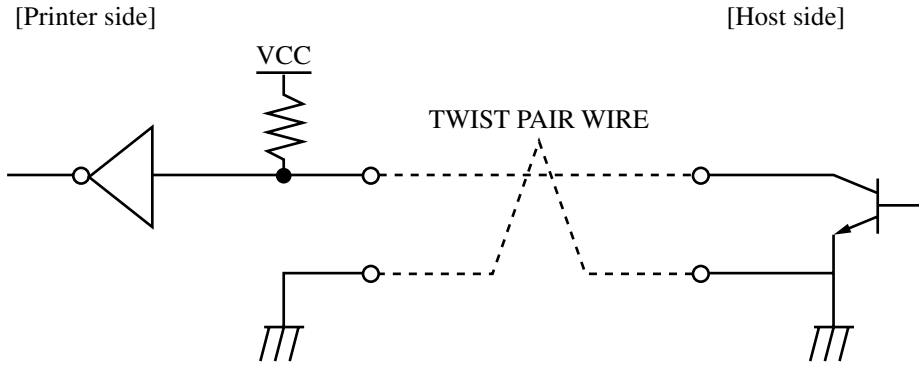

All the output signals are pulled up by 50K

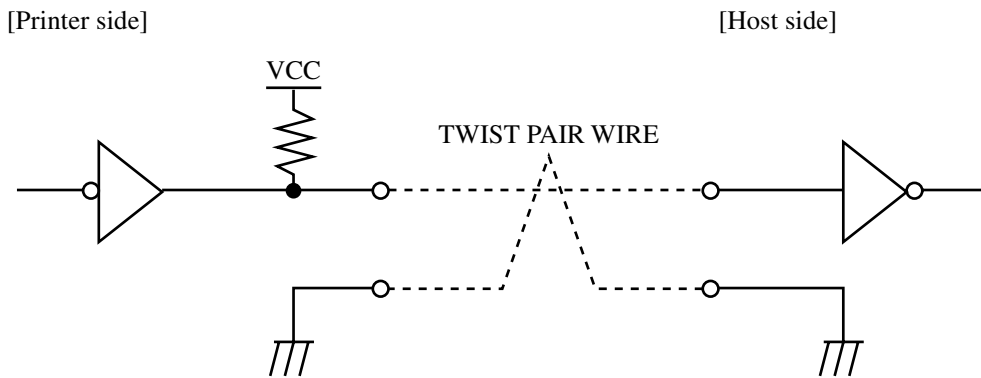

6.4 Timing Chart

(1) Data Input and Printing Timing

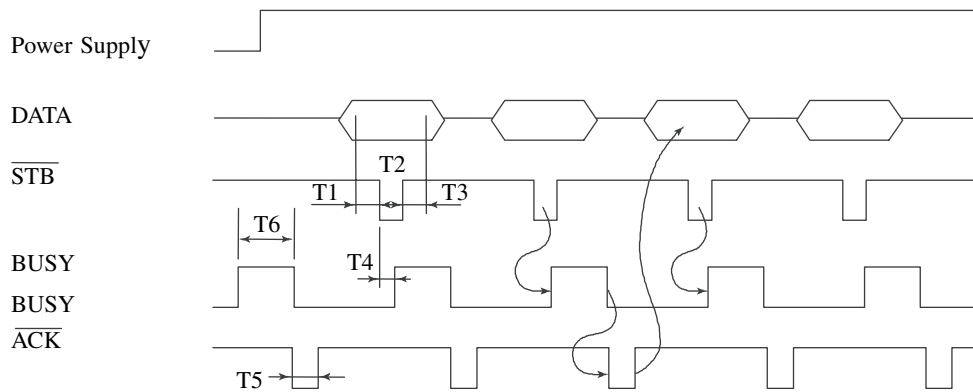

- T1, T2, T3 : 0.5 μ s (MIN)
- T4 : 270 ns (MAX)
- T5 : 2.3 μ s (TYP)
- T6 : 500 ms (MIN) *On supplying power

6.5 Data Receiving Control

When BUSY signal is “LOW”, data from the host can be received. When it being “HIGH”, data cannot be received.

6.6 Buffering

This control board incorporates 2K byte buffer.

Therefore, big data can be buffered in input buffer, and the host side can be released immediately.

7. SERIAL INTERFACE

7.1 Specifications

(1) Data transfer system: Asynchronous

(2) Baud rates

1200, 2400, 4800, 9600, 19200 bps (Selectable by user)

(3) Configuration of one word

Start bit	:	1 bit
Data bit	:	8 bits Fixed
Parity bit	:	Odd/Even or No parity (Selectable by user)
Stop bit	:	1 bit or more

(4) Signal polarity

RS-232C		
• Mark	=	logic "1" (-3V ~ -12V)
• Space	=	logic "0" (+3V ~ +12V)

(5) Receiving data (RD signal)

RS-232C		
• Mark	=	1
• Space	=	0

(6) Receiving control (DTR signal)

RS-232C		
• Mark	:	Data transfer is not available
• Space	:	Data transfer is available

(7) Transmission control (TD signal)

DC1 code (11H) X-ON	:	Data reception is available
DC3 code (13H) X-OFF	:	Data reception is not available

7.2 Explanation of Input/Output Signals

(1) RXD

Serial receiving data signal. On occurrence of framing error, overrun error, or parity error, the data is printed as “?”.

(2) DTR

When this signal is READY, write data or a command. When they are written in BUSY, overrun error is occurred and data is ignored. Data can be written into the input buffer even when the printer is busy printing. A BUSY also occurs when the printer is powered on, in test print, in Online mode, or being reset.

(3) TXD

If data remaining in the printer's input buffer is 256 bytes or less, the printer transfers a DC3 (13H: Data Receive Not Ready) signal to the host. If data in the input buffer exceeds 256 bytes, the printer transfers a DC1 (11H: Data Receive Ready) signal to the host.

(4) GND

Common GND on the circuit.

7.3 Error Detection

Parity, framing, and overrun are detected. On detection of any error, the data are stored in the buffer as “?”.

(1) Framing Error

With “space” state having been detected on detection of a stop bit, error takes place. The data are stored in the buffer as “?”.

(2) Parity Error

With an error having been detected under specifying parity check, the data is stored in the buffer as “?”.

(3) Overrun Error

On detection of an overrun error, the data are stored in the buffer as “?”.

7.4 Data Receiving Control

When DTR/DSR control having been selected, with BUSY signal at “LOW”, data from the host side are received. With the signal at “HIGH”, they can not be received.

When DTR/DSR control not having been selected, after X-ON transmission, data is received from the host side. No transmission of data can take place after X-OFF is transmitted.

8. ERROR HANDLING

8.1 Peripheral Circuit Errors

These errors are detected at power-on or initialization just after a reset.

(1) Error types

Error	Description
Memory error	The CPU made a self-diagnosis of the circuit and detected an error with the external RAM.
Cutter error	With the auto cutter enabled at the function selection terminal (DS1-1), the auto cutter (ACS-220-5V) is not connected to the cutter connector (CN4).

(2) External signal outputs

Pin No	Signal Name	Remarks
20	$\overline{\text{ERROR}}$	LED output. For a blinking pattern, see 8.3 Error Indication.
22	DTR	Serial interface
27	BUSY	Parallel interface
38	$\overline{\text{FAULT}}$	Parallel interface

(3) Resetting methods

Error	Resetting Method
Memory error	Unrecoverable
Cutter error	After turning off the power, connect the auto cutter (ACS-220-5V) or turn off the function selection terminal (DS1-1) and turn on the power again.

8.2 Operation Errors

(1) Error types

Error	Description
No paper	The printing paper set is not set
Head -up	The head-up lever is at its up position
VH voltage error	A VH voltage is beyond its allowable range (4.2 to 8.5V)
Head temperature error	A head temperature is less than 0°C or 65 °C or higher.
Cutter lock (ACS-220-5V)	When driving the cutter, the cutter is locked due to an external factor (Paper jam, etc.).

⚠Caution: The 8.5V upper-limit voltage for VP voltage error is only an assumptive voltage just after charging the battery when using the battery power. It cannot be normally used. A normal maximum voltage is 7.2V.

(2) External signal outputs

Pin No	Signal Name	Remarks
20	$\overline{\text{ERROR}}$	LED output. For a blinking (Lighting) pattern, see 8.3 Error Indication.
21	$\overline{\text{PE OUT}}$	LED output. This is always output at the time of no paper.
22	DTR	Serial interface
27	BUSY	Parallel interface
37	PE	Parallel interface
38	$\overline{\text{FAULT}}$	Parallel interface

(3) Resetting methods



Error	Resetting Method
No paper	Set the paper. See Note 1.
Head -up	Bring down the head-up lever.
VP voltage error	Set to a voltage within the allowable range (4.2 to 8.5V) and turn on the power again. Alternatively, activate the Pin19 (LFSW) of the CN3(interface connector).
Head temperature error	At the lower limit (less than 0 °C), printing becomes operational at 0 °C higher. At the upper limit (65 °C or higher), it become operational at 60 °C or lower.
Cutter lock (ACS-220-5V)	Eliminate paper jam and activate the Pin19(LFSW) of the CN3(Interface Connector) or turn on the power again.

Caution:

1. When auto loading has not been selected with the function selection jumper (J4), set the paper manually. When it has been selected, the auto loading function is enabled to facilitate replacement of the paper.
2. The 8.5V upper-limit voltage for VP voltage error is only an assumptive voltage just after charging the battery when using the battery power. It cannot be normally used. A normal maximum voltage is 7.2V.

8.3 Errors Indication

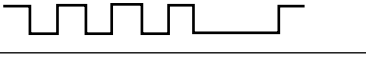
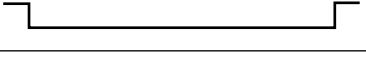
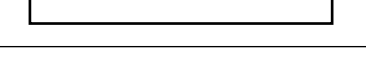
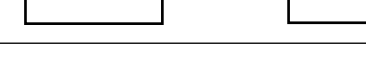
The errors other than no paper are indicated by a LED output (Illumination or blinking) of the Pin 20 (ERROR) of the CN3 (Interface connector).

Error	Display Pattern	Description
Memory error		Blinking cycle of 200ms
Cutter lock (Cutter error)		Blinking cycle of 150ms(3 times) and 500ms(1 time).
Head -up		Illuminated until reverted
VP voltage error		Illuminated until reverted
Head temperature error		Blinking cycle of 1 sec.
Macro execution wait		Blinking cycle of 500ms.

9. PRINTER MECHANISM CONTROL SYSTEM

9.1 Thermal Head Control System (Division Driving System)

The MLT-288 (Line thermal printer) is driven by this control board has a 384 dots/line head divided into 6 blocks of 64 dots each. When actually driving the head, you can select either Fixed Division Number system, which drives the head, always dividing it into 6 blocks or Variable Division Number system which collectively drives several blocks at the time according to the number of activated head dots.

For selection by function selection, see 4. DIP SWITCH SETTING.

For selection by a command, see 11. PRINT CONTROL FUNCTIONS.

9.1.1 Fixed Division Number System

This system always drives each block in the same sequence.

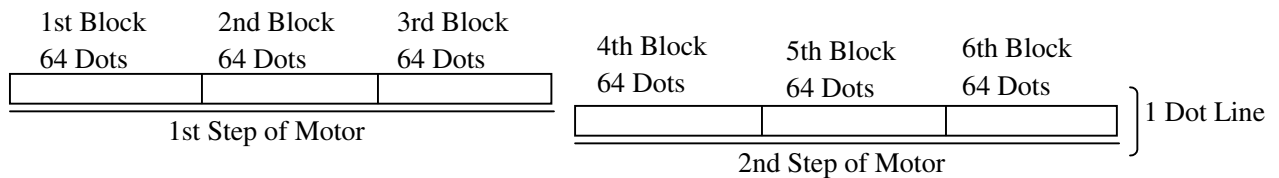

Note: for a stepping motor driving method, see 9.2 Motor Drive.

9.1.2 Variable Division Number System

This system counts the number of printing dots for each block of the printing dot line and drives the blocks collective in such a manner not to exceed the maximum number of driving dots (64 dots).

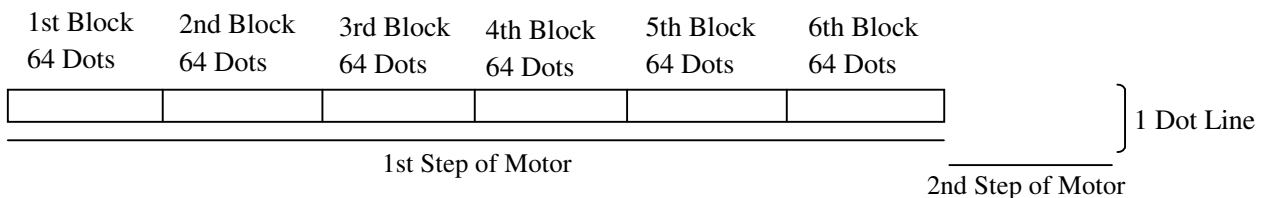

9.2 Motor Drive

The MLT-288 uses a 4-phase bipolar stepping motor. It feeds the 1 dot line worth of paper in two steps by 2-to-2 phase excitation.

9.2.1 Motor Drive Features

- 1) Drive at an optimum drive speed by the VP voltage.
- 2) Prevents heat generation of the motor by PWM control to restrain current consumption.
- 3) Provides acceleration control at the time of start.

9.2.2 Maximum Motor Drive Speeds at Major Voltage

VH Voltage	Motor Drive Speed
5V	400pps
6V	600pps
7.2V	840pps

Caution: The maximum drive speed depends on the VH voltage.

A printing speed may slightly differ depending on a processing time or voltage detection accuracy. During the course of printing, a motor drive speed may be slower than the maximum drive speed, depending on what is printed or the head divided drive system.

10. MAINTENANCE AND SERVICE

For the information on maintenance and service, please contact our dealer or at the following address.

Northern America

CBM America Corporation

Service Center

363 Van Ness Way Suite 404

Torrance, CA 90501, U.S.A

TEL 310-781-1460

FAX 310-781-9157

Other Areas

Japan CBM Corporation

Information Systems Division

5-68-10, Nakano Nakano-ku,

Tokyo 164-0001 Japan

TEL 03-5345-7540

FAX 03-5345-7541

11. PRINT CONTROL FUNCTIONS

11.1 Command List

Print Control Commands

Control Code	Function	Code	Page
LF	Printing and paper feed	0Ah	26
CR	Print command	0Dh	27
ESC J	Printing and feeding paper n/203 inch	1Bh4Ah n	28
ESC d	Printing and feeding the paper by n lines	1Bh64h n	29

Print Character Commands

Control Code	Function	Code	Page
ESC SP	Setting the right space amount of the character	1Bh20h n	30
ESC !	Collective specifying printing mode	1Bh21h n	31
ESC %	Specifying/canceling download character set	1Bh25h n	33
ESC &	Defining download characters	1Bh26h s n m [ap1...psxa]m-n+1	34
ESC -	Specifying/canceling underline	1Bh2Dh n	36
ESC E	Specifying/canceling highlighting	1Bh45h n	37
ESC G	Specifying/canceling double printing	1Bh47h n	38
ESC R	Selecting the international character set	1Bh52h n	39
ESC V	Specifying/Canceling 90°-right- turned Characters	1Bh56h n	40
ESC t	Selecting the character code table	1Bh74h n	41
ESC {	Specifying/canceling the inverted characters	1Bh7Bh n	42

Print Position Commands

Control Code	Function	Code	Page
HT	Horizontal tab command	09h	43
ESC \$	Specifying the absolute positions	1Bh24Ah n1 n2	44
ESC D	Setting horizontal tab position	1Bh44[n]k 00h	45
ESC \	Specifying the relative positions	1Bh 5C n1 n2	46
ESC a	Aligning the characters	1Bh 61h n	47

Line Feed Span Commands

Control Code	Function	Code	Page
ESC 2	Specifying 1/6-inch line feed rate	1Bh 32h	48
ESC 3	Setting line feed rate of minimum pitch	1Bh 33h n	49

Bit Image Commands

Control Code	Function	Code	Page
ESC *	Specifying the bit image mode	1Bh 2Ah m n1 n2[d]k	50
GS *	Defining the download, bit image	1Dh 2Ah n1 n2	52
GS /	Printing the download, bit image	1Dh 2F	54

Status Command

Control Code	Function	Code	Page
ESC v	Transmitting the printer status (Serial type)	1Bh 76h	55

Panel Switch Command

Control Code	Function	Code	Page
ESC c5	Enabling/disabling the panel switches	1Bh 63h 35h n	56

Macro Commands

Control Code	Function	Code	Page
GS :	Starting/ending macro definition	1Bh 63h 35h n	59
GS ^	Executing the macro	1Dh 5Eh n1 n2 n3	58

Cutter Commands

Control Code	Function	Code	Page
ESC i	Activating auto cutter (Full cut)	1Bh 69h	59
ESC m	Activating auto cutter (Partial cut)	1Bh 6Dh	60

Bar Code Commands

Control Code	Function	Code	Page
GS H	Selecting of print position of HRI code	1Dh 48H n	61
GS f	Selecting the font of HRI code	1Dh 66H n	62
GS h	Selecting the height of the bar code	1Dh 68H n	63
GS k	Printing the bar code	1Dh 6Bh n['d']k 00h	64
GS w	Selecting the horizontal size (scale factor) of bar code	1Dh 77H n	68

Other Commands

Control Code	Function	Code	Page
ESC =	Data input control	1Bh 3Dh n	69
ESC @	Initializing the Printer	1Bh 40h	70
DC2 A	Selecting the Print drive system	12h 41h n	71

NOP Commands

Control Code	Function	Code	Page
ESC c 3	NOP	–	–
ESC c 4	NOP	–	–
ESC p	NOP	–	–
ESC u	NOP	–	–

11.2 Command Details

11.2.1 Description of Items

XXXX

ALL

[Function]	Command Function
[Code]	A sequence of code constituting a command is represented in hexadecimal number for < >H, binary number for < >B, and decimal number for < >, respectively; []k represents a repeat count of k-times.
[Range]	Describes an argument value(setting range) for the command.
[Outline]	Describes a command outline.
[Caution]	Describes a caution as required.
[Default]	Describes an initial value for the command when accompanied by an argument.
[See Also]	Describes the associated commands for use.
[Sample Program]	Describes a coding example in the Q-BASIC sample program. * This example is only for your reference and differs depending on the language used, version, and so on. For details, see the manual for the language used.

LF

[Function] Printing and Paper Feed Command

[Code] <0A>H

[Outline] Prints data inside the input buffer and feeds lines based on the line feed amount having been set.

- The head of the line becomes the next print starting position.

[See Also] ESC 2, ESC 3

[Sample Program]

```
LPRINT "AAA" + CHR$ (&HA);  
LPRINT "BBB" + CHR$ (&HA);  
LPRINT CHR$ (&HA);  
LPRINT "CCC" + CHR$ (&HA);
```

[Print Results]

AAA	←	Print and line feed
BBB	←	Print and line feed
	←	Line feed only
CCC	←	Print and line feed

CR

[Function] Print Command

[Code] <0D>H

[Outline] 1) When DS 1-2 is OFF:
This command is ignored.

2) When DS 1- 2 is ON:
With data held inside the internal print buffer, printing and line feed are performed.
Without data inside the internal print buffer, however, no printing is performed.

[See Also] LF

[Sample Program]

```
LPRINT "AAA" + CHR$ (&HD);  
LPRINT "BBB" + CHR$ (&HD);  
LPRINT CHR$ (&HD);  
LPRINT "CCC" + CHR$(&HD);
```

[Print Results]

AAA	← Print and line feed
BBB	← Print and line feed
	← Line feed only
CCC	← Print and line feed

ESC J n

[Function] Printing and feeding paper n/203 inch

[Code] <1B>H<4A>H<n>

[Range] {0 =< n =< FF} Data is described in Hex code.

[Outline] Prints data inside the print buffer and feeds paper by n/360 inch. Since an actual mechanical pitch is 1/203 inch, it is internally converted approximate to the value specified with this command.

- Specified volume does not remain.
- The beginning of the line is to be considered as the next printing start position.
- Initial value is not defined.

[Sample Program]

[Print Results]

See Sample Program and Print Results for ESC 2 on Page 48.

ESC d n

[Function] Printing and Feeding the paper by n lines

[Code] <1B>H<64>H<n>

[Range] * {0 =< n =< FF} Data is described in Hex code.

[Outline] Prints data inside the buffer and feeds paper by n lines.

- Specified line does not remain.
- The beginning of the line is to be considered as the next printing start position.

[Default] • The initial value is not defined.

[Sample Program]

```
LPRINT "AAAAA"
LPRINT CHR$ (&H1B) + "d" + CHR$ (2);
LPRINT "AAAAA" + CHR$ (&HA);
```

[Print Results]

```

A A A A A
      |
      | 2/6-inch line feed
      |
A A A A A
```

ESC SP n

[Function] Setting the right space amount of the character

[Code] <1B>H<20>H<n>

[Range] {0 =< n=< 20} Data is described in Hex code.

[Outline] The rightward space amount is set in dot unit (1/203 inch unit). In the initial value, it is n=0.

[Caution] The rightward space amount in doublewide mode is made double of the set volume.

[Default] n = 0

[Sample Program]

```
LPRINT CHR$ (&H1B) + " " + CHR$ (0);
LPRINT "AAAAA" + CHR$ (&HA);
LPRINT CHR$ (&H1B) + " " + CHR$ (1);
LPRINT "AAAAA" + CHR$ (&HA);
LPRINT CHR$ (&H1B) + " " + CHR$ (12);
LPRINT "AAAAA" + CHR$ (&HA);
```

[Print Results]

```
A A A A A ← 0-dot space
A A A A A ← 1-dot space
A A A A A ← 12-dot space
```

ESC ! n

[Function] Collective Specifying Printing Mode

[Code] <1B>H<21>H<n>

[Range] {0 =< n=< FF} Data is described in Hex code.

[Outline] Printing mode is assigned. Each n bit indicates the following:

Bit	Function	Value	
		0	1
0	Character Font	Font A	Font B
1	Undefined		
2	Undefined		
3	High-lighting	Canceled	Specified
4	Double height	Canceled	Specified
5	Double width	Canceled	Specified
6	Undefined		
7	Underline	Canceled	Specified

- [Caution]**
- With double height and double width being specified simultaneously, double wide and double high characters are consisted.
 - An underline is attached to the full character width, which, however, is not attached to the part having been skipped by the horizontal tab.
Neither is it attached to 90°-right-turned characters.
 - The underline width is as having been specified by <ESC ->.
(The default setting is 1 dot width.)
 - Specification with this command is invalid to Kanji, except specification and cancellation of highlighting
 - In case that double wide character and normal character exist in same one line, the layout of underline is consistent one.

[Default] n = 0

[See Also] ESC E,ESC –

[Sample Program]

```
LPRINT CHR$ (&H1B) + " !" + CHR$ (&H00) + "H" ;
LPRINT CHR$ (&H1B) + " !" + CHR$ (&H01) + "H";
LPRINT CHR$ (&H1B) + " !" + CHR$ (&H08) + "H";
LPRINT CHR$ (&H1B) + " !" + CHR$ (&H10) + "H";
LPRINT CHR$ (&H1B) + " !" + CHR$ (&H20) + "H";
LPRINT CHR$ (&H1B) + " !" + CHR$ (&H80) + "H";
LPRINT CHR$ (&H1B) + " !" + CHR$ (&HB9) + "H";
LPRINT CHR$ (&HA);
```

[Print Results]

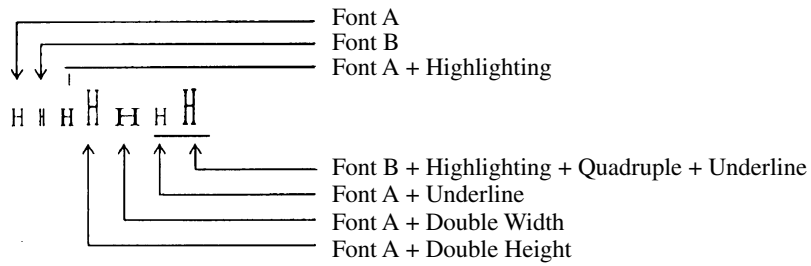

ESC % n

[Function] Specifying/Canceling Download Character Set

[Code] <1B>H<25>H<n>

[Range] {0 =< n =< FF} data is described in Hex code.

[Outline] Specifying/canceling download characters.
Further, only the lowest bit (n0) is valid for n.

The lowest bit (n0) indicates the following.

n0	Function
0	Canceling download character set
1	Specifying download character set

[Caution] Download characters and download bit images cannot be defined simultaneously.

[Default] n = 0

[See Also] ESC &

[Sample Program]

```

GOSUB SETCHR                DATA 6
LPRINT CHR$ (&H1B) + "%" + CHR$ (0); DATA &HFF, &H80, &H00
LPRINT "@A" + CHR$ (&HA);    DATA &H80, &H80, &H00
LPRINT CHR$ (&H1B) + "%" + CHR$ (1); DATA &H80, &H80, &H00
LPRINT "@A" + CHR$ (&HA);    DATA &H80, &H80, &H00
END                          DATA &HFF, &HFF, &HFF
SETCHR:                      DATA &HFF, &HFF, &HFF
LPRINT CHR$ (&H1B) + "&";    DATA 12
LPRINT CHR$ (3) + "@" + "A"; DATA &HFF, &HFF, &HFF
FOR J=1 TO 2                 DATA &H80, &H07, &HF9
READ REP                    DATA &H80, &HFF, &HF9
LPRINT CHR$ (REP);          DATA &H87, &HFE, &H01
FOR I=1 TO REP*3            DATA &H9F, &H06, &H01
READ D                      DATA &HF8, &H06, &H01
LPRINTCHR$ (D);            DATA &HF8, &H06, &H01
NEXT I                      DATA &H9F, &H06, &H01
NEXT J                      DATA &H87, &HFE, &H01
RETURN                      DATA &H80, &HFF, &HF9
                            DATA &H80, &H07, &HF9
                            DATA &HFF, &HFF, &HFF

```

[Print Results]

@ A ← Internal Character Set
 ← Download Character

ESC & s n m [a [p] s × a] m – n +1

[Function] Defining Download Character

[Code] <1B>H<26>H<s><n><m> [<a><p1><p2><ps×a>]m-n+1

[Range] {s = 03}
 {20 (Hex) =< n =< m =< 7E (Hex)}
 {0 =< a =< 0C(Hex)} (Font A)
 {0 =< a =< 0A(Hex)} (Font B)

[Outline] Defines the font of download characters of alphanumeric characters.

- "s" indicates the number of bytes in vertical direction.
- "n" indicates the start character code and m the end character code. To define only one character, set n=m.
- Character codes definable includes 95 ASCII codes in total between <20>H~<7E>H.
- "a" indicates the number of dots in horizontal direction for definition.
- "p" is the data to be defined, which indicate a pattern equal to "a" dot in horizontal direction from the left end. The rest of the pattern on the right side is filled with space.
 The rest of data to be defined is s x a.
- Download characters thus defined remain valid until redefinition, ESC @ execution, GS * execution, or power OFF is practiced.

[Caution] Download characters and download bit images can not be defined simultaneously.
 Running this command clears the definition of the download bit image.

[Default] Same as the internal character set

[Example]

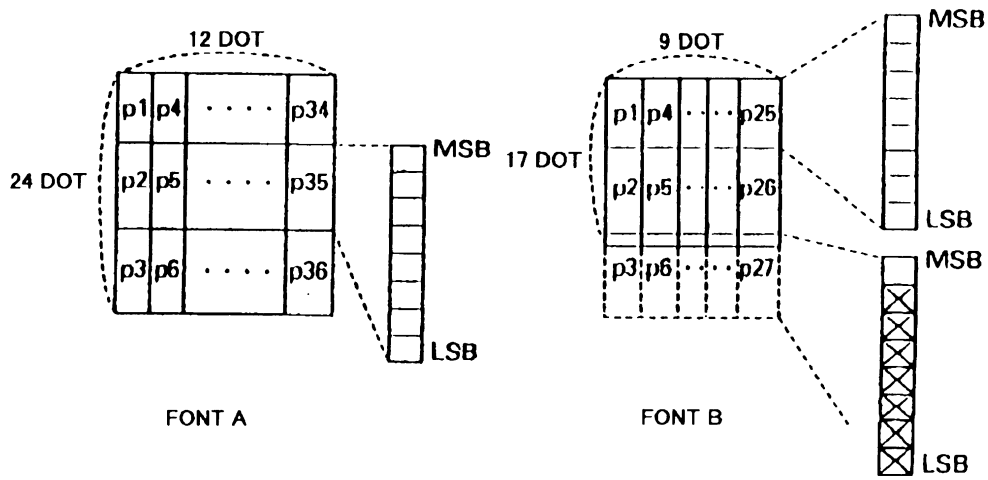

Create each data bit by setting "1" for a printed dot and "0" for an unprinted dot.

[Sample Program]

[PrintResults]

See Sample Program and Print Results for ESC % on Page 33.

ESC - n**[Function]** Specifying/ Canceling Underline**[Code]** <1B>H<2D>H<n>**[Range]** {0 =< n =< 02} data is described in Hex code.**[Outline]** Specifying/canceling an underline.

- Types of underlines by n value are shown below:

n (Hex)	Type
0	Canceling an underline.
1	Specifying an underline for 1-dot width.
2	Specifying an underline for 2-dots width.

- [Caution]**
- An underline is attached to the full character width. It is, however, not attached to the part having been skipped by horizontal tab command.
 - An underline is not attached to a 90 °- right-turned characters.
 - Specification/cancellation with this command is invalid to Kanji.

[See Also] ESC !, FS –**[Sample Program]**

```
LPRINT CHR$ (&H1B) + "-" + CHR$ (0);
LPRINT "AAAAA" ;
LPRINT CHR$ (&H1B) + "-" + CHR$ (1);
LPRINT "AAAAA" + CHR$ (&HA);
```

[Print Results]

Underline Canceled
 ← A A A A A → A A A A A
 ←—————→
 Underline Specified

ESC E n

[Function] Specifying/canceling highlighting

[Code] <1B>H<45>H<n>

[Range] {0 =< n =<FF} Data is described in Hex code.

[Outline] Specifying/canceling the highlighting characters.

- "n" is valid only for the lowest bit (n0).
- Control by the lowest bit (n0) is shown as follows:

n0	Type
0	Canceling highlighting.
1	Specifying highlighting.

- This is effective to all characters.
- Dot configuration of a highlighted character includes one extra dot added at its side.

[Caution] • The print result of Double printing and highlight character printing is completely same.

[See Also] ESC !

[Example]

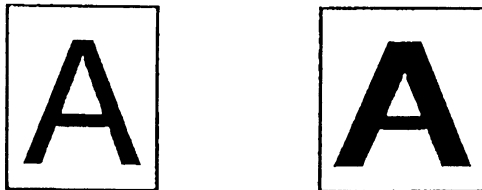

[Sample Program]

```
LPRINT CHR$ (&H1B) + "E" + CHR$ (0);
LPRINT "AAABBB" + CHR$ (&HA);
LPRINT CHR$ (&H1B) + "E" + CHR$ (1);
LPRINT "AAABBB" + CHR$ (&HA);
```

[Print Results]

```
A A A B B B ← Highlighting canceled
A A A B B B ← Highlighting canceled
```

ESC G n

[Function] Specifying/canceling Double Printing

[Code] <1B>H<47>H<n>

[Range] {0 =< n =< FF} Data is described in Hex code.

[Outline] Specifying/canceling the double printing.

- "n" is valid only for the lowest bit (n0).
- Control by n is shown as follows.

n0	Type
0	Canceling double printing.
1	Specifying double printing.

- This is effective to all characters.

[Caution] • The print result of Double printing and highlight character printing is completely same.

[See Also] ESC E

[Sample Program]

```
LPRINT CHR$ (&H1B) + "G" + CHR$ (0);
LPRINT "AAABBB" + CHR$ (&HA);
LPRINT CHR$ (&H1B) + "G" + CHR$ (1);
LPRINT "AAABBB" + CHR$ (&HA);
```

[Print Results]

A A A B B B ← Highlighting canceled

A A A B B B ← Highlighting canceled

ESC R n

[Function] Selecting the International Character set

[Code] <1B>H<52>H<n>

[Range] {0 =< n =< 0A) Data is described in Hex code.

[Outline] Depending on the value of n, following character sets are specified.

n(Hex)	Character Set
0	U.S.A.
1	France
2	Germany
3	U.K.
4	DenmarkI
5	Sweden
6	Italy
7	Spain
8	Japan
9	Norway
A	DenmarkII

[Default] • The initial value of n indicates the character set specified by Jumper (J1~J3).

[See Also] Character Code Table (International Character Set)

[Sample Program]

```
FOR I=0 TO 10
LPRINT CHR$ (&H1B) + "R" + CHR$ (I);
LPRINT " #${¥}^";
LPRINT CHR$ (&H60) + "{¥} ~";
LPRINT "n=" + STR$ (I);
LPRINT CHR$ (&HA);
NEXT I
```

[Print Results]

```
#$@[\\]^`{|}~ n = 0
#$à°çš`éùè" n = 1
#$ŠǺŮŮ^`äöüß n = 2
£$@[\\]^`{|}~ n = 3
#$@ÆØÅ^`æøǺ~ n = 4
#ǺÉǺŮǺÜéäöǺü n = 5
#$@°\é^ùäöèï n = 6
R$@;N¿^`~n}~ n = 7
#$@[¥]^`{|}~ n = 8
#ǺÉÆØÅÜéæøǺü n = 9
#$ÉÆØÅÜéæøǺü n = 10
```

ESC V n

[Function] Specifying/Canceling 90°-right- turned Characters

[Code] <1B>H<56>H<n>

[Range] {0 =< n =< 1} Data is described in Hex code.

[Outline] Specifying/canceling characters 90°-right- turned character.

- "n" means the followings.

n (Hex)	Condition
0	Canceling 90°-right- turned Characters
1	Specifying 90°-right- turned Characters

[Caution] • No underlines are attached to 90°-right- turned characters.

[Default] • The initial value of n is "0".

[Sample Program]

```
LPRINT CHR$ (&H1B) + "V" + CHR$ (0);
LPRINT "AAAAA";
LPRINT CHR$ (&H1B) + "V" + CHR$ (1);
LPRINT "AAAAA" + CHR$ (&HA);
```

[Print Results]

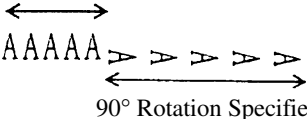
90° Rotation Canceled

 90° Rotation Specified

ESC t n

[Function] Selecting Character Code Table

[Code] <1B>H<74>H<n>

[Range] {0 =< n =< 1} Data is described in Hex code.

Selecting Page n on the character code table:

The character code table is selected depending on the value of n.

"n" means the followings.

n (Hex)	Condition
0	Page0(IBM Character #2)
1	Page1(Domestic Character)

[Default] The initial value of n is subject to the character set for the country specified by the Jumper(J1~J3).

- When Japan is selected: Domestic characters
- When non-Japan is selected: IBM characters #2

[See Also] Character Code Table

[Sample Program]

```
LPRINT CHR$ (&H1B) + "t" + CHR$ (0);
LPRINT " n=0    ";
FOR C=&HB1 TO &HB5
LPRINT CHR$ (C);
NEXT C
LPRINT CHR$ (&HA);
LPRINT CHR$ (&H1B) + "t" + CHR$ (1);
LPRINT " n=1    ";
FOR C=&HB1 TO &HB5
LPRINT CHR$ (C);
NEXT C
LPRINT CHR$ (&HA);
```

[Print Results]

```
n = 0    𠄎 | | | ← Page 0
n = 1    アイエ ← Page 1
```

ESC { n

[Function] Specifying/Canceling the Inverted Characters

[Code] <1B>H<7B>H<n>

[Range] {0 =< n =< FF} Data is described in Hex code.

[Outline] Specifying/canceling inverted characters.

- "n" is valid only for the lowest bit (n0).
- Bit n (n0) means the followings.

n0	Condition
0	Canceling inv rted characters.
1	Specifying inverted characters.

[Caution]

- Inverted-printing means printing the line at 180°turned.
- This is valid only when this is specified at the beginning of a line.

[Default] • The initial value of n is "0".

[Sample Program]

```
LPRINT CHR$ (&H1B) + "{" + CHR$ (0);
LPRINT "AAAAA" + CHR$ (&HA);
LPRINT "BBBBB" + CHR$ (&HA);
LPRINT CHR$ (&H1B) + "{" + CHR$ (1);
LPRINT "AAAAA" + CHR$ (&HA);
LPRINT "BBBBB" + CHR$ (&HA);
```

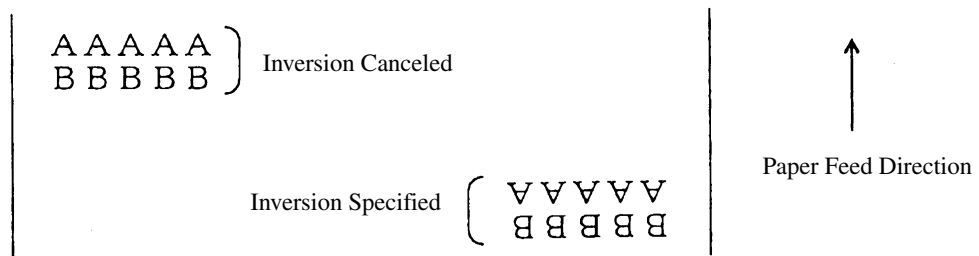
[Print Results]

HT

[Function] Horizontal Tab Command

[Code] <09>H

[Outline] Shifts the printing position to the next horizontal tab position.

- Ignored when the next horizontal tab position has not been set.

[Caution]

- The horizontal tab position is set by ESC D.
- Initial setting of the horizontal tab position is each 8 characters in 9th, 17th, 25th, columns.

[See Also] ESC D

[Sample Program]

```
LPRINT "0123456789012345678901";
LPRINT CHR$ (&HA);
LPRINT CHR$ (&H9) + "AAA";
LPRINT CHR$ (&H9) + "BBB";
LPRINT CHR$ (&HA);
LPRINT CHR$ (&H1B) + "D";
LPRINT CHR$ (3) + CHR$ (7) + CHR$ (14) + CHR$ (0);
LPRINT CHR$ (&H9) + "AAA";
LPRINT CHR$ (&H9) + "BBB";
LPRINT CHR$ (&H9) + "CCC" + CHR$ (&HA);
```

[Print Results]

```
012345678901234567890 1
      AAA      BBB ← Initially set horizontal tab
    AAA BBB    CCC ← When set to the 4th, 8th, and 15th digits
```

ESC \$ n1 n2

[Function] Specifying the Absolute Positions

[Code] <1B>H<24>H<n1><n2>

[Range] {0 =< n1 =< FF}
{0 =< n2 =< 1} Data is described in Hex code.

[Outline] The printing start position is specified in the number of dots (1/203 inch unit) from the beginning of line.

- The number of dots is divided by 256, whose quotient is taken as n2 and the residual as n1.
- Therefore, the printing start position is equal to n1+n2 x 256 from the beginning of line.

[Caution] • Specifying beyond the line end is ignored.

[Default] • The initial value is not specified.

[See Also] ESC \

[Sample Program]

```
LPRINT CHR$ (&H1B) + "$";
LPRINT CHR$ (0) + CHR$ (0) + "A";
LPRINT CHR$ (&H1B) + "$";
LPRINT CHR$ (50) + CHR$ (0) + "B";
LPRINT CHR$ (&H1B) + "$";
LPRINT CHR$ (0) + CHR$ (1) + "C";
LPRINT CHR$ (&HA);
LPRINT CHR$ (&H1B) + "$";
LPRINT CHR$ (100) + CHR$ (0) + "A";
LPRINT CHR$ (&H1B) + "$";
LPRINT CHR$ (&HC2) + CHR$ (&HFF) + "B";
LPRINT CHR$ (&HA);
```

[Print Results]

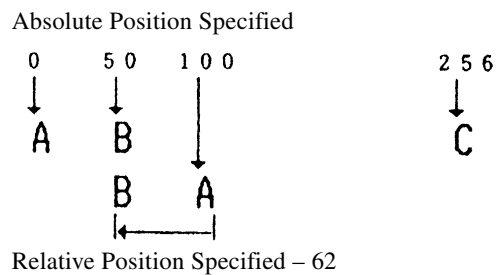

ESC D [n] k NUL

[Function] Setting Horizontal Tab Position

[Code] <1B>H<44>H [<n>] k<00>H

[Range] {0 =< n =< FFH} Data is described in Hex code.
 {0 =< k =< 20H} Data is described in Hex code.

[Outline] Specifying a horizontal tab position.

- "n" indicates the no. of columns from the beginning to the horizontal tab position.
 At this time, n= set position – 1 is to be specified. For example, to set the position at 9th column, n=8 is to be specified.
- k denotes the number of horizontal tab positions you want to set.
- The tab position is set at position where it is "character width x n" from the line beginning.
 The character width, at this time, includes the rightward space amount.
 In double wide characters, it is made double of the ordinary case.
- Tab positions can be specified are maximum 32. Specifying exceeding this is ignored.
- <n> k, which denotes a setting position, is input in the increasing order and ends at <00> H.
- ESC D NUL clears all the set tab positions. Following clearing, horizontal tab command is ignored.

[Caution] When the data, <n> k, is equal to or smaller than its preceding data, <n> k-1, it is assumed that tab setting is finished. If this is the case, the next data onward will be processed as normal data.

When the data, <n> k, exceeds a 1-line print area, set the horizontal tab position, assuming "Set digit position = Maximum print digits + 1." The horizontal tab position does not change even if the character width is altered after setting the horizontal tab position.

[Default] • Initial value is specified for each eight characters(9th.17th.25th column) of ANK characters.

[See Also] HT

[Sample Program]

[Print Results]

See Sample Program and Print Results for HT on Page 43.

ESC \ n1 n2

[Function] Specifying the Relative Positions

[Code] <1B>H<5C>H<n1><n2>

[Range] {0 =< n1 =< FF}
{0 =< n2 =< FF} Data is described in Hex code.

[Outline] The printing start position is specified in the number of dots(1/203 inch unit) from the current position.

- Rightward direction is taken as plus and leftward direction as minus.
- To specify N dot in minus (left) direction, use a complement of N for assignment.
-N dots = 65536 - N
- The number of dots is divided by 256, whose quotient is taken as n2 and the residual as n1.

[Caution] • Specifying exceeding the top of line or the end of line is ignored.

[Default] • The initial value is not specified.

[See Also] ESC \$

[Sample Program] **[Print Results]**

See Sample Program and Print Results for ESC \$ on Page 44.

ESC a n

[Function] Aligning the characters

[Code] <1B>H<61>H<n>

[Range] {0 =< n =< 2} Data is described in Hex code.

[Outline] All the printed data within one line are aligned in the specified position.

- Depending on n value, positional alignment is carried out as in the table below:

n (Hex)	Position
0	Left end alignment
1	Centering
2	Right end alignment

- [Caution]**
- This is valid only when n is inputted at the beginning of line.
 - The initial value of n is "0".

[Sample Program]

```
LPRINT CHR$ (&H1B) + "a" + CHR$ (0);
LPRINT "AAAAA" + CHR$ (&HA);
LPRINT CHR$ (&H1B) + "a" + CHR$ (1);
LPRINT "AAAAA" + CHR$ (&HA);
LPRINT CHR$ (&H1B) + "a" + CHR$ (2);
LPRINT "AAAAA" + CHR$ (&HA);
```

[Print Results]



ESC 2

[Function] Specifying 1/6-inch line feed rate

[Code] <1B>H<32>H

[Outline] The line feed rate per line is specified by 1/6 inch.

[Sample Program]

```
LPRINT "AAAAA" + CHR$ (&HA);
LPRINT CHR$ (&H1B) + "3" + CHR$ (0);
LPRINT "AAAAA" + CHR$ (&HA);
LPRINT CHR$ (&H1B) + "3" + CHR$ (50);
LPRINT "AAAAA" + CHR$ (&HA);
LPRINT CHR$ (&H1B) + "2";
LPRINT "AAAAA" + CHR$ (&HA);
LPRINT "AAAAA";
LPRINT CHR$ (&H1B) + "J" + CHR$ (100);
LPRINT "AAAAA" + CHR$ (&HA);
LPRINT "AAAAA" + CHR$ (&HA);
```

[Print Results]

```
A A A A A 1/6-inch line feed
A A A A A *
A A A A A 0/360-inch line feed
A A A A A *
50/360-inch line feed
A A A A A *
A A A A A 1/6-inch line feed
A A A A A *
100/360-inch line feed
A A A A A *
A A A A A 1/6-inch line feed
A A A A A
```

ESC 3 n

[Function] Setting line feed rate of minimum pitch

[Code] <1B>H<33>H<n>

[Range] {0 =< n =< FF} Data is described in Hex code.

[Outline] The line feed rate per line is specified by n/360 inch.
Since an actual mechanical pitch is 1/203 inch, it is internally converted approximate
to the value specified with this command.

[Default] • The initial value is n = 60 (1/6 inch) (18H), being 4.23 mm line feed rate.

[Sample Program]

[Print Results]

See Sample Program and Print Results for ESC 2 on Page 48.

ESC * m n1 n2 [d] k

- [Function]** Specifying the Bit Image Mode
- [Code]** <1B>H<2A>H<m><n1><n2> [<d>] k
- [Range]** {m= 0, 1, 32, 33 bit image mode (See the table below.)}
- {0 =< n1 =< FF(Hex)}
- {0 =< n2 =< 03(Hex)}
- {0 =< d =< FF(Hex)}
- {k = n1 + FF(Hex) × n2 (m = 0, 1)}
- {k = (n1+ FF(Hex)×n2)×3 (m = 32, 33)}

- [Outline]** According to the number of dots specified in n1, n2, specify the bit image of mode n.
- The No. of dots printed is divided by 256, whose quotient is taken as n2 and residual as n1.
 - The total no. of dots printed in the bit image is equal to n1 + (256 x n2).
 - When bit image data have been input in excess of dot position of one line (448 dots) , the excess data are discarded.
 - d is bit image data, the bits subject to printing are taken as "1" and those not as "0".
 - The bit image modes specified by m are shown as follows:

m(Hex)	Mode	Vertical Direction		Horizontal Direction	
		No. of Dots	Dot Density	Dot Density	Max. No. of Dots
0	8-dot single density	8	67 DPI	101 DPI	192
1	8-dot double density	8	67 DPI	203 DPI	384
32	24-dot single density	24	203 DPI	101 DPI	192
33	24-dot double density	24	203 DPI	203 DPI	384

- [Caution]**
- When the values set in m (bit image mode) are out of the above range, the data following after n1 is processed as normal printing data.
 - After completion of bit image printing, printer returns to normal data processing mode.

[Example]

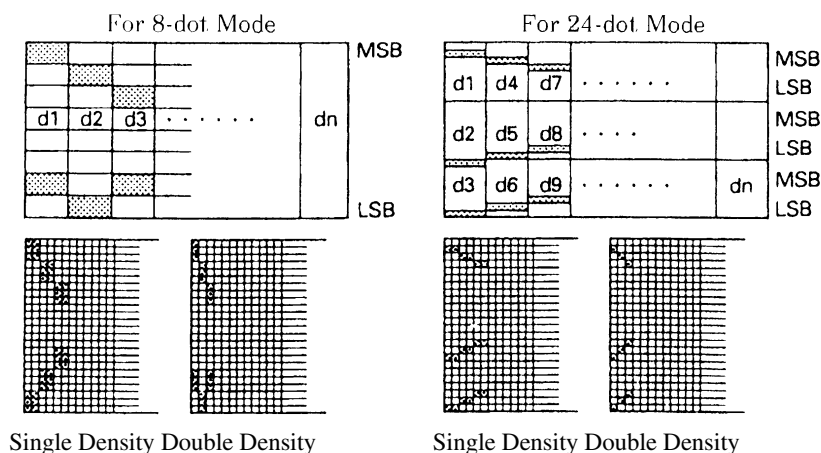

[Sample Program]

```

LPRINT CHR$ (&H1B) + "***";
LPRINT CHR$ (0) + CHR$ (20) + CHR$ (0);
GOSUB IMG1
LPRINT CHR$ (&HA);
LPRINT CHR$ (&H1B) + "***";
LPRINT CHR$ (1) + CHR$ (20) + CHR$ (0);
GOSUB IMG1
LPRINT CHR$ (&HA);
LPRINT CHR$ (&H1B) + "***";
LPRINT CHR$ (32) + CHR$ (20) + CHR$ (0);
GOSUB IMG2
LPRINT CHR$ (&HA);
LPRINT CHR$ (&H1B) + "***";
LPRINT CHR$ (33) + CHR$ (20) + CHR$ (0);
GOSUB IMG2
LPRINT CHR$ (&HA);
END

```

```

IMG1 :
LPRINT CHR$ (&HFF) ;
FOR I=1 TO 18
LPRINT CHR$ (&H85) ;
NEXT I
LPRINT CHR$ (&HFF) ;
RETURN
IMG2 ;
LPRINT CHR$ (&HFF) ;
LPRINT CHR$ (&HFF) ;
LPRINT CHR$ (&HFF) ;
FOR I=1 TO 18
LPRINTCHR$ (&H80) ;
LPRINTCHR$ (&H00) ;
LPRINTCHR$ (&H05) ;
NEXT I
LPRINT CHR$ (&HFF) ;
LPRINT CHR$ (&HFF) ;
LPRINT CHR$ (&HFF) ;
RETURN

```

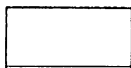
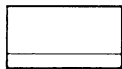
[Print Results]

GS * n1 n2 [d] n1 × n2 × 8

[Function] Defining the Download Bit Image

[Code] <1D>H<2A>H<n1><n2> [<d>] n1 × n2 × 8

[Range] { 1 =<n1 =< FF}
 { 1 =<n2 =< 30}
 { n1 n2 =< 51F} Data is described in Hex code.

[Outline] Defines downloading bit images of the number of dots specified by n1/n2.

- The numbers of dots are n1 x 8 in horizontal direction and n2 x 8 in vertical direction.
- d indicates bit image data.
- The download bit image thus defined remains effective until redefinition, ESC @ execution, ESC &, or power OFF takes place.

[Caution]

- A download character and a download bit image can not be defined simultaneously. With this command executed, defined content of a download character is cleared.
- Relations between the bit image data and the dot defined are shown below:
- If a download bit image is defined with this command while it is being printed (GS/), printing operation may become unstable (fluctuating print pitch).

[See Also] GS /

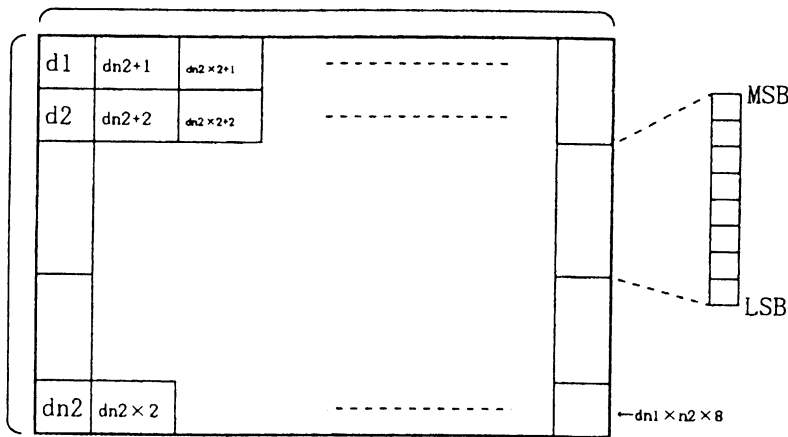

[Sample Program]

```

GOSUB IMG
LPRINT CHR$ (&H1D) + "/" + CHR$ (0);
LPRINT CHR$ (&H1D) + "/" + CHR$ (1);
LPRINT CHR$ (&H1D) + "/" + CHR$ (2);
LPRINT CHR$ (&H1D) + "/" + CHR$ (3);
END
IMG:
n 1 = 10 : n 2= 5
LPRINT CHR$ (&H1D) + "**";
LPRINT CHR$ (n1) + CHR$ (n2);
FOR J=1 TO n1*8
FOR I=1 TO n2
LPRINT CHR$ (J);
NEXT I
NEXT J
RETURN

```

[Print Results]

Normal Mode
 Double Width Mode
 Double Height Mode
 Quadruple Mode

GS / m

[Function] Printing the Download, Bit Image

[Code] <1D>H<2F>H<m>

[Range] {0 =< m =< 03} Data is described in Hex code.

[Outline] Prints download bit image in a mode specified by m.

- Modes can be selected by m are shown below.

m	Mode Name	Dot Density in Vertical Direction	Dot Density in Horizontal Direction
0	Normal mode	203 DPI	203 DPI
1	Double wide mode	203 DPI	101 DPI
2	Double high mode	101 DPI	203 DPI
3	Double wide/double high mode	101 DPI	101 DPI

- [Caution]**
- When data exist inside the print buffer, this command is ignored.
 - When a download bit image has not been defined, this command is ignored.
 - A portion of a download bit image exceeding one line length is not printed.
 - A download character and a download bit image cannot be defined simultaneously.
 - If a download bit image data is defined while it is being printed with this command, printing operation may become unstable (fluctuating print pitch).

[Default] • The initial value is not specified.

[See Also] GS *

[Sample Program]

[Print Results]

See Sample Program and Print Results for GS * on Page 52.

ESC v (Serial Interface Only)

[Function] Transmitting the printer status (Serial Type)

[Code] <1B>H<76>H

[Outline] Current printer status is transmitted.

- [Caution]**
- Status sent out consists of 1 byte whose content is as in the table below.
 - In DTR/DSR control, after revertible state of the host (DSR signal being in SPACE state) is confirmed, only 1 byte is transmitted. In XON/XOFF control, DSR signal state not being confirmed, only 1 byte is transmitted.
 - In DTR/DSR control, when the host is in unrespectable state (DSR signal being in MARK state), it waits until receptacle state is created.
 - In paper end (paper near end) status, this command may be unrespectable state due to BUSY state.

Remarks. This command is valid only for serial interface model.

Bit	Function	Value	
		0	1
0	Not defined		
1	Not defined		
2	Paper end	With paper	Without paper
3	Not defined		
4	Not used	Fixed to 0	—
5	Not defined		
6	Not defined		
7	Not defined		

[Sample Program]

```
OPEN "COM1: N81NN" AS #1;
PRINT #1, CHR$ (&H1B) + "v";
A$ = INPUT$ (1, #1);
CLOSE #1
```

ESC c5 n

[Function] Enabling/Disabling Panel Switches

[Code] <1B>H<63>H<35>H<n>

[Range] {0 =< n =< FF} Data is described in Hex code.

[Outline] Selecting the LF switch valid/invalid.

- "n" is valid only in the lowest bit (n0).
- "n" bit means the followings.

n0	Condition
0	LFSW valid.
1	LFSW invalid.

[Caution] When the panel switch is disabled with this command, the LF switch is disabled. Therefore, the paper cannot be fed by operating the LF switch.

[Default] • The initial value of n is "0".

[Sample Program]

```
LPRINT CHR$ (&H1B) + "c5" + CHR$ (0); .....When enabling the LF switch
LPRINT CHR$ (&H1B) + "c5" + CHR$ (1); .....When disabling the LF switch
```

GS :

[Function] Starting / Ending Macro Definition

[Code] <1D>H<3A>H

[Outline] Specifying starting / ending macro definition.
Means termination when received while defining a macro.

[Caution] Maximum content available for macro definition is 2048 bytes.
A portion exceeding 2048 bytes is not defined.

- Even with ESC @ (initialization of the printer) having been executed, defined content is not cleared. Therefore, it is possible to include ESC @ into the content of macro definition.
- Normal printing operation is carried out even while in macro definition

[Default] • Initially, Macro is not specified.

[See Also] GS ^

[Sample Program]

```
LPRINT CHR$ (&H1D) + “: ” ;
LPRINT "+——+" + CHR$ (&HA);
LPRINT " |    |" + CHR$ (&HA);
LPRINT "+——+" + CHR$ (&HA);
LPRINT CHR$ (&H1D) + “: “;
LPRINT CHR$ (&H1D) + " ^ “;
LPRINT CHR$ (2) + CHR$ (10);
LPRINT CHR$ (0);
```

[Print Results]

The diagram illustrates the output of the sample program. It shows two distinct periods of printing:

- Normal Printing during Macro Definition:** This period includes the first two lines of output: a line with a colon and space, and a line with a horizontal bar and a character.
- Printing during Macro Execution:** This period includes the next four lines of output: a line with vertical bars and a character, a line with a horizontal bar and a character, a line with a colon and a character, and a line with a character and a character.

GS ^ n1 n2 n3

[Function] Executing the Macro

[Code] <1D>H<5E>H<n1><n2><n3>

[Range] {0 =< n1 =< FF}
 {0 =< n2 =< FF}
 {0 =< 3 =< 1} Data is described in Hex code.

[Outline] Executing contents defined in macro.

- "n1~ n3" indicate as follows:

n1 : The number of times of macro execution

n2 : Waiting time on macro execution

Waiting time of n2 x 100msec is given for every execution.

n3 : Macro execution mode

n3	Mode
0	Continuous execution
1	Execution by LFSW

Continuous execution: The Macro is executed n1 times continuously at the time intervals specified by n2.

Execution by FEED S: After waiting for lapse of time specified by n2, the ALAME LED flickers and the LF switch is waited to be pressed. When it is pressed, the macro is executed once.
 This action is repeated n1 times.

- [Caution]**
- When this command is received while in macro definition, suspension of macro definition is indicated. At this time, the defined content is cleared.
 - No execution takes place when macro is held undefined or n1=0.
 - While in macro execution with n3=1, paper feed with the LF SW is not available.

[Default] • Initially, this command is not specified.

[See Also] GS :

[Sample Program]

[Print Results]

See Sample Program and Print Results for GS : on Page 57.

ESC i (When Using Auto Paper Cutter)

[Function] Full Cut

[Code] <1B>H<69>H

[Outline] Activating auto cutter unit (Full cut)

- [Caution]**
- This is valid only when n is inputted at the beginning of line.
 - Prior to cutting the paper, feed the paper from the printing position to beyond the paper cutting position of the cutter. Otherwise, the character just after print will remain on this side of the cutter.

[Sample Program]

```
LPRINT "AAAAA";
LPRINT CHR$ (&H1B) + "J";
LPRINT CHR$ (150);
LPRINT CHR$ (&H1B) + "i";
LPRINT "AAAAA";
LPRINT CHR$ (&H1B) + "J";
LPRINT CHR$ (150);
LPRINT CHR$ (&H1B) + "i";
```

[Print Results]

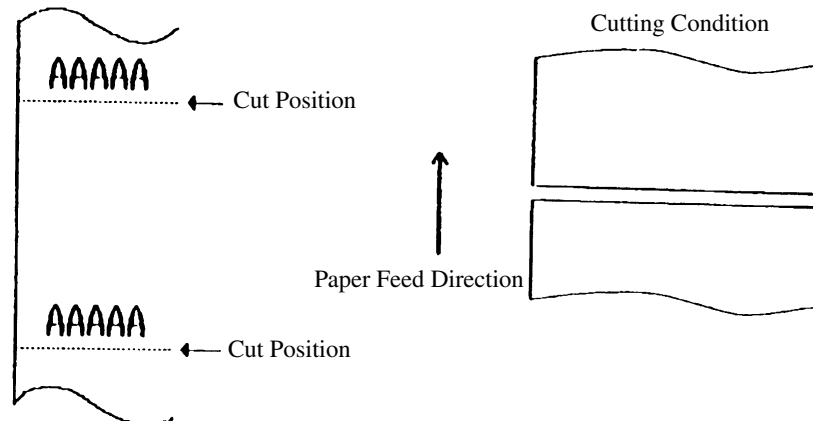

ESC m (When Using Auto Paper Cutter)

[Function] Partial Cut

[Code] <1B>H<6D>H

[Outline] Activating auto cutter unit (Partial cut)

[Caution]

- This is valid only when n is inputted at the beginning of line.
- Prior to cutting the paper, feed the paper from the printing position to beyond the paper cutting position of the cutter. Otherwise, the character just after print will remain on this side of the cutter.

[Sample Program]

```
LPRINT "AAAAA";
LPRINT CHR$ (&H1B) + "J";
LPRINT CHR$ (150);
LPRINT CHR$ (&H1B) + "m";
LPRINT "AAAAA";
LPRINT CHR$ (&H1B) + "J";
LPRINT CHR$ (150);
LPRINT CHR$ (&H1B) + "m";
```

[Print Results]

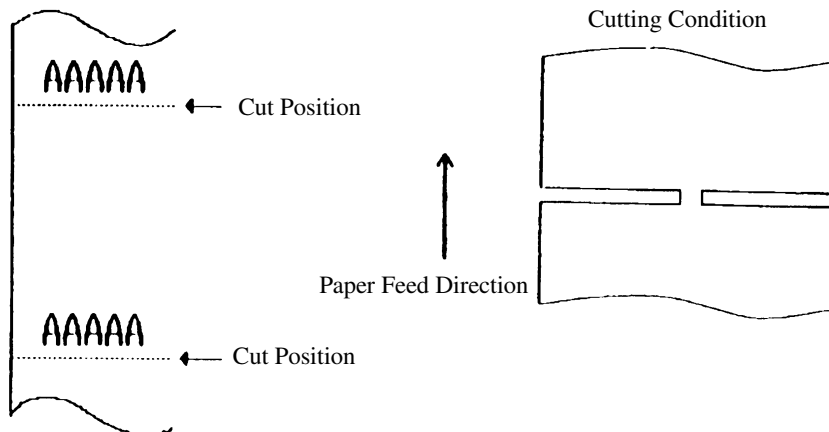

GS H n

[Function] Selecting of Printing Position of HRI Code

[Code] <1D>H<48>H<n>

[Range] {0 =< n =< 3} Data is described in Hex code.

[Outline] Selecting printing position of HRI code in printing bar codes.

- "n" means the followings.

n (Hex)	Printing Position
0	No printing
1	Above the bar code
2	Below the bar code
3	Both above and below the bar code

The HRI code refers to the bar code-turned characters so that you can read them.

[Caution] The HRI code is printed in the font selected with GS f. Specify before the GS k command.

[Default] • The initial value of n is "0".

[See Also] GS f

[Sample Program]

```
LPRINT CHR$ (&H1B) + "3" + CHR$ (5);
LPRINT CHR$ (&H1D) + "h" + CHR$ (50);
LPRINT CHR$ (&H1D) + "H" + CHR$ (0);
GOSUB BC
LPRINT CHR$ (&H1D) + "H" + CHR$ (1);
GOSUB BC
LPRINT CHR$ (&H1D) + "H" + CHR$ (2);
GOSUB BC
LPRINT CHR$ (&H1D) + "H" + CHR$ (3);
GOSUB BC
END
BC:
LPRINT CHR$ (&H1D) + "k";
LPRINT CHR$ (4);
LPRINT "12" + CHR$ (0);
LPRINT CHR$ (&HA);
RETURN
```

[Print Results]

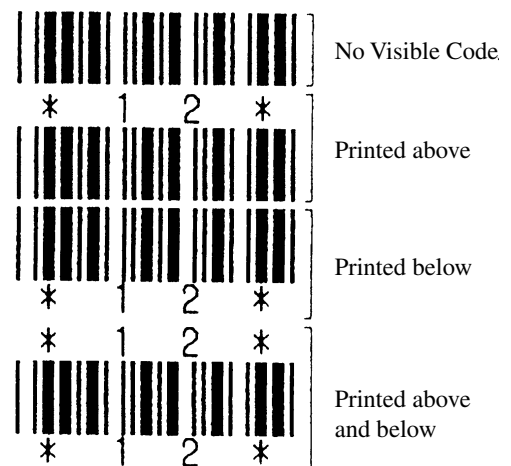

GS f n

[Function] Selecting the font of HRI code

[Code] <1D>H<66>H<n>

[Range] n = 0, 1

[Outline] Selecting the font of HRI code in printing bar code.
The type of font can be printed by selecting n is as follows.

The HRI code refers to the bar code-turned characters so that you can read them.

n	Font
0	Font A
1	Font B

[Caution] The HRI code is printed at the position specified with GS h on page 63.

[Default] The initial value of n is "0".

[See Also] GS H

[Sample Program]

```
LPRINT CHR$ (&H1D) + "h" + CHR$ (50);
LPRINT CHR$ (&H1D) + "H" + CHR$ (2);
LPRINT CHR$ (&H1D) + "f" + CHR$ (0);
GOSUB BC
LPRINT CHR$ (&H1D) + "f" + CHR$ (1);
GOSUB BC
END
BC:
LPRINT CHR$ (&H1D) + "k";
LPRINT CHR$ (4);
LPRINT "123" + CHR$ (0);
LPRINT CHR$ (&HA);
RETURN
```

[Print Results]

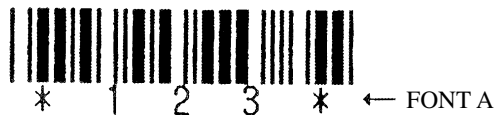

GS h n

[Function] Selecting the height of the Bar Code

[Code] <1D>H<68>H<n>

[Range] { 1 =< n =< FF } Data is described in Hex code.

[Outline] Selecting bar code height.
n denotes the number of dots in the vertical direction.

[Default] • The initial value of n is "162".

[Sample Program]

[Print Results]

See Sample Program and Print Results for GS w on page 68.

GS k n [d] k NUL

[Function] Printing the Bar Code

[Code] <1D>H<6B>H<n> [< d>] k <00>H

[Range] {0 =< n =< 7} Data are described in Hex code.

[Outline] Specifying a type of bar code and printing bar codes.

- The beginning of line is considered as the next printing start position.
- Depending on the value of n, the following bar code can be selected.

d indicates a character code to be printed and k indicates the number of character to be printed.

n (Hex)	Bar Code System	Maximum Columns
0	UPC-A	---
1	UPC-E	---
2	JAN13 (EAN)	---
3	JAN 8 (EAN)	---
4	CODE 39	13
5	ITF	22
6	CODABAR (NW-7)	17
7	CODE 128	15

- [Caution]**
- When data being held in the print buffer, this command is ignored.
 - Regardless of the specified feed pitch, this command feeds the paper to be required to print a bar code.
 - If the character code d cannot be printed in the respective bar code system, the bar code so far will be printed, processing the subsequent data as normal data.
 - When a bar code whose number of characters to be printed is fixed has been selected, the number of characters k have to be always made equal to the number of characters to be printed. (The bar code is not printed when not matching.)
 - When the horizontal direction exceeds one line length, the excess part is not printed.

- [Default]**
- The initial value is not specified.

[Description of Bar Codes] <For print examples, see Page 67. >

- UPC-A This bar code, consisting of numerals only, has a fixed length of 12 column; a 11-column number entered from the host or application software plus a check column(12th column) automatically calculated inside the printer. If the 12th-column numeral is sent from the host, the entire bar code will be printed as it is.
- UPC-E This bar code, consisting of numerals only, has a fixed length of 8 column; the first number system character is "0" stationary. A 12-column numeral entered from the host or application software is compressed to 8 columns with a check column and printed. The 12th-column check column is automatically calculated inside the printer and sent from the host, the entire bar code will be printed, compressed to 8 columns.
- JAN13(EAN) This bar code, consisting of numerals only, has a fixed length of 13 column; a 12-column number entered from the host or application software plus a check column(13th column) automatically calculated inside the printer. If the 13th-column numeral is sent from the host, the entire bar code will be printed as it is.
- JAN8(EAN) This bar code, consisting of numerals only, has a fixed length of 8 column; a 7-column number entered from the host or application software plus a check column(8th column) automatically calculated inside the printer. If the 8th-column numeral is sent from the host, the entire bar code will be printed as it is.
- CODE39 This bar code, consisting of uppercase alphabets and numerals, has a variable length of column. A start/stop code "*" is automatically added by the printer. Available characters include a space and "\$, %, *, +, -, ·, /, 0, 1, 2, 3, 4, 5, 6, 7, 8, 9," and uppercase alphabets.
- ITF This bar code, consisting of numerals only, has a variable length of even column. If an odd-column code is transferred, nothing will be printed.
- CODABAR (NW-7)
This bar code, consisting of alpha numerals, has a variable length of column. Available characters include "0, 1, 2, 3, 4, 5, 6, 7, 8, 9, A, B, D, D, \$, +, -,., /, :." A start/stop code is required; any one of A, B, C, and D is used.
- CODE128
- This bar code consists of all of 128 ASCII code characters and has a variable length of column. This printer supports the code subsets A, B, and C. By prefixing a transfer code with any one character of A, B, and C, you can select the code subset to start from. If not prefixed with A, B, or C, the code subset B will be selected.
 - The code subset A is the bar code consisting of standard uppercase alphabets, numerals, symbols, and special codes.
 - The code subset B is the bar code consisting of standard uppercase/lowercase alphabets, numerals, symbols, control codes, and special codes.
 - The code subset C is the bar code consisting of special characters and 100 kinds of numbers ranging from 00 to 99.
 - The check column automatically calculated inside the printer is added to the end of the entered column to be printed.

- Processing of the special characters

The characters above the ASCII code number 96 are considered special characters. The following lists the converted characters for entering these characters.

ASCII Code	Converted Character	Subset Code	Subset Code B	Subset Code C
96	80h	FNC 3	FNC 3	-N/A-
97	81h	FNC 2	FNC 2	-N/A-
98	82h	SHIFT	SHIFT	-N/A-
99	83h	CODE C	CODE C	-N/A-
100	84h	CODE B	FNC 4	CODE B
101	85h	FNC 4	CODE A	CODE A
102	86h	FNC 1	FNC 1	FNC 1

The following exemplifies a selection of the code subset as a method to utilize the special characters.

<Selection of Code Subset>

- Initial selection: Enter any one character of A, B, and C.
- Conversion on the way: Enter any one character of 82h through 85h

Example) When initially testing with the code subset B, and then, printing the bar code, "123," with the code subset A

• Input code :

• Bar code data : <CODE B>TEST<CODE A>123

[Sample Program]

```
LPRINT CHR$ (&H1D) + "H" + CHR$ (2);
LPRINT CHR$ (&H1D) + "k";
LPRINT CHR$ (4);
LPRINT "123" + CHR$ (0);
```



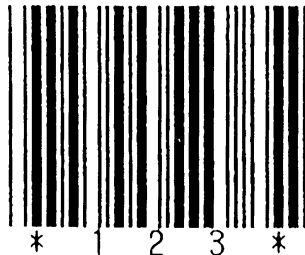



[Print Results]



When the data "123" is printed with the code 39

[Description of Bar Codes]

UPC-A, UPC-E, JAN-13 (EAN), JAN-8 (EAN), CODE39, ITF, CODABAR, CODE128

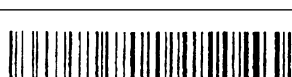
Type	Print Sample	Outline of Symbol	Max. column
UPC-A		12-column fixed-length bar code consisting of numerals only	—
UPC-E		8-column fixed-length bar code consisting of numerals only. Abbreviated version of UPC-A	—
JAN-13		13-column fixed-length bar code consisting of numerals only	—
JAN-8		8-column fixed-length bar code consisting of numerals only	—
CODE39		Variable-length bar code consisting of alphabets and numerals. The start/stop code "*" is automatically added.	13
ITF		Even-column variable-length bar code consisting of numerals only	22
CODABAR (NW-7)		Variable-length bar code consisting of alpha numerals. Any one of A, B, C, and D is required as the start/stop code.	17
CODE128		Variable-length bar code consisting of all 128 ASCII code characters.	15

Printing is done depending on bar code specification type, number of print column, bar code height, width (Magnification), visible code presence, and bar code data specification.

GS w n

[Function] Selecting the horizontal size (Scale factor) of the Bar Code

[Code] <1D>H <77>H<n>

[Range] {2 =< n =< 4} Data is described in Hex code.

[Outline] Selecting bar code width.
n denotes the number of dots in fine element width.

[Default] • The initial value of this width is "3".

[Sample Program]

```
LPRINT CHR$ (&H1D) + "h" + CHR$ (30);
LPRINT CHR$ (&H1D) + "w" + CHR$ (2);
GOSUB BC
LPRINT CHR$ (&H1D) + "h" + CHR$ (50);
LPRINT CHR$ (&H1D) + "w" + CHR$ (3);
GOSUB BC
LPRINT CHR$ (&H1D) + "h" + CHR$ (80);
LPRINT CHR$ (&H1D) + "w" + CHR$ (4);
GOSUB BC
END
BC:
LPRINT CHR$ (&H1D) + "k";
LPRINT CHR$ (4);
LPRINT "12" + CHR$ (0);
RETURN
```

[Print Results]

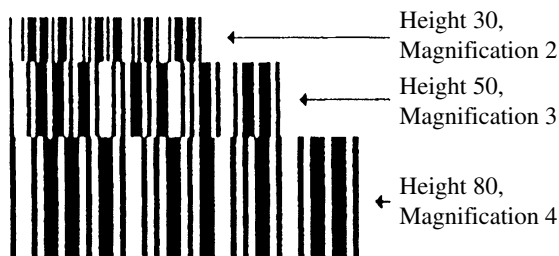

ESC = n**[Function]** Data Input Control**[Code]** <1B>H<3D>H<n>**[Range]** {0 =< n =< FF} Data is described in Hex code.**[Outline]** Selecting equipment in which data input from the host is effective.

- Each bit of n indicates as follows:

Bit	Equipment	Value	
		0	1
0	Printer	Invalid	Valid
1	Not defined		
2	Not defined		
3	Not defined		
4	Not defined		
5	Not defined		
6	Not defined		
7	Not defined		

- When the printer has not been selected, this printer abandons all the received data until it is selected by this command.

[Caution]

- Even when the printer has not been selected, it can become BUSY state through printer operation.
- When the printer is deselected, this printer discards all the data until it is selected with this command.

[Default]

- The initial value of n is "1".

[Sample Program]

```
LPRINT "AAAAA";
LPRINT CHR$ (&H1B) + "=" + CHR$ (0);
LPRINT "aaaa" + CHR$ (&HA);
LPRINT CHR$ (&H1B) + "=" + CHR$ (1);
LPRINT "AAAAA" + CHR$ (&HA);
```

[Print Results]

```
A A A A A A A A A
      ↑
a a a a a is not printed
```

ESC @

[Function] Initializing the Printer

[Code] <1B>H<40>H

[Range] Clears data stored in the print buffer and brings various settings to the initial state (Default state).

- [Caution]**
- Data inside the internal input buffer are not cleared.
 - Dip switches setting are red once again.

[Sample Program]

```
LPRINT CHR$ (&H1B) + " !" + CHR$ (&H30) ;  
LPRINT CHR$ (&H1B) + "V" + CHR$ (1);  
LPRINT "AAA" + CHR$ (&HA);  
LPRINT CHR$ (&H1B) + "@";  
LPRINT "AAA" + CHR$ (&HA);
```

[Print Results]

```
  A  A  A  
A A A
```

DC2 A n

[Function] Selecting the Print drive system

[Code] <12>H<41>H<n>

[Range] {0 =< n =< FF}

[Outline] Selecting the Fixed division system or the Variable division system.

- "n" is valid only for the lowest bit (n0).

n0	Print Drive System
0	Fixed division number system
1	Variable division number system

[Default] The initial value of n is specified by Jumper (J5).

12. CHARACTER CODE TABLE

12.1 International

	0	1	2	3	4	5	6	7	8	9	A	B	C	D	E	F
0	NUL		SP	@	P	·	·	p	Ç	E	à	☐	⊥	⊥	α	≡
1		ION	!	1	Q	a	a	q	ü	æ	í	☐	⊥	⊥	β	±
2			"	2	R	b	b	r	é	Æ	ó	☐	⊥	⊥	Γ	≈
3		XOF	#	3	C	c	c	s	á	ô	ú		⊥	⊥	π	≡
4			\$	4	D	d	d	t	ä	ö	ñ	⊥	⊥	⊥	Σ	
5			%	5	E	e	e	u	à	ò	Ñ	⊥	⊥	⊥	σ	⊥
6			&	6	F	f	f	v	á	û	ä	⊥	⊥	⊥	μ	÷
7			'	7	G	g	g	w	ç	ù	ö	⊥	⊥	⊥	τ	≈
8			(8	H	h	h	x	é	ÿ	í	⊥	⊥	⊥	Φ	o
9	HT)	9	I	i	i	y	è	ó	í	⊥	⊥	⊥	θ	·
A	LF		*	:	J	j	j	z	è	ü	í		⊥	⊥	Ω	·
B		ESC	+	;	K	k	k	{	ï	φ	½	⊥	⊥	⊥	δ	√
C		FS	,	<	L	l	l		í	£	¼	⊥	⊥	⊥	∞	n
D		GS	-	=	M	m	m	}	ì	¥	í	⊥	⊥	⊥	φ	2
E			.	>	N	^	~	~	À	ℳ	«	⊥	⊥	⊥	ε	■
F			/	?	O	_	o	SP	Á	f	»	⊥	⊥	⊥	∩	SP

12.3 International Character Set

	COUNTRY	23	24	40	5B	5C	5D	5E	60	7B	7C	7D	7E
0	U.S.A.	#	\$	@	[\]	^	`	()	~
1	France	#	\$	a	·	ç	§	^	`	é	ù	è	¨
2	Germany	#	\$	§	λ	ö	ü	^	`	a	o	u	ß
3	U.K.	£	\$	@	[\]	^	`	()	~
4	Denmark I	#	\$	@	Æ	Ø	Λ	^	`	æ	ø	å	~
5	Sweden	#	☐	é	λ	ö	λ	ü	é	a	o	a	u
6	Italy	#	\$	@	·	\	é	^	ù	a	ò	è	ì
7	Spain	₧	\$	@	i	ñ	¿	^	`	~	n)	~
8	Japan	#	\$	@	[Y]	^	`	()	~
9	Norway	#	☐	é	Æ	Ø	Λ	ü	é	æ	ø	å	u
10	Denmark II	#	\$	é	Æ	Ø	Λ	ü	é	æ	ø	å	u

APPENDIX 1. BLOCK DIAGRAM

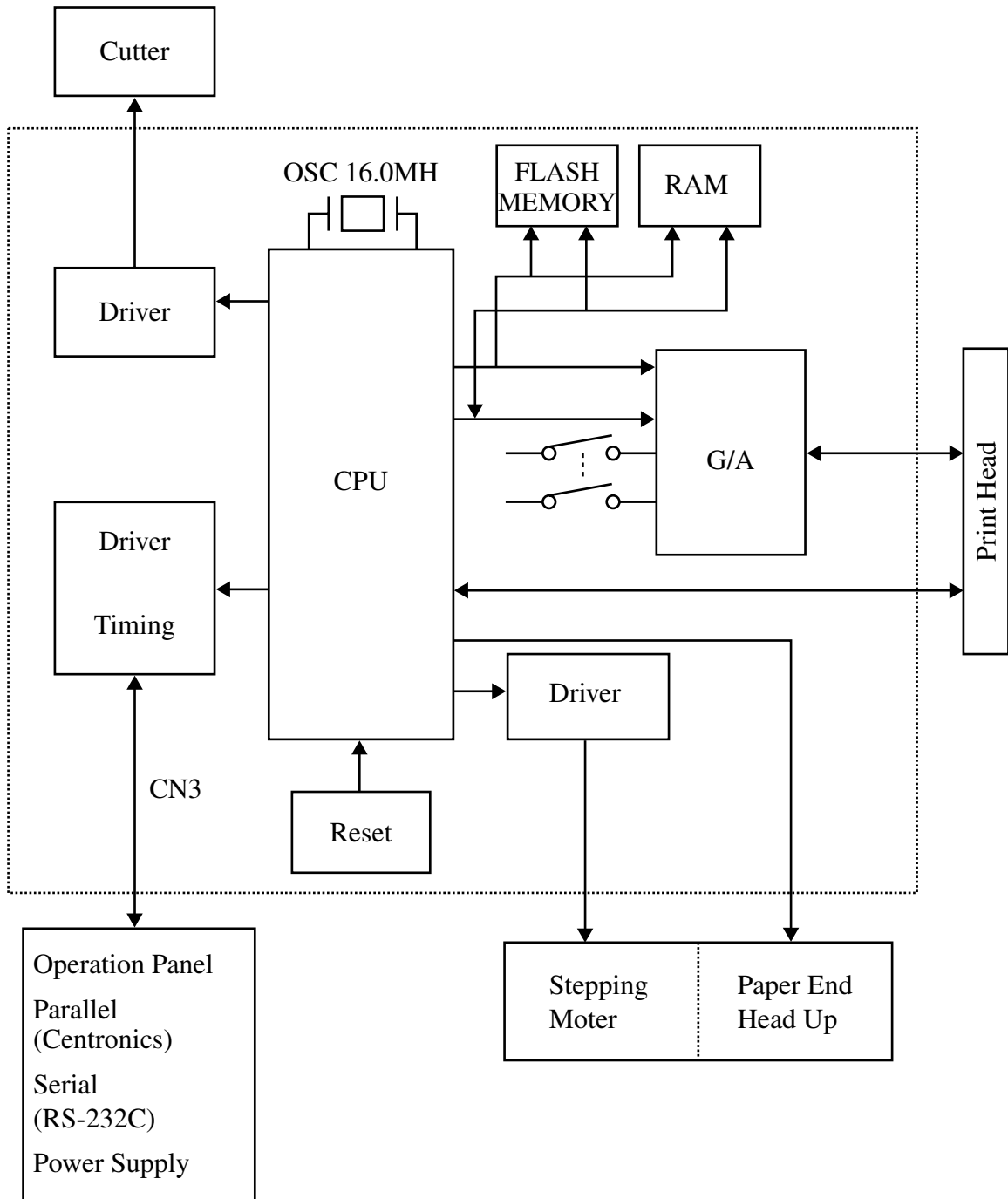

APPENDIX 2. Outer Dimension

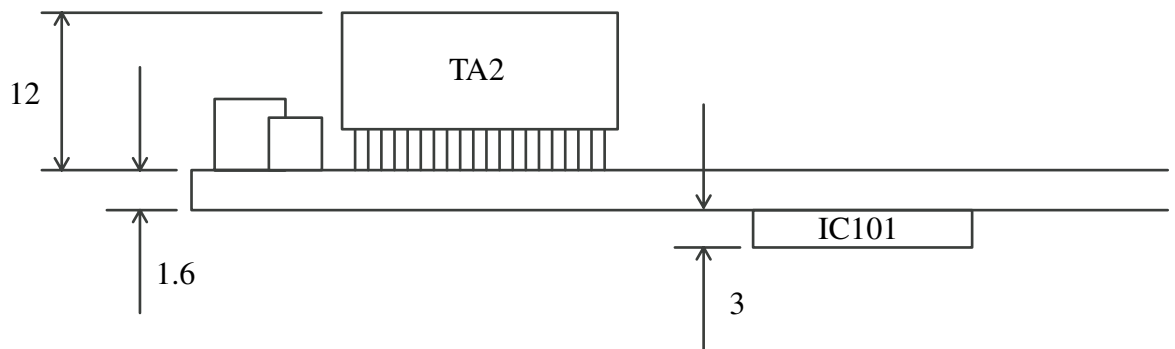
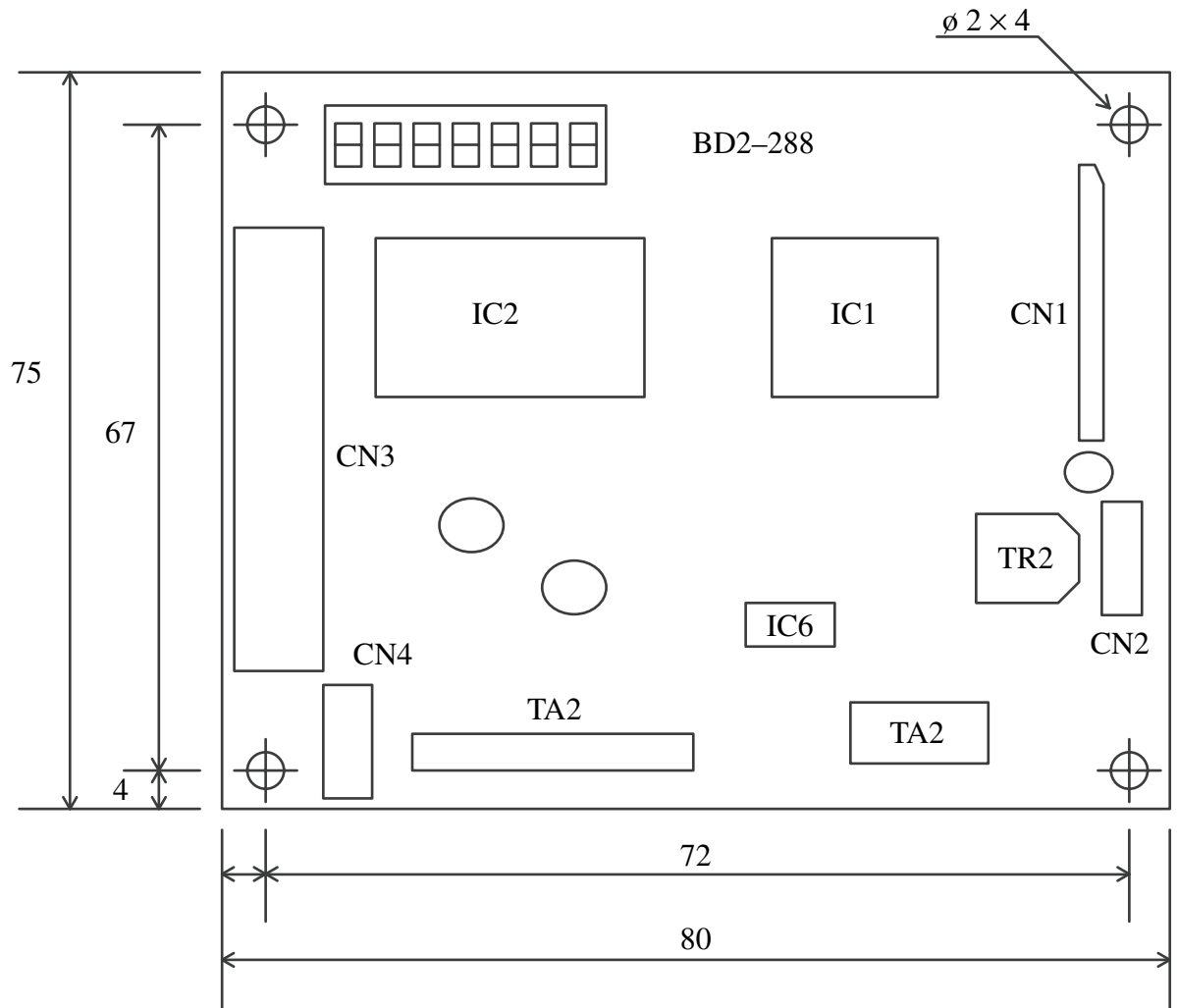

(Unit : mm)