

***TECHNICAL
INFORMATION***

**CITIZEN QUARTZ
Cal.No.925 ※※**

§ 1. OUTLINE





This is a multi-function type digital quartz crystal watch for ladies, which is developed to follow Cal. No. 9110 with addition of the new functions of the stop-watch and the dual time.

§ 2. FEATURES

- 1) The easy-to-see display with a unique design plus a simplified operation in spite of the multi-function structure.
- 2) The movement features a reduced number of component parts which are collected with just two pieces of screws, thus facilitating an easy disassembling and assembling.
- 3) The fully automatic calendar including the leap years (years possible to set up to 1970~2009).
- 4) About 2 years of the power cell life (with lamp lighting of about 5 sec. per day).
- 5) With the illumination lamp

§3. SPECIFICATIONS

Caliber No.		9250A
Movement		Size : 17.6mm ϕ
		Thickness : 4.73mm
Oscillation		32,768Hz
Accuracy		± 15 sec./month at normal temperatures
Display system		Matrix-driven FE twist type nematic liquid crystal display
Display information	Time display	Hour, minute, second and "A/P" mark
	Calendar display	Month, date, day, year (at setting time) and "DATE" mark
	Stopwatch	Minute, second and 1/100 sec. (up to 19'59"99). Hour, minute and second (up to 11:59'59" after 20 min.) With "LAP" and "  " mode marks
	Dual time	Hour, minute "A/P" and "  " mode marks
Effective temperature range		0°C ~ +60°C (+32°F ~ 140°F)
Integrated circuit		C/MOS-LSI (1 unit)
Adjustment of time		By trimmer condenser
Additional devices		<ul style="list-style-type: none"> ●Stopwatch ●Dual time ●Instant manual return ●Fully automatic calendar (incl. leap years), years set up to 1970 ~ 2009 ●Lamp
Power cell		Silver oxide power cell : 1 unit Parts No. : 280-13 Nominal voltage : 1.55V Capacity : 45mAH Size : 7.9mm ϕ x 3.6mm Life time : About 2 years

§ 4. HANDLING INSTRUCTIONS (The flashing areas are shown in the red color.)

1) Nomenclature of each part



- Ⓛ Light button: For lamp lighting, instant manual return and start/stop of stopwatch
 - Ⓜ Mode button: For changing of functions
 - Ⓡ Read/set button: For switching/correction of display plus lap and reset of stopwatch
 - Ⓢ Select button: For selection of correcting digit
 - Stopwatch mode mark
 - Dual time mode mark
- LAP Lap of stopwatch and A (AM)/P (PM) of time display

2) How to switch and read display

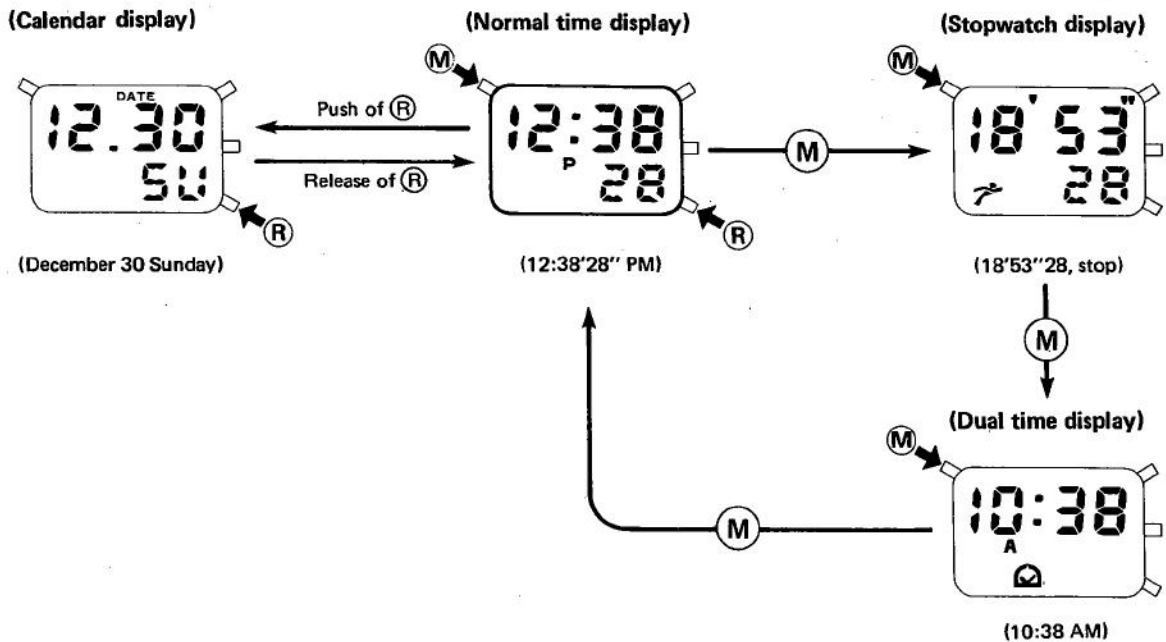

The calendar is displayed while Ⓡ button is pressed in the normal time display with every push of Ⓜ button in the normal time display, the display changes in that order:

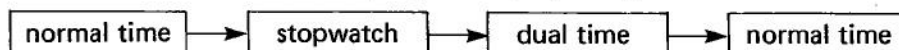

(Note) The displays are as follows after replacement and reassembling of the power cell.

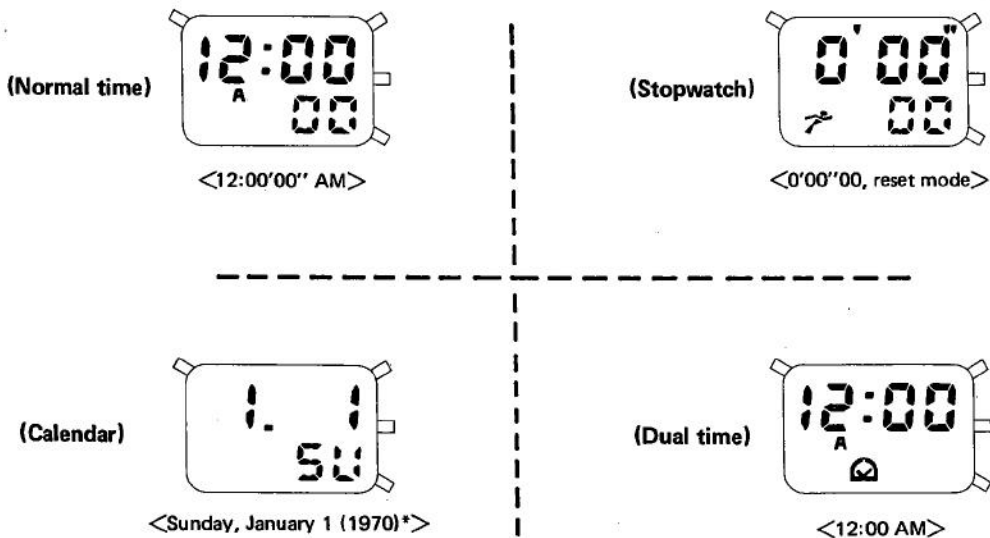

*The year is displayed in its last two digits (70) in the display column of the "second" when the calendar is corrected. So set the correct year.

3) How to set time and calendar

With push of **(S)** button, the area to be corrected is called out. And then **(R)** button is pushed to correct the display. (The area to be corrected has flashing as shown by **(O)** mark.)

The setting is carried out in the sequence of **(1)** → **(15)** as shown next page. (For the individual setting of a certain digit, **(S)** button is pushed several times to call out the digit to be corrected and then **(R)** button is pushed for correction.)

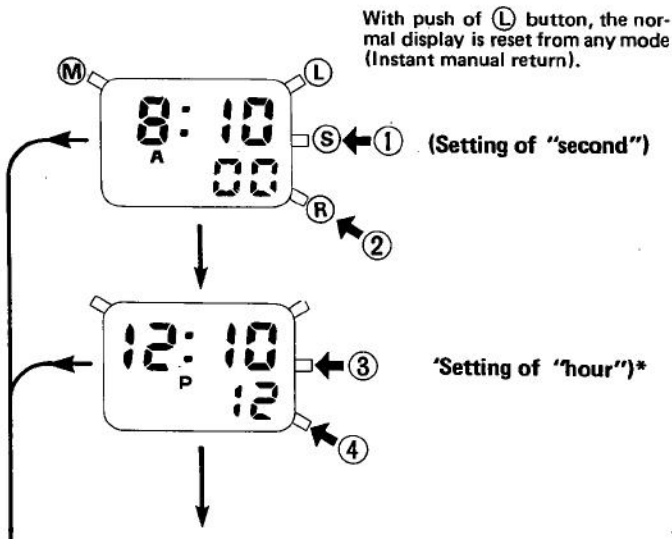

- ① With push of **(S)** button, under the state of the normal time display the "second", flashes.
- ② With push of **(R)** button, the time is reset to "0-second". (The "minute" is carried when the "second" reads 30 ~ 59.)
- ③ With push of **(S)** button, the "hour" and "A" or "P" have flashing.
- ④ With push of **(R)** button, the "hour" is carried by one. Make sure "A" (AM) or "P" (PM).

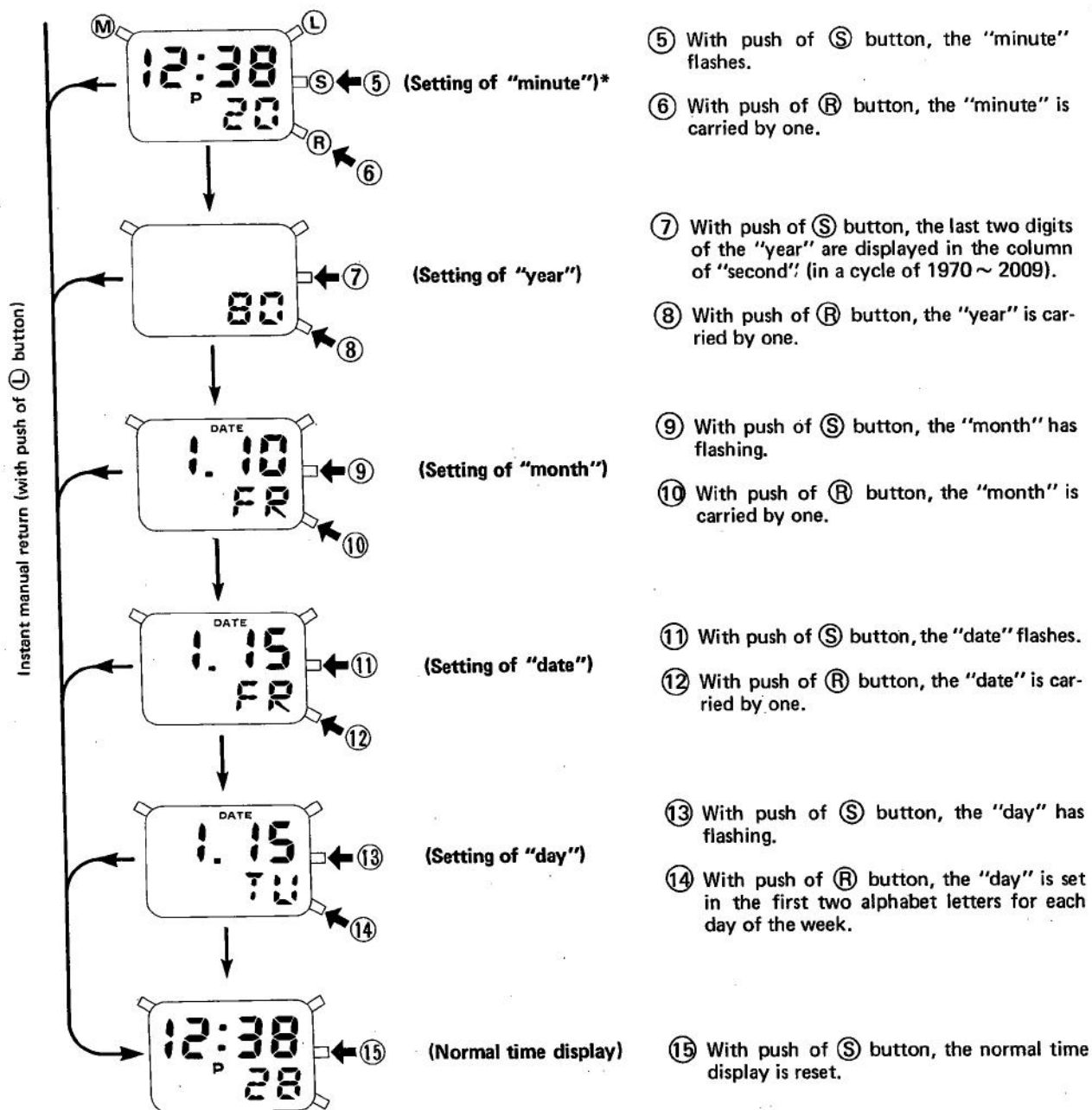

*The Citizen digital watches usually feature the time setting sequence as "second → minute → hour". With this caliber, however, the different sequence is applied as "second → hour → minute".

4) Operation of stopwatch

(1) Display marks of stopwatch

↗ Stopwatch mode mark

LAP Lap mark (no flashing at lap stop)

- " Display up to 0~19'59"99. The digits of "minute" and "second" are indicated by " ' " and " " ", respectively with only figures for the time display of "1/100 sec."
- Displayed between "hour" and "minute" as identical to the normal time display up to 20 min. ~ 11:59'59".

(2) Resetting method (The resetting must be given for use.)

The display when the normal time display is switched to the stopwatch mode indicates the state given by switching the stopwatch mode to another mode. However, in case the stopwatch mode is switched to another mode under the lap running or lap stop state, the lap mode is cancelled to change the lap running and lap stop states to the running and stop states respectively. Thus the three modes of the reset, stop and running modes are displayed as shown below within the dotted-line box.

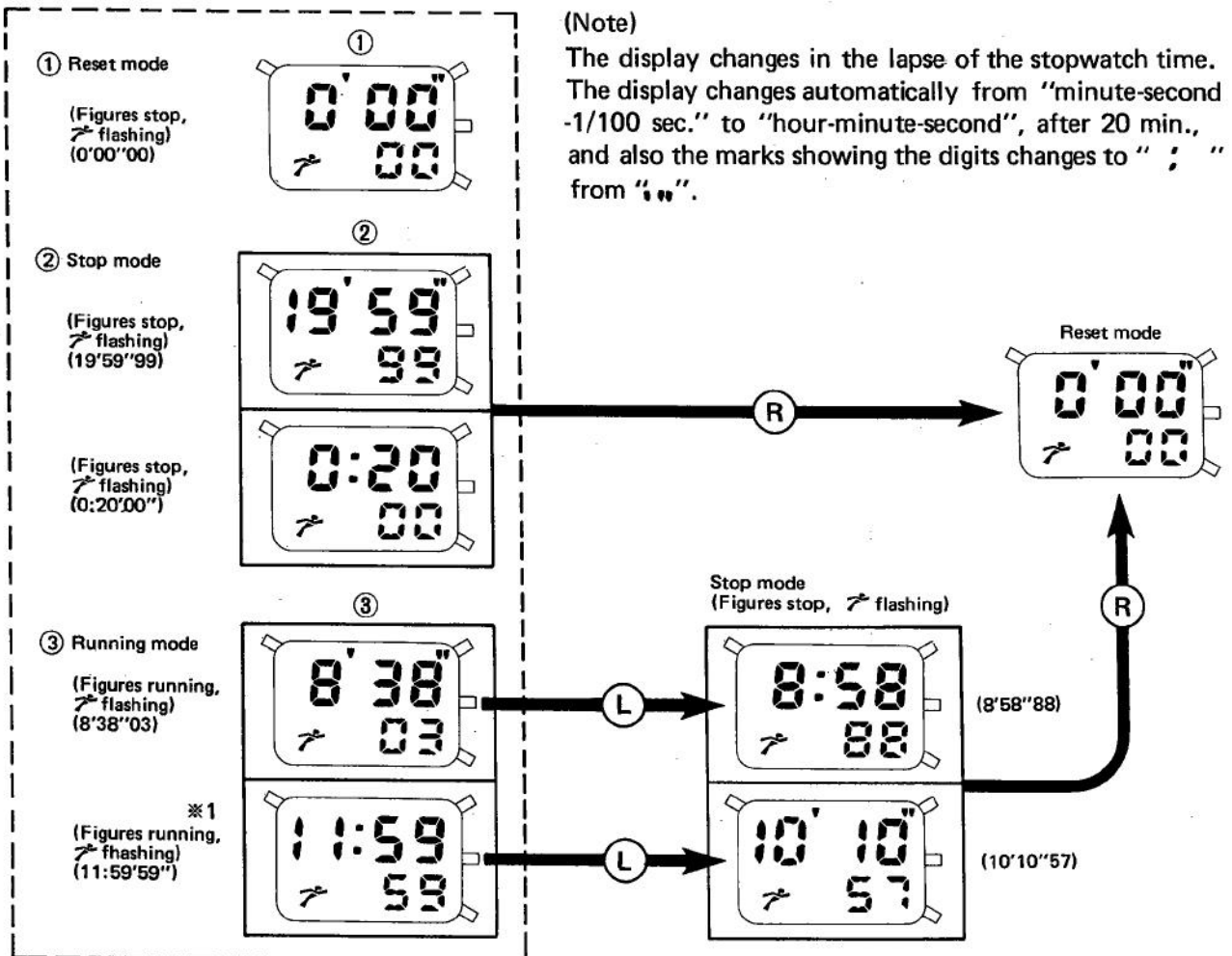

*1. As the count time exceeds 12 hours by the stop, the counting is given again from the reset mode.

(3) Switching to each state of display under stopwatch mode

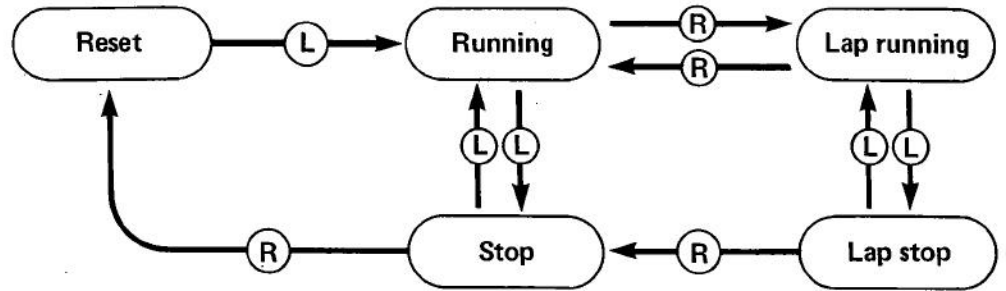

(4) Simple/Cumulative counting method

With every push of (L) button, the start and stop are repeated alternately for timing. Thus the cumulative timing is possible continuously up to 11:59'59". After this, the display returns to the reset mode again to have the next start, which is repeated until the stop mode is given.

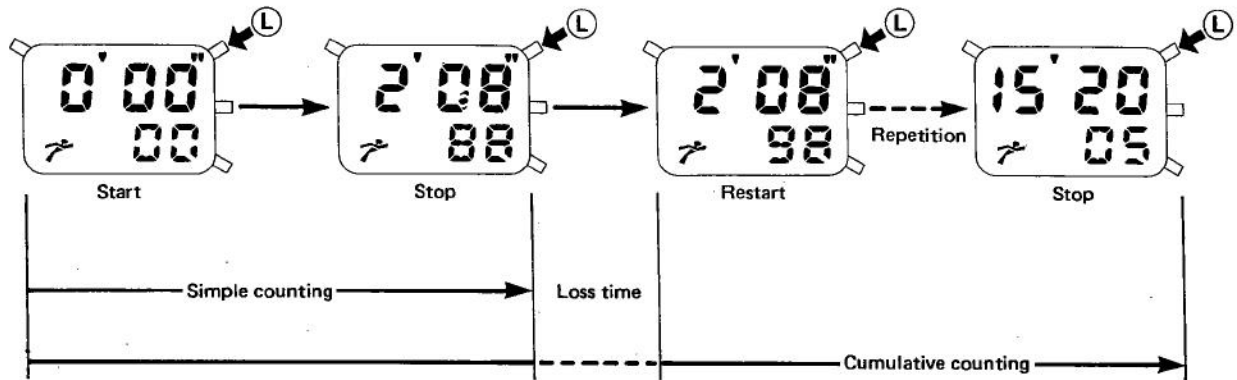

(5) Timing of lap time (par-way time)

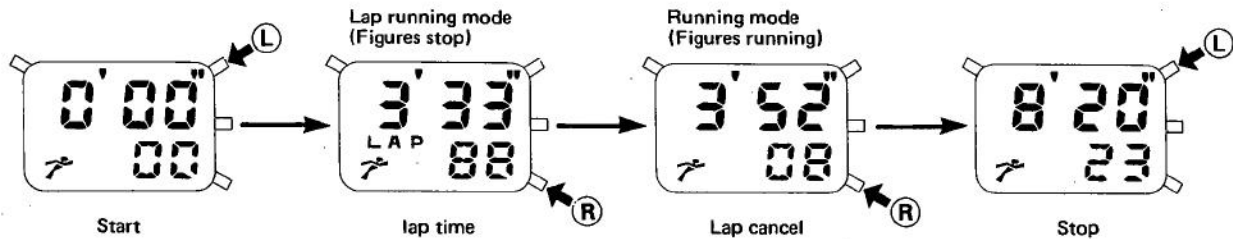

(6) Timing of 1st and 2nd places

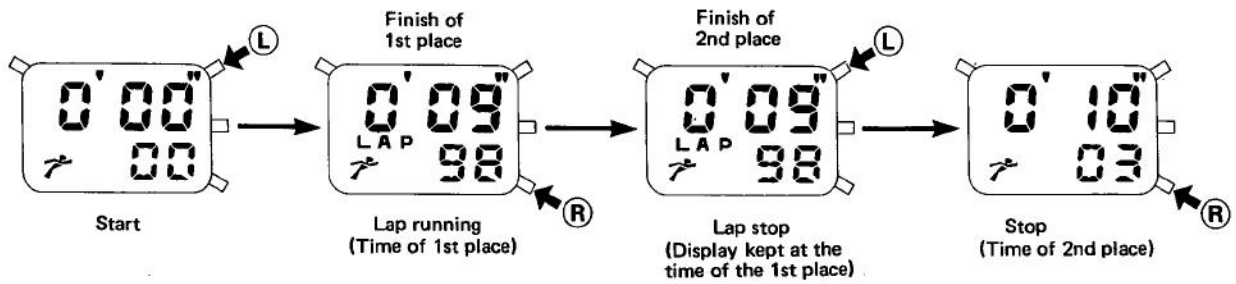

*In case the stopwatch is under the running state in the normal time display mode, the mode mark of the stopwatch is displayed.

5) Operation of dual time

(1) Call-out of dual time mode and reset to normal time display

With push of (M) button twice in the normal time display mode, the display is switched to the dual time mode via the stopwatch mode. And with push of (M) button once in the "normal display" of the dual time, the normal time display is reset.

(2) Setting of time

With push of (S) button, the area to be corrected is called out. And then (R) button is pushed to carry out the correction of time (in sequence of ① → ⑦).

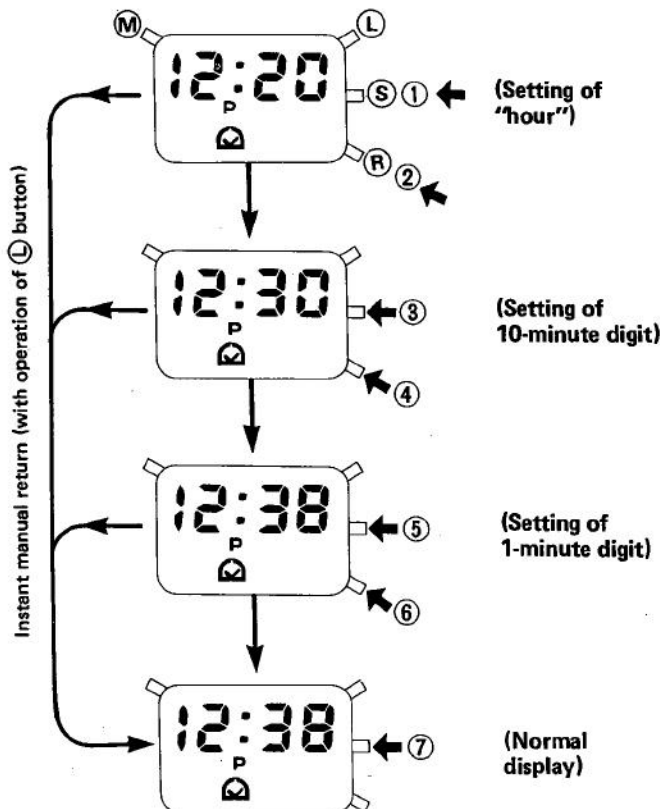

① With push of (S) button, the "hour" plus "A" or "P" have flashing.

② With push of (R) button, the "hour" is set by making sure of "A" (AM) or "P" (PM).

③ With push of (S) button, the "10-minute digit" flashes.

④ With push of (R) button, the "10-minute digit" is set.

⑤ With push of (S) button, the "1-minute digit" flashes.

⑥ With push of (R) button, the "1-minute digit" is set.

⑦ With push of (S) button, the normal display of the dual time is reset.

Note

*In case the "non-existing" date is set when correcting the time and calendar, the date is kept on display even after switching to other displays. So the non-existing date must be corrected to the right calendar display.

(Ex.)

1979 ← (The year is displayed only at the correcting time of the time and calendar.)

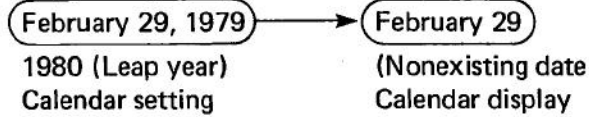

*The illumination lamp goes on with push of (L) button in any mode (including the correcting mode).

§5. Constitution of Circuit

