



User's Guide

Black-and-White Raster Plotter

LP-1020

LP-1020L

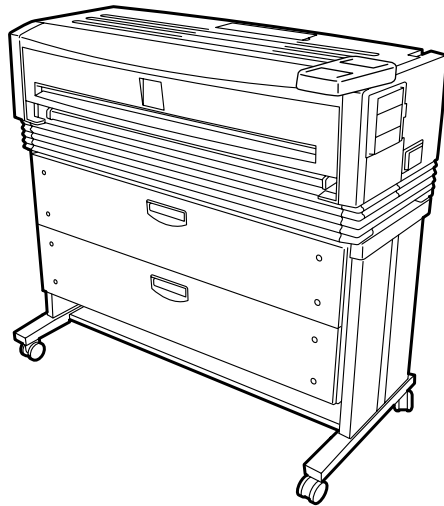

Read this User's Guide to use the plotter safely and properly. Keep this manual in a place where you can quickly access it at any time.

Seiko I Infotech Inc.

U00107742300 November 2007

U00107742301 December 2007

©Seiko I Infotech 2007

Reprinting of this manual without permission is prohibited.
The content of this manual may be changed without notice.

D-SCAN is a registered trademark of Seiko Instruments, Inc.

Ethernet is a registered trademark of Xerox, Inc.

HP is a registered trademark of Hewlett-Packard (U.S.A.)

MICRO CADAM is a trademark of CADAM, Inc. (U.S.A.)

Athlon is a trademark of Advanced Micro Device, Inc.

Intel, Pentium and Core are registered trademarks or a trademark of Intel Corporation.

This equipment has been tested and found to comply with the limits for a Class A digital device, pursuant to Part 15 of the FCC Rules. These limits are designed to provide reasonable protection against harmful interference when the equipment is operated in a commercial environment.

This equipment generates, uses, and can radiate radio frequency energy and, if not installed and used in accordance with the instruction manual, may cause harmful interference to radio communications. Operation of this equipment in a residential area is likely to cause harmful interference in which case the user will be required to correct the interference at his own expense.



Durch die Kennzeichnung dieses Produktes mit dem CE-Zeichen erklärt Seiko den folgenden Direktiven der Europäischen Union zu entsprechen (mit Wirkung vom siehe Datum):

Januar 1996:- EG-Direktive 73/23/EEC ergänzt durch EG-Direktive 93/68/EEC, Angleichung der Gesetze der einzelnen Mitgliedsstaaten bezüglich Geräten mit niedriger Betriebsspannung.

Januar 1996:- EG-Direktive 89/336/EEC, Angleichung der Gesetze der einzelnen Mitgliedsstaaten bezüglich elektromagnetischer Kompatibilität.

Den vollständigen Text dieser Erklärung einschließlich der Definition der entsprechenden Direktiven sowie der jeweiligen Standards erhalten Sie von Ihrem Seiko Colorgrafx Systems Kundendienst oder Ihrem Seiko Engineering Systems Kundendienst.

This Perchlorate warning applies ONLY in California USA

“Perchlorate Material - special handling may apply,

See www.dtsc.ca.gov/hazardouswaste/perchlorate”

CE Marking

It is legally mandatory for products distributed or sold in the EU to bear a CE Mark that indicates compliance with requirements set forth in EC directives for the particular product. These directives set the scope of machinery subjected to the specific directive. Our LP-1020 complies with the EMC Directive (2004/108/EC) and Low Voltage Directive (2006/95/EC).

For inquiries concerning CE Marks:

Seiko Instruments Europe S.A

European Head Office

Avenue de Messidor 198, 1180, Brussels, Belgium

TEL: +32 (0) 2 346 62 74

FAX: +32 (0) 2 347 52 68

Introduction

Thank you for purchasing our LP-1020/1020L Black-and-White Raster Plotter (hereafter referred to as “this device”).

This manual explains the overall device operations, functions and operation method under the premise that installation of the device has been completed.

Before using this device, please read the “Safety Precautions” so that you may operate this device safely and correctly. Keep this manual in a place where you can quickly access it at any time.



This device employs either one of the following feeders: 1-roll paper feeder for standard sheet drawings with output up to 2.5 m, or 2-rolls paper feeder for long sheet drawings with output up to 10 m.

This manual explains how to use the 2-rolls paper feeder devices, but also accomodates the 1-roll paper feeder devices.

Safety Precautions

The following symbols are used in this manual to ensure the proper use of the plotter and to prevent the plotter from being damaged.

Please follow these guidelines:

 WARNING	Warnings must be followed carefully to avoid serious bodily injury or death.
 CAUTION	Cautions must be observed to avoid damage to your equipment and bodily injury.

Example of symbols:



This symbol () denotes items that require special care while executing a certain procedure or operation.



This symbol () denotes items that are forbidden.



This symbol () denotes items you should follow to prevent accidents or injury.

Warning



DO NOT touch any of the parts inside the plotter with a "HIGH VOLTAGE" label attached as it may result in electric shock.



DO NOT touch any of the parts inside the plotter with a "HIGH TEMPERATURE" label attached as it may result in severe burns.



DO NOT disassemble or modify the plotter. DO NOT repair the plotter by yourself. Doing so may cause fire, electric shock or other accidents.



DO NOT throw the toner cartridge or waste toner bottle into fire or place them near heat as they could explode or catch fire leading to serious accidents and/or bodily injury.



NEVER use the plotter in a place of extreme humidity or any place where it can possibly be splashed by any liquids. If any liquids get into the plotter, it could lead to fire, electric shock, or other serious accidents.



DO NOT allow metal to touch the internal parts of the plotter. Doing so may cause fire, electric shock, or other accidents.



DO NOT disconnect or connect the power cable with wet hands. Doing so may lead to electric shock.



Power OFF the plotter and unplug the power cable from the power outlet in any of the following cases:

- ◆ When putting your hands inside the plotter.
- ◆ Smoke, strange noise or smells erupt from the plotter.
- ◆ A piece of metal or any liquid touches the internal parts or slots of the plotter.
- ◆ An error requiring service from a service center occurs.

Using the plotter in any manner other than for which it was designed may cause accidents or fire.

 **Caution**



DO NOT disassemble, modify the toner cartridge. If toner gets on your skin or clothes, wash off the affected area immediately with soap and water.



Handle the toner cartridge with extreme care. Should any toner get into your eyes, do not rub them, flush them immediately with water, and see a physician immediately.



Handle the paper rolls with care because they are very heavy. Dropping them may lead to personal injury.



Use care when cutting the paper rolls with a scissors or knife during installation.



DO NOT unplug the electric cable by pulling on the cable. Doing so may cause the cable to fray or break which could lead to electric shock and/or fire.

In order to ensure the safe operation of the plotter heed all of the cautions and warnings contained throughout this manual.

Warning labels

Warning labels are affixed to this device at the locations indicated in the diagram below. You should understand the meanings of these warning labels and handling instructions.

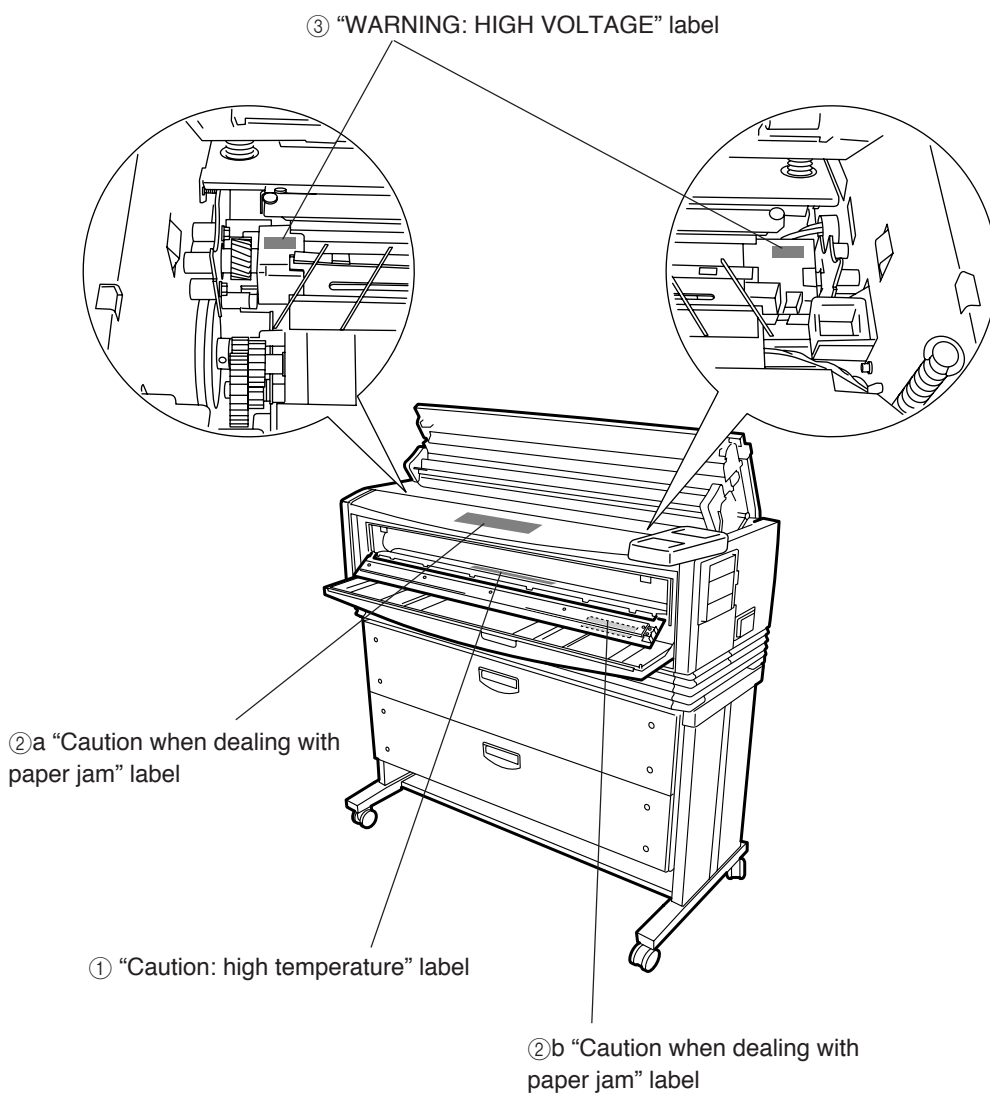

- ① “Caution: high temperature” label (It is affixed to the inside of the fixation door.)

This label cautions you not touch this area due to high temperature. The fixation device will become hot. Take care to avoid contact when dealing with paper jams.



- ② “Caution when dealing with paper jams” label

This label indicates the direction that jammed paper should be pulled out when paper is jammed in the fixation device. Follow the directions on the label to remove the paper.

a

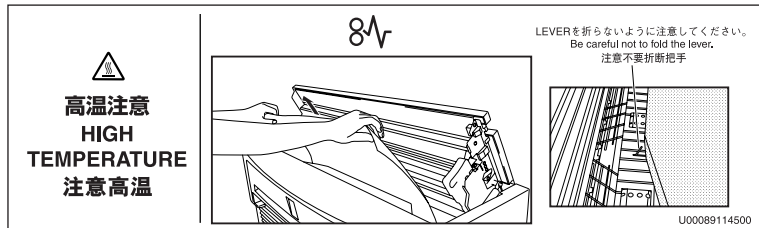

b

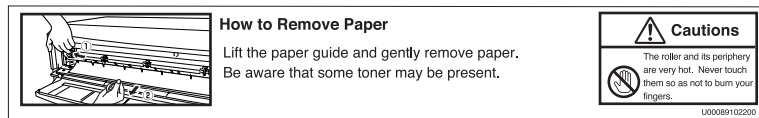

- ③ “WARNING: HIGH VOLTAGE” label

This label cautions against contact due to high voltage application. As it is dangerous, never contact this area.



How to read this manual

Manual make-up

This manual is composed of 13 chapters and an appendix.

Chapter 1 provides information that you should know before using this device, such as device features and part names. First read chapter 1 for an understanding of basic matters pertaining to this device.

Chapter 2 provides information on matters you will need to know to operate this device, such as turning the power on and off, and how to put paper in the device. Refer to this chapter for basic information on operating this device.

Chapters 3 to 13 provide information on device functions, operation and how to manage the settings. First read chapters 3 and 4 for an overview of functions and operations. Then proceed to the chapter you want to refer to.

- Chapter 5: Refer to this chapter when setting the data format you will use.
- Chapter 6: Refer to this chapter when setting the operating conditions for the engine of this device.
- Chapter 7: Refer to this chapter when you have loaded a different type of paper in the device and you must change the settings accordingly.
- Chapter 8: Refer to this chapter to confirm Setup contents or to set the date and time.
- Chapter 9: Refer to this chapter when setting the communication protocol.
- Chapter 10: Refer to this chapter when conducting initialization.
- Chapter 11, 12: Refer to these chapters when setting the communication conditions for Ethernet and parallel connection or when returning to the default settings.
- Chapter 13: Refer to this chapter when using "Teiplot".

Chapter 14 provides information on troubleshooting if a problem occurs with this device. Appropriate countermeasures should be conducted in accordance with the explanations in this chapter.

The basic specifications and command list for this device can be found in the appendix. The menu structure is explained in great detail here. Refer to this menu to perform settings for menus which are not fully explained by the setting operations for chapters 5 to 13.

Notation method

Markings

Warning

- ◆ This mark indicates warnings that must be followed carefully to avoid serious bodily injury or death.

Caution

- ◆ This mark indicates cautions that must be observed to avoid damage to the equipment and bodily injury.

Note

- ◆ Contain important information.



This is a “Tip” mark.

Contain additional hints for better use.



This is a “See” mark.

A reference section and page is indicated after this mark.

DSCAN format



Please remember:

The DSCAN format described in this manual as well as DSCAN that appears on the operation display are for only customers in Japan.

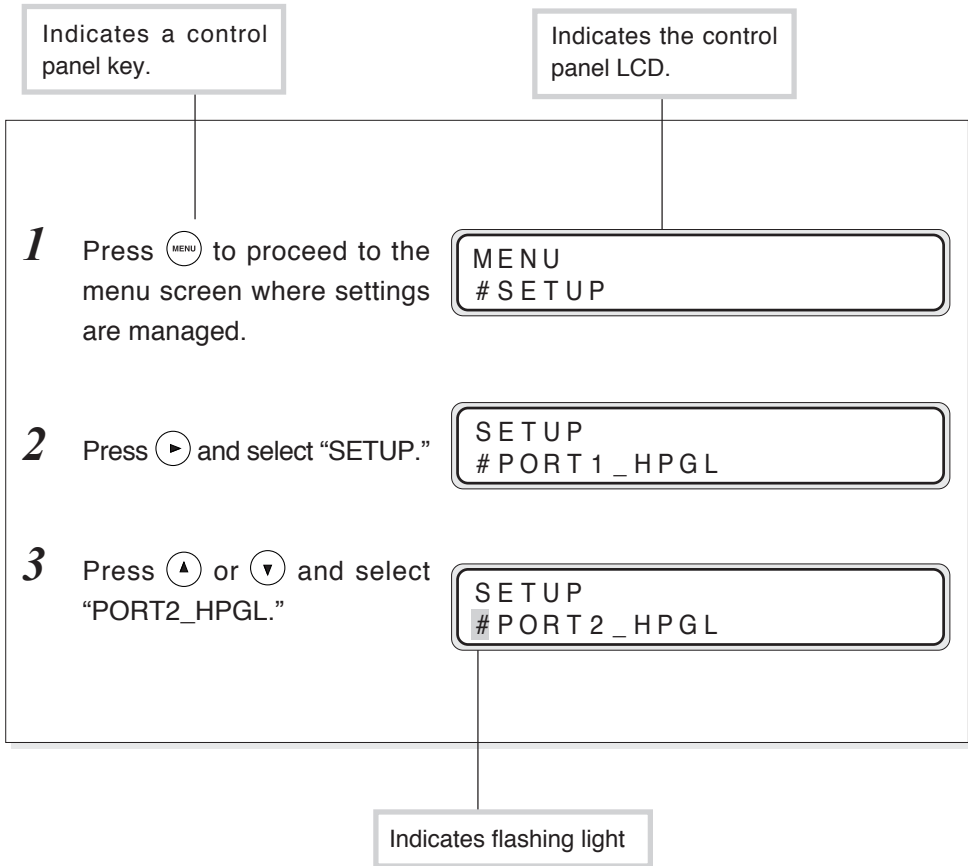
Key/LCD/LED notations



LED on, flashing, and off states are indicated as follows:

-  On
-  Flashing
-  Off

Supplied components

Components and options listed below are included.

If any components are missing or broken, contact your retailer or your nearest service center.

Item	Quantity	Remarks
Plotter unit	1 unit	
Toner cartridge	3 units	For checking at the time of installation
Waste bottle	1 unit	Pre-installed
Quick Reference Guide	1 or 2 copies	200V: English and Chinese
CD-ROM	1 set	
Paper flange	2 units/drawer	
Process cartridge	1 unit	With 2 ozone filters
Roll paper	1 box	A0, A1, A3 x 1 unit each, for checking at the time of installation
Scanner exit guide	3 pieces	MF model only
Panel sheet	2 sheets	200V only: English and Chinese
Power cable	2 units	200V only: 2 types

Options

Item	Quantity	Remarks
LP-817 (bucket)	1 unit	
LP-819 (carrier sheet set)	1 unit	MF model only
LP-840 (color upgrade kit-S)	1 unit	MF-S model (North/South America and Europe)
LP-841 (color upgrade kit-L)	1 unit	MF-L model (North/South America and Europe)
LP-842 (color upgrade kit-S)	1 unit	MF-S model (Asia and Oceania)
LP-843 (color upgrade kit-L)	1 unit	MF-L model (Asia and Oceania)

TABLE OF CONTENTS

Introduction	i
Safety Precautions	ii
Warning labels	v
How to read this manual	vii
Manual make-up	vii
Notation method	viii
Markings	viii
DSCAN format	viii
Key/LCD/LED notations	ix
Supplied components	x

Chapter 1 Getting started 1-1

Features	1-2
Operating conditions	1-4
Environmental conditions	1-4
Installation space	1-6
Usable paper	1-7
Spool memory configuration	1-10
The names and functions of each part	1-11
Front	1-11
Right side/rear side	1-12
Interior	1-13
Control panel	1-14
How to read the status displays for this device	1-17

Chapter 2 Basic operations 2-1

Plotting procedures overview	2-3
Turning the power on and off	2-3
Power on	2-4
Power off	2-6
Installation operations	2-7
Online and offline	2-10
Online	2-10
Offline	2-10
Replacing paper rolls	2-11
Precautions during replacement	2-13
How to detach the paper rolls	2-14
How to attach the paper roll	2-16
Replacing the toner	2-19
Precautions on handling	2-20
Toner replacement procedures	2-21
Replacing the waste toner bottle	2-24
Precautions during replacement	2-24
Waste toner bottle replacement procedures	2-25
Replacing the process cartridge	2-28
Precautions during replacement	2-28
Process cartridge replacement procedures	2-29

Manual paper feeding (cut paper)	2-34
Manual feeding procedures	2-34
Manual paper feeding procedure	2-35
Pause, continue, cancel (and additional printing)	2-39
Print stop	2-39
Continue printing	2-39
Cancel printing	2-40
Additional printing	2-40
Web function	2-41
Functions	2-41
Web function startup method	2-42
Cleaning the exterior	2-43
Using paper of new standard series	2-44
Using paper of Chinese standard series	2-46
Limiting rolls to be used	2-48

Chapter 3 Menu overview 3-1

Channels and ports	3-3
Data formats	3-3
Data formats which can be used	3-3
Data format auto-judging	3-3

Jobs	3-4
Reprinting	3-4
Settings menu	3-5
PDL menu	3-8
When using our company's printer driver	3-8
Items which you can set	3-9
Idle status	3-9
Printing status	3-11
Menu screen	3-11
Setup menu "SETUP"	3-11
Device menu "DEVICE"	3-12
Paper menu "PAPER"	3-13
Function menu "FUNCTION"	3-14
Protocol menu "PROTOCOL"	3-15
Reset menu "RESET"	3-16
System menu "SYSTEM"	3-17

Chapter 4 Basic Menu Operation 4-1

Summary of basic menu operation	4-2
Offline menu operation	4-3
Switching the menu on the same hierarchy	4-3
Moving the menu hierarchy	4-4
Setting or changing the parameters	4-5
Exiting the setting	4-10

Chapter 5 "SETUP" Menu

5-1

Setting parameter items	5-2
Setup menu setting parameter table	5-3
Setup parameter priority mode	5-10
PARAMETER MODE (DSCAN only)	5-11
MEDIA SERIES (HP-GL, TIFF, CALS only)	5-11
AUTO SUPPLY	5-12
FIXING MODE	5-13
COPY COUNT	5-14
SUPPLY PARAM.	5-15
DRAWING PARAM.	5-17
SCALING PARAM.	5-21
FORMAT PARAM. (HP-GL DSCAN only)	5-24
PEN PARAMETER (HP-GL DSCAN only)	5-29
RASTER PARAM	5-34

Chapter 6 "DEVICE" menu

6-1

Setting items	6-2
POWER SAVE	6-3
EDGE CUT TIMER	6-4
DOOR OPEN CUT	6-5
DENSITY	6-5
TRACING PAP. MODE	6-5
BOTTLE MODE	6-6

Chapter 7 "PAPER" menu 7-1

- Setting items 7-2
 - MEDIA TYPE 7-2
 - MEDIA SERIES 7-3

Chapter 8 "FUNCTION" menu 8-1

- Setting items 8-2
 - MENU PRINT 8-3
 - HPGL SELF PLOT 8-5
 - DSCAN SELF PLOT 8-6
 - ERROR LOG 8-7
 - JOB LOG 8-8
 - ENGINE LOG 8-10
 - SYSTEM DATE 8-11
 - SYSTEM TIME 8-11
 - INIT CHARG. INF 8-11
 - PRINT CHARG. INF 8-11
 - MAINTE INFO 8-12
 - DATA DUMP 8-12

Chapter 9 "PROTOCOL" menu 9-1

- Setting items 9-2
 - PDL SELECT 9-3
 - XPT PORT 9-4
 - PRINTER NAME 9-4
 - USER NAME 9-5

Chapter 10 "RESET" menu 10-1

Reset functions	10-2
SYSTEM RESET	10-2
PORT RESET	10-3

Chapter 11 "SYSTEM" menu 11-1

Setting items	11-2
Communication parameter "COMM. PARAM"	11-3
WEB LOCK	11-5
ENABLE SERIES	11-6
APPLY ROLL	11-8
CHINA SIZE	11-10
INITIAL SET	11-11
LANGUAGE	11-12
LENGTH UNITS	11-12
ADMIN PASSWORD	11-12

Chapter 12 Ethernet parameter "ETHERNET" 12-1

Setting items	12-2
PORT SELECT	12-4
DHCP	12-4
IP ADDRESS	12-5
SUBNET MASK	12-5
ROUTING TABLE	12-6
SETUP DETAILS	12-7

Chapter 13 Terioplots **13-1**

- About Terioplots 13-2
- Terioplots Hardware Requirements 13-3
- Settings 13-4
- Restrictions 13-5

Chapter 14 Troubleshooting **14-1**

- Troubleshooting 14-2
- When an error message appears 14-3
 - Paper Jam 14-3
 - Door Open 14-14
 - Operator Call 14-16
 - Warning 14-17
 - Service Call Errors 14-25
- Error log 14-29
 - Classification of Error/Warning 14-29
 - Format of Message 14-29
 - Log Registration Format 14-30
 - Type of Error Log 14-31
 - Error Log Classification Table 14-33
- Troubleshooting for ethernet 14-34
- If "BOTTLE MAINT. STARTS" appears 14-36

When a print error occurs 14-37

When there is an abnormal sound 14-38

Appendix

Appendix-1

Basic specifications Appendix-2

 Plotter Specification Appendix-2

Menu structure Appendix-4

 [SETUP] MENU Appendix-4

 [DEVICE] MENU Appendix-10

 [PAPER] MENU Appendix-11

 [FUNCTION] MENU Appendix-12

 [PROTOCOL] MENU Appendix-13

 [RESET] MENU Appendix-14

 [SYSTEM] MENU Appendix-15

Command list Appendix-21

 HP-GL,HP-GL/2 Device Control Command List ... Appendix-21

 HP-GL,HP-GL/2 Device Plotting Command List .. Appendix-22

 HP RTL Plotting Command List Appendix-25

 D-SCAN Format Command List Appendix-27

 TIFF Tag Appendix-33

 CALS Format Records Appendix-34

 ftp Tag Appendix-34

 lpd Support Commands Appendix-36

 xpt(socket I/F) Appendix-36



Chapter 1

Getting started

Chapter 1 provides necessary information to operate this device. Read this chapter to understand the basics of this device before proceeding to the following chapters.

Contents of this chapter

Features

Operating conditions

The names and functions of each part

How to read the status displays for this device

Features

This device is an electrophotographic black-and-white raster plotter which produces plots by receiving graphic data created by a work station or PC (hereafter referred to as a computer.)

This device is equipped with the following features:

High speed plotting output, high resolution

This device has 80 mm (3.15 inches)/sec recording speed and can output A0 size drawings at 3.4 sheets per minute. It can also output high accuracy drawings at 600 dpi resolution.

2-roll paper feeding mechanism, long drawing compatible

This device employs a 2-roll paper feeding mechanism that sets 2 sizes from a choice of 4 sizes: A0 size (or 36 inch size), A1 (or 24 inch size), A2 (or 18 inch size), and A3 (or 12 inch size). By employing paper rolls compatible with drawing sizes ranging from A0 to A4, a low running cost is achieved by reducing paper consumption.

This device can also output 2.5 m / 98.4 inch size (10 m / 393.7 inch for the LP-1020L) long sheet drawings. The maximum plotting range of this device is as follows:

(Note)

Picture quality and printing accuracy can only be assured for plain paper and recycled paper. (Only up to twice the length of the standard-size paper can be assured for tracing paper and film.)

LP-1020

- A0 size paper roll : 841 × 2500 mm (33.1 × 98.4 inches)
- A1 size paper roll : 594 × 1830 mm (23.4 × 72 inches)
- A2 size paper roll : 420 × 1200 mm (16.5 × 47.2 inches)
- A3 size paper roll : 297 × 920 mm (11.7 × 36.2 inches)

LP-1020L

- A0 size paper roll : 841 × 10,000 mm (33.1 × 393.7 inches)
- A1 size paper roll : 594 × 10,000 mm (23.4 × 393.7 inches)
- A2 size paper roll : 420 × 1220 mm (16.5 × 47.2 inches)
- A3 size paper roll : 297 × 920 mm (11.7 × 36.2 inches)

Manual feeding mechanism	<p>This device is equipped with a manual feeding print function.</p> <p>(Note) The picture quality and printing accuracy for manually fed printing cannot be assured.</p>
Multiport interface	<p>The device is equipped with an Ethernet interface and allows for network connection to network. It can also be equipped with both parallel interface and USB interface. In addition, 10 logical ports can be used for the Ethernet interface, which then allows up to 12 computers, including parallel interface and USB interface, to be simultaneously connected.</p>
Supports a variety of paper types	<p>4 types of rolls—paper, recycled paper, tracing paper, and film—are supported.</p>
Front paper feeding/ finished drawing outlet	<p>The device has a front paper feeding and finished drawing outlet structure. This allows for paper to be loaded and output drawings to be processed only at the front of the device. This means that the device requires only a small installation space.</p> <p>The device was designed for simple, front operation, allowing paper to be loaded and toner cartridges to be replaced with ease.</p>

Operating conditions

This section covers operating conditions of this device including environmental conditions, installation space, supported papers and spool memory configuration.

Environmental conditions

This device should be used within the temperature and humidity ranges indicated in the graph below.



Tips

- ◆ To obtain the best picture quality, use the device within a temperature and humidity range of 20 to 30°C, 45 to 60%RH. (relative humidity)

■ Operating temperature and humidity range

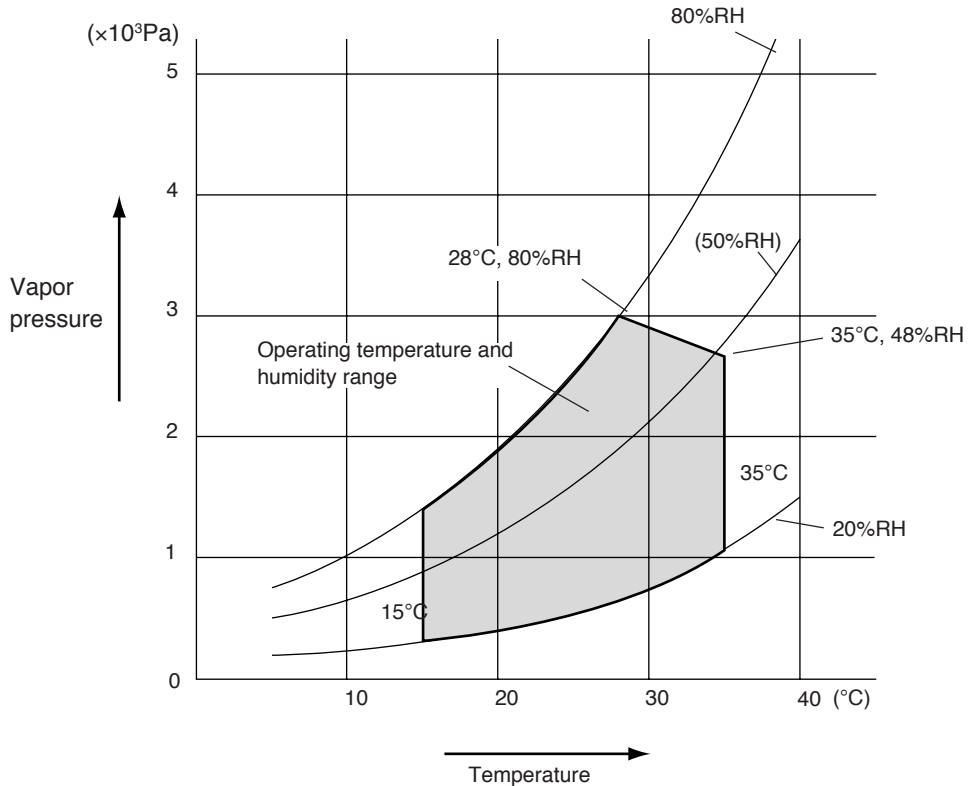

Do not install the plotter in the following places:

- ◆ Places exposed to direct sunlight
- ◆ Places subject to vibration
- ◆ Places with excessive dust
- ◆ Places subject to extreme changes in temperature or humidity
- ◆ Places near an air conditioner or a heater
- ◆ Places where the plotter may get wet
- ◆ Places subject to direct air flow from a vent
- ◆ Places near a diazo copier that may generate ammonia gas
- ◆ Places with poor ventilation

Installation space

When installing this device, space to the front, rear, left and right sides of the device should be accommodated for the replacement of consumables, the processing of output drawings, and the ventilation. The minimum installation space indicated in the diagram below should be ensured. The maintenance space indicated in the diagram below is needed to perform parts replacement, etc.

■ Installation/maintenance space

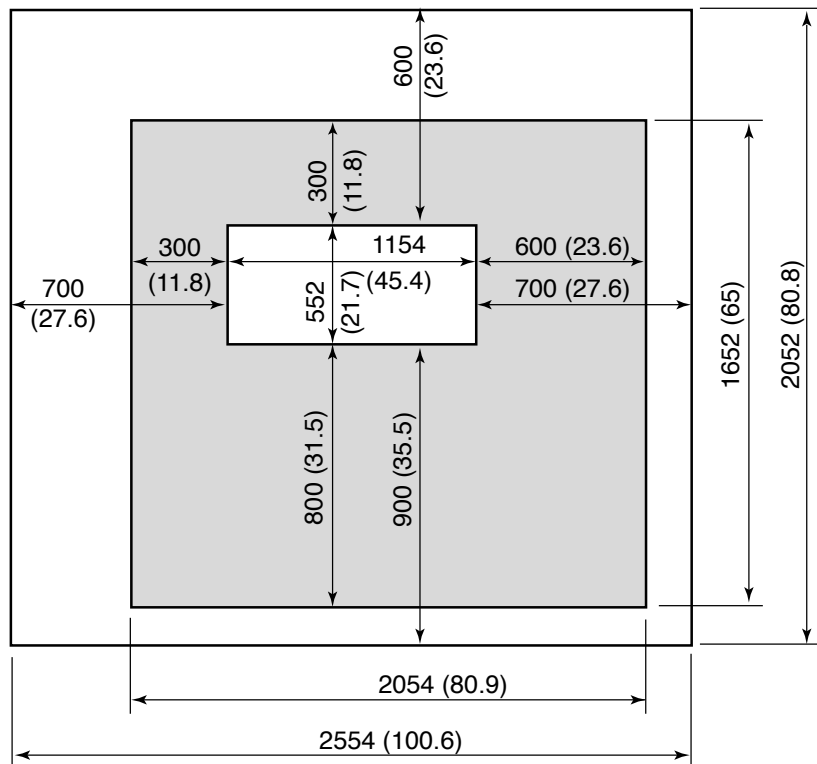

(Height is 2000 mm / 78.7 inches)

- Installation space
 - Maintenance space
- units: mm (inch)

Note

◆ When moving this device from its current location to a different location, contact our company's service center.

Supported

Use roll paper specified by our company as indicated below:

Note

◆ If paper not specified by our company is used, picture quality cannot be assured. Moreover, the device may malfunction.

■ Roll paper specified by our company

Part No.	Paper type & size	
LP-733	Plain paper (67g / m ²)	A0 size width (841 mm / 33.1 inches)
LP-780		A1 size width (594 mm / 23.4 inches)
LP-788		A2 size width (420 mm / 16.5 inches)
LP-781		A3 size width (297 mm / 11.7 inches)
LP-735	Tracing paper (75g / m ²)	A0 size width (841 mm / 33.1 inches)
LP-782		A1 size width (594 mm / 23.4 inches)
LP-740		A2 size width (420 mm / 16.5 inches)
LP-783		A3 size width (297 mm / 11.7 inches)
LP-744	Mat film (#300)	A0 size width (841 mm / 33.1 inches)
LP-786		A1 size width (594 mm / 23.4 inches)
LP-743		A2 size width (420 mm / 16.5 inches)
LP-787		A3 size width (297 mm / 11.7 inches)
LP-734	Recycled paper (66g / m ²)	A0 size width (841 mm / 33.1 inches)
LP-947		A1 size width (594 mm / 23.4 inches)
LP-948		A2 size width (420 mm / 16.5 inches)
LP-949		A3 size width (297 mm / 11.7 inches)

The following roll paper of the widths can be also used.

■9×12 inch series

Roll width	Name of fixed form	Lengthwise	Widthwise
36 inches (914.4 mm)	E-form size	1219.2 mm (48 inches)	914.4 mm (36 inches)
	D-form size	914.4 mm (36 inches)	609.6 mm (24 inches)
24 inches (609.6 mm)	D-form size	914.4 mm (36 inches)	609.6 mm (24 inches)
	C-form size	609.6 mm (24 inches)	457.2 mm (18 inches)
18 inches (457.2 mm)	C-form size	609.6 mm (24 inches)	457.2 mm (18 inches)
	B-form size	457.2 mm (18 inches)	304.8 mm (12 inches)
12 inches (304.8 mm)	B-form size	457.2 mm (18 inches)	304.8 mm (12 inches)
	A-form size	304.8 mm (12 inches)	228.6 mm (9 inches)

■8.5×11 inch series

Roll width	Name of fixed form	Lengthwise	Widthwise
34 inches (863.6 mm)	E-form size	1117.6 mm (44 inches)	863.6 mm (34 inches)
	D-form size	863.6 mm (34 inches)	558.8 mm (22 inches)
22 inches (558.8 mm)	D-form size	863.6 mm (34 inches)	558.8 mm (22 inches)
	C-form size	558.8 mm (22 inches)	431.8 mm (17 inches)
17 inches (431.8 mm)	C-form size	558.8 mm (22 inches)	431.8 mm (17 inches)
	B-form size	431.8 mm (17 inches)	279.4 mm (11 inches)
11 inches (279.4 mm)	B-form size	431.8 mm (17 inches)	279.4 mm (11 inches)
	A-form size	279.4 mm (11 inches)	215.9 mm (8.5 inches)

■30×42 inch series

Roll width	Name of fixed form	Lengthwise	Widthwise
30 inches (762.0 mm)	30×42 size form size	1066.8 mm (42 inches)	762.0 mm (30 inches)

■Map series

Roll width	Name of fixed form	Lengthwise	Widthwise
700.0 mm (27.6 inches)	B1 form size	1000.0 mm (39.4 inches)	700.0 mm (27.6 inches)
	B2 form size	700.0 mm (27.6 inches)	500.0 mm (19.7 inches)
500.0 mm (19.7 inches)	B2 form size	700.0 mm (27.6 inches)	500.0 mm (19.7 inches)

■DIN series

Roll width	Name of fixed form	Lengthwise	Widthwise
707.0 mm (27.8 inches)	B1 form size	1000.0 mm (39.4 inches)	707.0 mm (27.8 inches)
	B2 form size	707.0 mm (27.8 inches)	500.0 mm (19.7 inches)
500.0 mm (19.7 inches)	B2 form size	707.0 mm (27.8 inches)	500.0 mm (19.7 inches)
	B3 form size	500.0 mm (19.7 inches)	353.0 mm (13.9 inches)

■China series

The China series roll cannot be used for plotting with cut sheet feeding. It can be used for real size plotting only.

Chinese series A0 roll width	Chinese series A1 roll width	Chinese series A2 roll width	Chinese series A3 roll width
914 mm (36 inches)	620 mm (24.4 inches)	450 mm (17.7 inches)	310 mm (12.2 inches)
910 mm (35.8 inches)	610 mm (24 inches)	440 mm (17.3 inches)	297 mm (11.7 inches)
900 mm (35.4 inches)	-	-	-
880 mm (34.6 inches)	-	-	-

Paper storing precautions are as follows:

Notes

- ◆ Store the paper in a cool dark place with in the specified humidity ranges.
- ◆ Store the paper in it's packaging material so that dust will not accumulate on the paper.

Spool memory configuration

Spool memory configurations are available for this device as specified below.

Expansion kit
LP-815

Extends spool memory.
Spool memory is the memory needed to receive plotting data.
If plots cannot be produced normally due to spool memory shortage, installing the following options allows plots to be produced normally.

■ Spool memory configuration when LP-815 is installed

Device configuration	Device configuration	Spool memory
LP-1020	During standard configuration	12MB
	When LP-815 is installed	2GB
LP-1020L	Standard configuration	2GB

Note

- ◆ The maximum capacity to be actually spooled is slightly different from the values indicated in the above table. Confirm the capacity by executing "MENU PRINT."

The names and functions of each part

This section explains the names, usage information, and functions of each part of this device.

Front

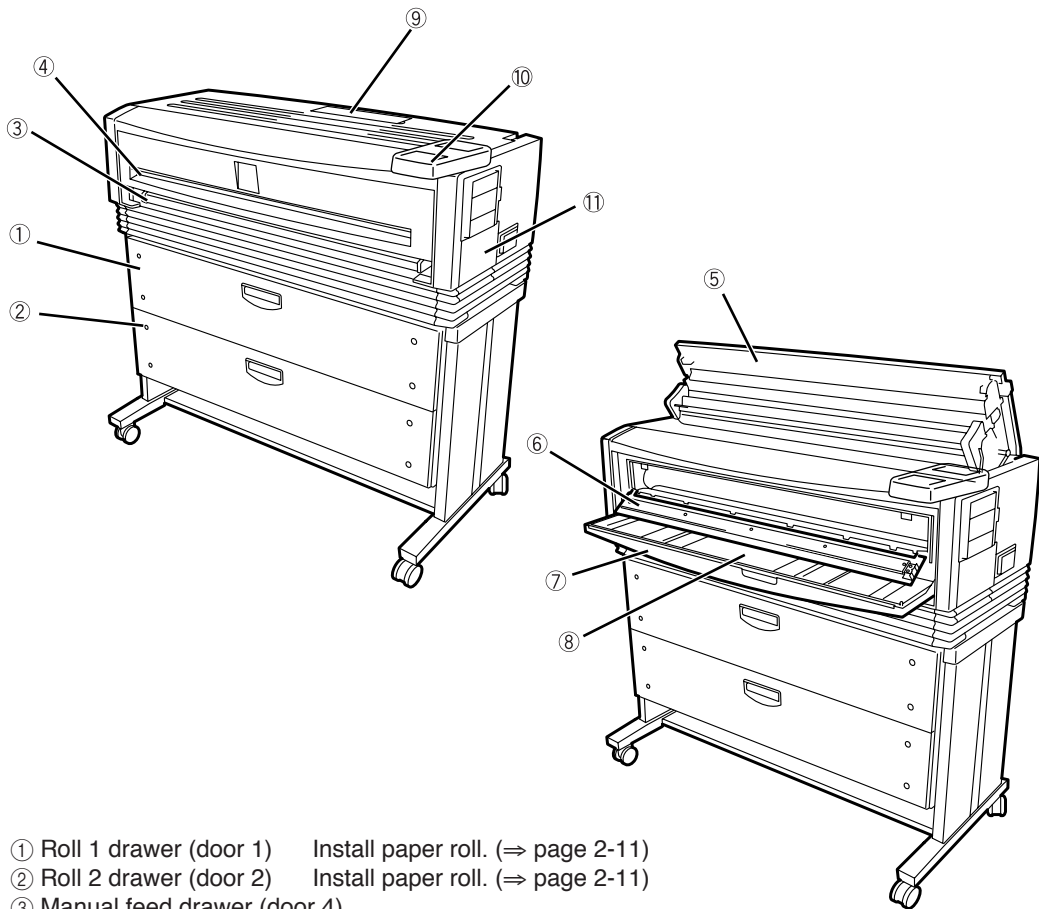

- ① Roll 1 drawer (door 1) Install paper roll. (⇒ page 2-11)
- ② Roll 2 drawer (door 2) Install paper roll. (⇒ page 2-11)
- ③ Manual feed drawer (door 4) Open this drawer when a paper jam occurs during manual feeding. (⇒ page 14-3)
- ④ Finished drawing outlet Drawings exit from here.
- ⑤ Top cover (door 6) Open this cover when a paper jam occurs near the top door. (⇒ page 14-3)
- ⑥ Fixation door (door 7) Open this door when a paper jam occurs in the vicinity of the finished drawing outlet. (⇒ page 14-3)
- ⑦ Manual paper feeding guide (door 8) Open this door when feeding the paper manually. (⇒ page 2-34)
- ⑧ Manual feed inlet Insert paper from this inlet during manual feeding. (⇒ page 2-34)
- ⑨ Toner cover Open this cover when replacing toner. (⇒ page 2-19)
- ⑩ Control panel The LEDs and LCD which indicate device status and the keys to set various functions are laid out here. (⇒ page 1-14)
- ⑪ Waste toner door Open this door to replace a waste toner bottle. (⇒ page 2-24)

Right side/rear side

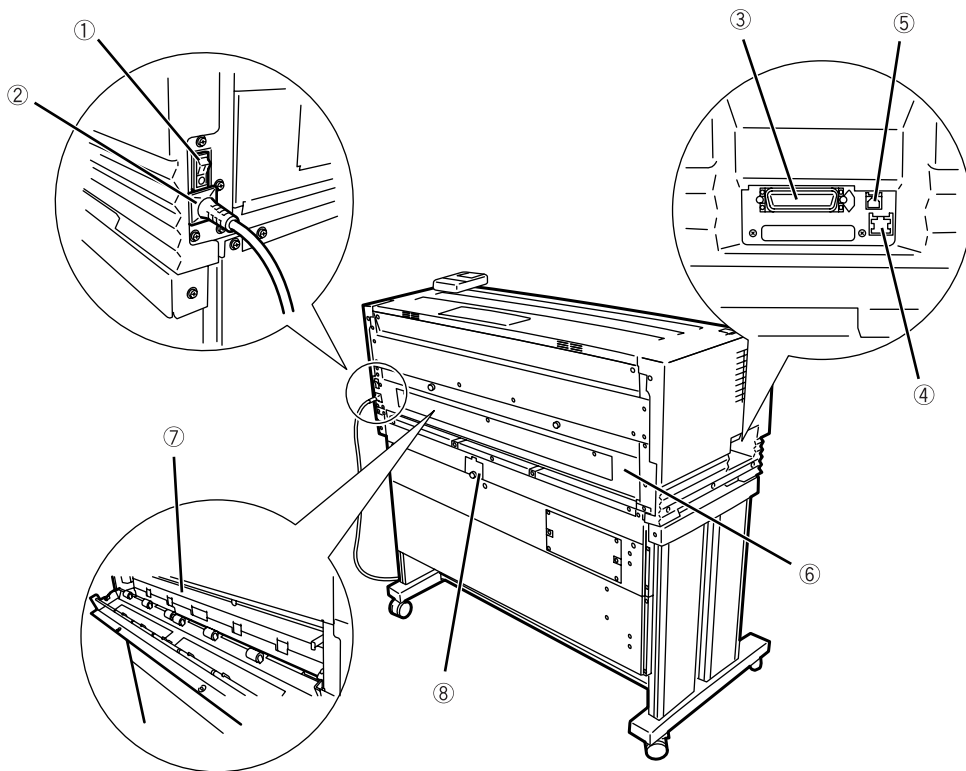

- ① Main power switch Turns the device power on and off. (⇒ page 2-3)
- ② Power cord Plug this cord into a power cord socket.
- ③ Parallel interface connector
This is an interface connector conforming to the standards of the Parallel interface connector of Centronix.
- ④ Ethernet interface connector
This is an interface connector for a 100 BASE-TX and 10 BASE-T Ethernet interface connector.
- ⑤ USB interface connector This is an interface connector for a USB 2.0 interface connector.
- ⑥ Cutter door (door 5) Open this door to deal with paper jams at the cutter area.
(⇒ page 14-3)
- ⑦ Cutter door inside (door 9)
Open this door to deal with paper jams at the cutter area.
(⇒ page 14-3)
- ⑧ Cutter door lower small door (door 10)
Open this door to deal with paper jams at the cutter area.

Interior

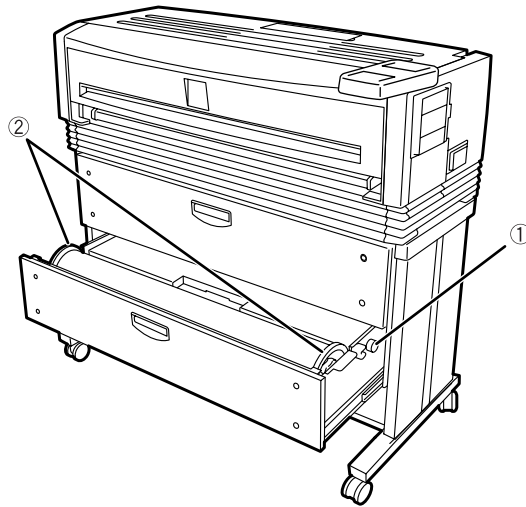

- ① Paper feed knob Feeds the end of the roll to the paper feed inlet. (⇒ page 2-11)
- ② Paper flange This flange is attached to the roll paper. (⇒ page 2-11)

Control panel

The keys, LEDs and LCD are laid out on the control panel as illustrated in the following diagram.

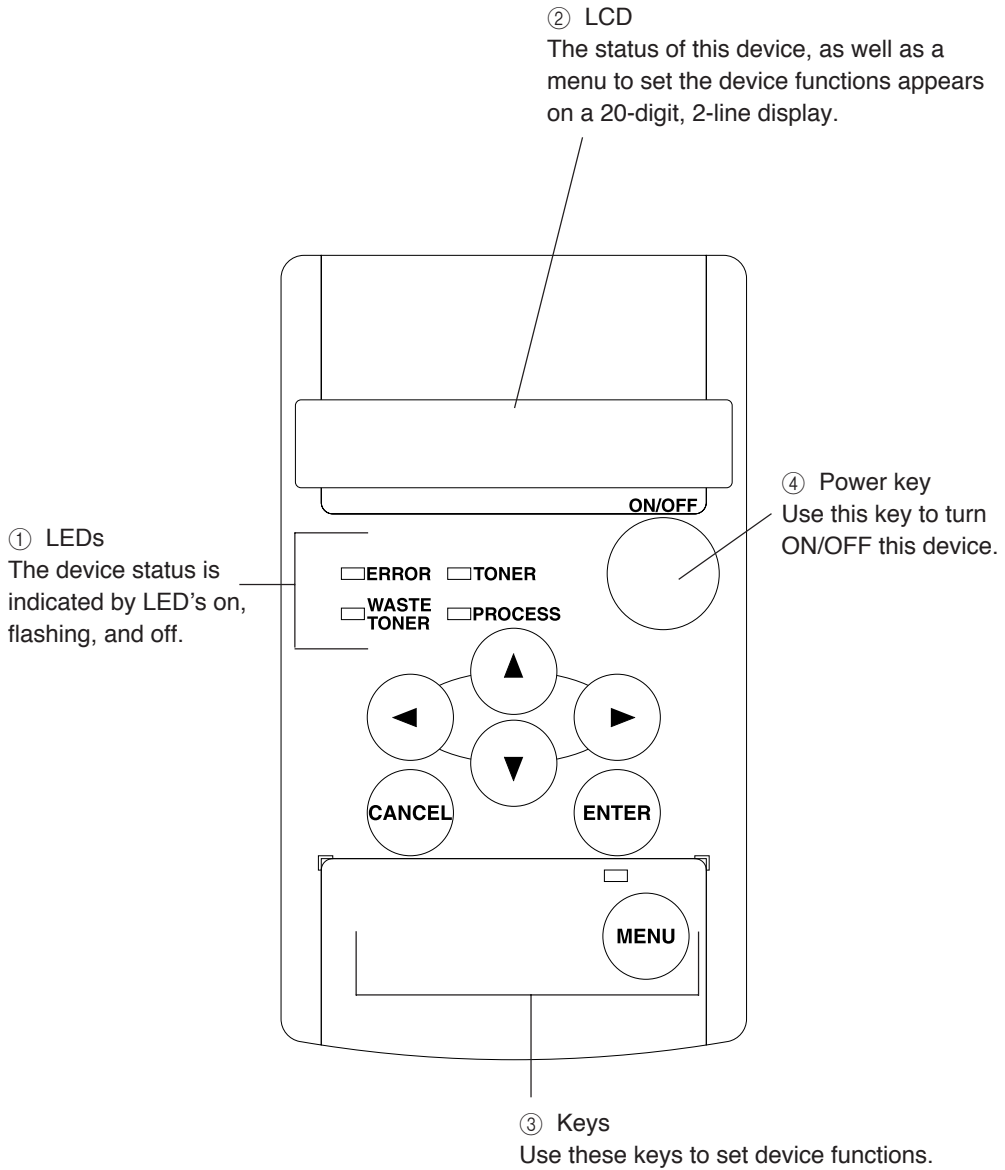

LCD, LEDs, and key functions

Number	Name	Function
① LED's	Error lamp (red)	Indicates the presence or absence of errors. On: Error present Off: No error present
	Toner lamp (green)	Indicates the amount of remaining toner. On: There is sufficient toner. Flashing: Toner is running low. Off: There is no toner (plots cannot be produced without replenishment.)
	Waste toner lamp (green)	Indicates the toner waste bottle replacement time. On: Normal Flashing: Replacement timing is approaching Off: Plots cannot be produced without replacement
	Process lamp (green)	Indicates the process cartridge replacement time. On: Normal Flashing: Replacement time is approaching Off: Process cartridge is not installed.
	Menu lamp (green)	Indicates that this device is ready for setting, receiving data, or printing. On: Setting operations can be performed Off: Ready to receive data and print.
② Display	LCD	Displays a variety of messages in a 20-figure and 2-line display to inform you of the device status.
③ Keys	MENU key	Switches the status of the device from setting ready status to data receive and print ready status.
	ENTER key	Inputs the parameters.
	CANCEL key	Cancels parameter input.
	▲ Key	Switches menu items and changes parameters.
	▼ Key	Switches menu items and changes parameters.
	◀ Key	Switches menu items/hierarchy and changes.
	▶ Key	Switches menu items/hierarchy and changes.
④ Power	Power key	Turns the device power on and off.

How to read the status displays for this device

This section explains the control panel LEDs and LCD which inform you of the status of the device.

The following are the main displays.

Data standby display

Standard configuration



- Error lamp
- Menu lamp

This is a print ready status.

Data processing display

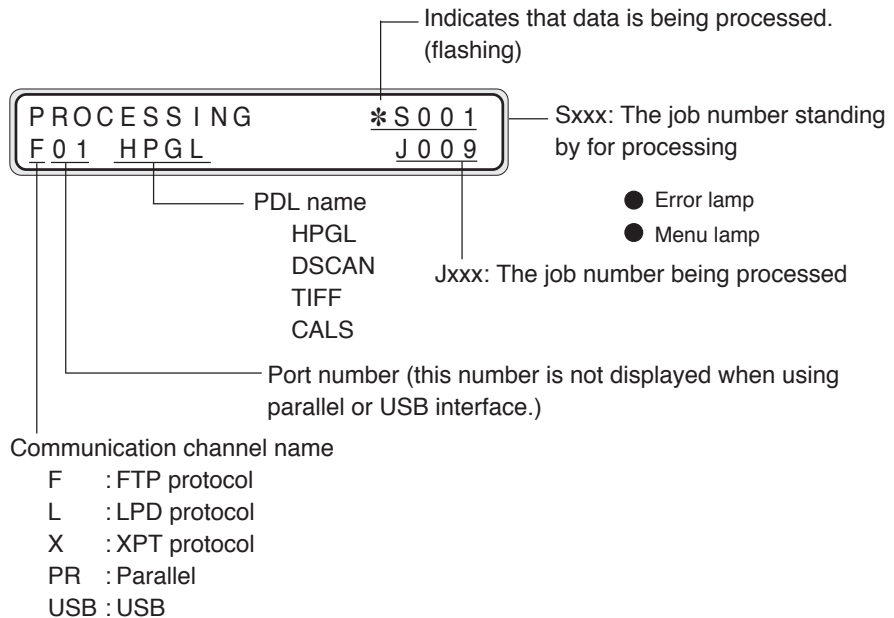

Data is being processed.

The various information for the data currently being processed is displayed.

Note

- ◆ Parallel and USB are only displayed when each interface is installed.

Printing in progress display

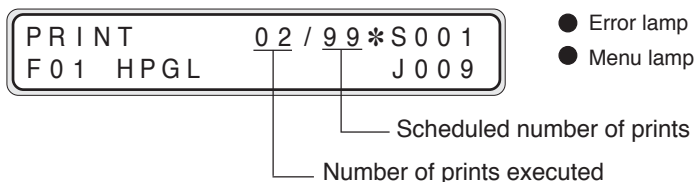

Data is being printed.
The various information for the data currently being printed is displayed.

Print information display

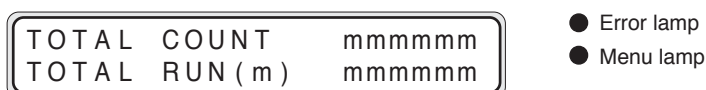

This display appears when  is pressed in data standby or print ready status.
The total number of prints and the length of media printed appear.



- ◆ Many of our customers who have signed a maintenance agreement regularly telephone our service center for assistance. When contacting our service center, please make a note of this information for your reference.
- ◆ This display appears for approximately three seconds, after which the display will automatically return to the original data standby display condition.

Setting ready display

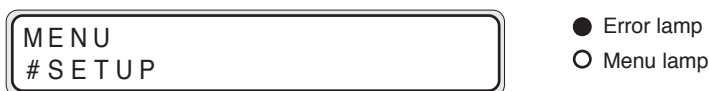

The functions for this device can be set. ⇒ chapter 3

Error display



An error has occurred.
Errors are classified according to those which can be dealt with by the operator, or errors which can only be dealt with by your dealer or our service center, etc. ⇒ Chapter 14

Warming up display

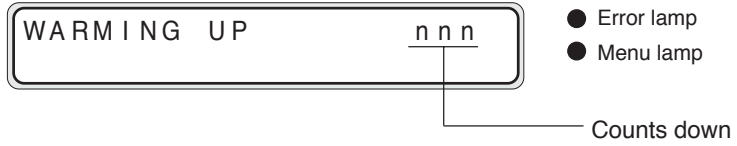

Displays the warming-up status and the time remaining until the device is ready.

Power saving display



This display appears when the device enters the power saving mode after the data standby status has continued for a certain period of time.

Chapter 2

Basic operations

Chapter 2 describes basic operating procedures for this device such as turning the power on and off, replacing paper, and replacing toner will be explained.

Contents of this chapter

Plotting procedures overview

Turning the power on and off

Installation operations

Online and offline

Replacing paper rolls

Replacing the toner

Replacing the waste toner bottle

Replacing the process cartridge

Manual paper feeding (cut paper)

Pause, continue, cancel, and additional printing

Web function

Cleaning the exterior

Using paper of new standard series

Using paper of Chinese standard series

Limiting rolls to be used

Plotting procedures overview

Plotting is usually conducted in accordance with the following procedures.

For information on computer operations, refer to your computer manual.

1 Turn on the power for the computer and this device.

For information on turning on the device power, refer to “Turning the power on/off” (⇒ page 2-3)

2 Confirm the status of the device on the control panel.

Confirm that the LEDs are not indicating abnormalities and that the LCD indicates Data standby status.

Press  when the Menu lamp is on.

When the Toner lamp is flashing or off, replace the toner. (⇒ page 2-19)

When the Toner waste bottle lamp is flashing or off, replace the waste bottle. (⇒ page 2-24)

When the Process lamp is flashing or on, replace the process cartridge. (⇒ page 2-28)

When the Error lamp is on, refer to chapter 14 for information on troubleshooting.

3 Open your application software on your computer and create a drawing.

If the device settings do not conform to the application software you are using, reset the settings for this device (⇒ Chapters 5 to 12).

4 Send the data from the computer to this device.

Turning the power on and off

This device has two power switches: the main power switch located at the lower-left as seen from the rear of the device; and the power key on the control panel.

The device power is turned on by first turning on the main power switch, and then pressing the device's control panel power key.

Notes

- ◆ While data is being processed, do not turn off the main power switch. Doing so may damage the system.
- ◆ When the power is on and the Main power switch is turned off, or when the power goes out due to blackout etc., restoring the power (turning the Main power switch back on or resetting from a blackout) is the first step, but will not turn the plotter on. You must also turn ON the power key on the control panel.

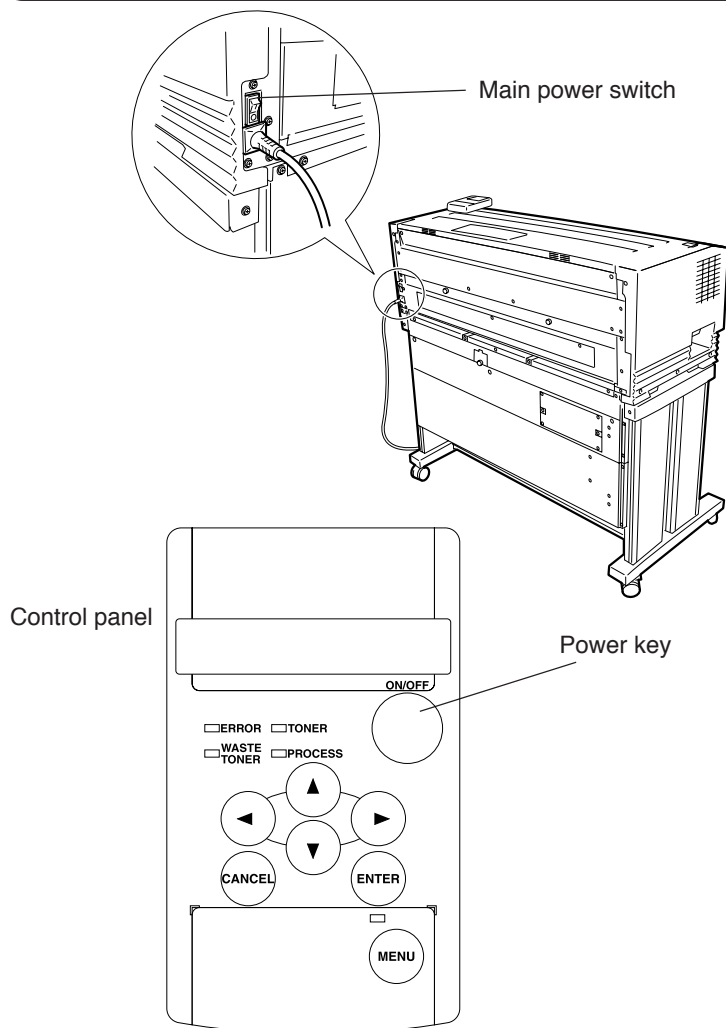

Power on

- 1** Turn on the Main power switch located at the lower-left as seen from the rear of the device.

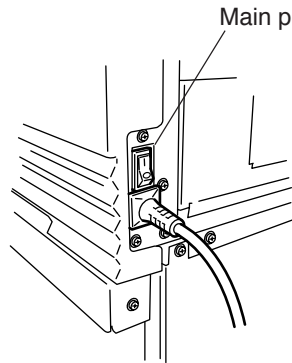

Press the power switch toward the | symbol (upwards).

- 2** Press the power key located on the control panel of this device (when the main power switch is on).



INITIALIZING
WAIT A MOMENT

When you first turn on the power after purchasing this device, a guidance display prompts you to set the panel's display language. If this setting has already been completed, this message is omitted.

LANGUAGE ?
*ENGLISH

When a job is saved, the following message appears and the device stands by for selection.

When a job is not saved, this message is omitted.

DELETE JOB?
Y=ENTER N=CANCEL

If a key input is not made, this message will time-out after about 10 seconds and the device starts up with the job in saved condition.



Under normal conditions, the display reads “INITIALIZING STANDBY” and is changed to the following message.

SYSTEM VERSION
01A



The message is changed to the “WARMING UP”.

WARMING UP n n n

Warm up will take about 4 minutes. (about 8 minutes with LP-1020L)
nnn: a count down for the warm up is displayed.



The message indicates that the device is now online (“PRINT READY”).

PRINT READY

A “PRINT READY” message indicates that the device is functioning normally.

Power off

When turning the power off, confirm that the device is in the data receive standby mode.

- 1** Press the Power key on the device panel for about 1 second.

Release the key when the display reads "SHUTTING DOWN."

When a job is present, it is automatically saved and will be printable the next time you turn the power on.

(Only when HDD is installed)



Note:

Even when "SHUTTING DOWN" appears, the power will not turn off until you release the power key.

SHUTDOWN
WAIT A MOMENT

This indicates that the device is executing a shut down.

When the shut down process has been completed, the power will turn off.

- 2** Turn the main power off when you are not using this device for an extended period of time.

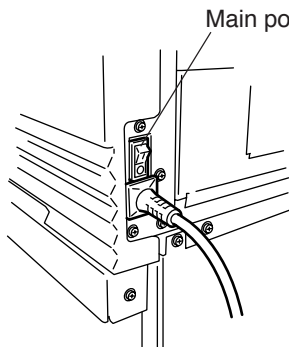

Press the power switch toward the ○ symbol (downwards).

When you first turn on the power after purchasing this device, it will start up differently from how it will regularly start up thereafter. A guidance display will prompt panel display language selection, initializing of parameters appropriate for your region, and the setting of an IP address. By setting this IP address when the plotter is installed, you will be able to utilize the browser of a host computer on the same network as the plotter to make various settings.

Moreover, when using the network to operate the device, you must also initialize the following plotter settings from the browser or the device panel. If you neglect to set these settings, connection with the router will not be possible.

- ① Subnet mask settings
- ② Routing table settings

Once you set the panel display language selection, initialized optimal setup parameters according to your region, and set IP address settings, this guidance display will not appear the next time the power is turned on. When “INITIALIZE” is executed in the System menu (explained later), the IP address will return to an unset condition, and the IP address setting guidance display will appear once again when the power is turned on.

Notes

- ◆ The panel display language selection allows you to select the language which will appear on the device control panel, and can also be set from “LANGUAGE” in the System menu.
- ◆ Initializing of the optimal parameters for your region for such items as media series can also be set from “INITIALIZE” in the System menu.
- ◆ The IP address is a communication parameter during Ethernet connection which is assigned specifically to each device.

■Turning on the power

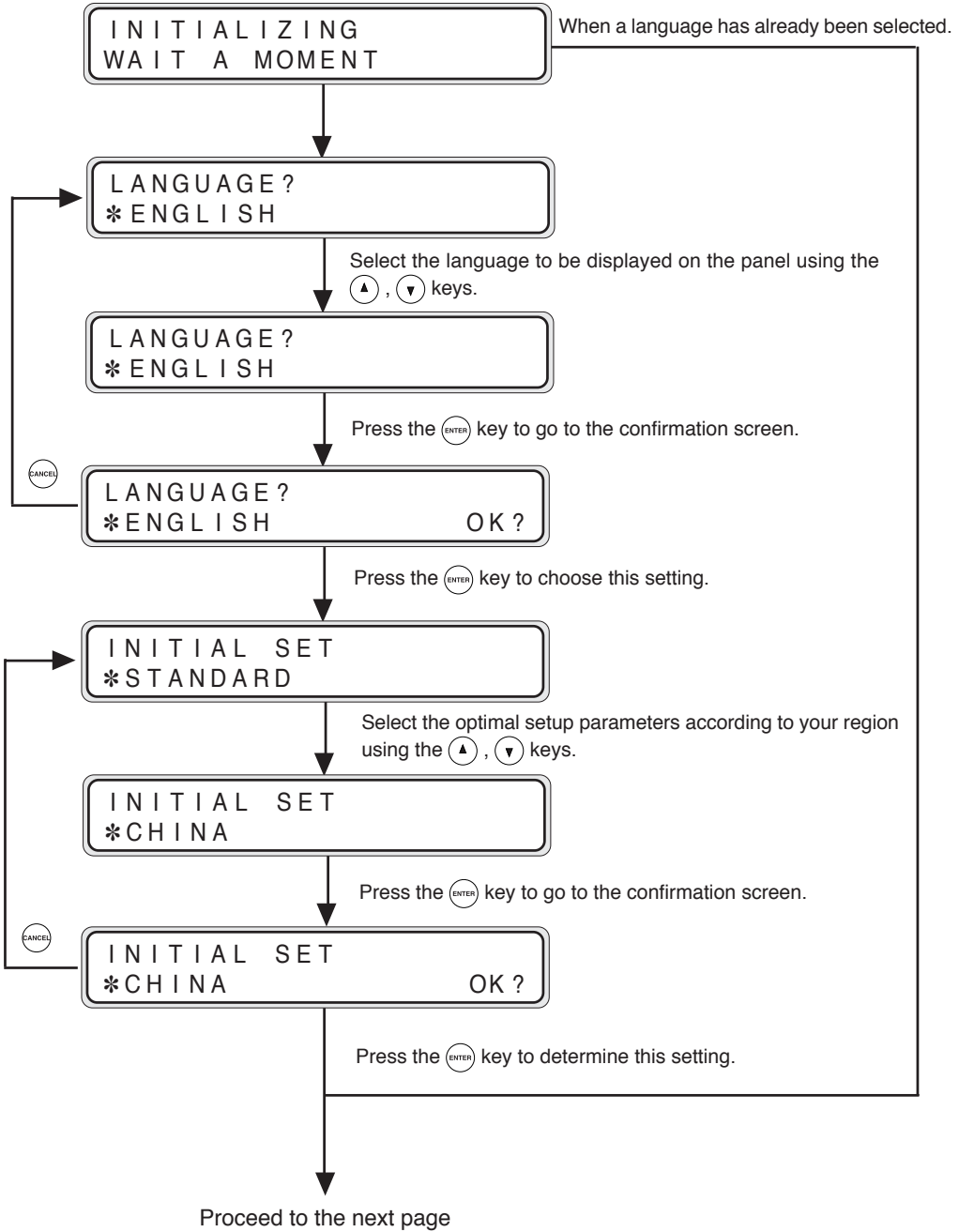

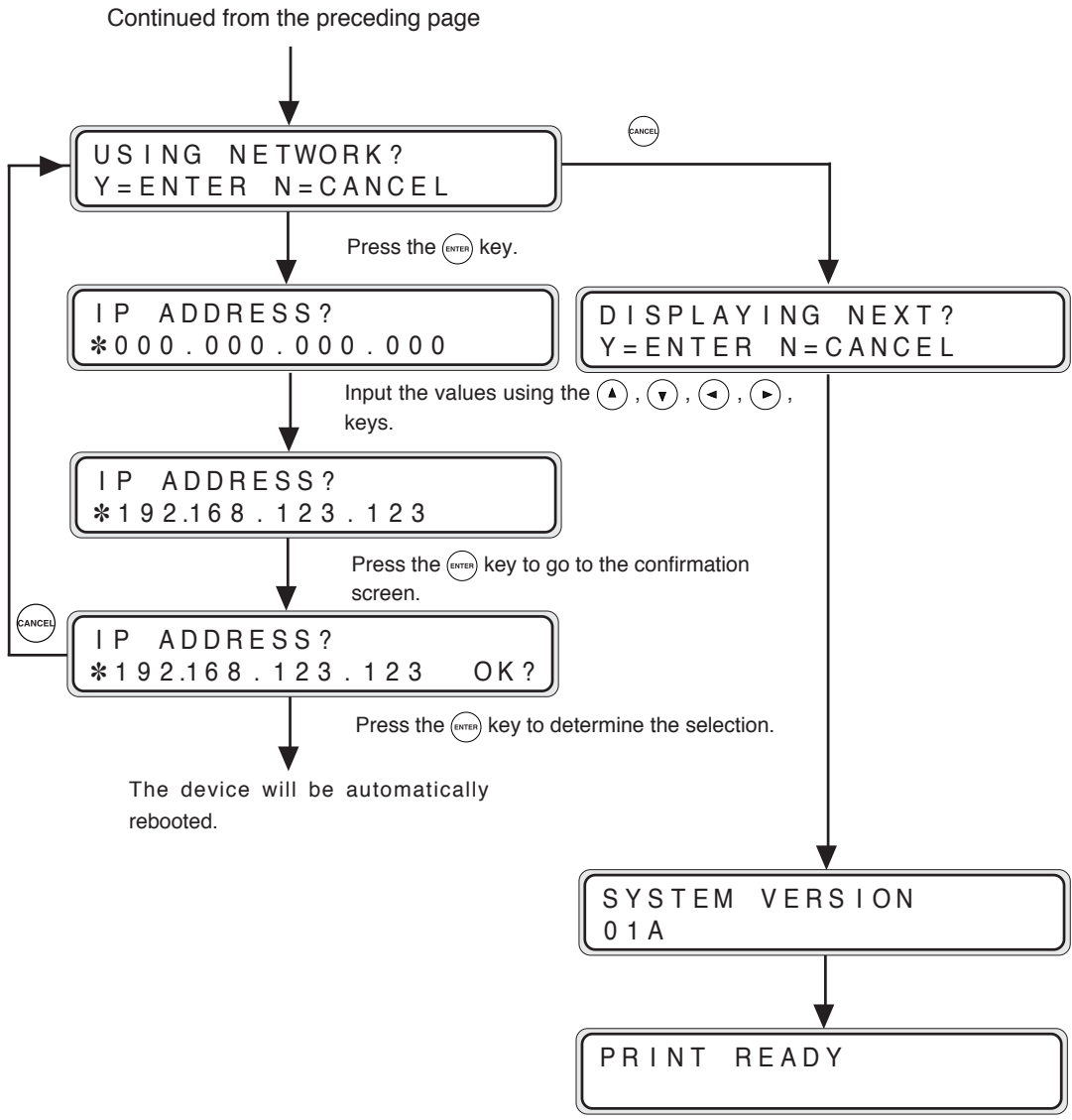

Online and offline

The device is “ONLINE” when it can receive and print data from the host computer and is “OFFLINE” when settings are being input on the control panel. You must set the device to “offline” to operate the menu from the control panel.

Online

To print from the host computer, the device must be online. Always make sure that the device is online to print from the host computer. If the device is not online, follow the procedures below to set the device online. The device will automatically go online when the device power is turned on.

- 1 Press the  key to turn the Menu lamp off.



PRINT READY

Offline

To select menu operations and paper feed method etc. using the device control panel, the device must be offline. Before using the control panel keys, set the device offline according to the following procedures.

- 1 Press the  key to turn the Menu lamp on.



MENU
SETUP

Replacing paper rolls

How to detach and reattach the paper rolls will be explained here.

Detach and replace a paper roll when the device has run out of paper or when you change the paper roll size on type. When the paper is used up during printing, the Error lamp will turn on and the LCD will display the following message:

Example: The screen requesting the A3 tracing paper to be loaded in the roll 1 drawer.

SET PAPER
A 0

or

SET PAPER
ROLL 1 A 0

or

SET PAPER
A 0 (TRACE)

or

SET PAPER
ROLL 1 A 0 (TRACE)



- ◆ When a paper replacement message appears on the LCD, it is possible to cancel the drawing that you sent to print. Use this function when you don't have the required paper.

Example)

SET PAPER
A 1

↓ Press the  key.

CANCEL PRINT ?

↓ Press the  key.
*Printing will be cancelled.

PRINT READY

If an error message about paper supply appears on LCD, paper of larger size than required (or, if a type of paper is specified, paper of different type) can be chosen for printing.

e.g.

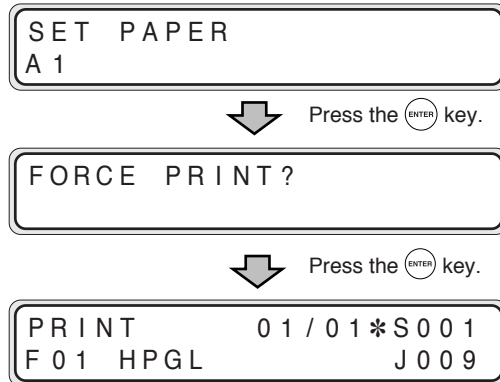

*Prints only when paper of larger size than required is available or if paper of a different type is available.

*Alternative print is disabled, if printing on the manually fed paper.

Notes

◆ "A1" in the above example indicates the paper roll width and its indication changes as follows:

Example:

A series:	"A0", "A1", "A2", "A3"
9" series:	"36\"", "24\"", "18\"", "12\""
8.5" series:	"34\"", "22\"", "17\"", "11\""
30x42 series:	"30\""
MAP series:	"707 mm", "500 mm"
DIN series:	"707 mm", "500 mm"
Chinese series:	"914 mm", "620 mm", "450 mm" "310 mm", "297 mm"

◆ When a paper type is specified as "SET PAPER A0 (TRACE)" and the paper roll is loaded, the display may be automatically switched to the paper menu. In such a case, set the type of the paper roll.

◆ If the media series is different (that is, appropriate media series was not loaded into the tray), the display may be automatically switched to the paper menu when the paper roll is reloaded. In such a case, set the media series of the paper roll.

Precautions during replacement

Caution

- ◆ The rolls are heavy so be careful not to hurt yourself by dropping them while you are replacing the rolls.
- ◆ When attaching the rolls, use a cutter to cut the end of the paper roll. While doing this, take care not to cut yourself or damage the device.
- ◆ When opening and closing the paper roll drawers, take care not to get your hands caught in the drawer.
Do not open other paper roll drawers while one paper roll drawer is open. Doing so will increase your chances of getting your hands caught in the drawers.

Notes

- ◆ If you change the paper type, you must also change the device settings accordingly. ⇒ chapter 7
- ◆ Use media types specified by our company.
If you use media types which are not specified by our company, we cannot assure printing quality.
- ◆ Store the paper in a cool, dark location with low humidity.

How to detach the paper rolls

1 Pull out the Roll 1 or Roll 2 drawer.

Use your fingers to grasp the handle in the center of the drawer and pull the drawer out gently.

(The diagram indicates a case where the Roll 2 drawer is opened.)

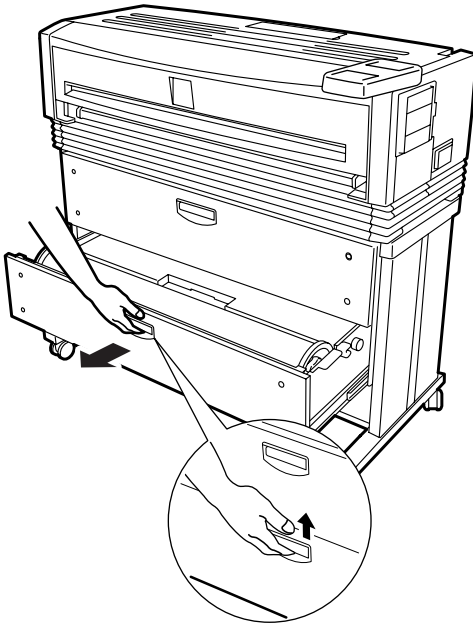

2 Rewind the paper roll and then remove it.

Turn the paper flange in the direction indicated in the diagram and continue to rewind the roll until you see the end of roll. Lift up the paper flange and remove the paper roll.

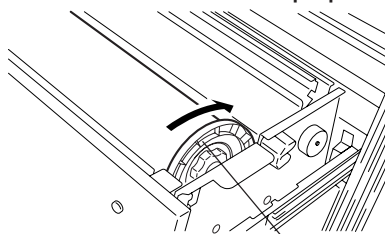

Paper flange

3 Remove the paper flange and take out the paper roll.

Loosen the paper flange by turning the knobs in the “OPEN” direction and remove both ends of the paper flange.

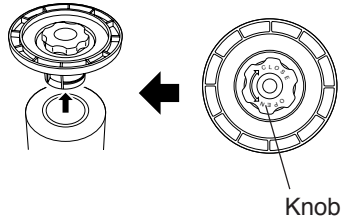

Note

- ◆ Take care not to use excessive force when you turn the paper flange knobs. The flange ends may come off.

How to attach the paper roll



- ◆ The paper flange ends do not have a designated right or left side. You can attach them to either side.

1 Attach the paper flange to a paper roll.

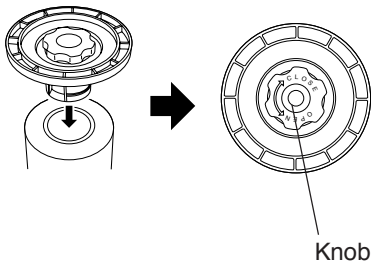

Push in the paper flange ends until they contact the paper roll tube, then secure the flange ends by turning the knob in the “CLOSE” direction.

Note

- ◆ If the paper flange knobs are loosely fitted, the paper roll will move adversely to the right and left and negatively affect the drawing. Make sure that the knobs are tightened securely.

2 Move the flange guide.

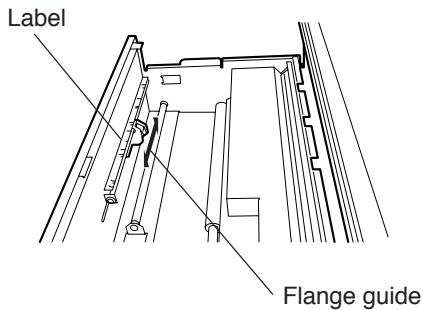

the label which is affixed to the inside of the drawer indicates the flange positions for the application of different roll widths. Move the flange guide to match the paper roll size you are using.

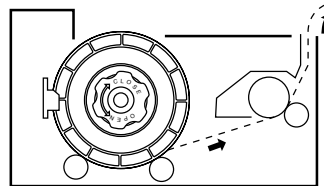

3 Load the paper roll into the drawer.

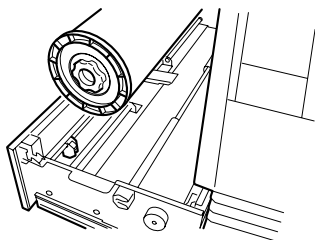

Hold the paper roll so that the end of the paper is positioned at the bottom facing the back of the device. Then align the paper flange to the depressions in the flange guide and gently insert the flange in place.

Note

- ◆ Take care not to drop the paper roll while performing these activities.

4 Insert the end of the paper roll into the paper feed inlet of the device.

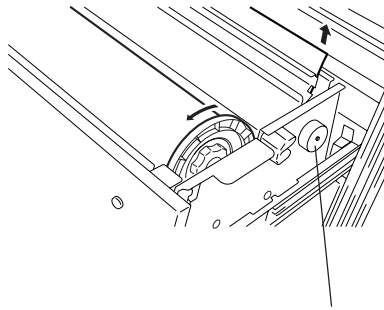

Paper feed knob

Turn the paper flange and insert the end of the paper roll so that it is straight. Turn the paper feed knob so that the end of the paper roll projects about 10 cm.

5 Cut the end of the paper.

While holding the end of the paper roll, cut it off with the cutter.

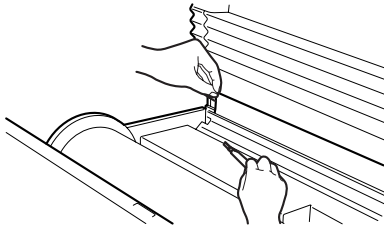

The “Paper cutter position” label is affixed to both ends of the space where the cutter blade should be inserted. Insert the cutter blade into the space where the label arrow is pointing. Slide the cutter blade along the space and cut the paper.



- ◆ The paper can be cut cleanly when the cutter is inserted in a perfectly sideways direction.

⚠ Caution

- ◆ Take care not to hurt yourself and damage the device when handling the cutter.
- ◆ Handle the cutter blade with care so that you do not break it.
- ◆ When sliding the cutter along the space, take care not to cut the back of your hand on the sides of the paper tray.

6 Close the paper roll drawer.

Gently push in the Roll 1 or Roll 2 drawer.

When the paper roll drawer is closed, the following message appears.

WAIT A MOMENT

(It will take about 30 seconds until paper feeding is ready.)

Note

- ◆ After closing the paper roll drawer, wait until the “WAIT A MOMENT” message disappears before opening the paper roll drawer again. As the device initiates a paper detection just after the paper roll drawer is closed, so opening the paper roll drawer during this operation may cause a paper jam.

After the replacement, the device will return to the status before the paper roll was replaced.

Note

- ◆ If you change the type of paper roll, you must change the corresponding settings, referring to “Paper settings” (⇒ page 7-2).

Replacing the toner

When the toner level runs low, the Toner lamp will flash. Although plots can still be produced under this condition, obtain a new toner cartridge as soon as possible and replace the toner.

When there is no more toner available, the Toner lamp will go out, the Error lamp will come on, and printing will no longer be possible. The following message appears on the LCD.

SET TONER CARTRIDGE
OPEN LEVER

If the Toner lamp starts flashing or the ERROR message appears, replace the toner according to the procedures indicated below.



Tips

- ◆ When you open the toner door, you will find a “Toner replacement” label affixed to the inside surface. Refer to this when replacing toner.
- ◆ After the Toner lamp starts flashing, approximately 50 m of plots can be produced at normal size and density.

Note

- ◆ If plots with a high printing rate—such as drawings containing many solid print areas and inversed (black and white inverted) drawings—are printed just before the toner runs out, the toner may be used up and the device may be damaged.

To avoid such a case, refill toner as soon as possible when the toner lamp is flashing.

Precautions on handling

Warning



Do not throw empty toner cartridges into fire. Doing so may cause accident and fire.

Put the waste cartridge into the wrapping contained in the toner cartridge package and dispose of it as non-burnable garbage.

Caution

- ◆ Do not drop and tap the toner cartridge with force. Doing so may cause the toner to leak from the cartridge.
- ◆ Do not directly touch the toner. If the toner gets on your skin or clothing, quickly wash it off with water.
- ◆ Take care not to get toner in your eyes or breathe it in. If the toner gets in your eyes, wash your eyes out with lots of water and consult your physician.

Notes

- ◆ If you move the toner cartridge from a cold to a warm location, leave it in room temperature for over three hours before using it.
- ◆ After replacing the toner, try to use it up within a six month period. A toner cartridge installed for an extended period of time will degrade the drawing quality.
- ◆ Keep toner cartridges in a cool, dark place.
- ◆ Use only genuine toner cartridges.

Toner replacement procedures

Notes

- ◆ Toner should be replaced only when the device power is On. If the toner is replaced while the power is Off, the device will not be able to detect the amount of toner and an error status will not be cancelled even when toner has been replaced correctly.
- ◆ Replace toner after plotting finishes. Replacing the toner during plotting may cause the operation to stop and the plotting data to be lost.

1 Open the toner cover.

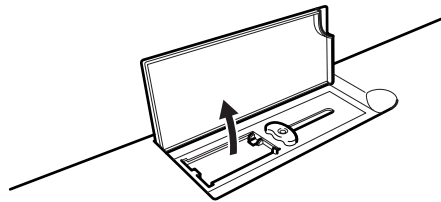

2 Take out the new toner cartridge from the package.

3 Mix the toner by shaking the new toner cartridge.



Shake it strongly up, down, left and right, five or six times.

4 Set the toner cartridge into the main unit.

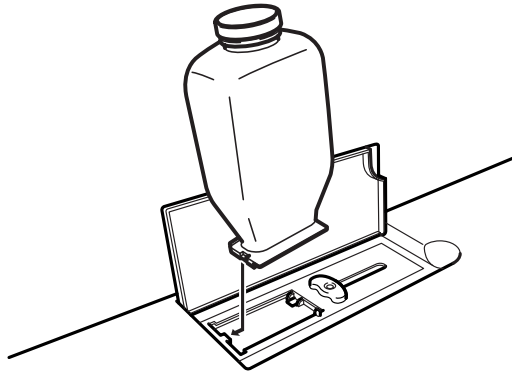

5 Pull the lever to the right end.

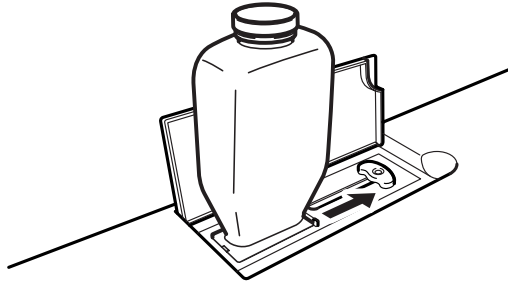

At this time, the following message appears on the LCD. After performing the procedure **6** operation, return the lever and remove the toner cartridge.

CLOSE LEVER
REMOVE CARTRIDGE

If the above message does not appear, check to see that the lever has been pulled up to the right end.

- 6 Tap the cartridge to allow toner to drop down.



- 7 Return the lever to the left.



- 8 Remove the toner cartridge and close the cover.

At this time, the following message appears on the LCD.

WAIT A MOMENT

Replacing the waste toner bottle

When the waste bottle is nearly full with waste toner, the Waste toner lamp will flash. Although plots can continue to be produced for a little while longer, replace the waste bottle soon.

When the waste bottle becomes full with waste toner, the Waste toner lamp will go out. The Error lamp will turn on and plotting will not be possible. The following message appears on the LCD.

CHANGE
WASTE BOTTLE

If the Waste toner lamp starts flashing or the message appears on the control panel, replace the waste bottle in accordance with the procedures outlined below.



- ◆ A “Waste bottle replacement” label is affixed to the side of the waste toner bottle. Refer to this when replacing the waste bottle.
- ◆ Even after the Waste toner lamp starts flashing, you should be able to produce about 120 m of plots.

Precautions during replacement

Warning



Do not throw waste bottles containing waste toner into fire.
Doing so may cause an accident and fire.
Dispose of waste bottles as non-burnable garbage.

 **Caution**

- ◆ Do not drop and hit waste bottles containing waste toner. Doing so may cause toner to leak.
- ◆ Take care not to directly contact the waste toner. If the toner gets on your skin or clothing, quickly wash it out with water.
- ◆ Take care not to get the waste toner into your eyes or breathe it in.
If waste toner gets into your eyes, wash your eyes out with plenty of water and consult a physician.

Notes

- ◆ Replace the waste bottle after plotting has been completed. If replacement is attempted during plotting, the plotting data may be lost.
- ◆ The toner inside the waste bottle cannot be re-used.

Waste toner bottle replacement procedures

- 1** Take out a new waste toner bottle from its package and remove the cap.



- ◆ This cap should be used to cover the waste toner bottle which you are removing, so keep it at hand. ⇒ procedure 4.

- 2** Open the waste toner bottle door.

The waste bottle door is located at the right side of the device.

3 Remove the waste toner bottle from the main unit.

- ① Lift up the waste bottle,
- ② Remove it by pulling it out from the bottom end toward you.

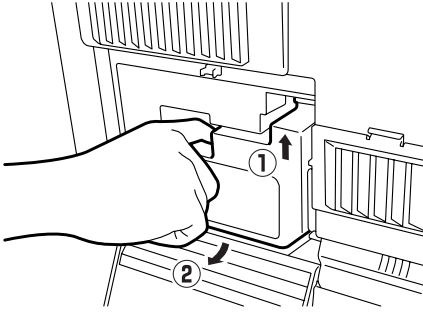

When you have removed the waste toner bottle, the LCD will display the following message.

SET
WASTE BOTTLE

4 Attach the cap to the waste toner bottle.

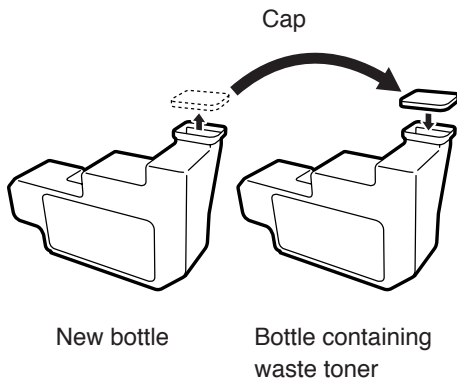

Attach the cap which you have removed in procedure 1 to the waste bottle containing waste toner.

Dispose of the waste bottle containing waste toner as non-burnable garbage.

Note

- ◆ Attach the cap securely as it may come off.

5 Attach a new waste toner bottle.

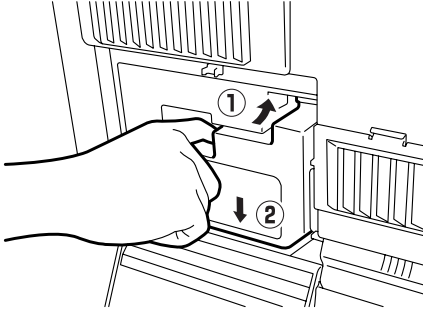

- ① Insert the mouth of the waste toner bottle onto the waste toner discharge port of the main unit by slightly lifting it.
- ② Set it onto the bottom surface and position it so that it is stable.

After the following message appears, the device status will return to the status before the waste bottle was replaced.

WAIT A MOMENT

6 Close the waste door.

Replacing the process cartridge

When the Process cartridge approaches the end of its life, the Process lamp flashes and the following message appears. It is still possible to continue to produce plots in this condition, but you must replace the cartridge soon.

PRINT READY
REPLACE PROCESS

Note

◆ Above message may not appear in certain cases.

If a new process cartridge is not installed soon, the Process lamp goes out, Error lamp comes on and plotting becomes impossible. The following error message appears on LCD.

SET
PROCESS CARTRIDGE

When the Process lamp flashes or goes out, follow the procedures indicated below to replace the Process cartridge.

Precautions during replacement

Warning



Do not throw the process cartridge into fire. Doing so may cause accident and fire.
Dispose of process cartridge as non-burnable garbage.

Notes

- ◆ Until you are ready to install the Process cartridge, do not unpack it and store it in its cardboard container.
- ◆ Firmly hold the handles on both sides with both hands when handling the Process cartridge.
- ◆ Take care not to scratch the surface of the photoconductor drum during handling.
- ◆ With the exception of the handle area, take care to avoid contacting the surface of the photoconductor drum as much as possible.
- ◆ Except when you install the Process cartridge into the device body, keep the cover on the Process cartridge cover to protect the photoconductor drum and to prevent optical deterioration.
- ◆ Some black developing toner may be visible on the photoconductor drum of a new Process cartridge. This is to ensure that the cartridge is kept in a ready-to-use condition at all times, so you may use it as it is. After the cartridge is mounted on the device body, cleaning will automatically start so you need not worry about the liquid affecting printing quality.
- ◆ Since waste toner remains in the used Process cartridge, take care not to shake it strongly, tilt it sharply, or hit it with force as this may cause waste toner to spill out.

Process cartridge replacement procedures

- 1** Turn off the device power and open the top cover.

2 Take out the Process cartridge.

Pull the Process cartridge out by holding onto its handles.

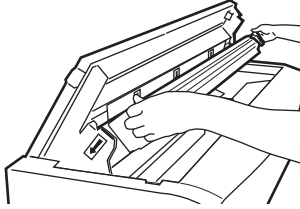

3 Place a new Process cartridge on the top of the device.

- ① Remove the Process cartridge from the box together with its protective case.
- ② Place the Process cartridge on the top of the device together with the protective case.

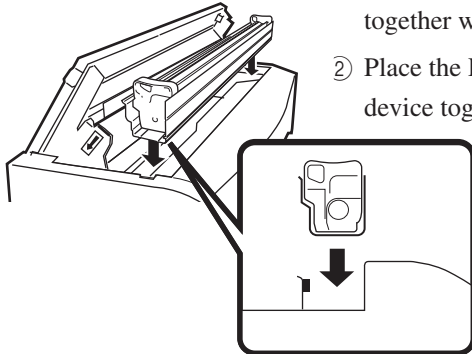

Two types of filters for replacement use are contained in the process cartridge packaging box. Replace the filter after replacing the process cartridge.

4 Remove the orange tape.

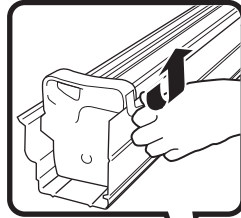

Remove the orange tape affixed to the Process cartridge (4 points).

A sheet is attached to the tape at (2 points) on the inside. Remove the sheet together with the tape.

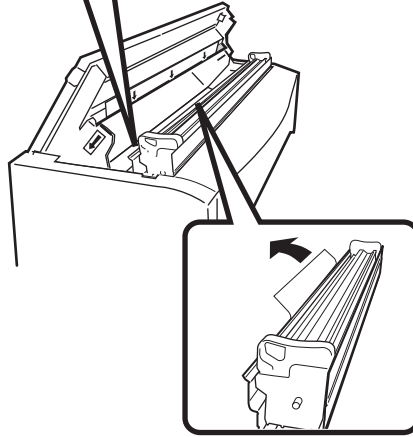

5 Remove the Process cartridge from its protective case.

While holding onto the handles, open the protective case while pushing with your thumbs and remove the Process cartridge from the protective case.

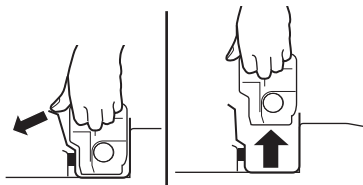

6 Insert the Process cartridge.

To insert the Process cartridge, align the Process cartridge with the angle of the open top cover and insert it in the direction of the alignment arrows (three points/green).

After insertion, remove the protective cover from the top of the cartridge.

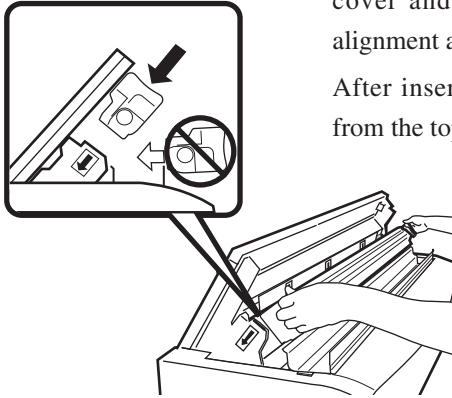

7 Close the top cover.

8 Remove the filter cover.

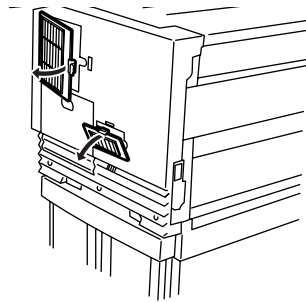

Pull out the filter covers at 2 points on the right side of the main unit as it faces you, and remove them.

9 Replace the filter.

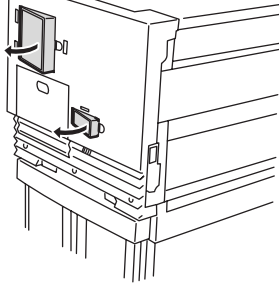

Pull out the filters toward you and remove, and replace with the two filters contained in the process cartridge packaging box.

10 Attach the filter covers and turn ON the device.

Manual paper feeding (cut paper)

This device offers a manual feeding feature as a service function.
As this is a service function, we cannot assure the picture quality and printing accuracy.

Manual feeding procedures

1 Adjust the paper guide.

Adjust the paper guide to the position where you will set the cut paper for manual feeding.

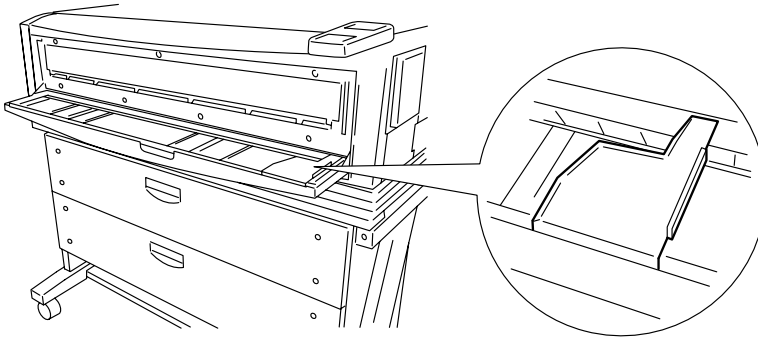

2 Set the paper so that the printing surface is face down.

When you insert the paper into the manual paper feed inlet, the paper is drawn in and the paper is ready for printing.

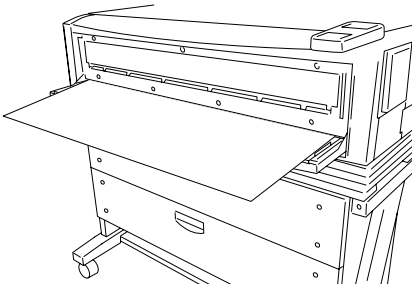

Manual paper feeding procedure

1 Set the paper feeding mode.

When the PDL setup paper feeding mode is set to the continuous or optimum mode, paper should be manually fed only for the drawings for which the data was processed immediately after the paper was fed into the manual paper feeding unit (this function is called "interrupt manual feeding function".)

When the PDL setup paper feeding mode is the manual feeding mode, paper should be always fed from the manual paper feeding unit. If no paper has been fed into the manual paper feeding unit when data is transferred, paper to be used is indicated on the operation panel (this function is called "continuous manual paper feeding function".)

Refer to page 5-12 for details of the paper feeding mode.

2 Load the cut paper.

Cut paper as listed below can be used with this device.

A series fixed form cut paper

Name of fixed form	Lengthwise length	Widthwise length
A0	1189 mm (46.8 inches)	841 mm (33.1 inches)
A1	841 mm (33.1 inches)	594.5 mm (23.4 inches)
A2	594.5 mm (23.4 inches)	420.5 mm (16.6 inches)
A3	420.5 mm (16.6 inches)	297.3 mm (11.7 inches)
A4	297.3 mm (11.7 inches)	210.3 mm (8.3 inches)

A series width cut paper

Width name	Paper width	Paper length
A0 width	841 mm (33.1 inches)	Max. up to printing length
A1 width	594.5 mm (23.4 inches)	
A2 width	420.5 mm (16.6 inches)	
A3 width	297.3 mm (11.7 inches)	

9× 12 series fixed form cut paper

Name of fixed form	Lengthwise length	Widthwise length
E	1219.2 mm (48 inches)	914.4 mm (36 inches)
D	914.4 mm (36 inches)	609.6 mm (24 inches)
C	609.6 mm (24 inches)	457.2 mm (18 inches)
B	457.2 mm (18 inches)	304.8 mm (12 inches)
A	304.8 mm (12 inches)	228.6 mm (9 inches)

9× 12 series width cut paper

Width name	Paper width	Paper length
E width	914.4 mm (36 inches)	Max. up to printing length
D width	609.6 mm (24 inches)	
C width	457.2 mm (18 inches)	
B width	304.8 mm (12 inches)	

8.5× 11 series fixed form cut paper

Name of fixed form	Lengthwise length	Widthwise length
E	1117.6 mm (44 inches)	863.6 mm (34 inches)
D	863.6 mm (34 inches)	558.8 mm (22 inches)
C	558.8 mm (22 inches)	431.8 mm (17 inches)
B	431.8 mm (17 inches)	279.4 mm (11 inches)
A	279.4 mm (11 inches)	215.9 mm (8.5 inches)

8.5× 11 series width cut paper

Width name	Paper width	Paper length
E width	863.6 mm (34 inches)	Max. up to printing length
D width	558.8 mm (22 inches)	
C width	431.8 mm (17 inches)	
B width	279.4 mm (11 inches)	

30× 42 series fixed form cut paper

Name of fixed form	Lengthwise length	Widthwise length
30× 42	1066.8 mm (42 inches)	762.0 mm (30 inches)

30× 42 series width cut paper

Width name	Paper width	Paper length
30"	762.0 mm (30 inches)	Max. up to printing length

Map series fixed form cut paper

Name of fixed form	Lengthwise length	Widthwise length
B1	1000.0 mm (39.4 inches)	700.0 mm (27.6 inches)
B2	700.0 mm (27.6 inches)	500.0 mm (19.7 inches)

Map series width cut paper

Width name	Paper width	Paper length
B1 width	700.0 mm (27.6 inches)	Max. up to printing length
B2 width	500.0 mm (19.7 inches)	

DIN series fixed form cut paper

Name of fixed form	Lengthwise length	Widthwise length
B1	1000.0 mm (39.4 inches)	707.0 mm (27.8 inches)
B2	707.0 mm (27.8 inches)	500.0 mm (19.7 inches)
B3	500.0 mm (19.7 inches)	353.0 mm (13.9 inches)

DIN series width cut paper

Width name	Paper width	Paper length
B1 width	707.0 mm (27.8 inches)	Max. up to printing length
B2 width	500.0 mm (19.7 inches)	

Chinese series width cut paper

Width name	Paper width	Paper length
914 mm width	914 mm (36 inches)	Max. up to printing length
910 mm width	910 mm (35.8 inches)	
900 mm width	900 mm (35.4 inches)	
880 mm width	880 mm (34.6 inches)	
620 mm width	620 mm (24.4 inches)	
610 mm width	610 mm (24 inches)	
450 mm width	450 mm (17.7 inches)	
440 mm width	440 mm (17.3 inches)	
310 mm width	310 mm (12.2 inches)	
297 mm width	297 mm (11.7 inches)	

When feeding the cut paper into the manual paper feed inlet, follow the procedure below (position the cut paper in the center of the manual paper feed inlet).

When plotting on the fixed form paper, set the paper as shown below (the paper input direction varies depending on the fixed form paper size).

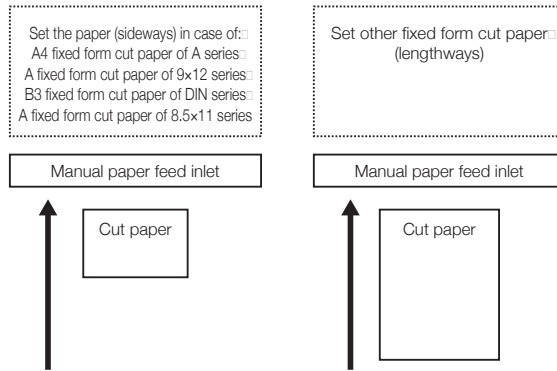

When plotting at the actual length or expanded size of a fixed form, load the paper as shown below (paper should be always set lengthways).

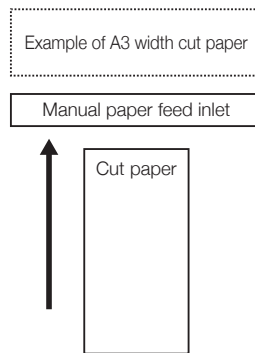



After the cut paper is properly fed into the manual paper feed inlet, the device pulls the paper into it.

Notes

- ◆ When the paper is manually fed, printing is made only on one sheet of paper even if the number of prints is set to more than two.
- ◆ Even if the correct size cut paper is not used, printing takes place when cut paper is fed into the device. In this case, the drawing may be missing in part.

Pause, continue, cancel (and additional printing)

Pressing the  key during printing takes the device offline and allows you to temporarily stop printing by pressing the  key.

Pressing the  key during printing gives you the option to cancel the drawing being printed.

Pressing the  key during Print stop status allows the device to be returned to Online status and to continue printing.

Print stop

Press the  key during printing and set the device to Print stop status. When a drawing has already begun printing, printing will be stopped after the printing of that drawing is completed. Printing of the next drawing will not be executed.

The Print stop status appears on the following offline display and enables each offline process to be executed.

```
MENU
# SETUP
```

Continue printing

From the Print stop status, pressing the  key again returns the device to online status and it will continue printing.

```
PRINT      01 / 01 * S001
F01 HPGL           J009
```

Cancel printing

Press the  key during printing and the following Cancel message will appear. After a Print cancel is processed, the display will return to the Online display.

CANCEL PRINT?
F01 HPGL J009

Press the  key. 

PRINT READY

Additional printing



In the data standby condition, the same drawing as that printed last (called "accumulated drawing") can be additionally printed. At this time, the number of copies can be also specified.

PRINT READY

Press the  key. 

STACK PRINT?
COPIES = 1

Press the  key. 

No. of copies can be changed using the  and  keys (up to 20 copies).

STACK PRINT 01 / 01

If no drawing has been stored or "accumulated", the device is not activated.

The stored drawings can be erased by pressing the  key in the data standby condition.

Through your Web browser, you can use the following functions remotely from a host computer.

In order to use these functions, it is necessary to have the device IP address preset.

Moreover, it is necessary to have the browser set to enable Cookies and JavaScript. For information on the setting method, refer to the Help menu for your host computer's browser (or OS).

Functions

(1) Device status display function

This function allows you to check the status of the device etc. from the host display screen. You will be able to monitor job execution status and error occurrences remotely.

(2) Setup reference/change function

Printing parameters etc. set for the device can be reviewed to and changed on the host screen.

(3) Job control function

This function allows you to view job information details, and conduct reprinting of already printed jobs from the host side.

(4) Remote maintenance function

This function allows you to check the job or error records when a problem occurs, as well as to upgrade the system Firmware.

Web function startup method

1 The following preparations must be made from the plotter side.

- ① Turn on the plotter power.
- ② Confirm the IP address setting. (If this setting has not yet been set, set this setting according to the instructions which appears when the device is booted).
- ③ Set each Ethernet parameter where necessary.

2 Launch the Web browser.

- ① Obtain the Web browser for the host computer.
 - Microsoft Internet Explorer Ver11.5 and later
 - Netscape Communicator Ver5.0 and later
- ② Launch the Web browser.
- ③ Enter “http:// the IP address set to the device/” into the address column and press the Enter key.

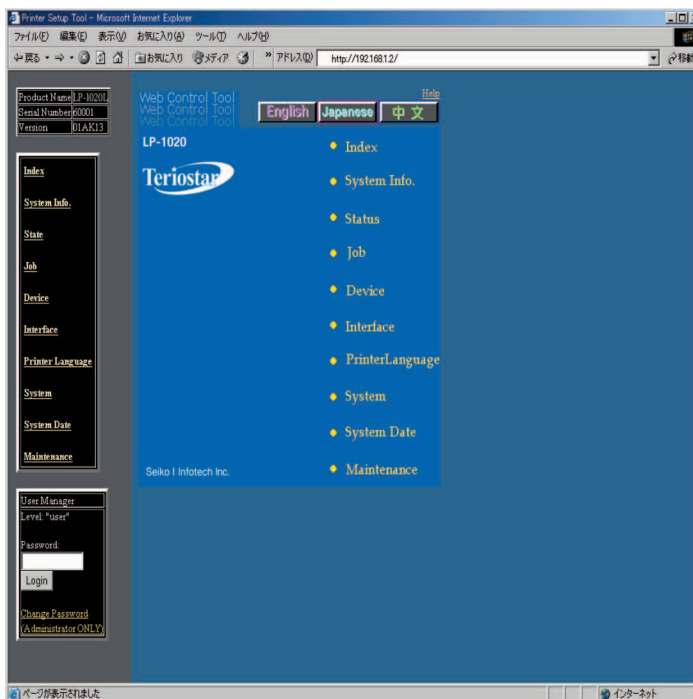

Cleaning the exterior

To clean the exterior of the device, soak a soft cloth with water or a neutral detergent, and wring the cloth well and wipe away dirt.

Note

- ◆ Never use a volatile solvent such as a thinner, benzine, and alcohol.

Using paper of new standard series

This device supports the following series of paper.

A series
9×12 inch series
8.5×11 inch series
30×42 inch series
Map series
DIN series
Chinese series

The device is set up when shipped out of the factory so as to support the A series or A and Chinese series. You can check for which series your device is currently set up for by the enable series (page 11-5) (any series having been set to ON can be used).

The steps to add new series are added is described below. The 8.5×11 inch series is taken as an example. The process is also applicable to other series. When using the Chinese series, refer to “When using paper of China series (page 2-45)”.

(1) Adding new media series

Set the 8.5 series to ON in the enable series screen (page 11-5).

Note

- ◆ All the series cannot be set to OFF at the same time.
- ◆ When this setting is changed, the device must be restarted.

(2) Change the apply roll setting

The 34, 22, 17 and 11-inch rolls can be used for the 8.5×11 inch series. Set the roll to be actually used to ON in the apply roll setting process (page 11-7).

It is recommended to set other rolls to OFF.

When using only the cut paper of the 8.5×11 inch series, this step is not needed.

Note

- ◆ All of the apply rolls of the same series cannot be set to OFF at the same time.
- ◆ If this setting is changed, the device must be restarted.

(3) Place the roll in the drawer

Load the roll of the 8.5×11 inch series to be used into the roll paper drawer.

See page 2-16 for instructions on loading the paper roll.

When using the cut paper of the 8.5×11 inch series, this step is not needed.

(4) Setting the paper menu

Set the media series of the drawer into which the roll of the 8.5×11 inch series was set to the 8.5" series (page 7-2).

When using the cut paper of the 8.5×11 inch series, this step is not needed.

(5) PDL setup

Set the auto media series of the PDL setup for the port to transfer the data to 8.5" series (page 5-11).

(6) If not operated as expected

If the preset series does not work as expected, check the process from steps 1 to 5 again.

Using paper of Chinese standard series

Rolls of the China series listed below can also be used with this device. Plotting of the fixed form cannot be performed with the roll of the China series. All the plots produced in this mode are in the actual length.

China A0 roll width	China A1 roll width	China A2 roll width	China A3 roll width
914 mm (36 inches)	620 mm (24.4 inches)	450 mm (17.7 inches)	310 mm (12.2 inches)
910 mm (35.8 inches)	610 mm (24 inches)	440 mm (17.3 inches)	297 mm (11.7 inches)
900 mm (35.4 inches)	-	-	-
880 mm (34.6 inches)	-	-	-

Operation when using the China series is described below.

(1) Adding new media series

Set the China series to ON in the valid series setting process (page 11-5).

Note

◆ If this setting is changed, the device must be restarted.

(2) Setting the China size

Four types of A0 width, 2 types of A1 width and 2 types of A2 width of the China series can be used. Set the required width in the Chinese size (page 11-8).

Note

◆ If this setting is changed, the device must be restarted.

(3) Change the apply roll setting

Set the roll used to ON in the apply roll setting process (page 11-6).

It is recommended to set rolls not to be used to OFF.

When using the cut paper of the China series only, this step is not needed.

Note

- ◆ All of the rolls of the China series cannot be set to OFF at the same time.
- ◆ If this setting is changed, the device must be restarted.

(4) Place the roll in the drawer

Place the roll of the China series to be used in the drawer. Refer to the page 2-15 for instructions on replacing the paper roll.

When using the cut paper of the China series only, this step is not needed.

(5) Setting the paper menu

Set the media series of the drawer in which the roll was set to the China series (page 7-2).

When using the cut paper of the China series only, this step is not needed.

(6) PDL setup

Set the auto media series of the PDL setup for the port to transfer the data to the China series (page 5-11).

When the China series is operated with the printer driver, set the printer driver to Chinese (page 5-24).

(7) If not operated as expected

If the China series having been set up does not work as expected, check the process from steps 1 to 6 again.

Limiting rolls to be used

When limiting rolls to be used for operation to A0 and A1 rolls, for example, the following process is recommended.

(1) Setting the apply roll

Set the rolls to be used to ON in the apply roll setting process (page 11-6).

Set the rolls not used to OFF.

When using only the A0 and A1 rolls, for example, set as follows:

Use A0 roll = ON

Use A1 roll = ON

Use A2 roll = OFF

Use A3 roll = OFF

(2) In case of no paper

If there is no paper when starting to print with this device, reloading of paper will be prompted on the control panel. At this time, rolls which have been set to OFF in the setting of apply rolls are not required.

(3) In case of optimum mode

When the auto supply mode is set to the optimum mode (page 5-12), a roll which will leave the least wasted paper will be automatically selected from the rolls having been set to ON in the apply roll setting process. If the roll with the least remainder is not installed on the device, loading paper will be required by the control panel.

Chapter 3

Menu overview

Chapter 3 provides an overview of the menu functions covered by this device.

Contents of this chapter

Channels and ports

Data format

Job

Setting menu

PDL menu

Items which you can set

Menu screen

Channels and ports

This device is equipped with standard Ethernet interface connectors. The Ethernet interface has 10 logical ports. Moreover, the device is capable of parallel and USB interface connection when the device has been equipped with these 2 types of interface. This allows the device to receive data from up to 12 computers simultaneously.

This device has 4 types of plotting parameter tables for each port on the Ethernet interface, 4 types for the parallel interface, and 1 type for the USB interface, for a total of 45 available types.

Each parameter table is set in "SETUP MENU." To use the ports, it is necessary to enable the Ethernet parameters corresponding to each port beforehand in "SYSTEM MENU."

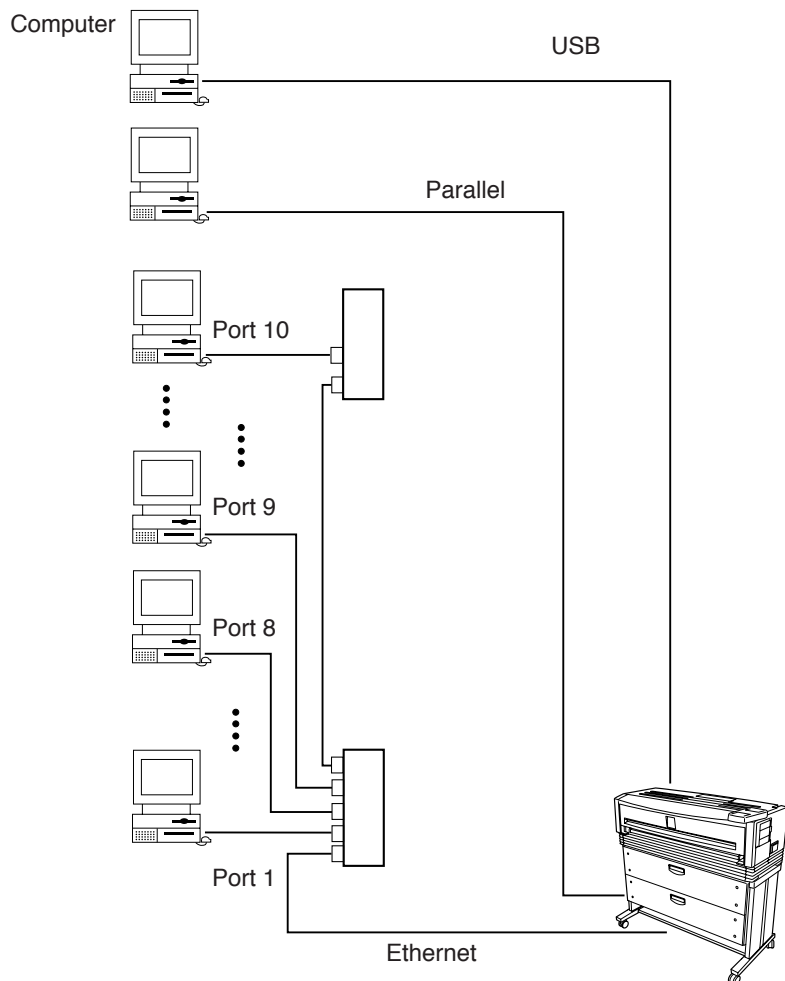

Data formats

Data formats which can be used

This device supports the data formats indicated below.

■ Data formats

LCD Display	Data formats
DSCAN	This is our company's original D-SCAN format. It also supports D-SCAN Raster data.
HPGL	Supports our company's D-SCAN C/C2 format. (hereafter referred to as HP-GL format.)
TIFF	A data format conforming to TIFF Revision 4.0
CALS	A data format conforming to CALS Raster Type I.



Tips

- ◆ It is necessary to specify in “PDL SELECT” (⇒ page 9-3) which data format the received data will be processed as.
- ◆ DSCAN/C2 format is a data format conforming to the command system of HP company indicated below:
 - D-SCAN C format: conforming to HP-GL
 - D-SCAN C2 format: conforming to HP-GL / 2, HP RTL
- ◆ For details on the commands supported by this device, refer to “COMMAND LIST” in the appendix.
- ◆ In this manual, the above data formats are collectively referred to as PDL.

Data format auto-judging

This device is equipped with a function to automatically recognize and process the format of the received data.

This function allows data of different formats to be sent to a single channel or port and to have this data plotted.

There are 4 formats which can be judged: D-SCAN format, HP-GL format, TIFF, and CALS format.

The data format auto-recognition function cannot be used for the USB channel. For the USB port, connect our company's printer driver.

Jobs

The device manages the received data in units of “jobs.” Data transferred in units of “FILES” and data managed by the device in units of “JOBS” refer to the same thing.

However, as data comprised of multiple drawings can also managed as a single job. So one print job isn’t necessarily composed of one drawing. For all print jobs, the print status of the job can be checked from the remote control, the print order can be changed, and reprinting etc. is available.

Reprinting

By using the “REPRINT” function in the Job menu, pre-processed jobs can be moved to the top of the list of jobs standing by to be processed. This function allows you to reprint jobs which have already been printed. Also, at the time of printing you can specify the number of copies and change printing parameters.

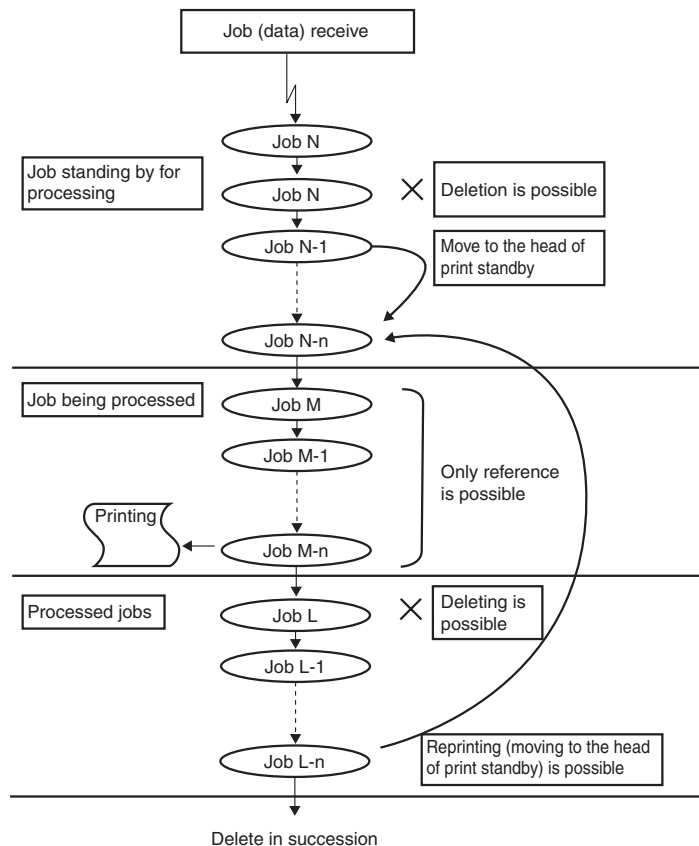

Settings menu

This device has menus for setting printing parameters, system settings for the entire device, communication protocols, and operation status settings for the device engine.

- | | |
|-----------------|---|
| ① Setup menu | Sets printing parameters etc. |
| ② System menu | Sets system settings for the entire device. |
| ③ Protocol menu | Sets communication protocol settings. |
| ④ Device menu | Sets operating status settings for the device engine. |

Moreover, this device has four Print parameter setup tables to be used independently for each of the parallel channels and Ethernet ports. These tables can be set from the Setup menu (this Setup table is referred to as the PDL table hereafter).

These four PDL tables can be assigned to each channel or port via “PDL SELECT” in the Protocol menu (the USB channel cannot be changed). Set the number of ports you use and the protocol type in “PORT SELECT” from Communication parameters in the System menu.

(1) Setup menu

Change the settings for each PDL in Setup menu listed below:

Menu name	
Setup	— PORT n_HPGL — PORT n_DSCAN — PORT n_TIFF — PORT n_CALS : — PARA_CALS — USB_HPGL

Note:

Disabled ports will not be indicated (refer to Port select in the System menu).

Only the PDL selected via PDL Select is displayed (refer to PDL Select in the Protocol menu).

Parallel and USB will only be indicated when each interface is installed. USB will only indicate HPGL.

(2) Protocol menu

For each parallel channel and port in the Protocol menu, select the PDL numbers in “PDL SELECT” as listed below. When the Protocol menu is changed, system reset is executed.

Menu name	Port number : Protocol name	
Protocol	—PORT 1 :XPT	—PDL SELECT —XPT PORT
	—PORT 2 : LPD	—PDL SELECT —PRINTER NAME
	—PORT 3 : FTP	—PDL SELECT —USER NAME
	⋮	⋮
	—PARALLEL	—PDL SELECT

Note:

You can set the ports you use in Ethernet parameters in System menu (initial parameter is 3 ports).

(3) System menu

Set the number of ports you use and the protocol types in System menu listed below:

Menu name				
System	—COMM. PARAM.	—ETHERNET	—PORT SELECT :	—XLF (Refer to “Note” below.)
		—PARALLEL	—TIMING MODE :	
		—USB	—TIMEOUT (sec)	

Note:

FTP, XPT, and LDP comprehensively allow for 10 ports to be set.

Initial parameter is 1 port for each protocol. (XLF)

Setting example: # PORT SELECT 1-10

> F F F X X X L L L – In case of 3 ports for each protocol

PDL menu

The various print parameters can be set in the PDL table from the Panel setup menu. The PDL processing program performs print processing in accordance with the print parameter settings.

Setting each print parameter allows for convenient operation by allowing you to change how paper is fed and delivered, and enables you to reduce the scale of a drawing.

When using our company's printer driver

When using our company's printer driver (when the print driver "OPTION SHEET" from "OUTPUT PROCESS SELECT" in "FORMAT" has been set to C2VR), the printer parameters set for this device are disabled and printing is performed in accordance with the print parameters set for the print driver (printing in accord with the print driver settings).

If you wish to enable the PDL menu print parameters using our company's print driver, go to Format parameters and set the "PRINT DRIVER" to "DISABLE" (initial parameter is print driver: disabled).

"PRINT DRIVER" **ENABLE** / DISABLE / CHINESE

However, as all print parameters set for the printer driver are disabled by this action, set the each print parameter as required on the device.

To operate the device with China series paper using the print driver, set the print driver to Chinese. In this case, operation will be performed as base table plotting.

Items which you can set

Set the device offline before performing setting operations. When you press  to set the device offline, the following message appears on the display.

Changed parameters are saved in non-volatile memory and are not lost when the power is turned off.

Although the offline display appears even while printing, there are functions which cannot be operated and these menus will not be displayed.

Idle status

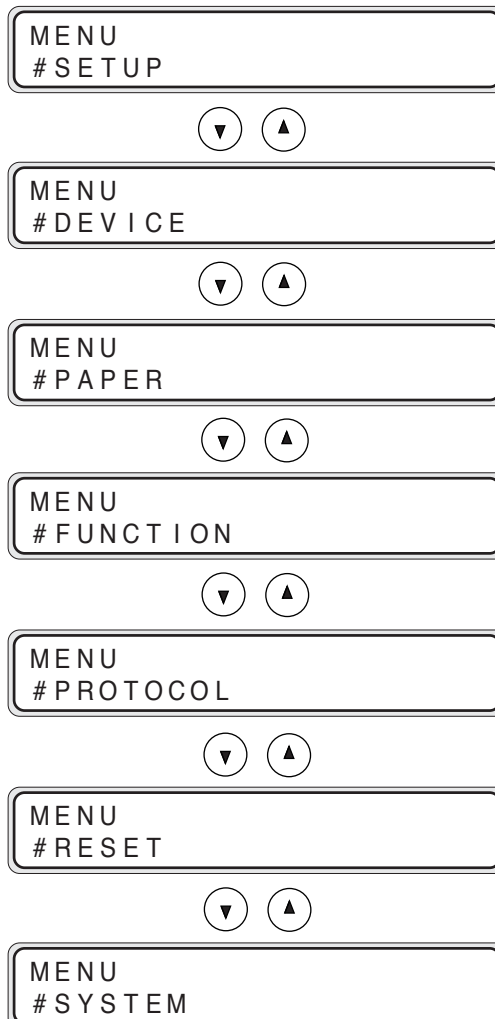

Printing status

MENU
SETUP



MENU
DEVICE



MENU
PAPER



MENU
PROTOCOL







MENU
RESET



MENU
SYSTEM

Menu screen

When the device is online and you press the  key to go offline, a menu screen appears. Select a menu using the ,  keys and press the  key to enter each menu.

Setup menu “SETUP”

Press the  key on the display indicated below to enter the Setup menu.

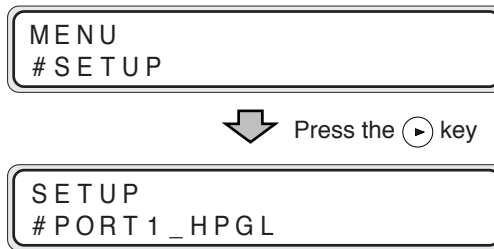

Perform PDL parameter settings.



For PDL parameter settings, set printing mode etc. The Setup menu also contains the following items.

Menu	Item	Functions
Setup	PORT n_HPGL	Sets the PDL table parameter settings for Ethernet port n. Performs the settings relating to HPGL format printing.
	PORT n_DSCAN	Sets the PDL table parameter settings for Ethernet port n. Performs the settings relating to DSCAN format printing.
	PORT n_TIFF	Sets PDL table parameter settings for Ethernet port n. Perform the settings relating to TIFF format printing.
	PORT n_CALS	Sets PDL table parameter settings for Ethernet port n. Performs the settings relating to CALS format printing.

Device menu “DEVICE”

From the display indicated below, press the  key to enter the Device menu.

MENU
DEVICE

 Press the  key.

POWER SAVE
> 15 min



Menu	Item	Functions
Device	POWER SAVE	Sets the time until the device enters the power saving mode.
	EDGE CUT TIMER	Sets the data standby time to automatically have the paper roll end cut before plotting using data received after a Data standby status has continued for a while.
	DOOR OPEN CUT	To plot the first data after the roll door is opened and closed, sets whether to start plotting after the end of the roll paper is automatically cut.
	DENSITY	Adjusts the printing density.
	TRACING PAP. MODE	Sets the tracing paper printing mode.
	BOTTLE MAINT.	Sets whether the maintenance of waste toner bottle starts automatically or manually.

Paper menu “PAPER”

Press the  key while the display below is appearing to enter the Paper menu.



MENU
PAPER

 Press the  key.





PAPER
ROLL 1

In this menu, you can specify the paper type and series.

Function menu "FUNCTION"

Press the  key on the display below to enter the Function menu.

MENU
#FUNCTION

 Press the  key.



#MENU PRINT
>SYSTEM

Menu	Item	Function
Function	MENU PRINT	Prints the status of consumables, device information, and panel settings.
	HPGL SELF PLOT	Outputs the drawing for the data format (HPGL) built in this device.
	DSCAN SELF PLOT	Outputs the drawing for the data format (DSCAN) built in this device.
	ERROR LOG	Prints error log information.
	JOB LOG	Prints job log information.
	ENGINE LOG	Prints detailed information for the engine.
	SYSTEM DATE	Sets the date (year, month, day).
	SYSTEM TIME	Sets the time (hour, minutes, seconds).
	INIT CHARG. INF	Initializes accounting information.
	PRINT CHARG. INF	Prints accounting information.
	MAINT. INFO	Prints maintenance information.
DATA DUMP	Outputs a portion of the plotting data in hexadecimal digit onto paper.	

Protocol menu "PROTOCOL"

Press the  key on the display below to enter the Protocol menu.

MENU
PROTOCOL

 Press the  key.

PROTOCOL
PORT 1 : XPT

After changing these settings, the system will reset.

Menu	Item	Function
Protocol	PORTn : xxx	The Ethernet port PDL selection and protocol name are set here. N indicates the port number, xxx indicates the Ethernet protocol type. Up to 10 ports may be specified. To set the protocol name, XPT sets the XPT port, LPD sets the printer name, and FTP sets the user name.
	PARALLEL	Performs the PDL selection for the parallel channel.

Reset menu “RESET”

Press the  key on the display below to enter the Reset menu.

MENU
RESET



Press the  key.



SYSTEM RESET
>

Menu	Item	Function
Reset	SYSTEM RESET	System reset Initializes the device to the same status as when the device power is turned on.
	PORT RESET	Ethernet port reset Resets the communication for the selected logical port.

System menu “SYSTEM”

Press the  key on the display below to enter the System menu.



 Press the  key.



The system will be reset after these changes are made.

Menu	Item	Function
System	COMM. PARAM	Sets the communication parameters.
	WEB LOCK	Sets whether to allow setup privileges from the web browser to User administrator and above.
	ENABLE SERIES	Sets the media series to be used in this device.
	APPLY ROLL	Sets the roll sizes for each media series you use in this device.
	CHINA SIZE	Sets the roll sizes to be used in China in this device.
	INITIAL SET	Sets all parameter settings to their initial values.
	LANGUAGE	Switches the language on the LCD message display.
	LENGTH UNITS	Switches the length unit (millimeter or inch).
	ADMIN PASSWORD	Specifies the administrator password. This password prevents the settings of the plotter from being changed.

Chapter 4

Basic Menu Operation

Chapter 4 provides the basic operating information that you set up each menu.

Contents of this chapter

Summary of basic menu operation

Offline menu operation

Summary of basic menu operation

To enter each menu, operate the respective keys as shown below:

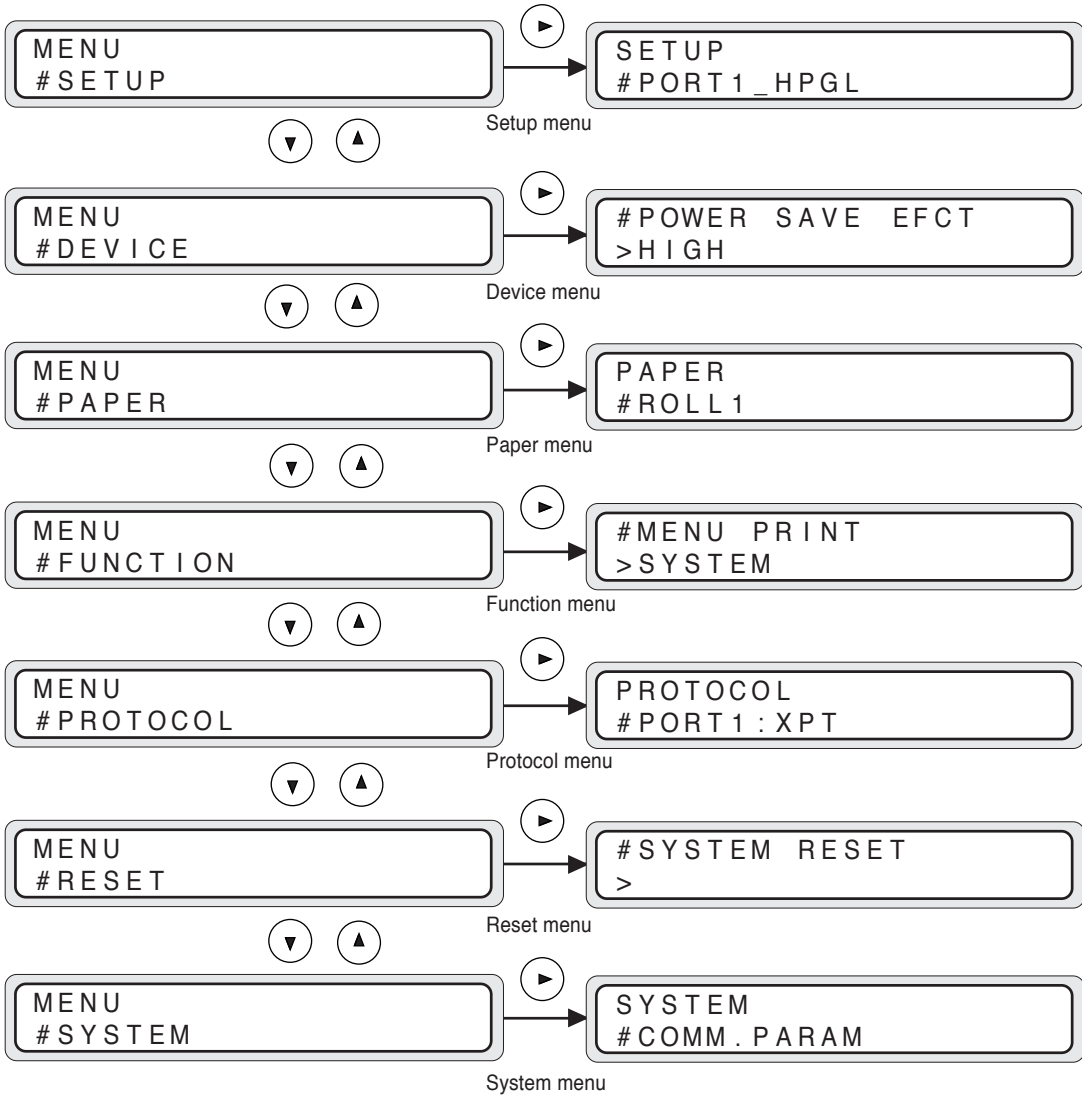

Offline menu operation

Press the  key to enter the offline mode.



If data remains, some menus may not be displayed though key operation is available.

Select the menu group using the  and  keys.

To enter each menu, press the  key.

If any disabled key is pressed, a buzzer sounds.

Switching the menu on the same hierarchy

Press the  or  key to switch the menu within the same hierarchy.

An example of the setup menu group is shown below:

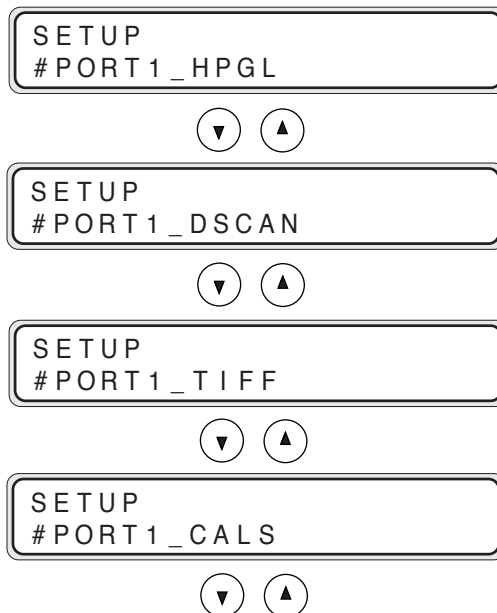

Moving the menu hierarchy



You can move through the menu hierarchy using the  or  key.



An example of the setup menu group is shown below:



Setting or changing the parameters

Press the  key to change the parameters.

Press the  or  key to select a parameter.

Shift the digits of a numerical value or character to enter a desired one using the  and  keys.

Press the  key to select the parameter.

In some menus, the  key is used to execute the respective functions.

Use the  key to cancel the parameter entered.



(Cancellation of setting)

■Choose input method

```
# AUTO SUPPLY
>CONT MODE
```

1 Press the  key to get ready for input.

```
# AUTO SUPPLY
*CONT MODE
```

2 Change the parameters using the  (or ) key.

```
# AUTO SUPPLY
*OPTIMAL MODE
```



3 Select the input using the  key.

```
# AUTO SUPPLY
>OPTIMAL MODE
```

Cancel the change using the  key.



```
# AUTO SUPPLY
>CONT MODE
```

■ Numerical value input method



Shift the digits of a numerical value to enter a desired value using the  and  keys.

1 Press the  key to get ready for input.





```
# IP ADDRESS
*020. 005. 070. 100
```

2 Shift the numeral value digits using the  key (or  key).

```
# IP ADDRESS
*020. 005. 070. 100
```

3 Change the numerical value using the  key (or  key).

```
# IP ADDRESS
*010. 005. 070. 100
```

4 Change the parameter using the , ,  and  keys.

```
# IP ADDRESS
*010. 005. 067. 251
```

5 Select the new value using the  key.

```
# IP ADDRESS
>010. 005. 067. 251
```

Press the  key to cancel the change.



```
# IP ADDRESS
>020. 005. 070. 100
```

■Character input method



Shift the digits of the characters using  and  keys.

1 Press the  key to get ready for input.





```
# USER NAME
* ETP03
```

2 Shift the characters, digits using the  key (or  key).

```
# USER NAME
* FTP03
```

3 Change the characters using the  key (or  key).

```
# USER NAME
* FSP03
```

4 Change the parameter using the , ,  and  keys.

```
# USER NAME
* USER1
```

5 Select the new characters using the  key.

```
# USER NAME
> USER1
```

Press the  key to cancel the change.



```
# USER NAME
> FTP03
```

■ Execution method

```
#ENGINE LOG
>
```

1 Press the  key to get ready for input

```
#ENGINE LOG
*                               OK?
```

2 Execute using the  key (or return to exit display without execution using the  key).

```
LOCAL PRINT      01 / 01
```



After completion of execution, display before the execution appears.

■Choice execution method



```
#MENU PRINT  
>SYSTEM
```

1 Press the  key to get ready for input.

```
#MENU PRINT  
*SYSTEM OK?
```

2 Select a parameter using the  key (or  key).

```
#MENU PRINT  
*PORT 1 OK?
```

3 Execute using the  key (or return to exit display without execution using the  key).

```
LOCAL PRINT 01/01
```

After completing execution, display before execution appears.

Exiting the setting

Press the  key to return to the online condition.

Chapter 5

"SETUP" Menu

Chapter 5 explains how to set the print parameters.

Contents of this chapter

Setting parameter items

Setting parameter items

The following print parameters can be set.

```
SET UP
#PORT1_HPGL
```

Setting PDL parameters and device parameters can be set.

- PARAMETER MODE (DSCAN only)
- MEDIA SERIES (8HP-GL, TIFF, CALS only)
- AUTO SUPPLY
- FIXSIZE MODE
- COPY COUNT
- SUPPLY PARAM.
- DRAWING PARAM.
- SCALING PARAM.
- FORMAT PARAM.(HP-GL, DSCAN only)
- PEN PARAMETER (HP-GL, DSCAN only)
- RASTER PARAM.

Though the setup menu can be referred to or changed during the printing process, the changed parameters are effective from the next job.

The changed parameters are automatically saved after the completion of the setup operation, but the parameters that were only referred to are not saved.

Setting parameters in the setup menu are tabulated below and each parameter is explained. Most of setting parameters as well as those of PDL are common. Parameters which are not displayed by PDL or those of different display are defined each time.

e.g. DSCAN only, etc.

Setup menu setting parameter table

Menu	First hierarchy item	Second hierarchy item
SETUP	SETUP #PORT n_HPGL	Refer to (A) ^{Note 1)}
	SETUP #PORT n_DSCAN	
	SETUP #PORT n_TIFF	
	SETUP #PORT n_CALS	
	SETUP #PARA_HPGL	Refer to (A)
	SETUP #PARA_DSCAN	
	SETUP #PARA_TIFF	
	SETUP #PARA_CALS	
	SETUP #USB_HPGL	

^{Note 1)} Disabled ports will not be indicated. (refer to PORT select in the system menu.)
 Only the PDL selected via PDL select is displayed. (refer to PDL select in the Protocol menu.)
 Parallel and USB will be indicated only when the respective interfaces are installed.

(A)

Second hierarchy item	Third hierarchy item name	Parameter	Remarks
PARAMETER MODE	-	DATA FIRST, PANEL FIRST	DSCAN only
MEDIA SERIES	-	A SERIES 9" SERIES 8.5" SERIES 30×42 SERIES MAP SERIES DIN SERIES CHINA SERIES	HP-GL, TIFF, CALS only
AUTO SUPPLY	-	CONT MODE OPTIMAL MODE ROLL 1 MODE ROLL 2 MODE MANUAL FEED	
FIXSIZE MODE	-	FIXED SIZE EXTENSION A FIXED SIZE REAL SCALE	DSCAN displays the FIXED SIZE as A FIXED SIZE.
COPY COUNT	-	1 to 99 (Initial value=1)	
SUPPLY PARAM.	refer (B)	-	
DRAWING PARAM.	refer (C)	-	
SCALING PARAM.	refer (D)	-	
FORMAT PARAM.	refer (E)	-	HP-GL, DSCAN only
PEN PARAMETER	refer (F)	-	HP-GL, DSCAN only
RASTER PARAM	refer (G)	-	

* Parameter mode is displayed for DSCAN only.

Format parameter and pen parameter are displayed for HP-GL and DSCAN only.

(B)

Third hierarchy item	Parameter	Remarks
CENTERING	OFF ON	
PAPER TYPE	NON-DESIGNATED NORMAL PAPER TRACING PAPER FILM	
SIZE MARGIN (mm)	0 to 30 (Initial value = 2)	
SIZE MARGIN (in)	0 to 1.1 inches (Initial value = 0.08)	

(C)

Third hierarchy item	Parameter	Remarks
OFFSET MODE	MARGIN VARIABLE SIZE FIXED SIZE	
MARGIN (mm)	0 to 100 (Initial value=0)	
MARGIN (in)	0 to 3.9 inches (Initial value=0)	
X-OFFSET (mm)	-9999.99 to +9999.99 (Initial value=0)	
X-OFFSET (in)	-393.700 to +393.700 inches (Initial value=0)	
Y-OFFSET (mm)	-9999.99 to +9999.99 (Initial value=0)	
Y-OFFSET (in)	-393.700 to +393.700 inches (Initial value=0)	
WRITE MODE	OR WRITING OVER WRITING	
MIRROR	OFF ON	
REVERSE	OFF ON	TIFF, CALS only
ERROR MEMO	ON SPECIAL OFF	SPECIAL for HP-GL only
PlotDataToFile	OFF ON+Print	

(D)

Third hierarchy item	Parameter	Remarks
SCALE MODE	MANUAL SCALE REDUCE	
SCALE X (%)	0.01 to 1000.00 (Initial value=100.00)	Enabled when scale mode = manual scale.
SCALE Y (%)	0.01 to 1000.00 (Initial value=100.00)	Enabled when scale mode = manual scale.
PEN WIDTH SCALE	ON OFF	
FIX SCALE A	(D-1)	
FIX SCALE 9"	(D-2)	HP-GL, TIFF, CALS only
FIX SCALE 8.5"	(D-3)	HP-GL, TIFF, CALS only

(D-1)

Fourth hierarchy item	Parameter	Remarks
A4	A4 A3 A2 A1 A0	Enabled when scale mode = manual scale.
A3	A3 A2 A1 A0 A4	Enabled when scale mode = manual scale.
A2	A2 A1 A0 A4 A3	Enabled when scale mode = manual scale.
A1	A1 A0 A4 A3 A2	Enabled when scale mode = manual scale.
A0	A0 A4 A3 A2 A1	Enabled when scale mode = manual scale.

(D-2)

Fourth hierarchy item	Parameter	Remarks
A	A B C D E	Enabled when scale mode = manual scale.
B	B C D E A	Enabled when scale mode = manual scale.
C	C D E A B	Enabled when scale mode = manual scale.
D	D E A B C	Enabled when scale mode = manual scale.
E	E A B C D	Enabled when scale mode = manual scale.

(D-3)

Fourth hierarchy item	Parameter	Remarks
A	A B C D E	Enabled when scale mode = manual scale.
B	B C D E A	Enabled when scale mode = manual scale.
C	C D E A B	Enabled when scale mode = manual scale.
D	D E A B C	Enabled when scale mode = manual scale.
E	E A B C D	Enabled when scale mode = manual scale.

(E)

Third hierarchy item	Parameter	Remarks
PRT DRIVER	ENABLE DISABLE CHINA	HP-GL only
GRAPHIC LANG.	AUTO HP-GL HP-GL/2	HP-GL only
TERMINATOR PG1;	ON OFF	HP-GL only
TERMINATOR NR;	ON OFF	HP-GL only
TERMINATOR SP0;	ON OFF	HP-GL only
TERMINATOR ESC.)	ON OFF	HP-GL only
TERMINATOR AF;	ON OFF	HP-GL only
TERMINATOR AH;	ON OFF	HP-GL only
TERMINATOR FR;	ON OFF	HP-GL only
PLAN SIZE	ON (PS) ON (IP) ON (IW) OFF	HP-GL only
DRAWING	NOP EOP	DSCAN only
PAPER NO.	PAPER SOURCE PAPER TYPE OFF	DSCAN only

(F)

Third hierarchy item	Parameter	Remarks
PEN PAR. MODE	DATA PRIORITY PANEL PRIORITY	
PEN N WIDTH (mm)	0.00 to 16.00 (Initial value) PEN 0 : 0.2 PEN 1 : 0.3 PEN 2 : 0.4 PEN 3 : 0.5 PEN 4 : 0.6 PEN 5 : 0.7 PEN 6 : 0.8 PEN 7 : 0.9 PEN 8 and later : 1.0	Pen 8 and later: 10 Set HP-GL to pen 0 to 15. 0.00 is 1-dot width. Set DSCAN to pen 1 to 32.
PEN N WIDTH (in)	0 to 0.629 inches (Initial value) PEN 0 : 0.008 inches PEN 1 : 0.012 inches PEN 2 : 0.016 inches PEN 3 : 0.020 inches PEN 4 : 0.024 inches PEN 5 : 0.028 inches PEN 6 : 0.031 inches PEN 7 : 0.035 inches PEN 8 and later: 0.039 inches	Pen 8 and later: 10 Set HP-GL to pen 0 to 15. 0.00 is 1-dot width. Set DSCAN to pen 1 to 32.
PEN DENSITY (%)	0 to 100 (Initial value) Pen 0 : 0 Pen 1 and later : 100	Set HP-GL to pen 0 to 15. Set DSCAN to pen 1 to 32.
PEN N CORNER	ROUND BUTT	Set HP-GL to pen 0 to 15. Set DSCAN to pen 1 to 32.
PEN N JOINT	ROUND MITERED	Set HP-GL to pen 0 to 15. Set DSCAN to pen 1 to 32.
PEN ADJUST (mm)	-0.99 to +0.99 (Initial value = 0.00)	
PEN ADJUST (in)	-0.038 to +0.038 inches (Initial value = 0.00)	
LINE DISPOSAL	OFF ON	

(G)

Third hierarchy item	Parameter	Remarks
IMAGE SCALE	LINE DRAW. MODE PICTURE MODE	
SCREENING	LINE DRAW. MODE GRAPHICS MODE PICTURE MODE	HP-GL, DSCAN, TIFF only

Setup parameter priority mode

HP-GL PDL and D-SCAN PDL allow for selecting the setup parameter priority mode (DATA FIRST/PANEL FIRST). Even if the DATA FIRST mode is specified, the settings preset in this printer are used for the parameters to which no data has been specified.

Setting items to be affected by parameter mode (D-SCAN only)

COPY COUNT
FIXSIZE MODE
WRITE MODE
MIRROR
DRAWING
PAPER NO.

Setting items to be affected by PEN PAR. MODE

PEN _n WIDTH
PEN _n DENSITY
PEN _n CORNER ^{Note)}
PEN _n JOINT ^{Note)}

Note: Equipment setting is always enabled in the D-SCAN PDL.

When a printer driver HP-GL PDL is used and the printer driver setting is disabled (PRT DRIVER = DISABLE), setting of this device is enabled without using the setting on the printer driver screen of the computer.

PARAMETER MODE (DSCAN only)

Allows for determining which setting is enabled for parameters which can be set both with data or on the panel.

This setting is performed on the second hierarchy.

Note

- ◆ The DSCAN format is for only customers in Japan.

<Parameter (choice input method)> : Default value

DATA FIRST Enables the setting with data.

PANEL FIRST Enables the setting on the panel.

MEDIA SERIES (HP-GL, TIFF, CALS only)

When the paper feed mode is set to CONT MODE, OPTIMAL MODE, or MANUAL FEED mode, set the series of paper to be fed. This setting is performed on the second hierarchy.

<Parameter (choice input method)> : Default value

A SERIES Allows for A series automatic feeding.

9" SERIES Allows for 9×12 inch series automatic feeding.

8.5" SERIES Allows for 8.5×11 inch series automatic feeding.

30×42 SERIES Allows for 30×42 inch series automatic feeding.

MAP SERIES Allows for MAP series automatic feeding.

DIN SERIES Allows for DIN series automatic feeding.

CHINA SERIES Allows for China series automatic feeding.

Note

- ◆ Default values are changed in the item INITIAL SET item.

AUTO SUPPLY

Allows for setting the paper feeding conditions.

This setting is performed on the second hierarchy.

<Parameter (choice input method)> : Default value

<input type="checkbox"/> CONT MODE	When plots can be produced without clipping the drawing, the plots are continuously produced (Small rolls only).
<input type="checkbox"/> OPTIMAL MODE	An optimum roll is used for plotting to minimize wasted media. If the optimum roll is not loaded, the printing process is suspended and replacement of paper is demanded.
<input type="checkbox"/> ROLL 1 MODE	Prints on roll 1 paper.
<input type="checkbox"/> ROLL 2 MODE	Prints on roll 2 paper.
<input type="checkbox"/> MANUAL FEED	Prints on the paper fed by hand.

Note

- ◆ The default value varies depending on the setting in the INITIAL SETTING.

FIXING MODE

Fixed sizes supported by this device are listed below:

A series	Long side	Short side
A0 size	1189.0 mm (46.8 inches)	841.0 mm (33.1 inches)
A1 size	841.0 mm (33.1 inches)	594.5 mm (23.4 inches)
A2 size	594.5 mm (23.4 inches)	420.5 mm (16.6 inches)
A3 size	420.5 mm (16.6 inches)	297.3 mm (11.7 inches)
A4 size	297.3 mm (11.7 inches)	210.3 mm (8.3 inches)

9x 12 series	Long side	Short side
E size	1219.2 mm (48 inches)	914.4 mm (36 inches)
D size	914.4 mm (36 inches)	609.6 mm (24 inches)
C size	609.6 mm (24 inches)	457.2 mm (18 inches)
B size	457.2 mm (18 inches)	304.8 mm (12 inches)
A size	304.8 mm (12 inches)	228.6 mm (9 inches)

8.5x 11 series	Long side	Short side
E size	1117.6 mm (44 inches)	863.6 mm (34 inches)
D size	863.6 mm (34 inches)	558.8 mm (22inches)
C size	558.8 mm (22inches)	431.8 mm (17 inches)
B size	431.8 mm (17 inches)	279.4 mm (11 inches)
A size	279.4 mm (11 inches)	215.9 mm (8.5 inches)

30x 42 series	Long side	Short side
30x 42 size	1066.8 mm (42 inches)	762.0 mm (30 inches)

MAP series	Long side	Short side
B1 size	1000.0 mm (39.4 inches)	700.0 mm (27.6 inches)
B2 size	700.0 mm (27.6 inches)	500.0 mm (19.7 inches)

DIN series	Long side	Short side
B1 size	1000.0 mm (39.4 inches)	707.0 mm (27.8 inches)
B2 size	707.0 mm (27.8 inches)	500.0 mm (19.7 inches)
B3 size	500.0 mm (19.7 inches)	353.0 mm (13.9 inches)

<Parameter (choice input method)> : Default value*

FIX SIZE	Produces fixed form of plots.
EXTENSION A	In addition to the fixed size of A1 to A4, sizes extended from the fixed size by 0.5 in vertical direction (1.5A3, 2A2, etc.) are also handled as the fixed form. When plotting on paper other than the A series, use the fixed form plotting procedure.
REAL SCALE	Prints at actual length.

Notes

- ◆ The default value varies depending on the setting in the INITIAL SETTING.
- ◆ When producing plots on paper of China series, printing is always made at actual length.
- ◆ DSCAN displays FIX as A SERIES.

COPY COUNT

Allows for choosing of the number of copies.

When the number of copies is set with the HP-GL data, setting of the data is used.

This setting is performed on the second hierarchy.

<Parameter (numerical value input method)>

1 to 99 (No. of sheets) Default value=1

SUPPLY PARAM.

■CENTERING

Aligns a drawing to the center of the paper. (See the figure below.)
 This setting is found on the third hierarchy.

<Parameter (choice input method)> : Default value

OFF Centering is not performed.

ON Centering is performed.

For the data which cannot be completely saved in the spool memory, centering is not available.

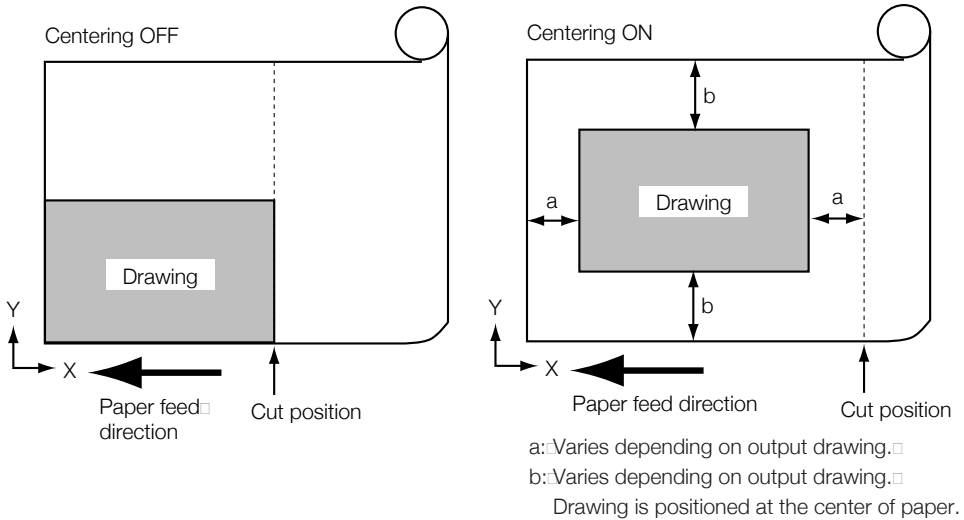

■PAPER TYPE

Allows for setting of the type of paper to be used in the paper feed mode = continuous mode or optimum mode. This setting is found on the second hierarchy.

<Parameter (choice input method)> : Default value

NON-DESIGNATED Paper type is not specified.

NORMAL PAPER Allows for normal paper feeding.

TRACING PAPER Allows for tracing paper feeding.

FILM Allows for film feeding.

■SIZE MARGIN (mm) / SIZE MARGIN (in)

Allows for setting of the margin to be used or extended fixed form paper is used when these settings also apply a plot is produced on paper size in the actual length. The paper size of the fixed size or paper roll size is judged as being larger by the value preset for the size margin. However, the area where plotting can be performed actually is the original paper size, and thus the drawing area beyond the original paper size is clipped.

<Parameter (numerical value input method)>

0 to 30 (0 to 1.1 inches)

Default value = 2 (0.08 inches)

DRAWING PARAM.

This is a parameter group that you need to set plotting conditions.

■OFFSET MODE

Allows for setting which offset function is used from among MARGIN/VARIABLE SIZE OFFSET/FIXED SIZE OFFSET. This setting is performed on the third hierarchy.

<Parameter (choice input method)> : Default value

<input checked="" type="checkbox"/> MARGIN	MARGIN is used as the offset function. Setting of MARGIN is enabled.
<input type="checkbox"/> VARIABLE SIZE	Offset X and Y are used as the offset function. Offset X and Y setting is enabled. Drawing size increases or decreases depending on the offset value.
<input type="checkbox"/> FIXED SIZE	Offset X and Y are used as the offset function. Offset X and Y setting is enabled. As the drawing size does not vary depending on the offset, data may be clipped. If the drawing size is not set to the data, offset is performed in the VARIABLE SIZE mode.

■ MARGIN (mm) / MARGIN (in)

Allows for setting of the margin size to be added to the circumference of drawing actual length. This setting is enabled at the time of OFFSET MODE = MARGIN setting. This setting is performed on the third hierarchy.

<Parameter (numerical value input method)>

0 to 100 (0 to 3.9 inches) Default value = 0

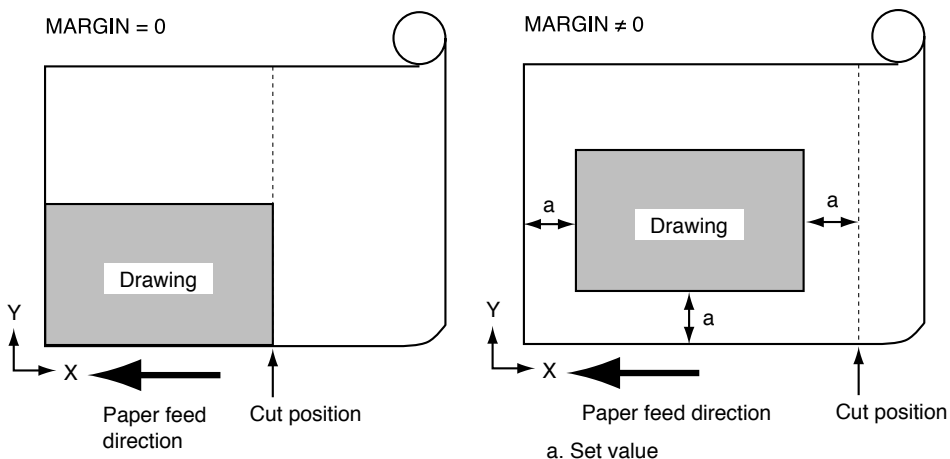

■ X-OFFSET (mm) / X-OFFSET (in)

Y-OFFSET (mm) / Y-OFFSET (in)

Allows for setting the offset X and Y. This setting is enabled at the time of OFFSET MODE = VARIABLE SIZE or FIXED SIZE setting. This setting is disabled when CENTERING = ON setting.

This setting is disabled when the drawing being produced at the center of the origin coordinates is produced in the PAGE SIZE = REAL SCALE for the HP-GL data only. This setting is performed on the third hierarchy.

<Parameter (numerical value input method)>

-9999.99 to 9999.99 (-393.700 to +393.700 inches) Default value = 0

■WRITE MODE

Allows for setting of the drawing overlap method. When the HP-GL data is used for setting the WRITE MODE, the data setting is enabled. The default setting is "OR WRITING". This setting is changed on the third hierarchy.

<Parameter (choice input method)> : Default value

OR WRITING Drawing is overlapped.

OVER WRITING Drawing is overwritten.

■MIRROR

Allows for setting whether to produce a plot by turning over the plot around the drawing center line in parallel with the X axis (line symmetry).

This setting is performed on the third hierarchy.

<Parameter (choice input method)> : Default value

OFF Mirror plotting is not performed.

ON Mirror plotting is performed.

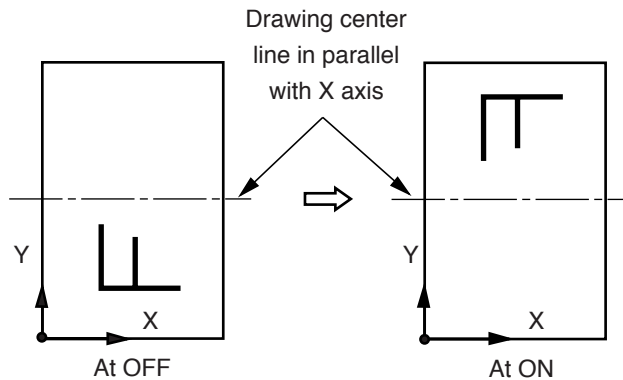

■REVERSE (TIFF, CALS only)

Allows for setting whether reverse plotting (with black and white inverted) is made or not. This setting is performed on the third hierarchy.

<Parameter (choice input method)> : Default value

OFF Reverse plotting is not performed.

ON Reverse plotting is performed.

■ERROR MEMO

Allows for setting whether to attach an error memo beside the plotting if a command error or other PDL error occurs. This setting is performed on the third hierarchy.

<Parameter (choice input method)> : Default value

ON If a PDL error occurs during data processing, an error memo is attached to the side of the drawing while it is being printed.

SPECIAL If an PDL error occurs during data processing, an error memo is attached to the side of the drawing while it is being printed. For the command error only, the error memo is not printed. (HP-GL only)

OFF Error memo is not attached.

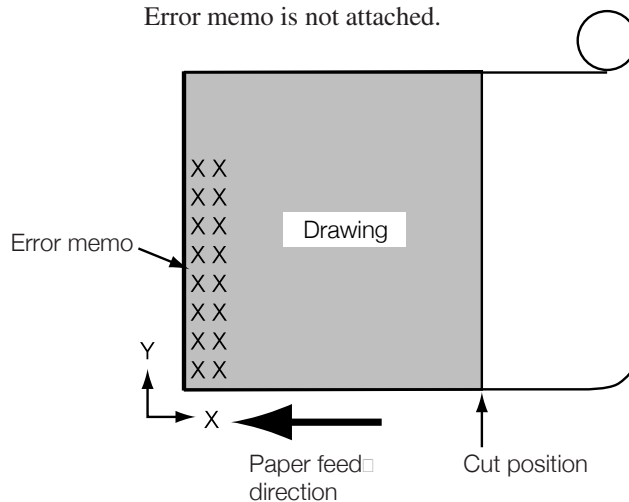

■PlotDataToFile

Since this setting is only for Japan, leave the setting as it is.

SCALING PARAM.

This is a parameter group that allows you to set scale conditions.

■SCALE MODE

Allows for setting whether to apply the scale to the drawing manually or allow the automatic reduction.

When the manual scale is selected, the scale is applied to the drawing according to the setting of scale X, scale Y and scale FIX.

This setting is performed on the third hierarchy.

<Parameter (choice input method)> : Default value

MANUAL SCALE Automatic scaling does not take place. Manual scale parameters (scale X and Y and fix scale) are enabled.

REDUCE Drawing is automatically reduced to be within the paper size.

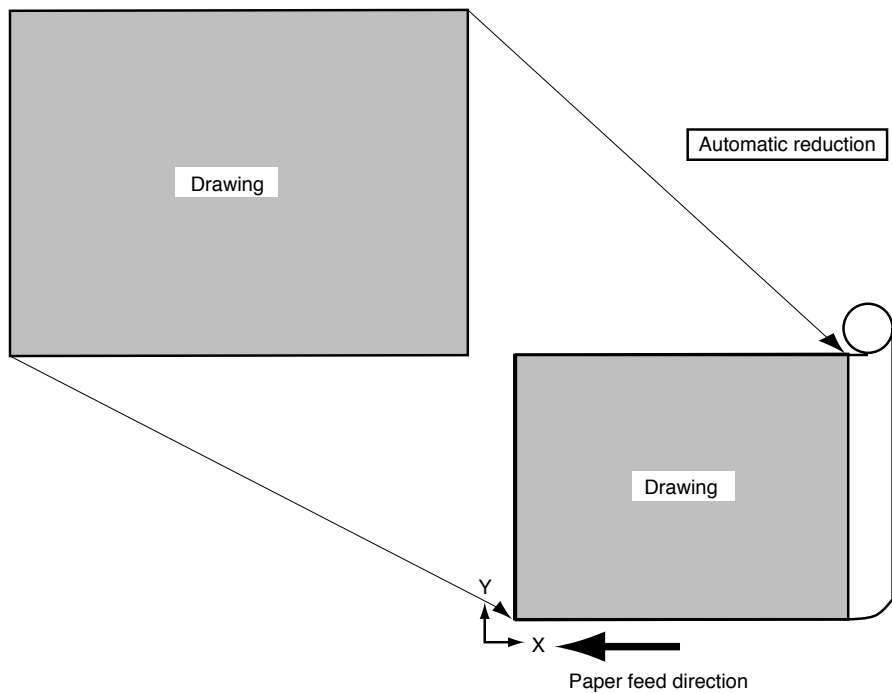

■ SCALE X (%)
SCALE Y (%)

When setting "SCALE MODE = MANUAL SCALE," values of the scale applied to X and Y directions of the drawing are set up. This setting is performed on the third hierarchy.

<Parameter (numerical value input method)>

0.01 to 1000.00 Default value = 100

This setting is enabled when setting "SCALE MODE = MANUAL SCALE." When it is set to 100%, the plot is produced in 1-to-1 magnification.

■ PEN WIDTH SCALE (HP-GL, DSCAN only)

Sets the scaling down method, when the drawing is scaled down (in the same X and Y proportion). This setting is performed on the third hierarchy.

<Parameter (choice input method)> : Default value

- ON Line width or interval between points are also scaled down. Maximum line width is 16 mm (0.63 inches).
- OFF Line width or interval between points are not scaled down.

■ FIX SCALE A

- FIX SCALE 9"
FIX SCALE 8.5"

Allows for setting the method of automatic scale from one fixed form to another when setting "SCALE MODE = MANUAL SCALE." This setting is disabled when plotting in the actual length or expanded fixed form. This setting is performed on the third hierarchy.

<Parameter (choice input method)>

FIX SCALE A

- Automatically scaled to A4 fix size.
- Automatically scaled to A3 fix size.
- Automatically scaled to A2 fix size.
- Automatically scaled to A1 fix size.
- Automatically scaled to A0 fix size.

FIX SCALE 9"

- A Automatically scaled to 9×12 inch series A fix size.
- B Automatically scaled to 9×12 inch series B fix size.
- C Automatically scaled to 9×12 inch series C fix size.
- D Automatically scaled to 9×12 inch series D fix size.
- E Automatically scaled to 9×12 inch series E fix size.

FIX SCALE 8.5"

- A Automatically scaled to 8.5 × 11 inch series A fix size.
- B Automatically scaled to 8.5 × 11 inch series B fix size.
- C Automatically scaled to 8.5 × 11 inch series C fix size.
- D Automatically scaled to 8.5 × 11 inch series D fix size.
- E Automatically scaled to 8.5 × 11 inch series E fix size.

FORMAT PARAM. (HP-GL DSCAN only)

These are parameters that you need to set the HP-GL format and DSCAN format analysis conditions.

■ PRT DRIVER (HP-GL only)

Allows for choosing whether or not to use the printer driver. When the printer driver is operated together with another driver, this setting should be ENABLE. Even when the printer driver for LP-1020 is set to the PANEL FIRST mode, this setting can be set to ENABLE without causing a problem. This setting is performed on the third hierarchy.

<Parameter (choice input method)> : Default value

<u>ENABLE</u>	Choose this parameter when using the supplied printer driver for LP-1020. In this case, the setup you made with the panel may not be used for operation. When data is received from a driver other than the printer driver for LP-1020 in this setting, setup for this device is enabled.
DISABLE	When the printer driver is operated in the PANEL SETUP using the printer driver for LP-1020, this setting should be used.
CHINA	This parameter should be set up when printing the roll of the China series on the printer driver for LP-1020. In this case, the roll can be operated without using the setup. In this setting, the driver output data selects automatically the roll of China series and operation for the actual size plotting becomes possible. When data is received from a driver other than the printer driver for LP-1020, the setup is enabled.

Note

- ◆ The default value varies depending on the setting in the INITIAL SETTING.

■GRAPHIC LANG. (HP-GL only)

Allows to set whether to handle the data received as HP-GL or HP-GL/2. Data handling is done automatically in the AUTO setting. The origin coordinates affected depending on HP-GL or HP-GL/2. This setting is performed on the third hierarchy.

<Parameter (choice input method)> : Default value

<input checked="" type="checkbox"/> AUTO	Judges HP-GL or HP-GL/2 automatically.
<input type="checkbox"/> HP-GL/2	Judges the data received as HOP-GL/2.
<input type="checkbox"/> HP-GL	Judges the data received as HP-GL.

When HP-GL is employed, the origin of coordinates should be the center point. When HP-GL/2 is employed, the origin of coordinates should be the left lower point.

When HP-GL is employed, HP-GL/2 data can be received without causing an error.

■TERMINATOR (HP-GL only)

TERMINATOR PG1;
 TERMINATOR NR;
 TERMINATOR SPO;
 TERMINATOR ESC.)
 TERMINATOR AF;
 TERMINATOR AH;
 TERMINATOR FR;

Allows for setting whether the terminator is to be a condition to complete the drawing for each command. When pen 0 is used as an ordinary pen, set the terminator SP0 to OFF. This setting is performed on the third hierarchy.

<Parameter (choice input method)> : Default value

<input checked="" type="checkbox"/> ON	Sets the command to terminator (EOF).
<input type="checkbox"/> OFF	Does not set the command to terminator (EOF).

■ PLAN SIZE (HP-GL only)

Sets which command is to be enabled as a drawing size command. Sets data to OFF if the drawing size is not properly set. This setting is performed on the third hierarchy.

<Parameter (choice input method)> : Default value

- | | |
|---|--|
| <input checked="" type="checkbox"/> ON (PS) | Sets the PS command as the drawing size. |
| <input type="checkbox"/> ON (IP) | Sets the IP command as the drawing size. |
| <input type="checkbox"/> ON (IW) | Sets the IW command as the drawing size. |
| <input type="checkbox"/> OFF | Disables the drawing size command. |

You need to set ON (IP) and ON (IW) only when it is clear that the IP command or IW command is used as the drawing size, to avoid causing a printing error. (It depends on the CAD application.)

If the PS command is available when setting ON (IP) or ON (IW), the PS command is given priority.

■DRAWING (DSCAN only)

Sets whether or not to plot DRAWING. This setting is performed on the third hierarchy.

<Parameter (choice input method)> : Default value

- NOP** DRAWING Plot is not performed.
- EOF** DRAWING Plot is performed.

■PAPER NO.(DSCAN only)

Allows for setting how to handle the paper type No. When handling the paper type No. as the paper source, paper supply is controlled as listed below.

This setting is performed on the third hierarchy.

<Parameter (choice input method)> : Default value

- PAPER SOURCE/** Handles paper type No. as the paper source.
- PAPER TYPE/** Handles paper type No. as the paper type.
- OFF/** Disables paper type No. of information block.

Manual feed + two-step roll model

Paper type No.	Paper supply control
0	Sets paper type No. = disable. Supplies paper according to the panel paper supply mode setting.
1	Controls paper supply in the paper supply mode = roll 1 mode.
2	Controls paper supply in the paper supply mode = roll 2 mode.
3	Controls paper supply in the paper supply mode = manual feed mode.
4 and above	Controls paper supply in the paper supply mode = roll 1 mode.

When handling paper type No. as a paper supply type, paper supply is controlled as listed below.:

Paper type No.	Paper supply control
0	Sets paper type No. = disable. Supplies paper according to the panel paper supply mode setting.
1	Plot is produced on the normal paper.
2	Plot is produced on the tracing paper.
3	Plot is produced on the film.
4 and above	Sets paper type No. = disable. Supplies paper according to the panel paper supply mode setting.

Note) This setting is meaningless in applications not supporting the paper type No.

PEN PARAMETER (HP-GL DSCAN only)

Allows for setting of the thickness (line width), density and other plotting conditions for the pen of this device. The number of pens is different in HP-GL and DSCAN.

HP-GL: 00 to 15

DSCAN: 01 to 32

■PEN PAR. MODE

Allows for setting the pen attributes by enabling either DATA or PANEL setting. This setting is performed on the third hierarchy.

<Parameter (choice input method)> : Default value

DATA PRIORITY Pen attributes enable DATA setting.

PANEL PRIORITY Pen attributes enable PANEL setting.

■PEN N WIDTH (mm) / PEN N WIDTH (in)

Allows for setting of the width of the pen of this device. If the setting value is 0.00, plot is produced in 1-dot width.

This setting is performed on the third hierarchy.

<Parameter (numerical value input method)>

0.00 to 16.00 (0.00 to 0.629 inches) Default value = 100 (3.94 inches)

PEN 0=0.20 mm (0.008 inches)* * HP-GL only

PEN 1=0.30 mm (0.012 inches) PEN 2=0.40 mm (0.016 inches)

PEN 3=0.50 mm (0.020 inches) PEN 4=0.60 mm (0.024 inches)

PEN 5=0.70 mm (0.028 inches) PEN 6=0.80 mm (0.031 inches)

PEN 7=0.90 mm (0.035 inches) PEN 8=1.00 mm (0.039 inches)

PEN 9=1.00 mm (0.039 inches)

to

PEN 15=1.00 mm (0.039 inches) * In case of HP-GL

PEN 32=1.00 mm (0.039 inches) * In case of DSCAN

Specified value (mm (inch))	No. of dots	Specified value (mm (inch))	No. of dots
0.00 to 0.06 (0.00 to 0.0024)	1	0.53 to 0.57 (0.0209 to 0.0224)	13
0.07 to 0.10 (0.0028 to 0.0039)	2	0.58 to 0.61 (0.0228 to 0.024)	14
0.11 to 0.14 (0.0043 to 0.0055)	3	0.62 to 0.65 (0.0244 to 0.0256)	15
0.15 to 0.19 (0.0059 to 0.0075)	4	0.66 to 0.69 (0.026 to 0.0272)	16
0.20 to 0.23 (0.0079 to 0.0091)	5	0.70 to 0.74 (0.0276 to 0.0291)	17
0.24 to 0.27 (0.0094 to 0.0106)	6	0.75 to 0.78 (0.0295 to 0.0307)	18
0.28 to 0.31 (0.011 to 0.0122)	7	0.79 to 0.82 (0.0311 to 0.0323)	19
0.32 to 0.35 (0.0126 to 0.0138)	8	0.83 to 0.86 (0.0327 to 0.0339)	20
0.36 to 0.40 (0.0028 to 0.0039)	9	0.87 to 0.91 (0.0343 to 0.0358)	21
0.41 to 0.44 (0.0142 to 0.0173)	10	0.92 to 0.95 (0.0362 to 0.0374)	22
0.45 to 0.48 (0.0177 to 0.0189)	11	0.96 to 0.99 (0.0378 to 0.039)	23
0.49 to 0.52 (0.0193 to 0.0205)	12	1.00 to 1.03 (0.0393 to 0.0406)	24

■PEN N DENSITY (%)

Allows to set of the density to the pen of this device.

This setting is performed on the third hierarchy.

<Parameter (numerical value input method)>

0 to 100

Default value:

Pen 0=0, pen 1 to 15 (32) = 100

When the density of thin lines is decreased, plot may be produced in dotted lines.

With the DSCAN format, plot is produced in 16 gradations.

Specified value (%)	Gradation	Specified value (%)	Gradation
0 to 5	1	50 to 56	9
6 to 12	2	57 to 62	10
13 to 18	3	63 to 68	11
19 to 24	4	69 to 74	12
25 to 30	5	75 to 81	13
31 to 37	6	82 to 87	14
38 to 43	7	88 to 93	15
44 to 49	8	94 to 100	16

- In the HP-GL format, density 0% is plotted in white.
- In the DSCAN format, density 0 to 5% is plotted in white.

■PEN N CORNER

Allows for setting of the line end shape of the pen of this device.
This setting is performed on the third hierarchy.

<Parameter (choice input method)> : Default value

ROUND Specifies the line end in a round shape.

BUTT Specifies the line end in a butt shape.

- Line end shape of each parameter is illustrated below.

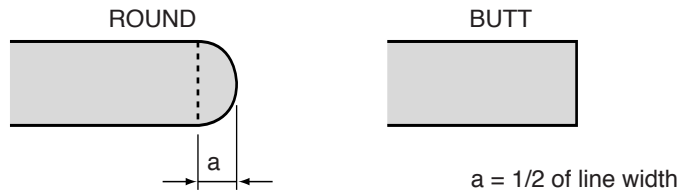

- Any combinations other than CORNER = "ROUND" and JOINT = "ROUND" may take much time for plotting.
- The outermost line of the plot may not be treated for the line end shape.

●PEN N JOINT

Allows for setting the line joint method of the pen of this device.
Setting is performed on the third hierarchy.

<Parameter (choice input method)> : Default value

ROUND Specifies the joint in the round form.

MITERED Specifies the joint in the mitered form.

The joints can be specified with the parameters illustrated below:

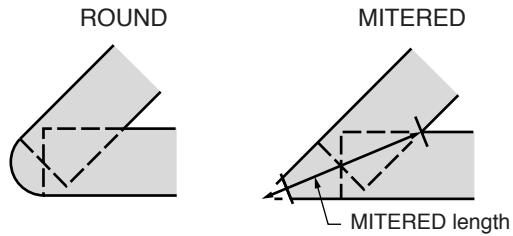

- Any combination other than CORNER = "ROUND" and JOINT = "ROUND" may take long time for plotting.
- Lines not jointed (which are not drawn with one stroke) are excluded.
- If the attributes of lines (line color, line width, line type) change, treatment for joints may not be performed.
- The outermost line of the plot may not be treated for joints.

■PEN ADJUST (mm) / PEN ADJUST (in)

Allows for setting of the pen width adjust value. Plots can be produced with a pen width larger or smaller than the pen width preset with the data or on the panel by the adjust value in the range of the maximum pen width 16 mm (0.63 inches) and minimum width 1 dot.

This setting is performed on the third hierarchy.

<Parameter (numerical value input method)>

-0.99 to +0.99 (-0.038 to +0.038 inches) Default value = 0

■LINE DISPOSAL

Allows for setting of the end shape of fine small lines and their joining method.

<Parameter (choice input method)> : Default value

OFF : Line end shapes other than round one are treated.
 ON : All ends of fine small lines are treated as round shape.

- With this device, lines less than 1mm (0.039 inches) in width and length are handled as micro-length lines.
- Fine small lines may not be clearly plotted in combinations other than CORNER = "ROUND" and JOINT = "ROUND".
By setting the parameter to "ON", the lines are handled as CORNER = "ROUND" and JOINT = "ROUND" allowing clear plotting.

RASTER PARAM

This is a parameter group used to set the raster data plotting conditions.

■ IMAGE SCALE

Set the reduction mode to reduce binary image data. This setting is performed on the third hierarchy.

<Parameter (choice input method)> : Default value

<input type="checkbox"/> LINE DRAW. MODE	Lines are ensured when binary image data is reduced.
<input type="checkbox"/> PICTURE MODE	Density is ensured when binary image data is reduced. (Lines are simply thinned out.)

■ SCREENING (HP-GL, DSCAN, TIFF only)

Specifies the multi-valued image data screening method.
This setting is performed on the third hierarchy.

<Parameter (choice input method)> : Default value

<input type="checkbox"/> LINE DRAW. MODE	Screening appropriate to line drawing is performed for multi-valued image data.
<input type="checkbox"/> GRAPHICS MODE	Screening appropriate to computer graphics is performed for the multi-valued image data.
<input type="checkbox"/> PICTURE MODE	Screening appropriate to pictures is performed for the multi-valued image data. This mode requires a little more time than the GRAPHIC and PICTURE MODES for the treatment.

Chapter 6

"DEVICE" menu

Chapter 6 describes the "DEVICE" menu to specify the operating conditions for the engine of this device.

Contents of this chapter

Setting items

Setting items

Operating conditions are set for the engine of this device in the "Device" menu.

```
# POWER SAVE
> 15 min
```

"Device" menu has a structure as listed below:

Menu	First hierarchy item	Parameter
Device	#POWER SAVE >15 min	15 min 30 min 60 min 90 min 235 min
	#EDGE CUT TIMER >OFF	OFF 30 min 1 hour 2 hour 4 hour 1 min 5 min 10 min
	#DOOR OPEN CUT >OFF	OFF ON
	#DENSITY >NORMAL	THIN RATHER THIN NORMAL RATHER THICK THICK
	#TRACING PAP. MODE >NORMAL	NORMAL WETTY
	#BOTTLE MAINT. >AUTO	AUTO MANUAL

POWER SAVE

Specifies the time until the power saving mode is entered to minimize the power consumption.

<Parameter (choice input method)> : Default value

<input checked="" type="checkbox"/> 15 min	Device enters the power saving mode after being left for 15 minutes.
<input type="checkbox"/> 30 min	Device enters the power saving mode after being left for 30 minutes.
<input type="checkbox"/> 60 min	Device enters the power saving mode after being left for 60 minutes.
<input type="checkbox"/> 90 min	Device enters the power saving mode after being left for 90 minutes.
<input type="checkbox"/> 235 min	Device enters the power saving mode after being left for 235 minutes.

- After completion of plotting, when the preset time for waiting data has elapsed, the device automatically enters the power saving mode.
- When data is received, the power saving mode is automatically reset.
- By pressing the  key, the power saving mode is automatically reset.

EDGE CUT TIMER

When you plot data received after waiting for the data continuously, specify the time waiting for the data so that the paper roll end is automatically cut and the plot is produced.



Tip

- ◆ If plotting is not effected for a long time, the paper roll end may be crumpled or stained by moisture or dust causing blurring or missing of print.

Use this function to avoid such troubles.

<Parameter (choice input method)> : Default value

<input type="checkbox"/> OFF	Does not cut.
<input type="checkbox"/> 30 min	Cuts after the device is left for 30 minutes.
<input type="checkbox"/> 1 hour	Cuts after the device is left for 1 hour.
<input type="checkbox"/> 2 hour	Cuts after the device is left for 2 hours.
<input type="checkbox"/> 4 hour	Cuts after the device is left for 4 hours.
<input type="checkbox"/> 1 min	Cuts after the device is left for 1 minute.
<input type="checkbox"/> 5 min	Cuts after the device is left for 5 minutes.
<input type="checkbox"/> 10 min	Cuts after the device is left for 10 minutes.

- Specifies the time from the completion of previous plotting to the start of plotting of data received this time.
- Cuts about 400 mm (15.7 inches).

DOOR OPEN CUT

Specifies whether the plotting is started or not after the paper roll end is automatically cut, when you plot the first data after opening and closing the roll 1 or roll 2 door. Cutting width is 400 mm (15.7 inches).



- ◆ This function is used to cut the paper roll end using the cutter of this device. Specify this function when you desire to cut the paper end of output drawing cleanly.

<Parameter (choice input method)> : Default value

OFF Not cut.

ON Cut.

DENSITY

Adjusts the printing density.

<Parameter (choice input method)> : Default value

THIN/RATHER THIN/ NORMAL/RATHER THIC/THICK

TRACING PAP. MODE

Specifies the environmental condition for tracing paper.

<Parameter (choice input method)> : Default value

NORMAL When using the print in normal environment.

WETTY When using the print in environment of high humidity.

BOTTLE MAINT.

In order to prevent the waste toner from accumulating unevenly in the waste toner bottle, this device provides the maintenance function that taps the waste toner bottle to level the waste toner when the specified amount of print is executed.

Set whether this maintenance starts automatically or a message to prompt you to perform maintenance is displayed. In the latter case, the maintenance does not start unless the key is pressed.

<Parameter (choice input method)> : Default value

AUTO The maintenance of waste toner bottle starts automatically.

MANUAL The maintenance of waste toner bottle is started manually.

Chapter 7

"PAPER" menu

Chapter 7 describes the "PAPER" menu used to specify the type of paper. Always specify this item according to the type of paper which is installed on this device.

Contents of this chapter

Setting items

Setting items

Allows for setting of the type and series of the paper rolls.

PAPER
#ROLL 1

Menu	Menu / First hierarchy item	Second hierarchy item	Parameter
PAPER	PAPER #ROLLn	#MEDIA TYPE >BOND	BOND TRACING FILM
		#MEDIA SERIES >A SERIES	A SERIES 9" SERIES 8.5" SERIES 30×42 SERIES MAP SERIES DIN SERIES CHINA SERIES

Note) Only choices of MEDIA SERIES which are enabled in the ENABLE SERIES of the system parameters are displayed.

MEDIA TYPE

Allows for setting of the type of paper to be used.

<Parameter (choice input method)> :Default value

<input checked="" type="checkbox"/> BOND	Paper
<input type="checkbox"/> TRACING	Tracing Paper
<input type="checkbox"/> FILM	Mat Film

MEDIA SERIES

The following widths are used in this device.

When a paper roll is loaded into the paper feed unit, the series of the paper specified in this setting should be accordingly.

A SERIES

A0 (841 mm / 33.1 inches), A1 (594.5 mm / 23.4 inches),
A2 (420.5 mm / 16.6 inches), A3 (297.3 mm / 11.7 inches)

9" SERIES

36" (914 mm), 24" (609.6 mm), 18" (457.2 mm), 12" (304.8 mm)

8.5" SERIES

34" (863.6 mm), 22" (558.8 mm), 17" (431.8 mm), 11" (279.4 mm)

30×42 SERIES

30" (762.0 mm)

MAP SERIES

700 mm (27.6 inches), 500 mm (19.7 inches)

DIN SERIES

707 mm (27.8 inches), 500 mm (19.7 inches)

CHINA SERIES

914 mm (36 inches), 910 mm (35.8 inches), 900 mm (35.4 inches),
880 mm (34.6 inches), 620 mm (24.4 inches), 610 mm (24 inches),
450 mm (17.7 inches), 440 mm (17.3 inches), 310 mm (12.2 inches),
297 mm (11.7 inches)

When using the paper of China series, the paper size of the China series should be also specified. (⇒Page 11-9.)

<Parameter (Choice input method)> : Default value

A SERIES / 9" SERIES / 8.5" SERIES / 30x42 SERIES /
MAP SERIES / DIN SERIES / CHINA SERIES

Note

- ◆ Only choices of MEDIA SERIES which are ON in the ENABLE SERIES of the system menu are displayed.

Chapter 8

"FUNCTION" menu

Chapter 8 describes the "FUNCTION" menu and its operating procedures.

Read this chapter when confirming the setup or adjusting the data or time.

Contents of this chapter

Setting items

Setting items

Function menu is used to execute the plotter functions provided for by this device.

```
#MENU PRINT
>SYSTEM
```

If there is a job standing for processing, this function cannot be operated.

Menu	First hierarchy item	Parameter
FUNCTION	#MENU PRINT >SYSTEM	SYSTEM PORTn PARA USB ALL
	#HPGL SELF PLOT >PORT 1	PORTn PARA USB
	#DSCAN SELF PLOT >PORT 1	PORTn PARA
	#ERROR LOG >PAGE COUNT 1	PAGE COUNT 1 to 5
	#JOB LOG PAGE COUNT 1	PAGE COUNT 1 to 5
	#ENGINE LOG >	
	#SYSTEM DATE >aa/bb/cc	00/00/00 to 99/12/31
	#SYSTEM TIME >aa:bb:cc	00:00:00 to 23:59:59
	#INIT CHARG.INF >	
	#PRINT CHARG.INF >	
	#MAINTE INFO >FAX PRINT	FAX PRINT
	#DATA DUMP >	

MENU PRINT

Prints the system version, device configuration information, parameter setting information and status of consumables, etc.

<Parameter (choice execution method)>  : Default value

SYSTEM	Prints the System menu information (initial value).
PORTn	Prints the setting information for the Ethernet port. ^{Note 1)}
PARA	Prints the setting information for the Parallel channel. ^{Note 2)}
USB	Prints the setting information for the USB channel. ^{Note 2)}
ALL	Prints All of the above setting information.

Note 1) Disabled ports will not be indicated.

Note 2) Parallel and USB will only be indicated when
each interface is installed.

(Sample of print)

```
2007/08/13(FRI) 14:59:38                                     LP-1020 Setup List                                     Ver:01AK12 Page 1

CONFIG
PRODUCT          ) LP-1020          VERSION          ) 01AK12          SERIAL NO       ) 80007
ENGINE           ) 0.11             MILEAGE(m)      ) 2553           BILLING         ) 11385
C-BOARD         ) L.20             E-BOARD        ) 2.11
HARDDISK        ) HIS722540VLA720 VS10AG8A01A 01A 38.3468
MEMORY(MB)      ) 256              SPOOL(MB)       ) 2042.4         PAGE MEMORY(MB) ) 152.3
SNMP COMMUNITY  ) Public
DHCP INFO
STATUS          ) DISABLE

SYSTEM
COMM. PARAM
ETHERNET
PORT SELECT(1-10) ) XLF-----      DHCP           ) DISABLE          IP ADDRESS     ) 128.001.007.007
SUBNET MASK       ) 000.000.000.000
ROUTING TABLE
SETUP DETAILS
ROUTING TABLE2
METRIC            ) 64              ETHERNET ADDR   ) 0800832AE677    CONNECTION SPD ) AUTO
CONNECTION TYPE  ) AUTO          HTTP PORT       ) 80              PORT TIMEOUT   ) 30min
FTP DATA TYPE   ) ASCII/BIN     SNMP            ) OFF             SNMP VERSION   ) V1
TRAP01
MANAGER          ) 000.000.000.000  ERROR           ) ON              JOB            ) OFF
TRAP02
MANAGER          ) 000.000.000.000  ERROR           ) ON              JOB            ) OFF
PARALLEL
TIMING MODE      ) NORMAL         TIMEOUT(100msec) ) 300
USB
TIMEOUT(sec)    ) 10
WEB LOCK         ) OFF
ENABLE SERIES
A SERIES        ) ON             CHINA SERIES    ) OFF
APPLY ROLL
A SERIES        ) ON             USE A1          ) OFF             USE A2         ) ON
USE A3          ) ON
LANGUAGE         ) ENGLISH

DEVICE
POWER SAVE EJECT ) HIGH          POWER SAVE      ) 15min          EDGE CUT TIMER ) OFF
DOOR OPEN CUT   ) OFF          DENSITY        ) NORMAL         TRACE PAP. MODE ) NORMAL

PAPER
ROLL1
PAPER KIND      ) NORMAL       PAPER SERIES    ) A SERIES
ROLL2
PAPER KIND      ) NORMAL       PAPER SERIES    ) A SERIES
ROLL3
PAPER KIND      ) NORMAL       PAPER SERIES    ) A SERIES

PORT1:XPT
PUL SELECT      ) HDTC         XPT PORT       ) 9100

PORT2:LPD
PUL SELECT      ) HDTC         PRINTER NAME   ) LP02

PORT3:FTP
PUL SELECT      ) HDTC         USER NAME      ) FTP03

PARALLEL
PUL SELECT      ) HDTC

USB
PUL SELECT      ) H---
```

HPGL SELF PLOT

Executes self-plotting of HPGL data format built in the device.

<Parameter (choice execution method)> : Default value

PORTn	Executes self-plotting based on the setting information of the PDL table (HPGL) for the port n of Ethernet. <small>Note 1)</small>
PARA	Executes self-plotting based on the setting information of the PDL table (HPGL) for the parallel channel. <small>Note 2)</small>
USB	Executes the self-plotting based on the setting information of the PDL table (HPGL) for the USB channel. <small>Note 2)</small>

Note 1) Disabled ports will not be indicated. If HPGL is not selected at the time of PDL selection.

Note 2) Parallel and USB will only be indicated when each interface is installed.

(Sample of print)

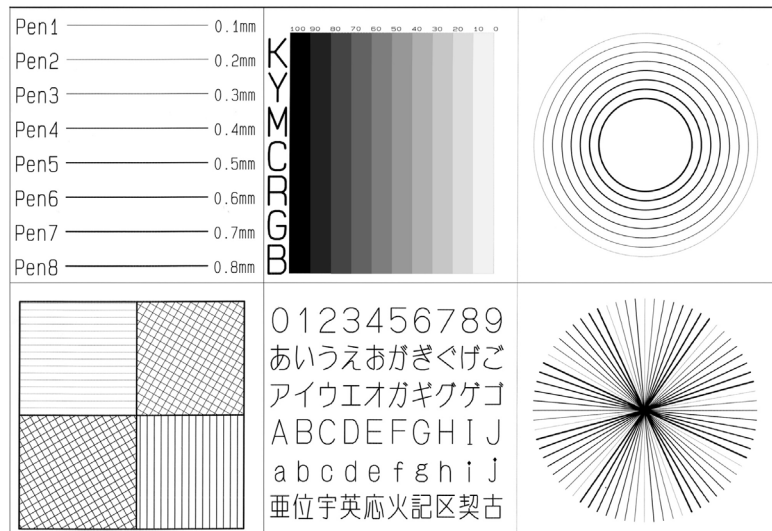

DSCAN SELF PLOT

Executes self-plotting of DSCAN built data format in the device.

Note

- ◆ The DSCAN format is for only customers in Japan.

<Parameter (choice execution method)> : Default value

PORTn Executes self-plotting based on the setting information of the PDL table (DSCAN) for the port n of Ethernet. ^{Note 1)}

PARA Executes self-plotting based on the setting information of the PDL table (DSCAN) for the parallel channel. ^{Note 2)}

Note 1) Disabled ports will not be indicated. If HPGL is not selected at the time of PDL selection.

Note 2) Parallel and USB will only be indicated when each interface is installed.

(Sample of print)

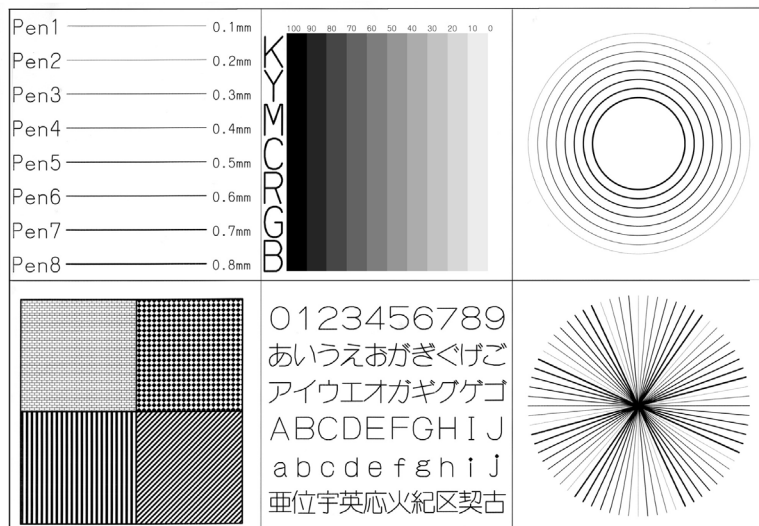

ERROR LOG

Executes error log print by the specified number of pages from the latest error log information.

<Parameter (choice execution method)> : Default value

- PAGE COUNT 1** Prints one page of the latest error log information.
- PAGE COUNT 2** Prints two pages of the latest error log information.
- PAGE COUNT 3** Prints three pages of the latest error log information.
- PAGE COUNT 4** Prints four pages of the latest error log information.
- PAGE COUNT 5** Prints five pages of the latest error log information.

(Sample of print)

```

2007/08/13(FRI) 15:11:33                                LP-1020 Error Log List                                Ver:01AK12 Page 1

Log mode:00D Max log number:8191 Log size:16 Log set count:9
Print Information
9 04/08/13 15:11:08 0 DOOR 2 OPEN
8 04/08/13 15:09:38 0 PAPER JAM 3400
7 04/08/13 15:09:02 0 PAPER JAM 3700
6 04/08/13 15:08:51 0 DOOR 1 OPEN
5 04/08/13 15:07:41 0 DOOR 5 OPEN
4 04/08/13 15:06:07 0 TONER EMPTY
3 04/08/13 15:04:38 0 NO PAPER
2 04/08/13 15:03:42 0 DOOR 2 OPEN
1 04/08/13 15:02:46 0 DOOR 1 OPEN

```

JOB LOG

Executes job log print by the specified number of pages from the latest one.

<Parameter (choice execution method)> : Default value

- PAGE COUNT 1** Prints one page of the latest job log information.
- PAGE COUNT 2** Prints two pages of the latest job log information.
- PAGE COUNT 3** Prints three pages of the latest job log information.
- PAGE COUNT 4** Prints four pages of the latest job log information.
- PAGE COUNT 5** Prints five pages of the latest job log information.

Prints the following items by job log print.

Error log file header information	Print item
Log media	Log media type (log saving place) HDD: Hard disk FLASH: Flush memory
Max log number	No. of logs which can be registered
Log size	1 information log size
Log set count	No. of registered logs

Job information	Print item
Log	Log file saving position (1 to 65535) (4 characters)
Job	Job No. (1 to 999) (3 characters)
Req	Job generation (spool) No. (1 to 999)
PDL	Process PDL (5 characters) HPGL/DSCAN/TIFF/CALS
Port	Protocol, port No. (4 characters) Protocol: Fxx (FTP), Lxx (LPR), Xxx (XPT), PARA, USB Port : 1 to 10
IP-address	IP address (15 characters)
File	File name (12 characters)
User	User name (12 characters)
Input Size	Received data size (5 characters)
Output Page	No. of prints of job (3 characters)
Output Acc	A4/A3 converted No. of prints (3 characters)
Date	Reception date
Job Start	Job start time (reception start time)
Job End	Job end time (print end time)
Counter Acc*10	Total counter (A4/A3 converted) (unit: 1/10 sheets)
Counter Run*10	Total distance (unit: 1/10 m)
Result	Printing status NORMAL: Normal completion DELETE: Data deleted CANCEL: Printing (processing) cancelled ERxxxx: Error corrected (error log No.) EXTRA: Additional printing AGAIN: Reprinting

(Sample of print)

```

2007/08/13(FRI) 15:16:42                               LP-1020 Job Log List                               Ver-01AK12 Page 1
Log media: HDD Max log number: 65535 Log size: 128 Log set count: 10
Log Job Req PDL Port IP-address File User Input Size Output Date Job Job Counter Result
          Size Page Ago Start End Acc-10 Run-10
10 10 10 HPGL F03 128.001.001.001 A1XS.#12 FIPOG 333 1 3 08/13 15:16:03 15:16:25 1138 255 NORMAL
9 9 8 HPGL F03 128.001.001.001 A4XS.#12 FIPOG 326 1 1 08/13 15:14:05 15:14:23 1138 255 NORMAL
8 8 8 HPGL F03 128.001.001.001 A4XS.#12 FIPOG 333 1 1 08/13 15:13:46 15:14:06 1138 255 NORMAL
7 7 7 HPGL --- 000.000.000.000 ELOG.d LOCAL 2437 1 1 08/13 15:11:33 15:11:52 1138 255 NORMAL
6 6 6 HPGL --- 000.000.000.000 ELOG.d LOCAL 2319 1 2 08/13 15:10:48 15:11:07 1138 255 NORMAL
5 5 5 HPGL F03 128.001.001.001 A4XS.#12 FIPOG 334 1 5 08/13 15:08:25 15:10:28 1137 255 NORMAL
4 4 4 HPGL F03 128.001.001.001 A4XS.#12 FIPOG 334 1 5 08/13 15:04:35 15:05:23 1137 255 NORMAL
3 3 3 OSCAN --- 000.000.000.000 SELF.d LOCAL 5632 1 1 08/13 15:02:08 15:02:28 1136 255 NORMAL
2 2 2 HPGL --- 000.000.000.000 SELF.d LOCAL 10117 1 1 08/13 15:01:45 15:02:05 1136 255 NORMAL
1 1 1 HPGL --- 000.000.000.000 MENU.d LOCAL 19259 1 1 08/13 14:59:38 14:59:57 1136 255 NORMAL

```

ENGINE LOG

Prints the engine information.

(Sample of print)

2007/08/13(FRI) 15:17:17		LP-1020 Engine Information		Ver:01AK12 Page 1	
Serial No.)80007				
Version)0.11				
<u>PARAMETER1</u>					
101(120)	201(26517)	301(250)	401(1010)		
102(50)	202(36994)	302(0)	402(668)		
103(120)	203(4961)	303(20)	403(2909)		
104(0)	204(8614)	304(1600)	404(5150)		
105(1000)	205(9874)	305(1600)	405(500)		
106(4)	206(0)	306(1600)	406(723)		
107(5000)	207(59056)	307(1600)	407(3446)		
108(0)	208(10158)	308(0)	408(1050)		
109(0)	209(9449)	309(20)	409(1000)		
110(100)	210(4961)	310(800)	410(668)		
111(100)	211(0)	311(50)	411(2909)		
112(30)	212(0)	312(1000)	412(5150)		
113(30)	213(59599)	313(200)	413(500)		
114(1)	214(0)	314(200)	414(723)		
115(1)	215(100)	315(450)	415(3446)		
116(170)	216(0)	316(1000)	416(2331)		
117(160)	217(59056)	317(500)	417(1000)		
118(170)	218(0)	318(1300)	418(2800)		
119(160)	219(59056)	319(10)	419(200)		
120(100)	220(0)	320(0)	420(1500)		
121(100)	221(59056)	321(59)	421(300)		
122(105)	222(0)	322(60)	422(1820)		
123(1)	223(21323)	323(0)	423(100)		
124(0)	224(7595)	324(1000)	424(1200)		
125(10)	225(7595)	325(50)	425(1016)		
126(3)	226(2)	326(50)	426(0)		
127(6)	227(2)	327(916)	427(1486)		
128(190)	228(2)	328(916)	428(300)		
129(180)	229(0)	329(916)	429(800)		
130(120)	230(384)	330(916)	430(800)		
131(95)	231(11628)	331(0)	431(2300)		
132(15)	232(11628)	332(3)	432(300)		
133(30)	233(11628)	333(100)	433(2300)		
134(15)	234(7371)	334(800)	434(300)		
135(3)	235(7371)	335(1)	435(1900)		
136(0)	236(7371)	336(100)	436(2300)		
137(1)	237(25000)	337(200)	437(0)		
138(990)	238(25000)	338(600)	438(1600)		
139(10)	239(25000)	339(0)	439(300)		
140(50)	240(8329)	340(320)	440(1200)		
141(50)	241(5296)	341(400)	441(0)		
142(10)	242(11628)	342(4800)	442(1600)		
143(90)	243(7371)	343(200)	443(500)		
144(990)	244(6709)	344(0)	444(680)		
145(10)	245(2050)	345(100)	445(100)		
146(100)	246(798)	346(0)	446(0)		
147(300)	247(327)	347(9419)	447(725)		
148(300)	248(1269)	348(3532)	448(2600)		
149(100)	249(327)	349(1291)	449(200)		
150(980)	250(541)	350(50)	450(0)		
151(10)	251(2308)	351(3477)	451(0)		
152(100)	252(769)	352(754)	452(0)		
153(300)	253(2000)	353(300)	453(0)		
154(2700)	254(3888)	354(973)	454(240)		
155(1241)	255(2308)	355(3696)	455(400)		
156(877)	256(5000)	356(918)	456(2000)		
157(0)	257(15000)	357(3159)	457(1000)		
158(0)	258(60)	358(5400)	458(1000)		
159(986)	259(1440)	359(1000)	459(4000)		
160(0)	260(2000)	360(500)	460(0)		
161(221)	261(30)	361(4260)	461(2000)		
162(42740)	262(30)	362(100)	462(0)		
163(47377)	263(6)	363(0)	463(100)		

SYSTEM DATE

Specifies the date (year, month, day).

Enters the date in the christian year.

This setting value is referred to when the menu print, error log or job log is saved.

SYSTEM TIME

Specifies the time (hour, minute, second).

Enters the date in the 24-hour system.

This setting value is referred to when the menu print, error log or job log is saved.

INIT CHARG. INF

Initializes the accounting information (the number of printouts by channel or port) saved in the nonvolatile memory of the device.

PRINT CHARG. INF

Prints the charging information (the number of printouts by channel or port) saved in the nonvolatile memory of this device.

MAINTENANCE INFO

Prints the maintenance information (the total number of printouts by this device) saved in the nonvolatile memory of this device.

DATA DUMP

Prints part of the plotting data in hexadecimal digit.
By this operation, last plotting data of the received plot is dumped.



- ◆ Execute to check if the plotting data is normal.

Chapter 9

"PROTOCOL" menu

Chapter 9 describes the "PROTOCOL" menu and its operating procedures. Read this chapter when setting the communication protocol.

Contents of this chapter

Setting items

Setting items

The protocol menu is used to set up the communication protocol.

```

PROTOCOL
#PORT 1 : XPT
    
```

This device is provided with the interface connector for the Ethernet interface as the standard specification. The Ethernet interface is provided with 10 logical ports. In addition, when parallel and USB interfaces are installed, two types of interface connectors are provided for the parallel interface and USB interface. Thus, this device can receive data from up to 12 computers at the same time.

This menu allows for setting of the items related with the protocol by channel and port.

Setting of the number of ports and protocol used in this device should be changed by the communication parameter, "PORT SELECT", in the system menu (initial values of ports No. and protocols are port 1 = XPT, port 2 = LPD, port 3 = FTP).

Menu	First hierarchy item	Second hierarchy item	Parameter
PROTOCOL	PROTOCOL #PORT 1 : XPT	#PDL SELECT >HDTC	HDTC
		#XPT PORT >9100	9100
	PROTOCOL #PORT 2 : LPD	#PDL SELECT >HDTC	HDTC
		#PRINTER NAME >LP02	LP02
	PROTOCOL #PORT 3 : FTP	#PDL SELECT >HDTC	HDTC
		#USER NAME >FTP03	FTP03
	:		
:			
PROTOCOL #PARALLEL	#PDL SELECT >HDTC	HDTC	

- Note) After this menu is changed, the system is reset.
 When there is a job standing for processing, you can only refer to this menu.
 If you only refer to the menu and do not change it, the system returns to offline condition.
 Disabled port is not displayed.
 The total number of usable ports of XPT, LPD, and FTP is 10.
 * XPT: Raw Protocol (socket)

PDL SELECT

This device supports 4 types of data formats (PDL). Data format (PDL) used for the parallel channel or each Ethernet port can be set up. Select and specify the initial character of each PDL.

<Parameter (character input method)>

4 characters Default value: HDTC
(Select all of HPGL, DSCAN, TIFF, and CALS)

- | | |
|--------------------|---|
| [First character] | Specifies whether to use the HPGL format or not.
If using, select "H".
If not, select "_". |
| [Second character] | Specifies whether to use the DSCAN format or not.
If using, select "D".
If not, select "_". |
| [Third character] | Specifies whether to use the TIFF format or not.
If using, select "T".
If not, select "_". |
| [Fourth character] | Specifies whether to use the CALS format or not.
If using, select "C".
If not, select "_". |

Example 1: When using the HPGL format only

```
# PDL SELECT
> H -
```

Example 2: When using both the HPGL format and TIFF format

```
# PDL SELECT
> H - T -
```

XPT PORT

Specifies the XPT port No. (numerical value)

<Parameter (numerical value input method)>

0 to 65535

Default value: 91xx

xx: Port No.- 1

Do not use the same port number for multiple ports.

Numbers 0 to 1023 are reserved numbers and should not be used.

* XPT: Raw Protocol (socket)

PRINTER NAME

Specifies the LPD printer name (characters).

<Parameter (numerical value input method)>

3 to 8 characters

Default value: LPxx

xx: Port No.

A to Z, 0 to 9, - (hyphen), and _ (under bar) can be used.

Do not use the same printer name in multiple ports.

USER NAME

Specifies the FTP printer name (characters).

<Parameter (numerical value input method)>

3 to 8 characters Default value: FTPxx xx: Port No.

A to Z, 0 to 9, - (hyphen), and _ (under bar) can be used.

Do not use the same printer name in multiple ports.

Chapter 10

"RESET" menu

Chapter 10 describes the "RESET" menu and its operating procedures. Read this chapter when initializing this device.

Contents of this chapter

Reset functions

Reset functions

The reset menu is used to execute the reset functions.

```
# SYSTEM RESET  
>
```

Menu	First hierarchy item	Parameter
RESET	#SYSTEM RESET >	
	#PORT RESET >PORT1	PORT1

SYSTEM RESET

Restarts the system.

Turns the device to power ON condition.

All received data is cleared.

PORT RESET

Executes the communication reset for the selected logical port.
Only active Ethernet ports are displayed for the port reset.

Chapter 11

"SYSTEM" menu

Chapter 11 describes the "SYSTEM" menu and its operating procedures. Read this chapter when setting the communication conditions for the Ethernet, parallel and USB connections or when returning the setting of this device to the setting at the time of shipment from the factory.

Contents of this chapter

Setting items

Setting items

After this menu is changed, the parameters are automatically saved and the system is reset. When there is a job standing for processing, you can only refer to this menu. If you only refer to the menu and do not change it, the system returns to the offline condition.

SYSTEM
COMM . PARAM

Menu	First hierarchy item	Second hierarchy item	Third hierarchy item	Parameter
SYSTEM	SYSTEM #COMM.PARAM	COMM.PARAM #ETHERNET	Note 1)	
		COMM.PARAM #PARALLEL	TIMING MODE NORMAL	NORMAL FAST SLOW
			#TIME OUT (100 msec) >300	1 to 18000
		COMM.PARAM #USB	#TIME OUT (sec) >10	0 to 99
		COMM.PARAM #PlotDataToFile	#PDTF HostIP Adress >000.000.000.000	000.000.000.000 to 255.255.255.255
			#PDTF PORT >33000	0 to 65535
			#PDTF Timeout (sec) >33000	1 to 75
		COMM.PARAM #Teriplot	#Teriplot >OFF	OFF ON
			#Teriplot ADDR >000.000.000.000	000.000.000.000 to 255.255.255.255
		#WEB LOCK >OFF	-	-
	SYSTEM #ENABLE SERIES	Note 2)		
	SYSTEM #APPLY ROLL	Note 3)		
	SYSTEM #CHINA SIZE	Note 4)		
	#INITIAL SET >STANDARD	-	-	STANDARD CHINA
#LANGUAGE >JAPANESE	-	-	ENGLISH JAPANESE	
#LENGTH UNITS >MILLIMETERS	-	-	MILLIMETERS INCHES	
#ADMIN PASSWORD >00000000			00000000 to 99999999	

Note 1) Refer to the chapter of Ethernet parameter.

Note 2) Refer to the "Enable series".

Note 3) Refer to the "Apply roll".

Note 4) Refer to the "China size".

Communication parameter "COMM. PARAM"

This three interfaces that support this device are:

- (1) Ethernet interface
- (2) Parallel interface
- (3) USB interface

This item is used to set up communication parameters by interface.

■ETHERNET

Specifies the Ethernet interface for communication. (Refer to Chapter 12.)

■PARALLEL

Specifies the parallel interface for communication.
Only when the parallel interface installed is displayed.

●TIMING MODE

Specifies the communication conditions (signal timing) for the parallel interface.

<Parameter (choice input method)> : Default value

NORMAL/FAST/SLOW

When the NORMAL, FAST or SLOW parameter is selected, fixed values listed in the table below are automatically specified.

Initial value of communication parameter (parallel)

Item	Fast mode	Normal mode	Slow mode
STROBE timing	Fall edge	Fall edge	Fall edge
ACK on-time	900 nsec	2.4 μsec	3.6 μsec
ACK pulse length	900 nsec	2.4 μsec	3 μsec
BUSY off timing	ACK rise edge	ACK rise edge	ACK rise edge

●TIMEOUT (100msec.)

Specifies the time at which the data reception is considered to have been completed after the data transmission is discontinued (unit: 100 msec).

<Parameter (numerical value input method)>

1 to 18000 Default value: 300

■USB

Specifies the USB interface for communication.

This menu is displayed only when the USB interface is installed.

●TIMEOUT (sec)

Specifies the time at which communication is discontinued after the host device is hung up during communication for some reason (unit: second).

<Parameter (numerical value input method)>

0 to 99 Default value: 10

■PlotDataToFile

Since this setting is only for Japan, leave the setting as it is.

■Teriplot

Specifies whether to use Teriplot or not in operation.

For the operation of Teriplot, refer to Chapter 13 and the documents supplied with the "Teriplot" software package.

●Teriplot

Specifies whether to use Teriplot or not in operation.

<Parameter (choice input method)> : Default value

OFF/ON

●Teriplot ADDR

Specifies the IP address of the computer where Teriplot is installed.

<Parameter (numerical value input method)>

000.000.000.000 to 255.255.255.255 Default value: 000.000.000.000

WEB LOCK

Specifies whether the setup authority from the WEB browser is given to a user administrator or subordinate.

<Parameter (choice input method)> : Default value

OFF/ON

ENABLE SERIES

Specifies effective media series handled by this device.

Menu	Second hierarchy item	Parameter
SYSTEM # ENABLE SERIES	#A SERIES >ON	ON OFF
	#9" SERIES >OFF	ON OFF
	#8.5" SERIES >OFF	ON OFF
	#30×42 SERIES >OFF	ON OFF
	#MAP SERIES >OFF	ON OFF
	#DIN SERIES >OFF	ON OFF
	#CHINESE SERIES >ON	ON OFF

■Paper

Specifies whether to use the following paper of series:

A series, 9" series, 8.5" series, 30×42 series, MAP series, DIN series, or Chinese series

A SERIES ROLL

A0 (841 mm / 33.1 inches), A1 (594.5 mm / 23.4 inches),
A2 (420.5 mm / 16.6 inches), A3 (297.3 mm / 11.7 inches)

9" SERIES ROLL

36" (914 mm), 24" (609.6 mm), 18" (457.2 mm), 12" (304.8 mm)

8.5" SERIES ROLL

34" (863.6 mm), 22" (558.8 mm), 17" (431.8 mm), 11" (279.4 mm)

30×42 SERIES ROLL

30" (762.0 mm)

MAP SERIES ROLL

700 mm (27.6 inches), 500 mm (19.7 inches)

DIN SERIES ROLL

707 mm (27.8 inches), 500 mm (19.7 inches)

CHINA SEIRIES ROLL

914 mm (36 inches), 910 mm (35.8 inches), 900 mm (35.4 inches),
880 mm (34.6 inches), 620 mm (24.4 inches), 610 mm (24 inches),
450 mm (17.7 inches), 440 mm (17.3 inches), 310 mm (12.2 inches),
297 mm (11.7 inches)

<Parameter (choice input method)> : Default value

OFF/ ON

Note

- ◆ The default value varies depending on the INITIAL SETTING.
- ◆ All of these parameters cannot be set to OFF.
- ◆ When this parameter is changed from ON to OFF, the following related parameters must be initialized.
 - MEDIA SERIES in the paper menu
 - Automatic paper feed series in the setup menu

APPLY ROLL

Specifies the roll size by media series.

Menu	Second hierarchy item	Third hierarchy item	Parameter
SYSTEM #APPLY ROLL	APPLY ROLL #A SERIES	#USE A0 >ON	ON OFF
		#USE A1 >ON	ON OFF
		#USE A2 >OFF	ON OFF
		#USE A3 >ON	ON OFF
	APPLY ROLL #9" SERIES	#USE 36" >ON	ON OFF
		#USE 24" >OFF	ON OFF
		#USE 18" >OFF	ON OFF
		#USE 12" >OFF	ON OFF
	APPLY ROLL #8.5" SERIES	#USE 34" >ON	ON OFF
		#USE 22" >OFF	ON OFF
		#USE 17" >OFF	ON OFF
		#USE 11" >OFF	ON OFF
	APPLY ROLL #30×42" SERIES	#USE 30" >ON	ON OFF
	APPLY ROLL #MAP SERIES	#USE B1 >ON	ON OFF
		#USE B2 >OFF	ON OFF
	APPLY ROLL #DIN SERIES	#USE B1 >ON	ON OFF
		#USE B2 >OFF	ON OFF
	APPLY ROLL #CHINA SERIES	#USE A0 >ON	ON OFF
		#USE A1 >OFF	ON OFF
		#USE A2 >OFF	ON OFF
#USE A3 >OFF		ON OFF	

■Each size paper of each series

Specifies whether to use each size paper of the series.

A SERIES /9" SERIES /8.5" SERIES /30×42 SERIES /
MAP SERIES / DIN SERIES / CHINA SERIES

<Parameter (choice input method)> : Default value
OFF/ON

Note

- ◆ The default value varies the INITIAL SETTING.
- ◆ This item is displayed only for choices which are ON in the ENABLE SERIES of the system menu.
- ◆ All of the parameters of the same series cannot be set to OFF.
- ◆ When a roll of each series is loaded into this device, that parameter automatically turns ON.

CHINA SIZE

Specifies the roll size of the Chinese series handled by this device.

Menu	Second hierarchy item	Parameter
SYSTEM #CHINA SIZE	#CHINA A0 >914 mm (36 inches)	914 mm (36 inches) 910 mm (35.8 inches) 900 mm (35.4 inches) 880 mm (34.6 inches)
	#CHINA A1 >620 mm (24.4 inches)	620 mm (24.4 inches) 610 mm (24 inches)
	#CHINA A2 >450 mm (17.7 inches)	450 mm (17.7 inches) 440 mm (17.3 inches)
	#CHINA A3 >310 mm (12.2 inches)	310 mm (12.2 inches) 297 mm (11.7 inches)

■ Each size paper of Chinese series

Specifies the paper size from A0 to A3 of the Chinese series.

Note

- ◆ This item is displayed only when the CHINESE SERIES of the ENABLE SERIES in the system menu is ON.

INITIAL SET

Initializes the parameters which are specified in this device to optimum values in each country.

<Parameter (choice input method)> : Default value

STANDARD/CHINA

Note

- ◆ Select "CHINA" if this device is used in China. When this device is used in a country other than China, select "STANDARD."

Initialization of setting

Classification	Function	Applicable scope
SETUP	Specifies up parameters for printing.	All parameters return to their default value.
DEVICE	Specifies the operating status for the engine device.	All parameters return to their default value.
PAPER	Specifies the paper roll type and series	All parameters return to their default value.
FUNCTION	Specifies the menu printing or self-plotting	-
PROTOCOL	Specifies the protocol by channel and port. After this setting is changed, the system is reset.	All parameters return to their default value.
RESET	Resets the system.	-
SYSTEM	Specifies and displays the system parameters. After this setting is changed, the system is reset.	All parameters return to their default value (including the IP address). Display language does not return to the default value.

LANGUAGE

Switches the message display on the LCD.

<Parameter (choice input method)> : Default value
JAPANESE/ENGLISH

LENGTH UNITS

Switches the length unit (millimeter or inch).

<Parameter (choice input method)> : Default value
MILLIMETERS/INCHES

ADMIN PASSWORD

Specifies the administrator password. This password prevents the settings of the plotter from being changed.

<Parameter (numerical value input method)>
00000000 to 99999999 Default value: 00000000

Note

- ◆ Write the administrator password down for remembrance sake. If you should forget the administrator password, the plotter should be initialized, in which case all the settings will return to the factory default settings.

When the administrator password is specified, the following password verification window appears before proceeding to the menu screen.

Enter the administrator password according to the procedure given below.



ADMIN PASSWORD
* 0 0 0 0 0 0 0 0



1 Press the key .

Press the  key is pressed, the digit of numeric value can be moved.



ADMIN PASSWORD
* 0 0 0 0 0 0 0 0

2 Press the or key.

If the  or  key is pressed, numeric value can be changed.

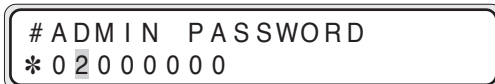

ADMIN PASSWORD
* 0 2 0 0 0 0 0 0

Repeat the Steps 1 and 2 to enter the eight-digit administrator password.

3 Press the key.

If the  key is pressed, the screen changes as shown below.



MENU
SETUP



- ◆ If the  key is pressed when the administrator password is “00000000”, the user-level menu mode appears. The user-level menu mode has the display and settings restrictions as below:

- Items that are displayed but cannot be set

Menu	First hierarchy item	Second hierarchy item
SYSTEM	COMM.PARAM	-
PROTOCOL	-	-

- Items that are not displayed

Menu	First hierarchy item	Second hierarchy item
SYSTEM	-	ADMIN PASSWORD
FUNCTION	-	-

Chapter 12

Ethernet parameter "ETHERNET"

Chapter 12 describes the "Ethernet" menu and its operating procedures. Read this chapter when setting the communication conditions for the Ethernet, parallel, and USB connections or when returning the setting of this device to the setting at the time of shipment from the factory.

Contents of this chapter

Setting items

Setting items

Ethernet parameter is an item in the system menu. After this menu is changed, the parameter is automatically saved and the system is reset.

When there is a job standing for processing, you can only refer to this menu.

If you only refer to the menu and do not change it, the system returns to the offline condition.

Menu	Third hierarchy item	Fourth hierarchy item	Fifth hierarchy item	Parameter	
COMM.PARAM # ETHERNET	#PORT SELECT 1-10 >XLF-----			Choice input method <small>Note 1)</small> (X, L, F, -)	
	#DHCP > DISABLE			DISABLE ENABLE	
	#IP ADDRESS >000.000.000.000			Input value <small>(Note 2, 6)</small>	
	#SUBNET MASK >000.000.000.000			Input value <small>(Note 6)</small>	
	#ROUTING TABLE	#GATEWAY ADDR 01 >000.000.000.000			Input value <small>(Note 6)</small>
		#NETWORK ADDR 01 >000.000.000.000			Input value <small>(Note 3, 6)</small>
	#ROUTING TABLE 2	#GATEWAY ADDR 02 >000.000.000.000			Input value <small>(Note 6)</small>
		#NETWORK ADDR 02 >000.000.000.000			Input value <small>(Note 3, 6)</small>
		:			
		:			
		#GATEWAY ADDR 10 >000.000.000.000			Input value <small>(Note 6)</small>
	#SETUP DETAILS	#NETWORK ADDR 10 >000.000.000.000			Input value <small>(Note 3, 6)</small>
		#METRIC >064			Input value 1 to 255
		#ETHERNET ADDR >0800832Annnn			Reference only nnn: serial No.
		#CONNECTION SPD. >AUTO			AUTO 100 10
		#CONNECTION TYPE >AUTO			AUTO FULL HALF
		#HTTP PORT >00080			Input value 0 to 65535
#PORT TIME OUT >30min				OFF 5min 10min 15min 30min	

Menu	Third hierarchy item	Fourth hierarchy item	Fifth hierarchy item	Parameter	
COMM.PARAM # ETHERNET	#SETUP DETAILS	#FTP DATA TYPE		ASCII/BIN	
		>ASCII/BIN		BIN	
		#SNMP		OFF	
		>OFF		ON	
		#SNMP VERSION		V1	
		>V1		V2	
		#TRAP01	#MANEGER	>000.000.000.000	Choice input method
			#ERROR	>ON	ON OFF
			#JOB	>OFF	OFF ON (IP ADDRESS) ON (PORT)
			#IP ADDR	>000.000.000.000	Choice input method? (Note 4)
			#PORT	>ALL	ALL (Note 5) PORT01 . PORT10
		#TRAP02	#MANAGER	>000.000.000.000	Choice input method
			#ERROR	>ON	ON OFF
			#JOB	>OFF	OFF ON (IP ADDRESS) ON (PORT)
			#IP ADDR	>000.000.000.000	Choice input method? (Note 4)
#PORT	>ALL		ALL (Note 5) PORT01 . PORT10		

Note 1) Up to 10 ports including XPT, LPD, FTP can be specified.

The initial value is 1 port for each protocol.(XLF—————)

Setting example: # PORT SELECT 1-10

>FFFXXLLL_.....In case of 3 ports for each protocol.

Note 2) Same as the IP address specified in the installing operation.

Note 3) Network address is indicated only when the "Gateway address" is specified.

Note 4) To be displayed only when the "TRAPnn job" is set to ON (IP address).

Note 5) To be displayed only when the "TRAPnn job" is set to ON (PORT).

Note 6) Not to be displayed when "DHCP" is set to enable.

PORT SELECT

Selects the Ethernet port and protocol.

10 ports are expressed in 10 digits on LCD.

Port selectors 1 to 10 selects ports 1 to 10.

<Parameter (choice input method)>

X/L/F/-

X : XPT protocol (XPT: Raw Protocol (socket))

L : LPD protocol

F : FTP protocol

- : Not set

1234567890

(Port select 1-10) Default: XLF_____

DHCP

Selects whether to enable or disable the DHCP.

<Parameter (choice input method)> : Default value

DISABLE Disables the DHCP.

ENABLE Enables the DHCP.

IP ADDRESS

Specifies the IP address (Internet address) of this device. This parameter is the same as that specified the installing operation.

<Parameter (numerical input method)>

000.000.000.000 to 255.255.255.255

Default value: 000.000.000.000 (not set)

For instance, when the IP address is 130.28.3.10, specify 130.028.003.010.

SUBNET MASK

Specifies the subnet mask of the network to which this device belongs.

<Parameter (numerical input method)>

000.000.000.000 to 255.255.255.255

Default value: 000.000.000.000

ROUTING TABLE

Specifies the routing table of this device. It is used to connect this device to a host of other network.

■GATEWAY ADDR

Specifies the Router IP address.

<Parameter (numerical input method)>
000.000.000.000 to 255.255.255.255

Default value: 000.000.000.000 (not set)

■NETWORK ADDR

Specifies the network address

<Parameter (numerical input method)>
000.000.000.000 to 255.255.255.255

Default value: 000.000.000.000

Notes

- ◆ If the gateway address is not specified, it is not displayed.
- ◆ When this setting value is "000.000.000.000," it means the default routing is specified.

SETUP DETAILS

Specifies details of other Ethernet items.

■ROUTING TABLE 2

Specifies the routing table from the second to tenth items of this device.
It is used to connect this device to a host of other network.

●GATEWAY ADDR [Gateway address 02-10]

Specifies the router IP address.

<Parameter (numerical input method)>

000.000.000.000 to

255.255.255.255

Default value: 000.000.000.000

●NETWORK ADDR [Network address 02-10]

Specifies the network address.

<Parameter (numerical input method)>

000.000.000.000 to

255.255.255.255

Default value: 000.000.000.000

Note

- ◆ If the gateway address is not set (000.000.000.000), it is not displayed.

■METRIC

Specifies the metric.

<Parameter (numerical input method)>

1 to 255

Default value: 64

■ETHERNET ADDR

This is a physical address peculiar to this device.

Ethernet address of this device is "0800832Annnn."

This parameter is displayed, but cannot be specified.

■CONNECTION SPD.

Specifies the communication speed.

<Parameter (choice input method)> : Default value

AUTO Automatically recognizes 100BASE/10BASE.

100 Sets to 100BASE.

10 Sets to 10BASE.

■CONNECTION TYPE

Specifies the connection type.

<Parameter (choice input method)> : Default value

AUTO	Automatically recognizes Full Duplex/ Half Duplex.
FULL	Sets to Full Duplex.
HALF	Sets to Half Duplex.

■HTTP PORT

Specifies the HTTP port when using the Web function.

<Parameter (numerical input method)>

0 to 65535

Default value: 80

■PORT TIMEOUT

Selects the closing time of TCP port. Operation starts when no data is transmitted while being transferred.

<Parameter (choice input method)> : Default value

OFF	Does not time out.
5 min	Set to 5 minutes.
10 min	Set to 10 minutes.
15 min	Set to 15 minutes.
30 min	Set to 30 minutes.

■FTP DATA TYPE

Specifies the initial value of the data transfer type when receiving ftp data.

<Parameter (choice input method)> : Default value
ASCII/BIN/BIN

■SNMP

Specifies the SNMP operation. When the setting is ON, SNMP is enabled.
The SNMP community name can be specified using the Web name.

<Parameter (choice input method)> : Default value
ON/OFF

■SNMP VERSION

Specifies the SNMP version.

<Parameter (choice input method)> : Default value
V1/V2

■TRAP** (** : 01 - 02)

●MANAGER

Specifies the manager IP address to return TRAP.
When the following TRAP conditions are OFF, TRAP does not occur in
this setting.

<Parameter (numerical input method)>
000.000.000.000 to 255.255.255.255

Default value: 000.000.000.000
(TRAP is the same when it is OFF if not registered.)

●ERROR

Specifies whether to transmit the TRAP if an engine-related error occurs (except for technical call error).

When an error occurs, TRAP is sent to the TRAP manager which was specified in the TRAP manager described above.

If the TRAP manager item is not specified, setting to ON is disabled.

<Parameter (choice input method)> : Default value
ON/OFF

●JOB

Specifies whether to send the TRAP at the completion of job printing.

When this operation is not set to OFF, TRAP conditions can be specified by TRAP**:**IP** address or TRAP**:**PORT** operation.

<Parameter (choice input method)> : Default value
OFF/ON (IP address)/ON (PORT)

●IP ADDR

IP address is enabled and can be specified setting when the <ON (IP address)> is selected from the operation TRAP** job menu. When specified IP address is identical to the IP address of the receiving host, TRAP is transmitted to the TRAP manager. When it is set to 000.000.000.000, TRAP is transmitted to all jobs received.

<Parameter (numerical input method)>
000.000.000.000 to 255.255.255.255

Default value: 000.000.000.000

●PORT

Port is enabled and can be specified when <ON (PORT)> is selected from the operation TRAP** job menu. After completion of printing all jobs transmitted to the specified port of this device, TRAP is transmitted to the TRAP manager.

<Parameter (choice input method)> : Default value

ALL/PORT1/PORT2/.../PORT10

Chapter 13

Teriplot

Chapter 13 describes the Teriplot software supplied with the plotter (Note, in Asian and Oceania countries, the Teriplot software is available as the option).

Contents of this chapter

About Teriplot
Teriplot Hardware Requirements
Settings
Restrictions

About Teriplot

Teriplot software supplied with the plotter enables integrated control of the plotter as follows (Note, in Asian and Oceania countries, the Teriplot software is available as the option).

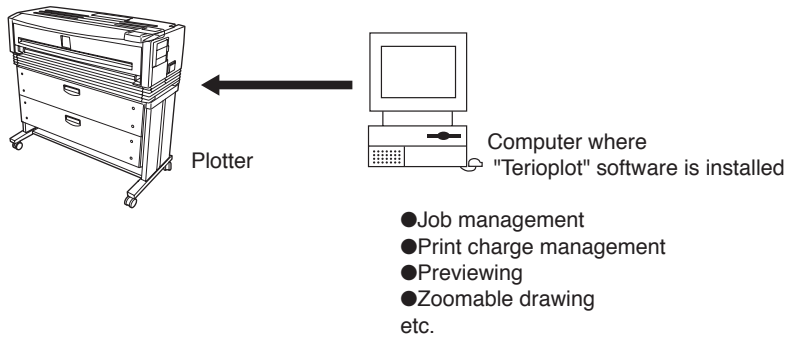

Notes

- ◆ The Teriplot software is not supplied for the one-step roll model because this model does not support the Teriplot software.

Teriplot Hardware Requirements

The Teriplot operation requires the following hardware environment:

Host Computer Operating System:

Microsoft Windows XP Professional 32-bit, SP2 or higher

Host Computer Requirements

- CPU: AMD Athlon™ 2GHz or more
Intel® Pentium® 4 3GHz or more
Intel® Core™ 2 1.8 GHz or more
- Memory: 1 GB RAM, 2 GB recommended
- Display controller: 1024*768 pixels resolution or more, running in true color mode (16777216 colors).
- Touch screen monitor: 1024*768 pixel resolution or more
- Hard disk drive: 100 GB free space
- CD disk drive: Is required for software installation
- USB drive: USB-2
- Network interface: TCP/IP Configuration is required
- Direct X: Is required when using DWG/DXF/DWF option
- Dot Net Framework: Installation is required
- Keyboard: Is required for software installation

Settings

In order to operate the plotter using the Teriplot software, it is necessary to preset the plotter, install the Teriplot software and specify various settings. For details, see the documents supplied with the Teriplot software package.

The documents supplied with this software also describe how to use and how to configure.

Notes

- ◆ When using the Teriplot software, ensure that the "A SERIES" of ENABLE SERIES in the system menu is set to "ON." The default setting is "ON."

Restrictions

There are the following restrictions when the plotter is connected with the Teriplot computer and operated.

- Receiving print data via network connection

Only the host computer where Teriplot is installed can receive print data via a network connection.

- Receiving print data via USB or parallel connection

Print data cannot be received via USB or parallel connection. In addition, the USB and parallel communications settings cannot be displayed on the operation panel or in the PDL setup over the web or communication parameters.

- WEB function

A web connection can only be established with the host computer where Teriplot is installed.

- SNMP setting

When “Teriplot” is set to “ON” in this plotter, the SNMP setting is regarded as “ON” even if it is set to “OFF”, and the plotter runs.

Chapter 14

Troubleshooting

Chapter 14 describes a troubleshooting method for this device. If the trouble is not resolved despite the corrective measures, contact your dealer or our service center.

Contents of this chapter

Troubleshooting

When an error message appears

Error log

Troubleshooting for ethernet

If "BOTTLE MAINT. STARTS" appears

When a print error occurs

When there is an abnormal sound

Troubleshooting

Before calling your dealer or our service center, check the following items and take corrective measures.

■ Items to be checked

Symptom	Items to be checked	Corrective measure
No power	Power cable connection	Plug the power cable into the outlet correctly.
	Power supply to the outlet	Supply the power to the outlet.
Failure to start or operate correctly	ERROR lights and LC message display	Take appropriate measures according to the error message. ⇒Page 14-3
Failure to plot	Interface cable connection	Connect the interface cable correctly.
	ERROR lights and LC message display (See "Note" below)	Take appropriate measures according to the error message. ⇒Page 14-3
Failure to plot transmitted data immediately	DATA lights (on or flashing?)	Review the time-out setting.
Frequent paper jam	Paper type	Check whether the paper type setting matches the type of the loaded paper. ⇒Page 7-2 Use our recommended paper. ⇒Page 1-7
	Paper roll	Load the paper correctly. ⇒Page 2-16
	Check whether there is any foreign material in the paper path	Remove any foreign material. ("Paper Jam" ⇒Page 14-3)

Note

- ◆ In case of a communication warning or data error, the ERROR lamp does not light. Also, an error message, even if displayed, will disappear when the next operation is performed.

If a problem occurs between the computer and the device immediately after the line connection, check the LCD for presence of a communication warning (⇒ page 14-20) at the time of transmission of data to the device.

For a data error, an error message can be printed on the drawing (⇒ page 14-22).

When an error message appears

When the ERROR lamp lights, first check the message displayed on the LCD.

The error messages are as follows. Take corrective measures according to the error message displayed.



- ◆ In case of a communication warning or data error, the ERROR lamp does not light. Also, an error message, even if displayed, will disappear when the next operation is performed.

Paper Jam

If a paper jam occurs, the ERROR lamp lights and the following error message appears on the LCD.

OPEN DOOR 9 , 4
REMOVE PAPER

According to the paper jam point, the door number from which the corrective measure starts is displayed (plural numbers may be displayed as shown above).

- DOOR 1 : Paper jams in the roll 1 drawer. Open the roll 1 drawer and take a corrective measure.
- DOOR 2 : Paper jams in the roll 2 drawer. Open the roll 2 drawer and take a corrective measure.
- DOOR 4 : Paper jams in the manual feed drawer. Open the manual feed drawer and take a corrective measure.
- DOOR 5 : Paper jams in the main body (cutter area). Open the cutter door and take a corrective measure.
- DOOR 6 : Paper jams in the main body. Open the top cover and take a corrective measure.
- DOOR 9 : Paper jams in the manual paper feed holder. Open the cutter door inside and manual feed drawer, and take a corrective measure.

In case of a paper jam, open the door of the displayed door number, and take a corrective measure according to the procedure given below.

■ Clearing paper jam in main body

OPEN DOOR 6
REMOVE PAPER

1 Open the top cover.

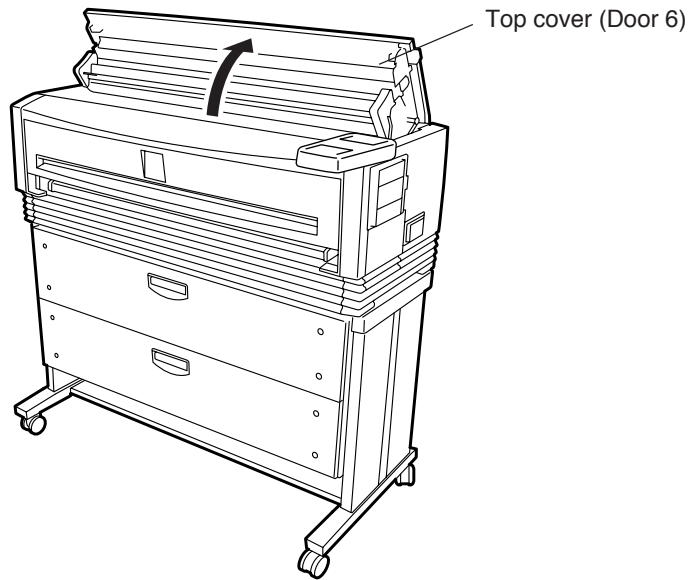

2 Remove the jammed paper.

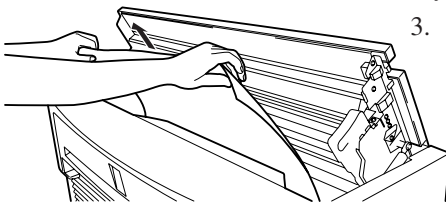

If you cannot see the jammed paper, refer to step 3.

After you removed the jammed paper, refer to step 5.

3 Open the manual paper feed holder and the fixation door.

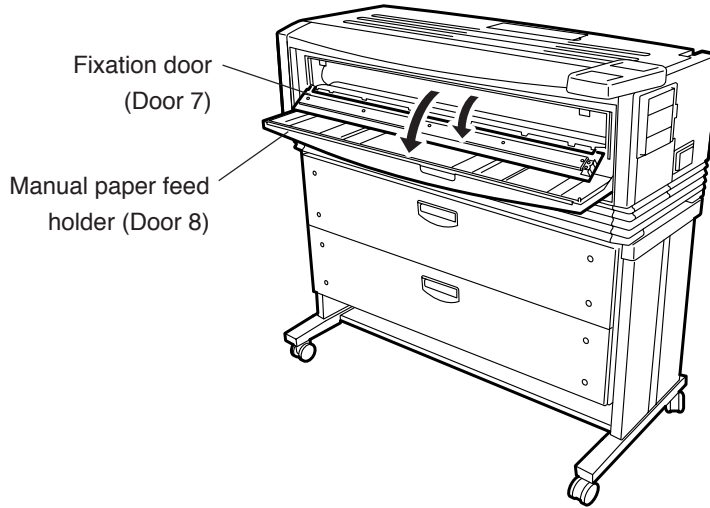

4 Remove the jammed paper.

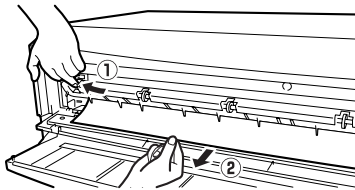

- ① Lift the paper guide.
- ② Remove the paper gently so that toner does not spill.

Warning

- ◆ The fixation is very hot. Do not touch it. Touching the fixation could cause you to get burned.

If the jammed paper is not visible, the paper may be jammed inside the main body (cutter area). See “Clearing paper jam in main body (cutter area)” (⇒ page 14-7).

5 Close the top cover, fixation door and manual paper feed holder.

After you closed the top cover, fixation door and manual paper feed holder, the following message appears on the LCD, and then the plotting restarts from the drawing that jammed.

WAIT A MOMENT



PRINT XX / XX * S 0 0 1
F 0 1 X X X X J 0 0 9

■Clearing paper jam in main body (cutter area)

OPEN DOOR 5
REMOVE PAPER

1 Open the cutter door.

Loosen the two knobs and open the cutter door gently.

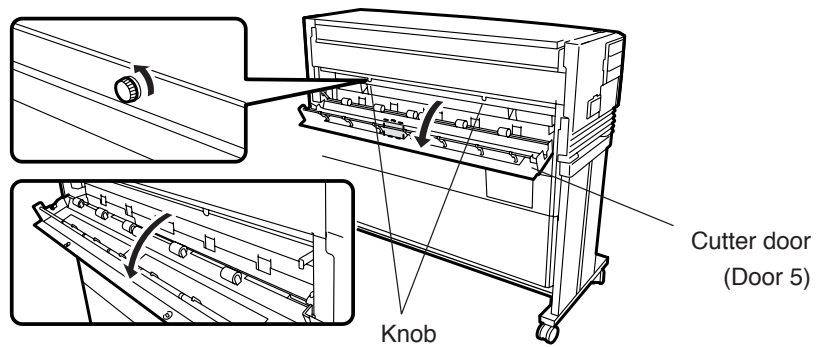

2 Remove the jammed paper and close the cutter door.

After you closed the cutter door, the following message appears on the control panel, and then the plotting restarts from the drawing that jammed.

WAIT A MOMENT



PRINT XX / XX * S 0 0 1
F 0 1 XXXX J 0 0 9

■Clearing paper jam in manual feed drawer

OPEN DOOR 9 , 4
REMOVE PAPER

OPEN DOOR 6 , 9 , 4
REMOVE PAPER

1 (When DOOR 6 is displayed) Open the top cover (Door 6).

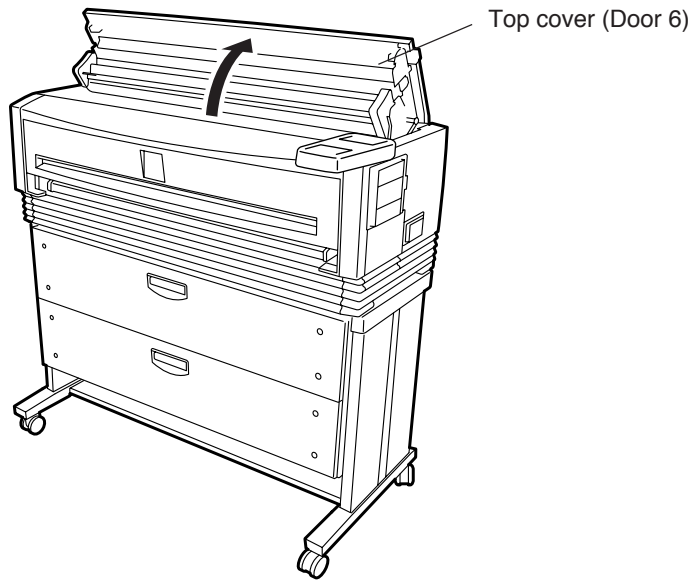

2 Open the cutter door.

Loosen the two knobs and open the cutter door gently.

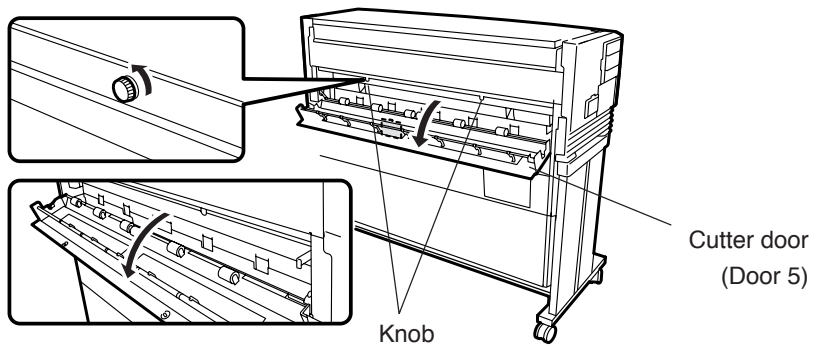

3 Open the cutter door inside.

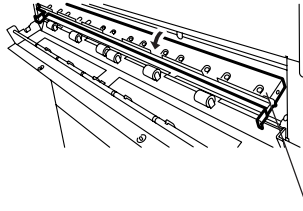

Cutter door inside (Door 9)

4 Open the manual feed drawer toward you.

⚠ Caution

- ◆ The manual feed drawer will fall if you pull it out to far. Thus, take care not to let it fall on your feet to avoid injury.

Manual feed drawer (Door 4)

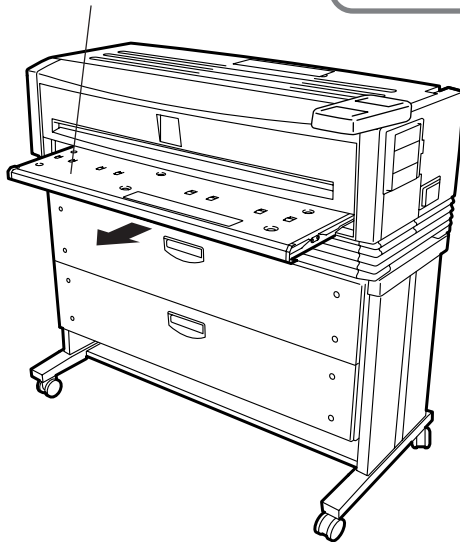

-
- 5** Remove the jammed paper, insert the manual feed drawer and close the cutter door inside as well as the outside cutter door (door 5).

After you closed the door, the following message appears on the control panel, and then the plotting restarts from the drawing that jammed.

WA I T A M O M E N T



PRINT XX / XX * S 0 0 1
F 0 1 X X X X J 0 0 9

■Clearing paper jam in roll 1 or 2 paper roll drawer (if so equipped)

OPEN DOOR X
REMOVE PAPER

OPEN DOOR 5, X
REMOVE PAPER

* X denotes the door number 1 or 2.

1 (When DOOR 5 is displayed) Open the cutter door (⇒Step 1 on page 14-7).

Loosen the two knobs and open the cutter door gently.

2 Pull out the Roll 1 or Roll 2 drawer.

Use your fingers to grasp the handle at the center of the drawer and pull the drawer out gently.

(The illustration indicates a case where the Roll 2 drawer is opened.)

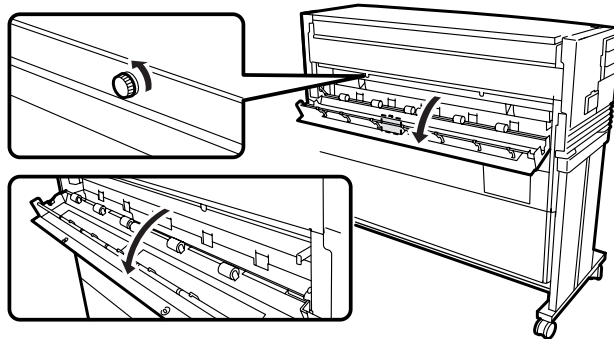

3 Rewind the end of roll paper.

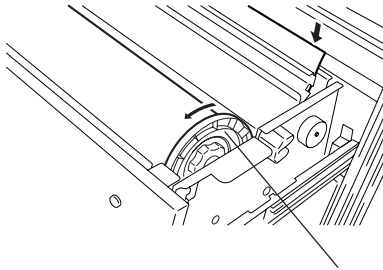

Turn the paper flange in the direction indicated in the illustration to such extent that the end of the wrinkled roll paper is visible.

Paper flange

4 Cut the end of the paper.

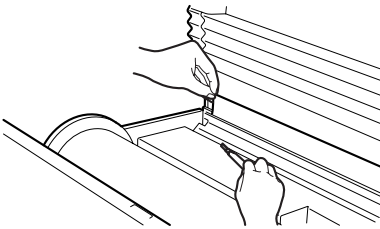

While holding the end of the paper roll, cut it with the cutter removing all of the wrinkled paper.

A "Paper cutter position" label is affixed to both ends of the space where the cutter blade should be inserted. Insert the cutter blade into the space beneath where the label arrow is pointing. Slide the cutter blade along the space and cut the paper.

Caution

- ◆ Take care not to hurt yourself or damage the device when handling the cutter.
- ◆ Handle the cutter blade with care so that you do not break it.



- ◆ Apply the cutter to the direction horizontally to the paper guide. If not, paper may be wrinkled.

5 Close the roll paper drawer and the cutter door.

After you close the drawer and the door, the following message appears on the LCD, and then the plotting restarts from the drawing that jammed.

WAIT A MOMENT



PRINT XX / XX * S 0 0 1
F 0 1 XXXX J 0 0 9

Door Open

If the door is opened, the following message appears on the control panel.

■Roll 1 drawer (Door 1)

CLOSE DOOR 1

Description : The roll 1 drawer is opened.

Measure : Close the roll 1 drawer.

■Roll 2 drawer (Door 2)

CLOSE DOOR 2

Description : The roll 2 drawer is opened.

Measure : Close the roll 2 drawer.

■Manual feed drawer (Door 4)

CLOSE DOOR 4

Description : The manual feed drawer is opened.

Measure : Close the manual feed drawer.

■Cutter door (Door 5)

CLOSE DOOR 5

Description : The cutter door is opened.

Measure : Close the cutter door.

Note: See door locations on the drawing at 1-11 and 1-12.

■Top cover (Door 6)



Description : The top cover is open.

Measure : Close the top cover.

■Fixation door (Door 7)



Description : The fixation door is open.

Measure : Close the fixation door.

■Manual paper feeding holder (Door 8)



Description : The manual paper feed holder is open, and thus the rolled paper cannot be printed.

Measure : Close the manual paper feed holder.

Note: See door locations on the drawing at 1-11 and 1-12.





Operator Call

For this error message, the operator can take corrective action.
Take measures according to the displayed error message.
However, if the same symptom recurs frequently, please contact your dealer or our service center.



SETUP IS WRONG
INITIAL SET

Description : The set up area is checked at powering on, and if the contents are damaged, this message appears.

Measure : Press the  key to display the INITIAL SET screen, and select and execute the initial setting with the    keys.

Warning

■Operator notice warning

W SPOOL INITIALIZED
JOB WAS DELETED

Description : The saved job has been damaged, and thus the spool area is initialized (When HDD is installed).

Measure : After 3 seconds, the message changes to “WAIT A MOMENT” and then the device starts.

W JOB WAS DELETED

Description : The received data is in a format not supported by the device, and thus the data was ignored.

Measure : Use the data in a format supported by the device.

W SPOOL ERROR

Description : The spool area on the HDD has been damaged, and thus the memory spool area is used (When HDD is installed).

Measure : If the device does not recover from this error when you turn the power off and on, please notify your dealer or our service center of the displayed error message and error condition.



W NVRAM ERROR

Description : The nonvolatile memory (NVRAM) of the device has been damaged. Usual printing can be performed, but some functions that use this area may not operate correctly.

Measure : If the device does not recover from this error by turning the power off and on, please notify your dealer or our service center of the displayed error message and error condition.

**DELETE JOB ?
Y=ENTER N=CANCEL**

Description : This message appears if there is an unprocessed job (jobs standing by for processing) at powering on.

Measure : Select whether the job is deleted or not by pressing the  key or  key. The operation goes into time-out in about 10 seconds unless the key is pressed, and the device starts with the job saved.

If a job has been left at powering on

Job status	Display	Transaction
Standing for processing	DELETE JOB?	Job is deleted by designation.
Processing	-	Job is automatically moved to "already processed" job.
Processed	-	Jobs are automatically deleted in order from the oldest job .

W UN - INIT . NVRAM

Description : This message appears if the nonvolatile memory (NVRAM) of the device is not initialized.

Measure : The display of this warning message continues until the  key is pressed.

After the  key is pressed, the NVRAM is initialized automatically and the display changes to the language setting specifically for the installing operation.

■Communication warnings

Description : A communication error message appears if any communication error occurs between the computer and the device. For a practical description, see the following table.

Measure : If the device does not recover from this error by turning the power off and on, follow the guidelines described in the Measure column of the table. If the error is not removed, please notify your dealer or our service center of the displayed error message and error condition.

Note

- ◆ A communication warning appears on the LCD, but it disappears when the next operation is performed. Consequently, you may not recognize that the error occurred. In such a case, retransmit the data to check if the communication warning is displayed on the LCD.

(1) Ethernet interface

W I N T E R F A C E - L N x x x x

xxxx: Error code

Error code	Description	Measure
0101	Duplication of XPT port number	Specify the parameter at the device side correctly.
0212	Lack of internal memory	If the device does not recover from this error by turning the power off and on, take the following measures: - Check if the communication condition and protocol match the specifications of the computer. - Check if the connection cable is defective or is connected securely. - If the error is not removed, please notify your dealer or our service center of the displayed error message and error condition.
0220 to 022F	Protocol data sent from the host is defective	
0250 to 025F	Host disconnects the communication forcibly while a connection is established	
0260 to 026F	Communication to the host failed while communication time out data is transferred	
1000 to 4FFF	Communication connection system error	
5000 to 7FFF	Communication system internal error	

(2) Mail interface

W I N T E R F A C E - M L x x x x

xxxx: Error code

Error code	Description	Measure
1100 to 11FF	SMTP server address is not specified.	Specify the SMTP server address.
1200 to 12FF	SMTP server is not found.	<ul style="list-style-type: none"> - Check the SMPT server for its address setting and the SMPT server host for its status, setting, and connection. - If the error is not removed, please notify your dealer or our service center of the displayed error message and error condition.
1300 to 1AFF	SMPT server ignored protocol, or SMPT server does not respond.	
1B00 to 1BFF	SMPT server ignored the terminating processing.	

(3) USB interface

W I N T E R F A C E - U S x x x x

xxxx: Error code

Error code	Description	Measure
0300 to 04FF	Lack of internal memory	If the device does not recover from this error by turning the power off and on, take the following measures: <ul style="list-style-type: none"> - Check if the communication condition and protocol match the specifications of computer. - Check if the connection cable is defective or connected securely. - If the error is not removed, please notify your dealer or our service center of the displayed error message and error condition.
2100 to 24FF	Protocol data sent from the host is defective	
0100 to 01FF	Communication to the host failed while communication time out data is transferred	
1000 to 1FFF	Communication connection system error	
2000 to 2FFF	Communication system internal error	

■PDL warning

Description : This message appears if any problem exists in the data sent from the computer.

Measure : Remove the cause of problem, and recreate the data correctly. For practical measures, see the table.

Note

- ◆ The PDL warning appears on the control panel, but it disappears when the next operation is performed. Consequently, you may not know that the error occurred.
- ◆ It is recommended that the “ERROR MEMO” of “DRAWING PARAM.” in the setup menu be turned on, so that the error message is printed on the drawing.

W DATA x x x x

xxxx: Error code

Error code	Printed error memo	Description	Measure
0100	W FORMATERROR	D-SCAN format is erroneous.	Analyze the data dumped together with the error message, and correct erroneous part at the computer side.
0201	W COMMAND ERROR	HP-GL or HP-GL/2 command not supported was received.	Correct erroneous part at the computer side.
0202	W # OF PARAM. ERROR	The number of parameters of HP-GL or HP-GL/2 command is wrong.	
0203	W PARAM._RANGE_ERR	The plotting instruction that exceeds the range supported by HP-GL or HP-GL/2 command, or the plotting instruction that uses illegal characters was received.	
0205	W UNDEFINED COMMAND	Character set instruction of HP-GL or HP-GL/2 command not supported was received.	
0207	W POLYGON_BFFR_ERR	Polygon buffer overflow error occurred.	Correct erroneous part at the computer side. (Polygon buffer upper limit: 106600 points)
0208	- (No error memo)	Data is ignored, because there is no effective plotting data exists in HP-GL command.	Check the computer side if effective plotting data is transferred.
0209	W CHAR._OVERFLOW	There is no empty area in memory for user registered characters of HP-GL (DL/UC command).	Correct so as to reduce the number of registrations or data by one character.
0300	W PATTERN OVERFLOW	There are too many pattern registrations in one drawing and the pattern memory overflows.	Reduce the pattern registrations in one drawing.
0301	W HATCH OVERFLOW	There are too many hatch registrations in one drawing and the pattern memory overflows.	Reduce the hatch registrations in one drawing.
0303	W CHAR._OVERFLOW	There is no empty area in memory for user registered characters of HP-GL.	Correct so as to reduce the number of registrations or data by one character.

Error code	Printed error memo	Description	Measure
0305	W SPOOL OVERFLOW	The spool memory overflows.	Install optional HDD, or specify the CENTERING = OFF if the device is used with the CENTERING = ON.
0306	W POLYGON OVERFLOW	Polygon buffer overflow error occurred.	Correct erroneous part at the computer side. (Polygon buffer upper limit: 106600 points)
0307 to 0313	W PDL ERR 307 to W PDL ERR 313	Program warning	If the error is reproducible and the print result is poor, the software must be upgraded to the latest version. Please notify your dealer or our service center of the displayed error message and error condition.
0314	W DATA IGNORED	Data is ignored, because there is no effective plotting data.	Check the computer side if effective plotting data is transferred.
0400	W RASTER_DECODE_ERR	The format of the compressed raster data is erroneous.	Check the computer side if the format of the compressed raster data is correct.
0401	W RASTER_FORMAT_ERR	There is no raster data of the size specified by the data.	Check the computer side if data is correct.
0500 to 0505	- (No error memo)	Program warning	If the error is reproducible and the print result is poor, the software must be upgraded to the latest version. Please notify your dealer or our service center of the displayed error message and error condition.
0600	W FORMATERROR	TIFF data is erroneous. Or, the plotting failed due to an omission of essential tag.	Correct erroneous part at the computer side.
0601	W # OF PARAM. ERROR	The number of parameters of TIFF data tag is wrong.	
0602	W PARAM._RANGE_ERR	The parameter value of TIFF data tag exceeds the supported range.	
0603	- (No error memo)	Data is ignored, because there is no effective plotting data in TIFF data.	Check the computer side if effective plotting data is transferred.
0700	- (No error memo)	The plotting failed due to an omission of essential record in the CALS format.	Correct erroneous part at the computer side.

■Engine warning

Description : This error may occur when image data is transferred from the controller to the engine for printing.

The drawing on which this error occurred may not be printed correctly because image data for printing is not transferred correctly.

Measure : If an error occurs successively, turn the power off and on. If the device does not recover from this error after turning the power off and on, please notify your dealer or our service center of the displayed error message and error condition.

W E 5 6 E - x x x x

xxxx: Error code

Error code	Description
9001 to 900F	Hardware chip error (Device transfer error)
9021 to 90FF	Hardware chip error (Operation failure)

■Main warning

Description : There is any problem in the data transmitted from the controller or computer.

Measure : Take measure according to an error code by referring to the following table.

W F 0 6 D - x x x x

xxxx: Error code

Error code	Description	Measure
0801	Faulty spool file	Turn off and on the power. If this error occurs frequently though the power is turned off and on, please inform our service center or sales agent of the error message displayed and error situation.
0838	PDL cannot be judged from data	Transmitted data may be faulty, if this error occurred in specific data. If the error occurred in the data that was outputted normally so far, please inform our service center or sales agent of the error message displayed and error situation.

Service Call Errors

Description : This error message may appear if an unrecoverable hardware or firmware failure occurs in the device.

In this case, you need call a service person to take measures.

Measure : If the device does not recover from this error after turning the power off and on, please notify your dealer or our service center of the displayed error message and error condition.

■Serial number not set

```
E SET THE S / N
```

Description : This error message may appear if the serial number checked at powering on is not specified.

■Engine error

```
E ENGINE x x x x
POWER OFF / ON
```

xxxx: Error code

Description : This error message may appear if the engine of the device is faulty.

■System error

```
E FFFF - FFFF
POWER OFF / ON
```

Description : This error message may appear if an unrecoverable and exceptional system error occurs in the controller of the device.

■Controller errors

Description : This error message may appear if an unrecoverable and fatal error occurs in each program module provided on the controller of the device.

(1) Error in PDL module

E F 0 6 4 - x x x x POWER OFF / ON	xxxx: Error code
---------------------------------------	------------------

Error code	Description
0380 to 039F	Program error
0A80 to 0A90	

(2) Error in engine control module

E E 5 6 E - x x x x POWER OFF / ON	xxxx: Error code
---------------------------------------	------------------

Error code	Description
0111 to 01FF	Program error
0201 to 02FF	
1000 to 1FFF	
0301 to 03FF	Hardware chip error
0401 to 04FF	Hard disc error
0501 to 05FF	Engine communication error
0601 to 06FF	Scanner communication error

(3) Error in operation module

E EF70 - x x x x
POWER OFF / ON

xxxx: Error code

Error code	Description
0101	Program error
1000 to 1FFF	

(4) Error in main module

E F06D - x x x x
POWER OFF / ON

xxxx: Error code

Error code	Description
0101	Program error
0111 to 01FF	
0201 to 02FF	
1000 to 1FFF	
0301 to 03FF	NVRAM error
0401 to 04FF	Hard disc/RAM disc error
2000 to 2FFF	Hardware configuration error

(5) Error in setup module

E F375 - x x x x
POWER OFF / ON

xxxx: Error code

Error code	Description
0101	Program error
1000 to 1FFF	
0301 to 03FF	NVRAM error
0401 to 04FF	Setup control file error

(6) Error in panel control module

E F 0 6 E - x x x x
POWER OFF / ON

xxxx: Error code

Error code	Description
0201	Program error
1000 to 1FFF	

(7) Error in spool module

E F 3 7 5 - x x x x
POWER OFF / ON

xxxx: Error code

Error code	Description
1001	Storage access error

Error log

Each time an error or warning occurs in the device, it is displayed on the control panel and also the error log information is saved in the internal memory.

The error log information saved in the internal memory includes additionally the time when an error occurred, and therefore you can confirm the error log using the “ERROR PRINT” on the function menu. This error log information is saved even after the power was turned off.

Classification of Error/Warning

The type of error/warning is classified as follows:

- (1) Classification: E (Service Call)
An unrecoverable error that needs the service person's intervention.
- (2) Classification: O (Operator Call)
An error that the operator can take actions to fix.
- (3) Classification: W (Warning)
A warning, such as being low on consumables, or that a data error occurred.

Format of Message

Each error/warning message to be logged if an error or warning occurs classifies one character (+ space) at the top of the message as the error/warning identifier.

The log message is composed of alphanumeric characters and thus it does not necessarily match the message displayed on the control panel.

The error/warning message registered as log information is prepared in the format mentioned below.

Log Registration Format

An error or warning displayed on the LCD is registered as log information in the following format.

Case 1 “yyyy/mm/dd hh:mm:ss a bbbb-cccc”
Case 2 “yyyy/mm/dd hh:mm:ss a ssssssss cccc”
Case 3 “yyyy/mm/dd hh:mm:ss a ssssssss”

yyyy/mm/dd	year/month/day
hh:mm:ss	hour:minute:second
a	Error/warning identifier (common to LC display)
bbbb-	Error classification (hexadecimal notation)
cccc	Error code (hexadecimal notation may be omitted)
sssssss	Optional alphanumeric message (may be omitted)

*Log example

“2007/05/24 12:31:55 E ENGINE 2030”
Error number:2030=Power supply failure

Type of Error Log

The errors are classified as follows.

The following log examples show the information saved in the log file.

Service Call Error (Classification: E)

Description : An unrecoverable error that needs service person's intervention.

Cause : Hardware or firmware is faulty.

Measure : If the device does not recovered from this error after turning the power off and on, please notify your dealer or our service center of the displayed error message and error condition.

*Log example of hard disc error
“E E56E-0401”

Operator Call (Classification: O)

Description : An error that the operator can fix.

Cause : No paper, no toner or paper jams.

Measure : Fix the cause to restore the device to its normal state.

*Log example of door open
“O DOOR2 open”

Warning (Classification: W)

Description : A warning state such as being low on consumables, or that a data error occurred.

Cause : A consumable is almost used up, or any failure in the environment, settings, or data occurred.

Measure : Take appropriate measures to remove the cause.

*Log example in case of HPGL format error

“W DATA 0201”

Error Log Classification Table

Message	Classification	Description	Measure
E xxxxxxxx (Error)	Service call error	An unrecoverable error needs a service person's intervention.	If the device does not recover from this error after turning the power off and on, please notify your dealer or our service center of the displayed error message and error condition.
O xxxxxxxx (Operator Call)	Operator call	An error that the operator can fix.	Remove the cause to restore the device to its normal state. Take measures according to the guidance message displayed on the control panel.
W xxxxxxxx (Warning)	Warning	A consumable almost used up, or problems in the environment, settings, or data was detected.	Remove the cause of each failure.

Troubleshooting for ethernet

■When no communication can be made

Cause	Checking method	Corrective measure
No Power	<ul style="list-style-type: none"> - Check if the power switch is turned on. - Check if the power cable is connected correctly. 	<ul style="list-style-type: none"> - Turn on the power switch. - Connect the power cable correctly.
LAN cable is not connected correctly	<ul style="list-style-type: none"> - Check if the cable is connected to the connector securely. 	<ul style="list-style-type: none"> - Connect the cable completely. - If the cable is connected, disconnect and reconnect it.
LAN cable is disconnected	<ul style="list-style-type: none"> - Check if communication can be made when the LAN cable is connected to another host or printer. - Check if the ping command to the device is effective. 	<ul style="list-style-type: none"> - Use another LAN cable.
Network system is faulty	<ul style="list-style-type: none"> - Check if the LP-1020 operates by the ping command transmitted from the host. 	<ul style="list-style-type: none"> - Please consult a system administrator.
IP address is not specified correctly	<ul style="list-style-type: none"> - Check if the setting value of the device is the same as the IP address assigned by a system administrator. 	<ul style="list-style-type: none"> - Specify the correct IP address.
Subnet mask is not set correctly	<ul style="list-style-type: none"> - Check if the setting value of the device is the same as the subnet mask assigned by a system administrator. 	<ul style="list-style-type: none"> - Specify the correct subnet mask.
Routine table is not set correctly	<ul style="list-style-type: none"> - Check if the setting value of the device is the same as the IP router address assigned by a system administrator. - Check if the address in the network system to be connected is correct. 	<ul style="list-style-type: none"> - Specify the correct IP router address. - Specify the correct network address to be connected. (If it is unknown, set default route value 000.000.000.000.)
Connections are made, exceeding the maximum number of simultaneous connections of the device (Max. 10 users)	<ul style="list-style-type: none"> - Check if multiple hosts use the device simultaneously. 	<ul style="list-style-type: none"> - Adjust the number of users that use the device simultaneously.
IP address already used by other equipment is set. (Duplicated use of IP address)	<ul style="list-style-type: none"> - Ask the system administrator for confirmation. 	<ul style="list-style-type: none"> - Specify the correct IP address.
IP address that was used immediate-previously by other equipment is set	<ul style="list-style-type: none"> - Ask the system administrator for confirmation. 	<ul style="list-style-type: none"> - Because the address of original equipment is cached in the host or relay units such as switches, clear the cache table in such units.

Cause	Checking method	Corrective measure
Protocol (xpt, ftp, lpr) is not specified	- Check if the protocol (xpt, ftp, lpr) setting is made active at the device side.	- Make the protocol setting active.
The printer name of lpr is not correct. (When lpr protocol is used)	- Check if the printer name matches between host side and device side.	- Specify correct printer name. (Ask the system administrator for confirmation, because a setting method is different between UNIX and Windows.)
The user name of ftp is not correct. (When ftp protocol is used)	- Check if the user name designated by the host matches the user name designated by the device.	- Use the correct user name, or change the user name at the device side.
The password of ftp is not correct. (When ftp protocol is used)	- Check if the password designated by the host matches the user name designated by the device (user name = password on device side).	- Use the correct password, or change the user name at the device side.
xpt TCP port setting is not correct	- Check if the TCP port address matches between host side and device side.	- Specify correct xpt port address.
Network setting (such as TCP protocol) at the host side is not correct	- Ask the system administrator for confirmation.	- Make correct network setting at the host side. (Because a setting method is different depending on the host unit, ask the system administrator for confirmation.)

■When output results are faulty

Cause	Checking method	Corrective measure
Binary designation is not made (in case of ftp connection)	- Check if the data is transmitted after the ftp command (bin) was issued.	- Issue the bin command and then transmit the data to the device. (However, bin may not be issued even if the bin is designated depending on the host unit. In such a case, fix the setting to bin at the device side.)

If "BOTTLE MAINT. STARTS" appears

In order to prevent the waste toner from accumulating unevenly in the waste toner bottle, this device provides a maintenance function that taps the waste toner bottle to level the waste toner when the specified amount of print is executed.

Though the waste toner maintenance function has been set in the factory so that it starts automatically when the specified amount of print is executed, you can change the setting so that a message to prompt you to perform the maintenance appears. In this case, the maintenance does not start unless the key is pressed. (⇒ page 6-6)



■If "MANUAL" is set

The message shown below appears to prompt you to perform the maintenance of waste toner bottle.

If the  key is pressed, the message is switched and the maintenance starts.

The maintenance is performed for about 30 seconds, and taps will be heard during the operation.

BOTTLE MAINT. STARTS
PRESS ENTER KEY

 Press the  key.

BOTTLE IS TAPPED .
WAIT A MOMENT .

■If "AUTO" is set

The maintenance of waste toner bottle starts automatically, and the following message appears on the screen.

BOTTLE IS TAPPED .
WAIT A MOMENT .

When a print error occurs

This section explains how to solve print quality problems. Take appropriate measures according to the symptoms.

■ Measures to solve print quality problems

Symptom	Cause	Corrective measure
Plotting is light/dark	-----	Adjust the density. ⇒ Page 6-5
Plotting is locally deleted	The type of loaded paper does not match the type of paper specified on the panel.	Replace the paper, or change the setting. ⇒ Page 2-16 or 7-2
	Paper contains moisture.	Cut the end of the rolled paper and retry plotting. ⇒ Page 14-11
	The recommended paper is not used.	Use our recommended paper. ⇒ Page 1-7
Plotting is locally streaked	Process cartridge reached its life.	Replace the process cartridge. ⇒ Page 2-28



- ◆ When there is a space between drawings, the end of the roll paper can be cut automatically before the next plotting.
⇒ “EDGE CUT TIMER” on page 6-4

When there is an abnormal sound

If you hear an abnormal sound, contact your dealer or our service center.

Note

- ◆ In order to prevent the waste toner from accumulating unevenly in the waste toner bottle, this device provides the maintenance function that taps the waste toner bottle at the definite interval to level the waste toner. (⇒ page 14-36)
Taps will be heard during the maintenance of waste toner, but this is not a problem.

Appendix

Appendix covers basic specifications, configuration, menu structure, and commands of the LP-1020 series plotters.

The contents of Appendix are as follows:

Basic specifications

Menu structure

Command List

Basic specifications

Plotter Specification

■ Basic Specifications of Plotter

(1/2)

Items	Specifications/Functions	
	LP-1020	LP-1020L
Recording method	Electrophotographic method (LED exposure)	
Developing method	Dry development (one component)	
Type of photosensitive element	OPC	
Fusing system	Heat roller	
Resolution	600 dpi	
Continuous print speed	A0 (ortrait) : 3.4 sheets/min A1 (portrait) : 4.6 sheets/min A2 (portrait) : 6.2 sheets/min A3 (portrait) : 8.0 sheets/min A3 (landscape) : 8.8 sheets/min A4 (landscape) : 10.6 sheets/min	
Paper feed configuration/ Delivery direction	Max. triple rolls, manual feeding/Front delivery	
Type of paper	Plain paper Recycled paper Tracing paper Mat film	
Paper size	Rolled paper (width) A0/A1/A2/A3, 36" /24" /18" /12" Cut paper: A0/A1/A2/A3	
Max. output length	2.5 m (98.4 inches)	10 m (393.7 inches)
Warming up time	4 minutes or less	8 minutes or less
First prin	Within 28 seconds/A0 drawing	
Plotting guarantee area (Rolled paper only)	All areas except margin 5 mm (0.2 inches) at top/margin 12 mm (0.47 inches) at bottom/margin 3 mm (0.12 inches) on each side	
Data format	D-SCAN, HP-GL, HP-GL/2, HP RTL, TIFF, CALS	
HDD	40GB (optional)	40GB
Interface	Standard: Ethernet (10/100BASE) Optional: USB2.0, Centronics	Standard: Ethernet (10/100BASE) USB2.0, Centronics
Network protocol	TCP/IP (ftp, lpr, xpt)	

(2/2)

Items	Specifications/Function	
	LP-1020	LP-1020L
Noise	In operation : 61dB (A) or less (continuous sound) In standby : 53dB (A) or less	
Calorific value	4860 kJ or less	
Power supply voltage	120 V AC \pm 10% 230 V AC \pm 10%	
Frequency	50/60 Hz \pm 1Hz	
Power consumption	In operation : 1350 W or less In standby : 45 W or less (in Power Save mode)	
External dimensions	1154 (W) \times 552 (D) \times 1063 (H) mm 45.5 (W) \times 21.7 (D) \times 41.9 (H) inches	
Weight	215 kg or less	
Temperature/humidity range in use of plotter	15 to 35° C/20 to 80%RH (no dew condensing) Humidity should be 48% or less when temperature is 35° C, or temperature should be 28° C or less when humidity is 80%RH.	
Temperature/humidity range in nonuse of plotter	-5 to 40° C/10 to 90%RH (no dew condensing)	
Installation space	2054 (W) \times 1662 (D) \times 1500 (H) mm 80.9 (W) \times 65.5 (D) \times 59.1 (H) inches	
Maintenance space	2554 (W) \times 2052 (D) \times 2000 (H) mm 100.6 (W) \times 80.8 (D) \times 78.8 (H) inches	

Menu structure



◆ The menu structure shown below is prepared on the basis of the factory settings of the plotter.

[SETUP] MENU

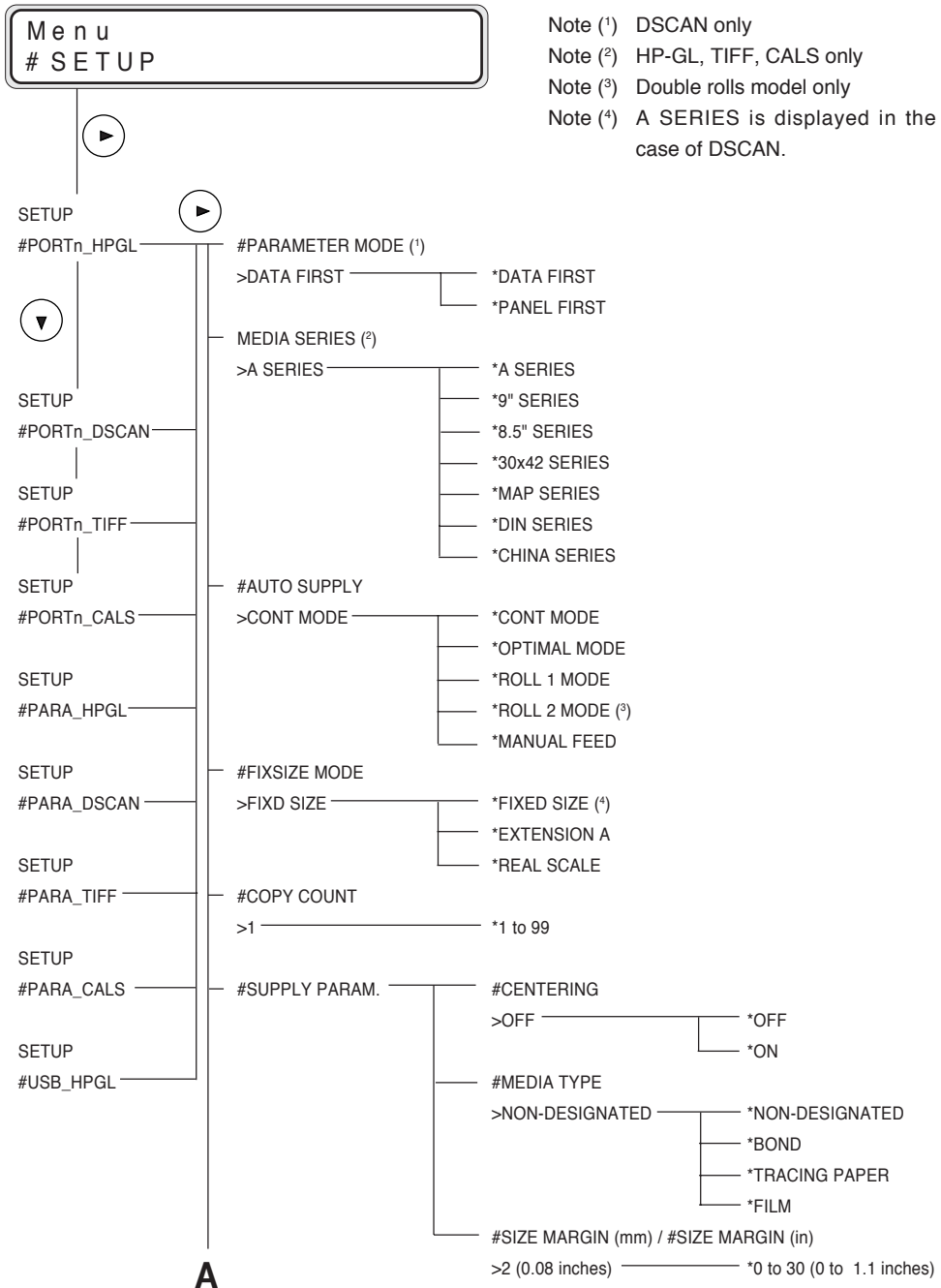

- Note (1) DSCAN only
- Note (2) HP-GL, TIFF, CALS only
- Note (3) Double rolls model only
- Note (4) A SERIES is displayed in the case of DSCAN.

Note ⁽⁵⁾ TIFF, CALS only

Note ⁽⁶⁾ HP-GL only

A

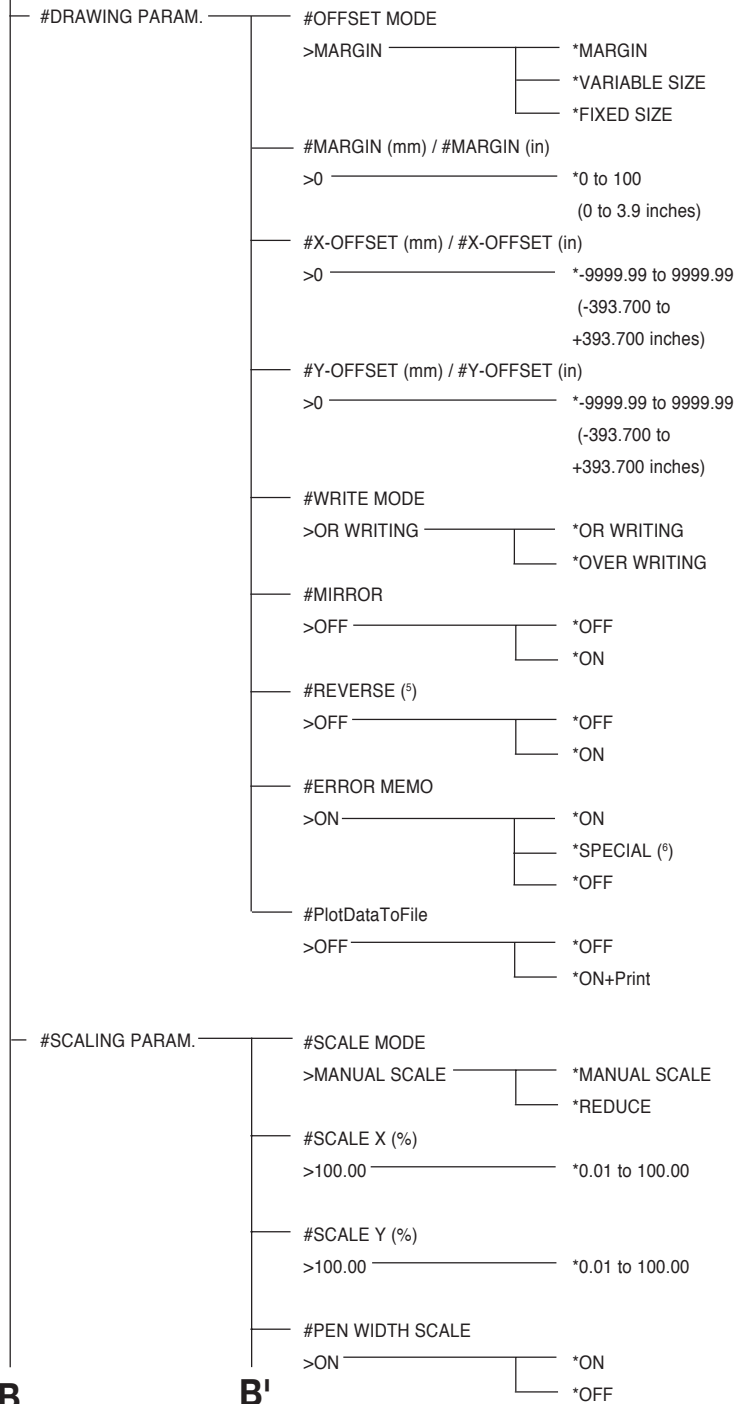

B

B'

Note (7) HP-GL, TIFF, CALS only

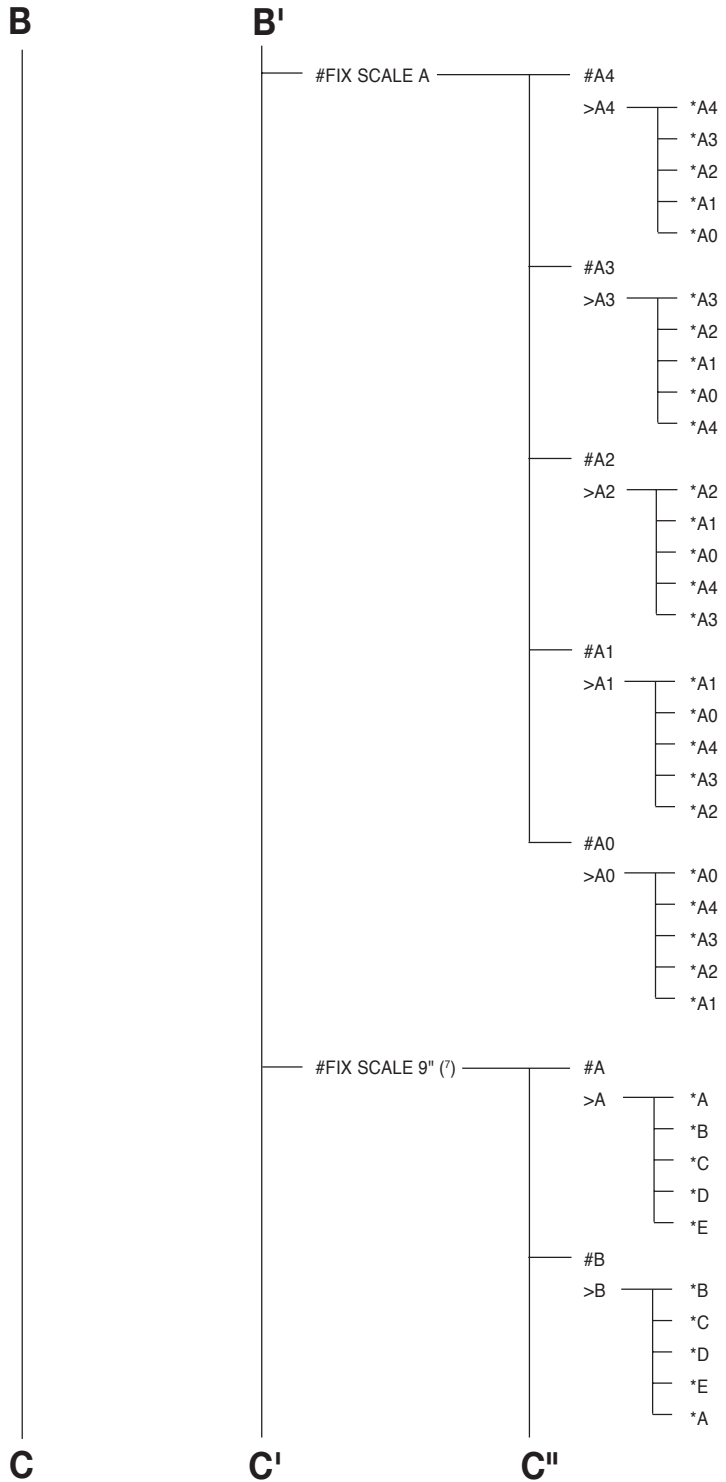

Note (?) HP-GL, TIFF, CALS only

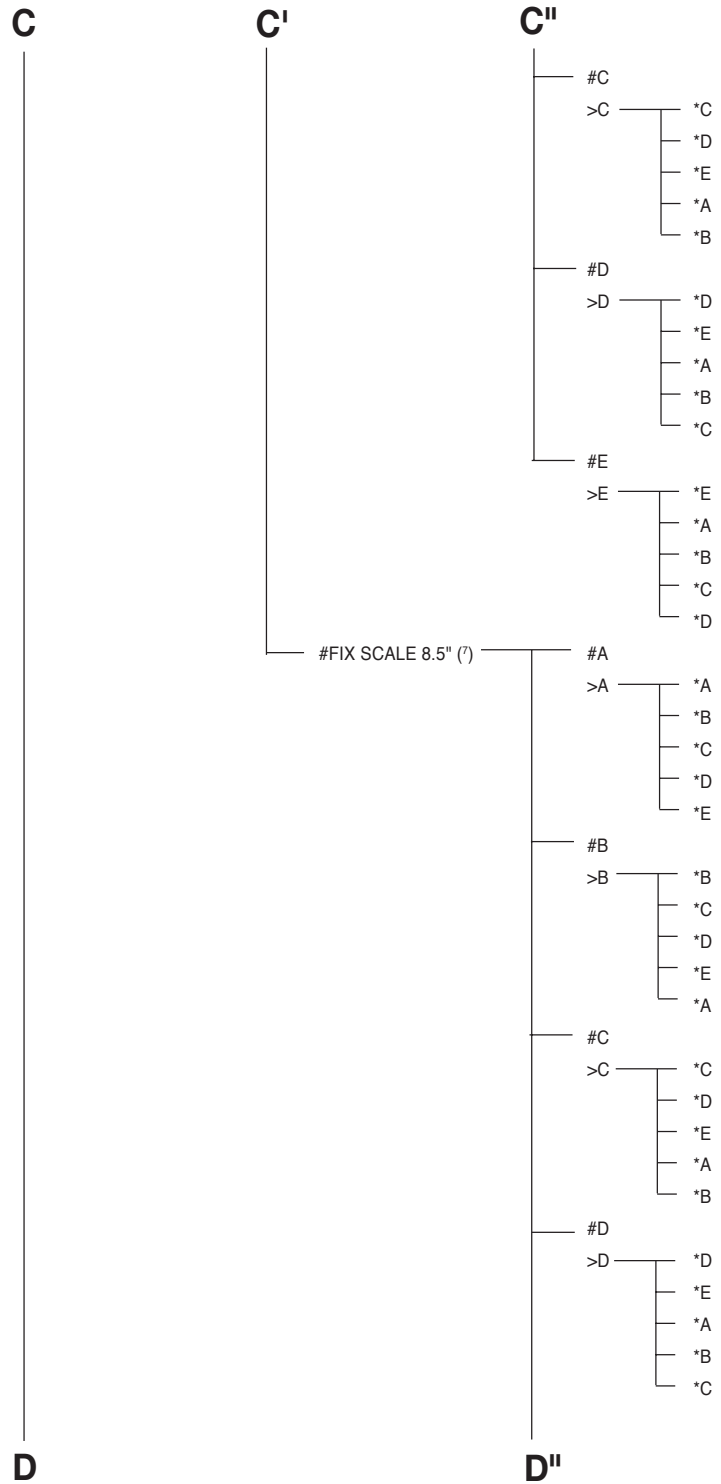

Note (8) HP-GL, DSCAN only

Note (9) HP-GL only

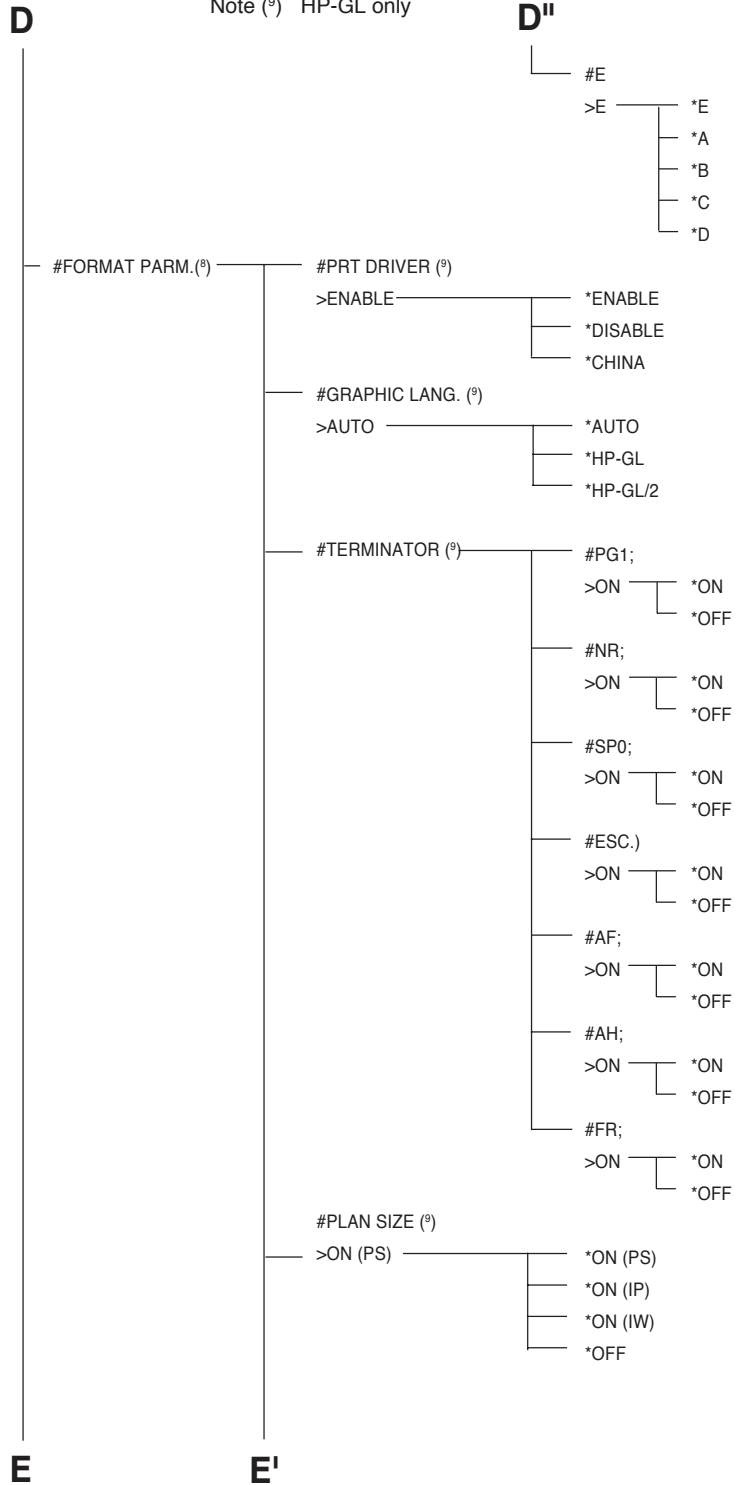

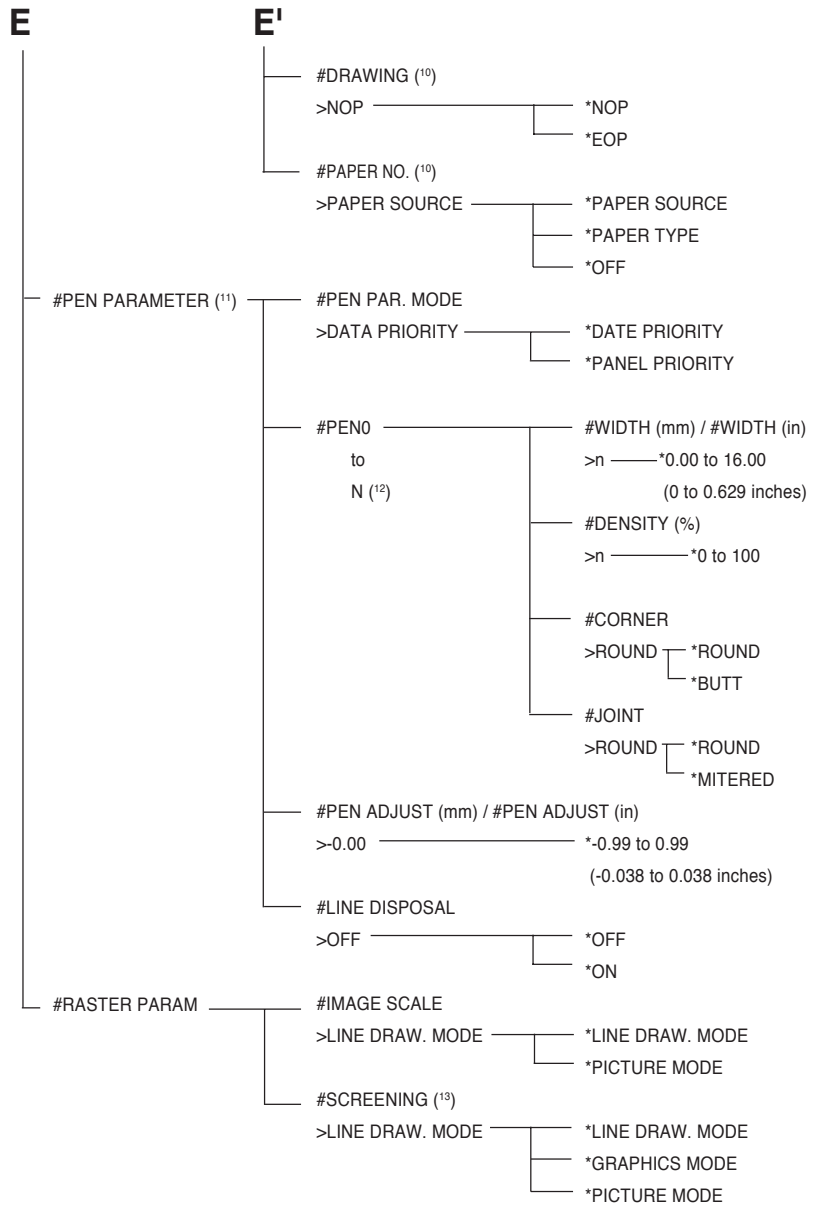

Note ⁽¹⁰⁾ DSCAN only

Note ⁽¹¹⁾ HP-GL, DSCAN only

Note ⁽¹²⁾ HP-GL is 0 to 15

DSCAN is 1 to 32

Note ⁽¹³⁾ HP-GL, DSCAN, TIFF only

[DEVICE] MENU

MENU
DEVICE

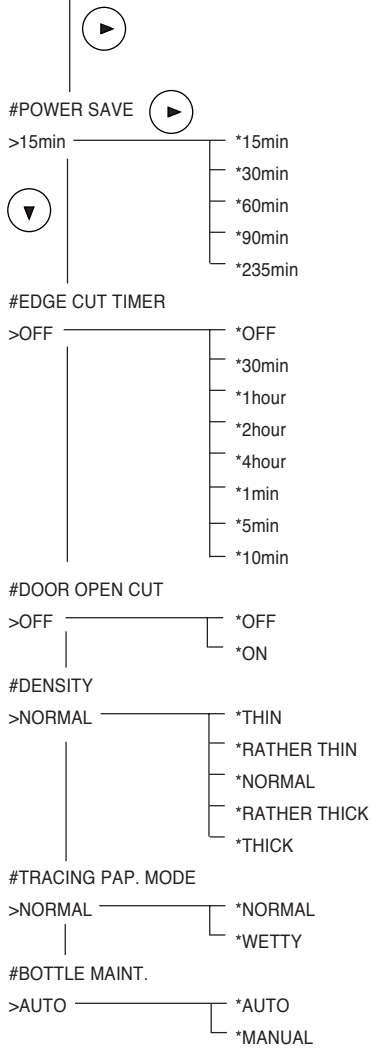

[PAPER] MENU

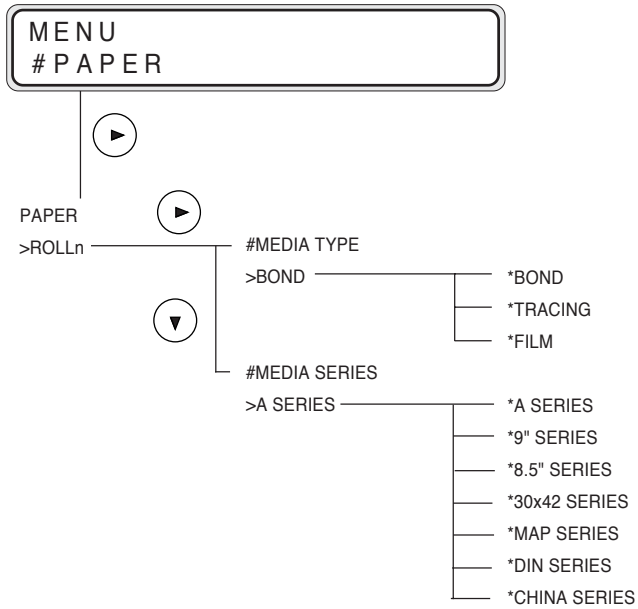

[FUNCTION] MENU

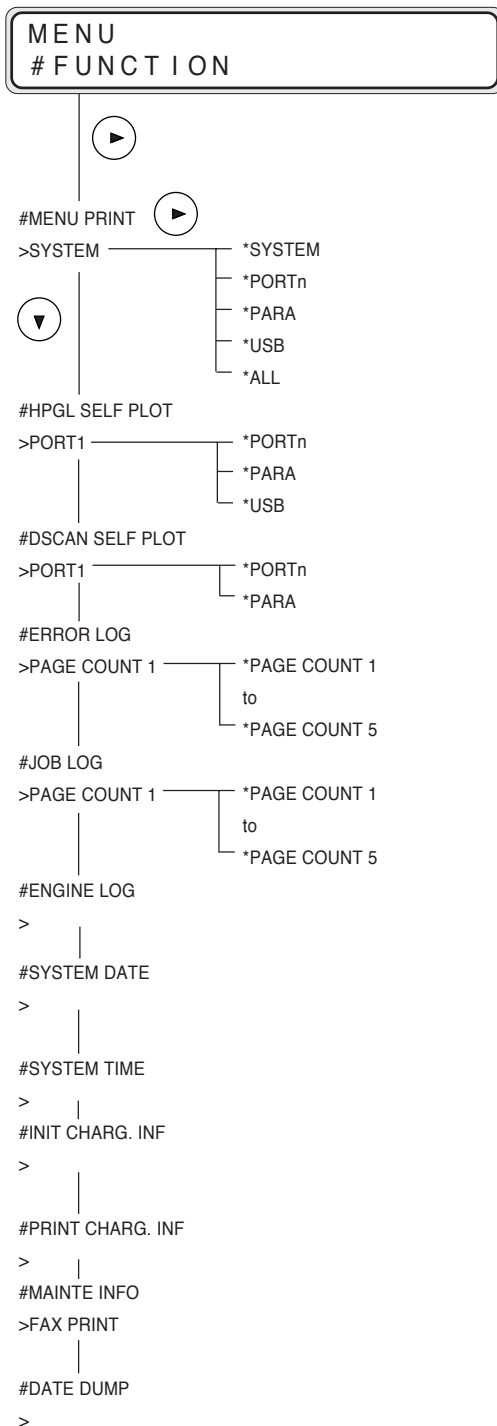

[PROTOCOL] MENU

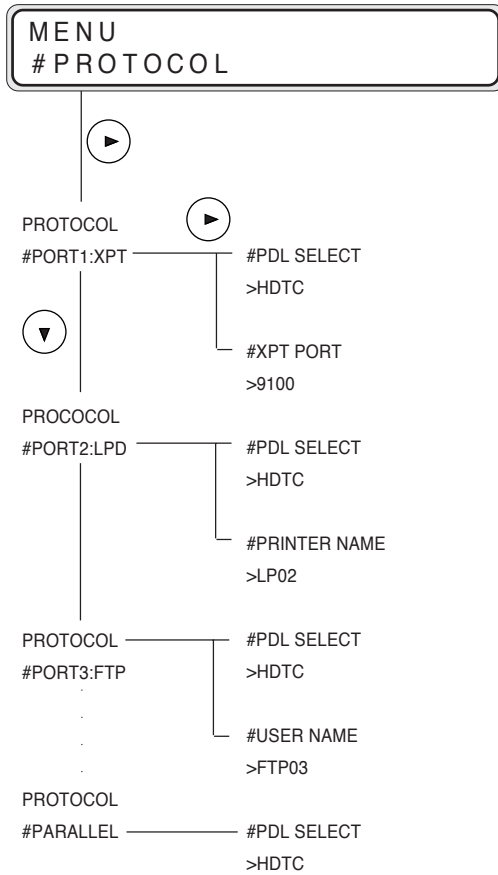

[RESET] MENU

MENU
R E S E T



#SYSTEM RESET

>



#PORT RESET

>PORT1

[SYSTEM] MENU

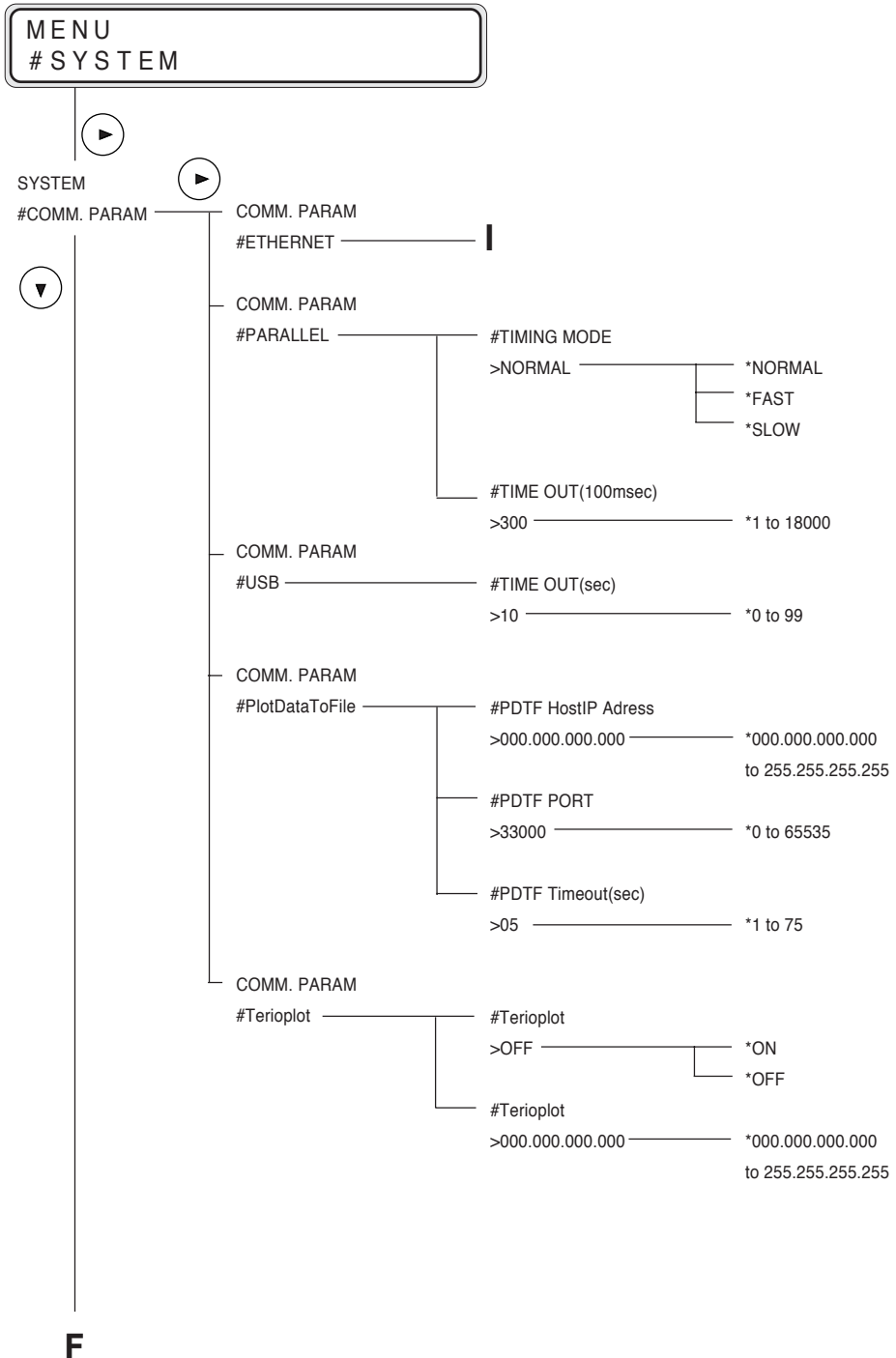

F

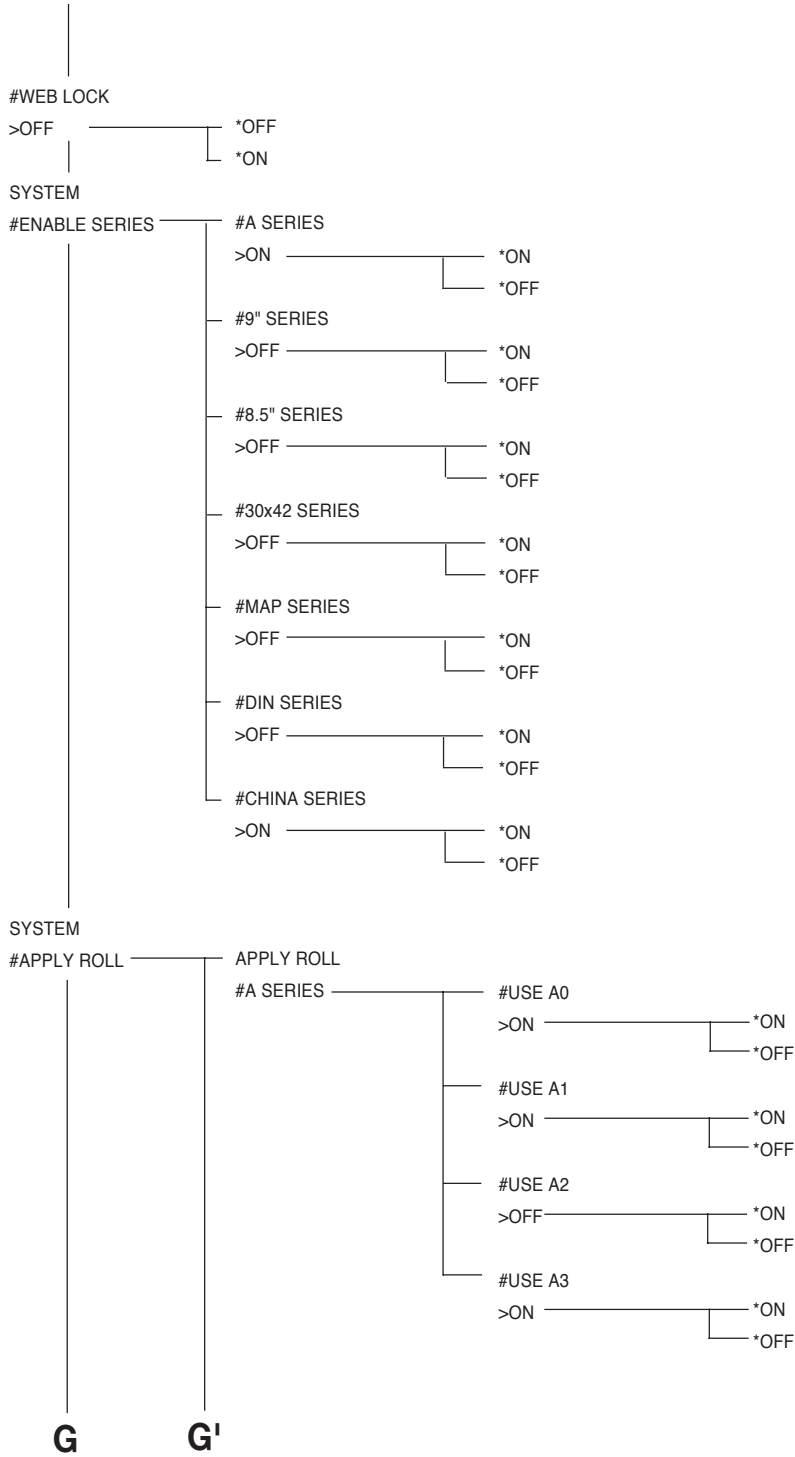

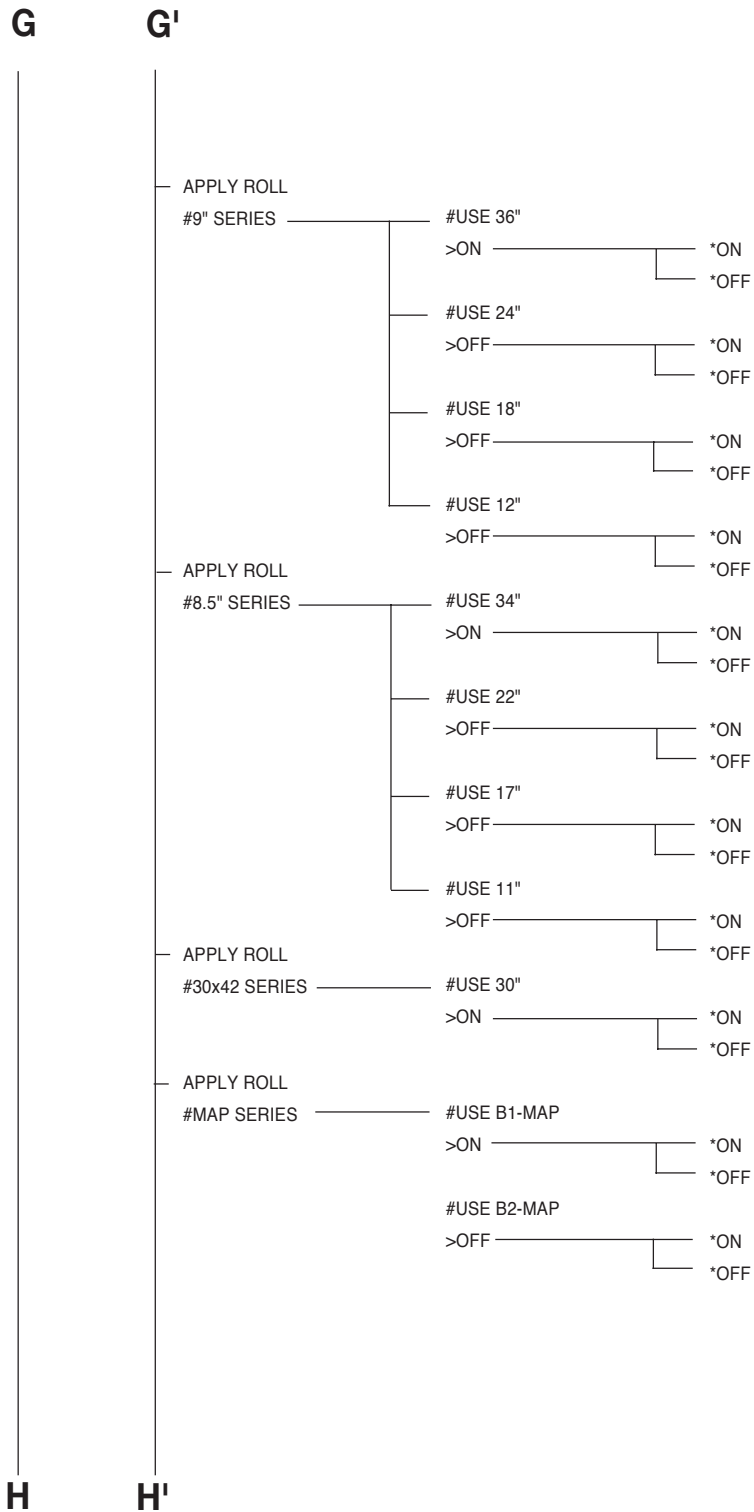

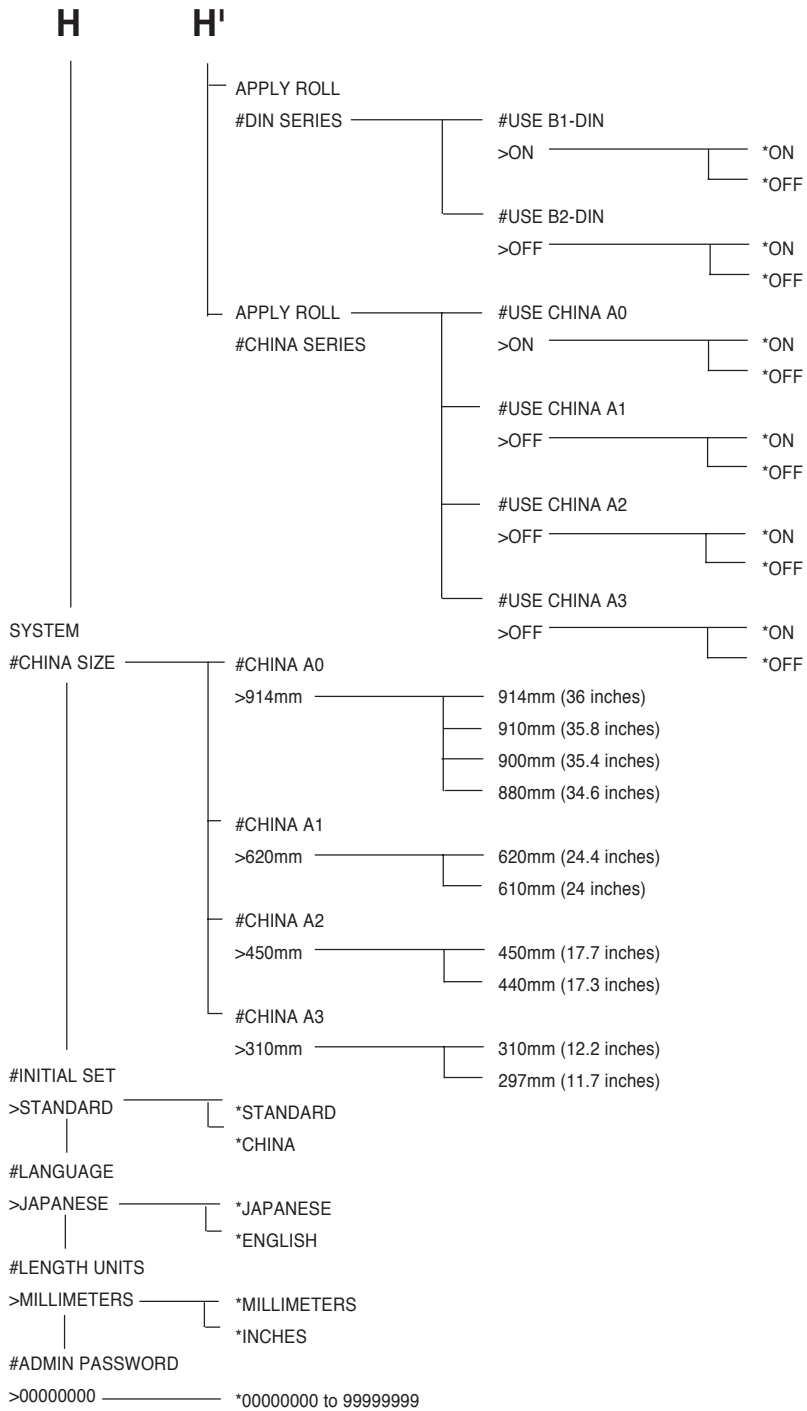

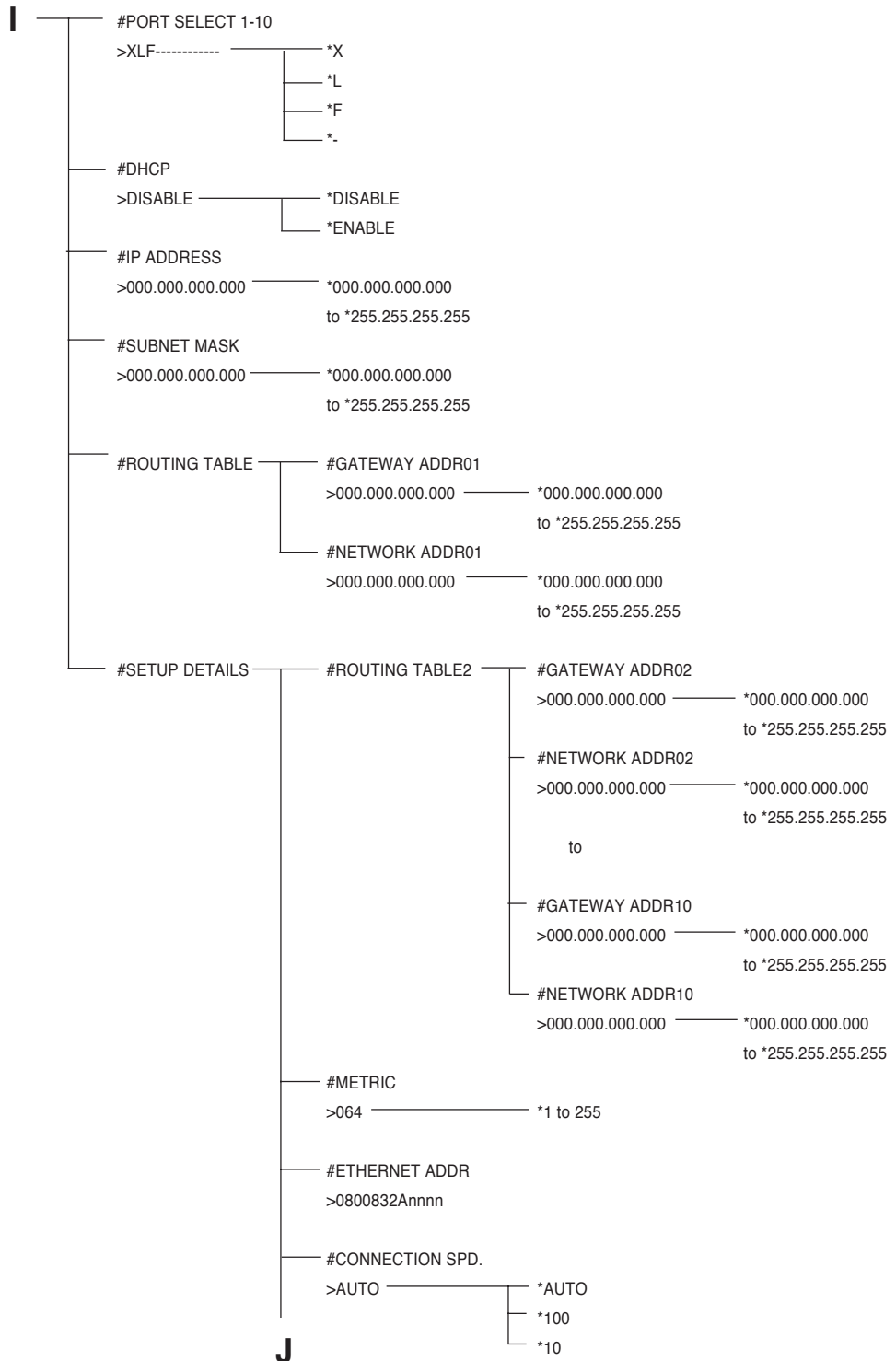

J

Appendix

J

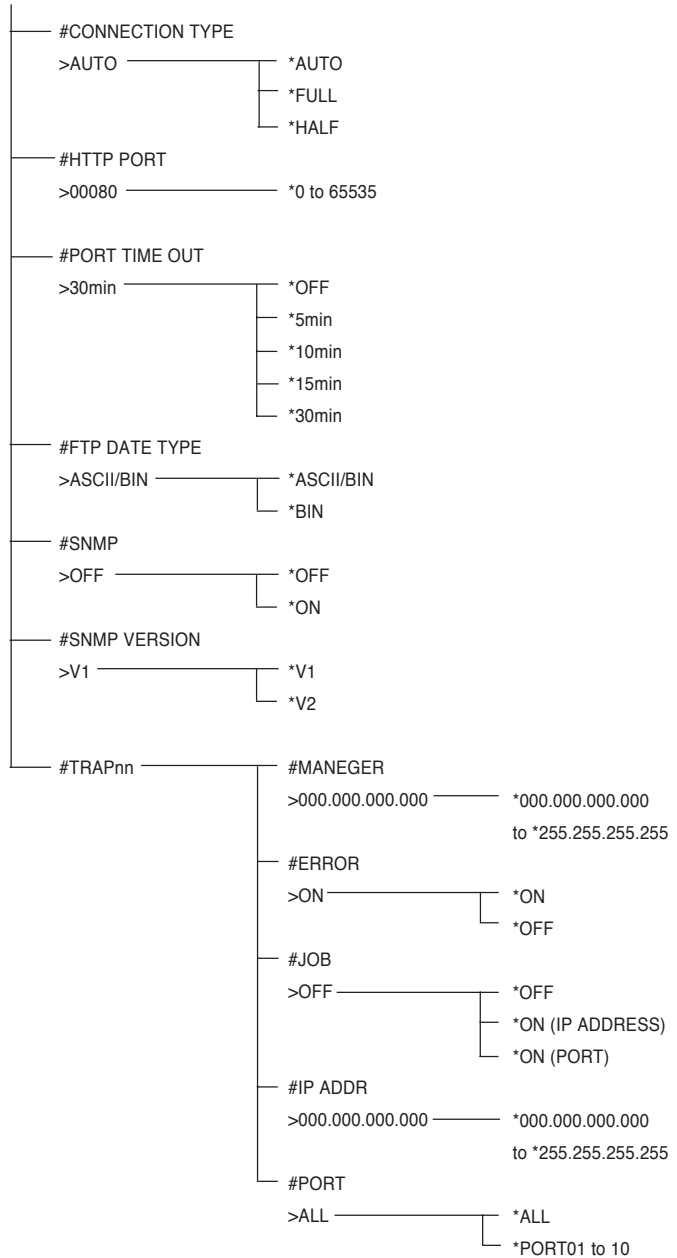

Command list

HP-GL,HP-GL/2 Device Control Command List

Symbols in the following table denote as follows:

- : Denotes the command supported by this plotter.
- : Denotes that only part of the command function is supported by this plotter.
- × : Denotes the command not supported by this plotter.

If a command not supported by this plotter is received, that command is ignored.

If a command not listed in the following table is received, the command error occurs.

Command	Function	Support
ESC.(ESC.Y	Plotter ON instruction	○
ESC.) ESC.Z	Plotter OFF instruction	○
ESC.@	Plotter configuration set instruction	× ⁽¹⁾
ESC.A	Plotter model number output instruction	× ⁽¹⁾
ESC.B	Buffer space output instruction	× ⁽¹⁾
ESC.E	Advanced error number output instruction	× ⁽¹⁾
ESC.H	Handshake mode 1 set instruction	× ⁽¹⁾
ESC.I	Handshake mode 2 set instruction	× ⁽¹⁾
ESC.J	Device control instruction abort instruction	× ⁽¹⁾
ESC.K	Plotting abort instruction	× ⁽¹⁾
ESC.L	Logical I/O buffer size output instruction	× ⁽¹⁾
ESC.M	Output set instruction	× ⁽¹⁾
ESC.N	Output mode, handshake mode advanced set instruction	× ⁽¹⁾
ESC.O	Advanced status output instruction	× ⁽¹⁾
ESC.P	Handshake mode standard set instruction	× ⁽¹⁾
ESC.Q	Monitor mode set instruction	× ⁽¹⁾
ESC.R	Reset instruction	× ⁽¹⁾
ESC.S	Buffer size output instruction	× ⁽¹⁾
ESC T	Buffer size set instruction	× ⁽¹⁾
ESC.U	End of flash buffer	× ⁽¹⁾

- ⁽¹⁾ Because serial communication is not supported.
- ⁽²⁾ Only the binary raster data is effective. Vector data and multi-value raster data are effective only in the color overlap mode.
- ⁽³⁾ The fonts of font number specified by the AD or SD command are plotted with the fonts of the font number specified by the CS command shown in the following table.
- ⁽⁴⁾ Recognized as EOF.

HP-GL,HP-GL/2 Device Plotting Command List

Symbols in the following table denote as follows:

- : Denotes the command supported by this plotter.
- : Denotes that only part of the command function is supported by this plotter.
- × : Denotes the command not supported by this plotter.

If a command not supported by this plotter is received, that command is ignored.

If a command not listed in the following table is received, the command error occurs.

(1/3)

Classifica- tion	Command	Function	Support
Drawing information	DF	Standard set instruction	○
	IN	Initial set instruction	○
	IP	Scaling point set instruction	○
	SC	Scale instruction	○
	RO	Coordinate system rotate instruction	○
	JW	Window set instruction	○
	PS	Drawing size set instruction	○
	IR	Relative scaling point set instruction	○
	BP	Drawing information set instruction	○
	QL	Drawing quality set instruction	○
RP	Replot instruction	×	
Pen attributes	SP	Pen number select instruction	○
	PC	Pen color set instruction	○
	PW	Pen width set instruction	○
	WU	Pen width mode set instruction	○
	LT	Line type select instruction	○
	UL	Line type user definition	○
	LA	Line end connection type select instruction	○
	NP	Number of pens set instruction	○
	CR	Color range set instruction	○
GP	Pen group set instruction	×	
SG	Pen group select instruction	×	
Vector instructions	PA	Absolute coordinate move instruction	○
	PR	Relative coordinate move instruction	○
	PD	Pen down instruction	○
	PU	Pen up instruction	○
	EA	Absolute coord. rectangle plot instruction	○
	ER	Relative coord. rectangle plot instruction	○
	AA	Absolute coord. arc plot instruction	○
	AR	Relative coord. arc plot instruction	○
	CI	Circle plot instruction	○
	EW	Fan-shape plot instruction	○
	AT	Absolute coord. 3-point arc plot instruction	○
	RT	Relative coord. 3-point arc plot instruction	○
	CT	Arc resolution mode select instruction	○
	TL	Division length set instruction	○
	XT	X-axis division plot instruction	○
	YT	Y-axis division plot instruction	○
	PE	Encryption plot instruction	○
	BZ	Absolute coord. Bezier plot instruction	○
BR	Relative coord. Bezier plot instruction	○	

(2/3)

Classification	Command	Function	Support
Filling attributes	FT	Filling style set instruction	○
	PT	Hatch interval set instruction	×
	AC	Filling pattern base point set instruction	○
	RF	Filling pattern define instruction	○
	MC	Color overlap control instruction	● ⁽²⁾
	TR	Transparency mode select instruction	○
	UF	Hatch filling pattern define instruction	×
Filling instructions	SV	Vector filling pattern style set instruction	×
	RA	Absolute coordinate rectangle fill instruction	○
	RR	Relative coordinate rectangle fill instruction	○
Polygon instructions	WG	Fan-shape fill instruction	○
	PM	Polygon mode set instruction	○
	EP	Polygon frame plot instruction	○
Character attributes	FP	Polygon fill instruction	○
	SI	Absolute character size set instruction	○
	SR	Relative character size set instruction	○
	DI	Absolute character direction set instruction	○
	DR	Relative character direction set instruction	○
	DV	Character writing direction set instruction	○
	ES	Character spacing set instruction	○
	SL	Italic character set instruction	○
	LO	Text origin set instruction	○
	DT	Text terminator set instruction	○
	CA	Auxiliary character-set set instruction	○
	CS	Standard character-set set instruction	○
	SA	Auxiliary character-set select instruction	○
	SS	Standard character-set select instruction	○
	AD	Auxiliary character font set instruction	● ⁽³⁾
	SD	Standard character font set instruction	● ⁽³⁾
	LM	Character code select instruction	○
	TD	Control character plotting set instruction	×
	CM	Character code, undefined character set instruction	×
	DS	Character slot set instruction	×
	IV	Character slot assign instruction	×
	CC	Arc character resolution set instruction	×
	CF	Font filling style set instruction	×
	FI	Standard font ID set instruction	×
	FN	Auxiliary font ID set instruction	×
	SB	Bit map font set instruction	×
	Character instructions	LB	Text plot instruction
BL		Text store instruction	○
PB		Stored text plot instruction	○
CP		Number of characters move instruction	○
SM		Symbol mode set instruction	○
DL		User character register instruction	○
	UC	User character plot instruction	○

Classification	Command	Function	Support
Advanced instructions	NR	Not ready instruction	○
	AF	One page paper feed instruction	●
	AH	Half page paper feed instruction	● (4)
	FR	One frame paper feed instruction	● (4)
	PG	Plotting end instruction	○
	MG	Message display instruction	×
	IM	Error mask instruction	○
	EC	Cutter control instruction	○
	AP	Automatic pen status set instruction	×
	AS	Pen acceleration set instruction	×
	FS	Pen pressure set instruction	×
	VS	Pen speed set instruction	×
	MT	Paper type set instruction	×
	ST	Sorting set instruction	×
PP	Pixel position select instruction	×	
Digitize instructions	DC	Digitize mode cancel instruction	×
	DP	Digitize mode activate instruction	×
Output instructions	OA	Pen position, status output instruction (Plotter unit)	×
	OC	Pen position, status output instruction (User unit)	×
	OD	Digitize position, status output instruction	×
	OE	Error output instruction	×
	OF	Plotter unit output instruction	×
	OH	Hard clip limit output instruction	×
	OI	Model identification No. output instruction	×
	OL	Stored text information output instruction	×
	OO	Option output instruction	×
	OP	Scaling point output instruction	×
	OS	Status output instruction	×
	OT	Carousel type output instruction	×
OW	Window output instruction	×	

(1) Because serial communication is not supported.

(2) Only the binary raster data is effective. Vector data and multi-value raster data are effective only in the color overlap mode.

(3) The fonts of font number specified by the AD or SD command are plotted with the fonts of the font number specified by the CS command shown in the following table.

(4) Recognized as EOF.

Font No. specified by AD, SD	Corresponding font No. by CS	Font No. specified by AD, SD	Corresponding font No. by CS	Font No. specified by AD, SD	Corresponding font No. by CS	Font No. specified by AD, SD	Corresponding font No. by CS
0	0	19	31	83	37	563	99
4	32	21	0	85	35	595	5
5	7	36	32	115	30	1611 (Kanji)	101 (Kanji)
6	34	37	35	147	38	1643 (Kanji)	101 (Kanji)
9	36	38	34	267	8		
11	6	39	33	277	0		
14	0	43	8	531	(Note 1)		

Note 1: Character set 531 corresponds to the user defined characters.

HP RTL Plotting Command List

Symbols in the following table denote as follows:

- : Denotes the command supported by this plotter.
- : Denotes that only part of the command function is supported by this plotter.
- × : Denotes the command not supported by this plotter.

If a command not supported by this plotter is received, that command is ignored.

If a command not listed in the following table is received, the command error occurs. (1/2)

Command		Function	Support
Name	Code		
Enter HP-GL/2 Mode	ESC % # B	Activates HP-GL/2 mode.	● (1)
Enter PCL Mode	ESC % # A	Activates PCL mode.	● (2)
Reset	ESC E	Performs resetting.	● (3)
Universal Exit Language/Start of PPL	ESC % # X	Starts PPL.	×
Apple Talk Configuration	ESC & b # W [bin data]	Communicates with Apple Talk Driver.	×
Configure Image Data	ESC * v # W [data]	Configures image data.	● (4)
Set Red Parameter	ESC * v # a A	Sets red parameter.	○
Set Green Parameter	ESC * v # b B	Sets green parameter.	○
Set Blue Parameter	ESC * v # c C	Sets blue parameter.	○
Assign Color Index	ESC * v # i I	Assigns color index number.	● (5)
Push/Pop palette	ESC * p # P	Pushes or pops up the palette.	● (6)
Source Raster Width	ESC * r # s S	Sets source raster width.	○
Source Raster Height	ESC * r # t T	Sets source raster height.	○
Move CAP Horizontal (Decipoints)	ESC & a # h H	Moves CAP horizontally (decipoints).	○
Move CAP Horizontal	ESC * p # x X	Moves CAP horizontally.	○
Move CAP Vertical	ESC * p # y Y	Moves CAP vertically.	○
Y Offset	ESC * b # y Y	Sets Y-direction offset.	○
Destination Raster Width	ESC * t # h H	Sets destination raster width.	○
Destination Raster Height	ESC * t # v V	Sets destination raster height.	○
Raster Line Path	ESC * b # l L	Sets raster line path.	○
Negative Motion	ESC & a # n N	Specifies a negative motion.	○
Set Graphics Resolution	ESC * t # r R	Sets graphics resolution.	○
Start Raster Graphics	ESC * r # a A	Shows the start of raster graphics.	○
End Raster Graphics	ESC * r C	Shows the end of raster graphics.	○
Transfer Raster Data by Plane	ESC * b # V [data]	Transfers raster data every plane.	○
Transfer Raster Data by Row/Block	ESC * b # W [data]	Transfers raster data every row/block.	○
Set Compression Method	ESC * b # m M	Sets a compression method.	○

Command		Function	Support
Name	Code		
Foreground Color	ESC * v # s S	Sets the RGB value of the specified index number to the lower limit value of raster printing.	×
Render Algorithm	ESC * t # j J	Specifies algorithm to express halftone data.	● ⁽⁷⁾
Simple Color	ESC * r # u U	Sets color mode.	○
Current Pattern	ESC * v # t T	Sets pattern type to the raster.	×
Download Pattern	ESC * c # W [pattern data]	Loads user defined pattern.	×
Pattern Control	ESC * c # q Q	Specifies deletion of user defined pattern.	×
Pattern ID	ESC * c # g G	Sets ID of user defined pattern.	×
Pattern Reference	ESC * p # r R	Defines pattern paste position.	×
Logical Operation	ESC * l # o O	Specifies logical operation mode to the raster data.	● ⁽⁸⁾
Pattern Transparency Mode	ESC * v # o O	Turns on/off transparency mode to the pattern.	×
Source Transparency Mode	ESC * v # n N	Turns on/off transparency mode to the source raster.	×

- (1) Parameter value "-1" is treated as "0".
Parameter values "-1 to 3" do not affect the palette information.
- (2) Parameter values "0 to 3" do not affect the palette information.
- (3) Partial page, even if present in received data, is not printed.
- (4) Parameter "4" in the Set Pixel Encoding Mode is not supported.
Range assignable with the Set Number of Bit per Index is 1 to 8.
Range assignable with the Set Number of Bit per Primary is 0 to 8.
- (5) Range of assignable parameter values is 0 to 31 (2**5-1).
- (6) Pen width is not pushed/popped up.
- (7) Effective parameter value of ESC*t#J is "0" only.
- (8) ESC*l#O is effective only for part of logical operation to the monochrome binary raster.

Commands not listed in the table are treated as a command error or thrown away.

D-SCAN Format Command List

Symbols in the following table denote as follows:

- : Denotes the command supported by this plotter.
- × : Denotes the command not supported by this plotter (it is ignored by the plotter).

Note

- ◆ The DSCAN format is for only customers in Japan.

(1/6)

Classification	Command		Function	Support
	Name	16 Hex.		
Basic functions	DUMMY DATA	0000	Shows the end of data in each block.	○
	DIMTAB	01	Performs initialization.	×
	MESSAGE	02	Outputs a message.	×
	PEN	03	Specifies pen number.	○
	PAUSE	04	Makes a pause of plotting.	×
	EOD	05	Shows the end of drawing.	○
	INITIAL LOCATION	06	Sets start coordinate position of a block.	○
	PARABOLA	07	Draws a parabola.	○
	PAPER FEED	08	Shifts subsequent data in X direction.	○
	SPACING	09	Sets symbol spacing.	○
	KANJI	10	Writes kanji.	○
	H SPACE	0E	Sets horizontal space in kanji horizontal writing.	○
	V SPACE	0F	Sets vertical space in kanji vertical writing.	○
	DUMMY VERB	1F	Ignores own data by one byte.	×
	ARC	21 to 3F	Draws an arc or circle.	○
	SYMBOL	40 to 7F	Draws a symbol.	○
	PLOT	80 to FF	Plots a line segment or moves coordinate.	○
	PTN SET	0001	Registers a filling pattern.	○
PATRN	0002	Fills the closed polygon.	○	

Classification	Command		Function	Support
	Name	16 Hex.		
Basic functions	FILECONTROL BLOCK	0003	Sets plotting conditions of file information block.	○
	IEOD	—	Specifies drawing control (whether the drawing is plotted every file or every drawing).	●*
	IFSZX, IFSZY	—	Specifies the drawing size of file.	○
	IDSZX, IDSZY	—	Specifies the drawing size of drawing.	○
	OFFXX, OFFYY	—	Specifies offset amount of drawing.	○
	ISCLX, ISCLY	—	Specifies enlargement or reduction value of drawing.	○
	IROTE	—	Specifies drawing rotation in the unit of 90°	○
	IPEN1 to 8	—	Assigns a pen.	○
	ICUT	—	Cutting	×
	NEST	—	Nesting	×
	ICOPY	—	Specifies the number of copies of drawing.	○
	IASIZ	—	Specifies judgment of drawing size.	○
	IPSIZ	—	Specifies increment of drawing size (X axis).	○
	PEN1W to PEN8W	—	Specifies pen width.	○
	PEN1C to PEN8C	—	Specifies pen color.	○
	MIRR	—	Specifies whether mirror inversion is executed.	○
	RASTR	—	Specifies whether vector and raster are valid or invalid.	○
	REVRS	—	Specifies whether white-black reversal is executed.	○
	MODEC	—	Specifies color mode.	○
	BINNO	—	Specifies output bin number of sorter.	×
STOCK	—	Specifies a stock method of sorter.	×	
PAPER	—	Specifies paper type number.	●*	
USERN	—	Specifies user name (EBCDIC).	×	

* Reserved, not supported

Classification	Command		Function	Support
	Name	16 Hex.		
Basic functions	DRAWING CONTROL BLOCK	0004	Sets plotting conditions of drawing information block.	○
	IEOD	—	Specifies drawing control (whether the drawing is plotted every file or every drawing).	●*
	IFSZX, IFSZY	—	Specifies the drawing size of file.	○
	IDSZX, IDSZY	—	Specifies the drawing size of drawing.	○
	OFFXX, OFFYY	—	Specifies offset amount of drawing.	○
	ISCLX, ISCLY	—	Specifies enlargement or reduction value of drawing.	○
	IROTE	—	Specifies drawing rotation in the unit of 90° .	○
	IPEN1 to 8	—	Assigns a pen.	○
	ICUT	—	Cutting	×
	NEST	—	Nesting	×
	ICOPY	—	Specifies the number of copies of drawing.	○
	IASIZ	—	Specifies judgment of drawing size.	○
	IPSIZ	—	Specifies increment of drawing size (X axis).	○
	PEN1W to PEN8W	—	Specifies pen width.	○
	PEN1C to PEN8C	—	Specifies pen color.	○
	MIRR	—	Specifies whether mirror inversion is executed.	○
	RASTR	—	Specifies whether vector and raster are valid or invalid.	○
	REVRS	—	Specifies whether white-black reversal is executed.	○
	MODEC	—	Specifies color mode.	○
	BINNO	—	Specifies output bin number of sorter.	×
	STOCK	—	Specifies a stock method of sorter.	×
PAPER	—	Specifies paper type number.	●*	
USERN	—	Specifies user name (EBCDIC).	×	

* Reserved, not supported

Classification	Command		Function	Support
	Name	16 Hex.		
Advanced functions	LINE WIDTH	1101	Sets line width of a pen.	○
	LINE TYPE	1102	Sets line type of a pen.	○
	LINE COLOR	1103	Sets line color of a pen.	○
	LINE PATTERN	1104	Registers a line type pattern.	○
	COLOR	1105	Sets color components.*	○
	CHARACTER HEIGHT	1110	Sets character height (in mm).	○
	CHARACTER WIDTH	1111	Sets character width (ratio to character height).	○
	CHARACTER SPACING	1112	Sets character spacing (ratio to character height).	○
	CHARACTER SLANT	1113	Sets character direction.	○
	TEXT PATH	1114	Sets text direction (up, down, left, right).	○
	TEXT ALIGNMENT	1115	Sets text alignment reference (in horizontal and vertical directions).	○
	CHARACTER SET	1116	Selects character set.	○
	KANJI HEIGHT	1120	Sets kanji height (in mm).	○
	KANJI WIDTH	1121	Sets kanji width (ratio to kanji height).	○
	KANJI SPACING	1122	Sets kanji spacing (ratio to kanji height).	○
	KANJI SLANT	1123	Sets kanji direction.	○
	KANJI PATH	1124	Sets kanji string direction (up, down, left, right).	○
	KANJI ALIGNMENT	1125	Sets kanji string alignment reference (in horizontal and vertical directions).	○
	CIRCLE	1140	Draws a full circle.	○
	ARC	1141	Draws an arc.	○
	TEXT	1142	Draws a text.	○
	KANJI	1143	Draws a kanji.	○
	FILL AREA CIRCLE	1150	Fills a full circle.	○
	FILL AREA FAN	1151	Fills a fan-shape.	○
FILL AREA BOW	1152	Fills a bow-shape.	○	

* Using maximum values of four parameters (0 to 255) that specify the rate of yellow, magenta, cyan, and black, 16-step gradation is determined to express a black tone.

(5/6)

Classification	Command		Function	Support
	Name	16 Hex.		
Advanced functions	WINDOW	1160	Sets a window.	○
	VIEWPORT	1161	Sets a view port.	○
	FILL AREA STYLE	1162	Sets internal style of polygon.	○
	FILL AREA BASE POINT	1163	Sets base point of pattern and hatch.	○
	WRITE MODE	1164	Selects whether last writing is preferential or overwriting is executed.	○
	MARKER MODE	1170	Sets marker attribute (height, ON/OFF of coordinate conversion).	○
	LINE MODE	1171	Sets line type attribute (continuous mode/guarantee mode).	○
	RASTER ALIGNMENT	1180	Sets raster alignment reference and alignment direction.	○
	RASTER SCALE	1181	Sets raster scale.	○
	RASTER BYTE MIRROR	1182	Sets alignment direction of top bit (LSB or MSB).	○
	PIXEL ALIGNMENT	1183	Sets pixel alignment reference and alignment direction.	○
	RASTER GROUP START	1184	Specifies the start of raster group.	○
	RASTER GROUP END	1185	Specifies the end of raster group.	○
	RASTER SCALE 2	1186	Sets raster input resolution.	○
	DIRECT RASTER	1190	Sets information on direct raster.	○
	PACKING RASTER	1191	Sets information on packing raster.	○
	PIXEL	1192	Pixel	○
	AREA CLEAR	1193	Sets the white filling area.	○
	RASTER CLIP	1194	Sets raster clip area.	○
	DIRECT RASTER 2	1195	Sets information on direct raster (2).	○
PACKING RASTER 2	1196	Sets information on packing raster (2).	○	
PIXEL 2	1197	Pixel	○	

Classification	Command		Function	Support
	Name	16 Hex.		
Advanced functions	RASTER (MH)	1198	Sets information on compressed raster (MH).	○
	RASTER (MR)	1199	Sets information on compressed raster (MR).	○
	RASTER (MMR)	119A	Sets information on compressed raster (MMR).	○
	DIRECT RASTER 3	119B	Sets information on direct raster (3) (Base point (metric system))	○
	PACKING RASTER 3	119C	Sets information on packing raster (3) (Base point (metric system))	○
	RASTER (MH-2)	119D	Sets information on compressed raster (MH-2) (Base point (metric system))	○
	RASTER (MR-2)	119E	Sets information on compressed raster (MR-2) (Base point (metric system))	○
	RASTER (MMR-2)	119F	Sets information on compressed raster (MMR-2) (Base point (metric system))	○
	KANJI DEFINE	11A0	Registers kanji.	×
	KANJI DELETE	11A1	Deletes kanji.	×
	SET PATTERN	1201	Registers a pattern.*	○
	SET HATCH	1202	Registers a hatch.	○
	POLYLINE	1210	Polyline	○
	POLYMARKER	1211	Polymarker	○
	POLYGON SET	1212	Sets polygon.	○
	CELL ARRAY	1213	Cell array	○
	DIRECT RASTER DATA	1220	Sets direct raster data.	○
	PACKING RASTER DATA	1221	Sets packing raster data.	○
	PIXEL DATA	1222	Pixel data	○
	CONTINUATION DATA	12FF	Continuation data of the preceding block	○

* Yellow, magenta, and cyan pattern array is registered as a black pattern array, and the registered dots are all expressed in black.

TIFF Tag

Symbols in the following table denote as follows:

- : Denotes the command supported by this plotter.
- : Denotes that only part of the command function is supported by this plotter.
- × : Denotes the tag not supported by this plotter.



Tips

- ◆ Tags supported by this plotter are those of the TIFF Revision 4.0.
- ◆ If data larger than spool buffer size is received, an error message is displayed on the panel, and the data is discarded.
- ◆ If a tag not supported by this plotter is received, that tag is ignored.

Command		Function	Support
Name	16 Hex.		
NewSubfileType	00FE	Specifies a type of image data.	●
SubfileType	00FF	Specifies a type of image data.	●
ImageWidth	0100	Specifies the pixels per row of image.	○
ImageLength	0101	Specifies the number of rows of image.	○
BitsPerSample	0102	Specifies the bits per sample.	○
Compression	0103	Specifies a compression format.	○
PhotometricInterpretation	0106	Specifies an interpretation method of value in bit map.	○
FillOrder	010A	Specifies a pixel data storing format to byte.	○
StripOffsets	0111	Specifies offset value to each strip.	○
Orientation	0112	Specifies image origin, pixel advance direction and line advance direction.	○
SamplesPerPixel	0115	Specifies the number of samples per pixel.	○
RowsPerStrip	0116	Specifies the number of rows of each strip before compression.	○
StripByteCounts	0117	Specifies the bytes of each strip after compression.	○
MinSampleValue	0118	Specifies the minimum sample value.	○
MaxSampleValue	0119	Specifies the maximum sample value.	○
XResolution	011A	Specifies the pixels per resolution unit in row direction.	○
YResolution	011B	Specifies the pixels per resolution unit in column direction.	○
PlanerConfiguration	011C	Specifies each pixel element storing format.	○
XPosition	011E	Specifies offset value in X direction of image.	○
YPosition	011F	Specifies offset value in Y direction of image.	○
T4Options	0124	Specifies optional information on T4 compression.	●
ResolutionUnit	0128	Specifies physical unit of resolution unit in XResolution and YResolution tags.	○
Color Map	0140	Specifies palette color table (RGB).	○

CALS Format Records

Symbols in the following table denote as follows:

- : Denotes the record supported by this plotter.
- × : Denotes the record not supported by this plotter.



- ◆ Only the TYPE I format is supported by this plotter. If the data of TYPE II is received, the data is discarded.
- ◆ If a record not supported by this plotter is received, that record is ignored.

Record	Function	Support
rtype	Specifies the data type.	○
rorient	Specifies the orientation of drawing.	○
rpelcnt	Specifies the dots per line and the number of lines.	○
rdensty	Specifies the dots per inch.	○

ftp Tag

The LP-1020 supports the ftp that transfers usual plot data and the anonymous ftp. The anonymous ftp enables you to log in by entering "anonymous" in the user name. The ftp for data transfer enables ten users to be logged in simultaneously, while the anonymous ftp enables one user to be logged in simultaneously.

Command name	Function	Default	Remarks
ascii	Sets the file transfer type to ASCII.	_____	
binary	Sets the file transfer type to binary. This binary command must be set when file is transferred.	Image	
bye	Ends the execution of ftp command.	_____	
cd	Changes a working directory.	_____	Supported by anonymous ftp
cdup	Moves a working directory to the root directory.	_____	
close	Releases the connection to the plotter, and displays the ftp prompt.	_____	
disconnect		_____	
delete (file name)	Deletes an unprocessed file transferred to the plotter.	_____	Not supported by anonymous ftp
mdelete (file n)	Deletes multiple unprocessed files transferred to the plotter.	_____	
dir	Outputs the file information transferred to the plotter and stored in the spool.	_____	
mdir		_____	
ls		_____	
mls		_____	
get		Copies one file in the plotter to the local host	_____
mget	Copies multiple files in the plotter to the local host.	_____	
mode (mode name)	Sets the file transfer mode.	stream	
open (remote unit)	Makes a connection to the plotter. After the open command is executed, the user name and password must be entered.	_____	
put (file name)	Copies one file in the computer to the plotter.	_____	Not supported by anonymous ftp
mput (file name)	Copies one or multiple files in the computer to the plotter.	_____	
pwd	Displays path name of current directory. The path of directory is always "/" (root).	_____	
quit	Ends the execution of ftp command.	_____	
recv	Copies one file in the plotter to the local host.	_____	Supported by anonymous ftp
remotehelp (internal command)	Displays help information on internal commands supported by the ftp server of the plotter (if internal command is omitted, a list of internal commands is displayed).	_____	
send (file name)	Copies one file in the computer to the plotter.	_____	Not supported by anonymous ftp
struct (structure name)	Sets the file transfer structure.	file	
sunique	Stores a file in the spool of the plotter using different name, if the file of same name as that of the transferred file already exists.	_____	Not supported by anonymous ftp
type (type name)	Sets the file transfer type.	Image	
user (user name)	Logs in the ftp server of the plotter. After the user command is executed, the user name and password must be entered.	_____	



Tip

- ◆ Three protocols of ftp (for data transfer), lpr (lpq, lprm), and xpt enable the maximum ten users to be connected.

lpd Support Commands

The lpr, lpq, and lprm commands enable ten users to be connected simultaneously.

■ lpd support commands

Command name	Function
lpr	Copies a file in the computer to the plotter.
lpq	Outputs the spool data in the plotter to the computer.
lprm	Deletes an unprocessed file transferred to the plotter.



Tip

- ◆ Three protocols of ftp (for data transfer), lpr (lpq, lprm), and xpt enable the maximum ten users to be connected.

xpt(socket I/F)

The LP-1020 enables the data transfer from a maximum of ten users.



Tip

- ◆ Three protocols of ftp (for data transfer), lpr (lpq, lprm), and xpt enable the maximum ten users to be connected.