



# DI-80

*Indicator*

# Service Manual





**1. GENERAL SPECIFICATION**

Model	:	DI 80
Dimension	:	255 (L) X 240 (W) X 146 (H)
Number Of Loadcells	:	max 2 x External Platform or max 8 x Loadcells in parallel configuration (350 ohm type) (6-wires remote sensing available)
Input Sensitivity	:	0.4 to 4 mV/V (12 V excitation)
Type Of Display	:	LCD with CCFL back-light (Colour weight checker bar on LCD)
Display Resolution	:	1 / 2,500 ; 1 / 5,000 ; 1 / 10,000
Counting Resolution	:	1 / 500,000
Keyboard	:	Mechanical key switch
Memory	:	Standard 128K bytes ( approx. 1000 items ) ; Expandable to max 256K bytes ( approx. 2000 items )
Set Point Output	:	max. 4 set points (Open Collector type)
Interface	:	i) RS232C, Set point (Standard) ii) Thermal Printer (Optional, OP1) iii) Line Printer (Optional, OP2) iv) RS232C with RS485 (Optional, OP3) vi) Analogue output (Optional, OP4)
Power Source	:	i) 6 x D size battery (Rechargeable type accepted; rechargeable circuit in-built) ii) AC/ DC adapter DC 9 ~ 12 V / 1.5A
Operating Temperature	:	-10°C ~ 40°C (14°F ~ 104°F)
Operating Humidity	:	15% ~ 85%
External Device	:	i) Barcode scanner (RS232C) ii) Label Printer COSTAR SE 250 iii) Thermal Printer ELTRON LP 2622

2. OVERALL DIMENSION

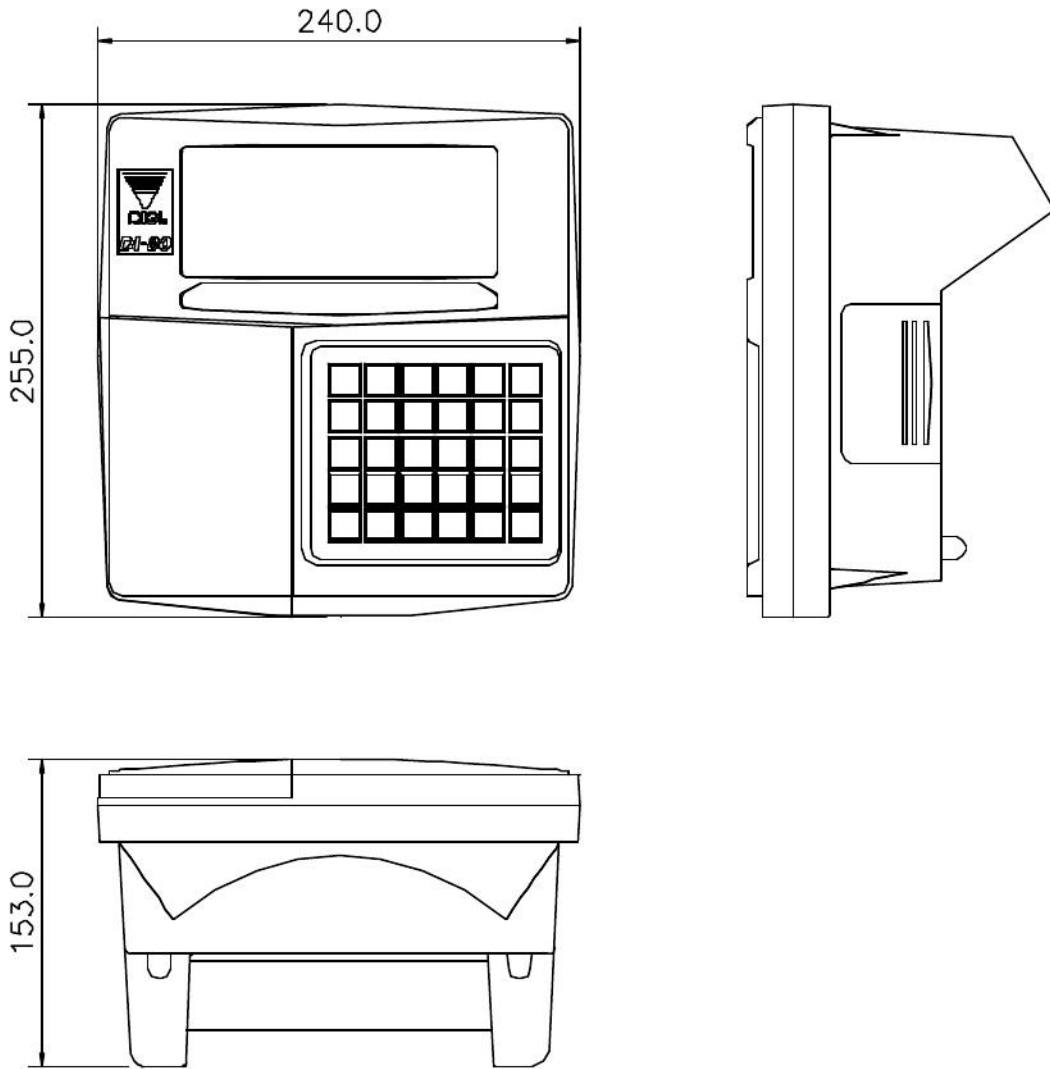



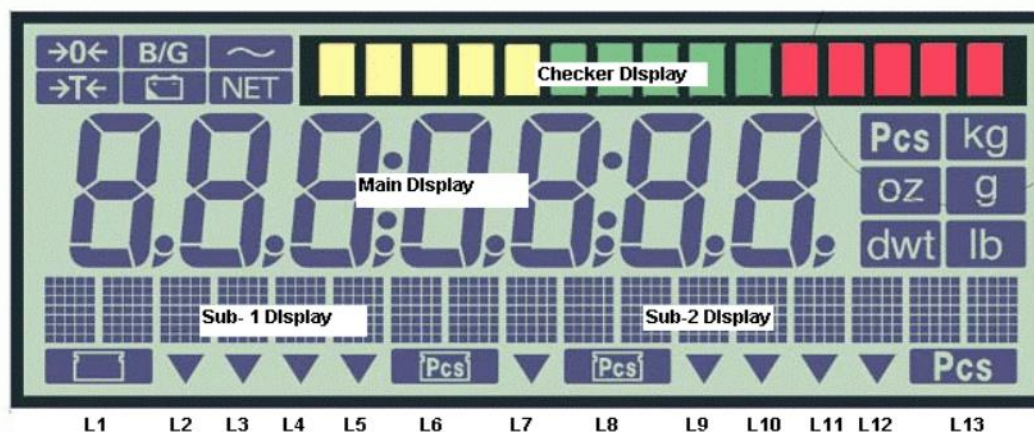





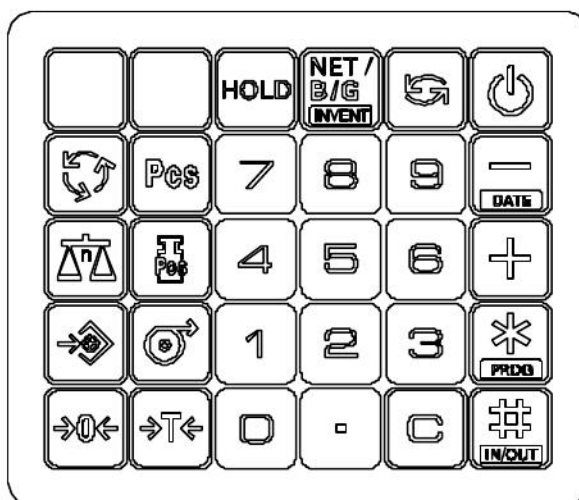

## 3. DISPLAY LAYOUT











Segment Name	Label	Functions
→0←	-	ON when Net weight is zero
B/G	-	ON when displaying gross weight
→T←	-	ON when weight is tared
NET	-	ON when main display is showing Net Weight
~	-	ON when weight is stable
	-	ON when battery voltage run low
Main Display	-	To display weight , quantity, etc depending on the mode of operation
Pcs	-	ON when main display is showing Quantity
kg	-	ON when main display is showing Weight in kg
oz	-	ON when main display is showing Weight in oz
g	-	ON when main display is showing Weight in g
lb	-	ON when main display is showing Weight in dwt
dwt	-	ON when main display is showing Weight in dwt
sub-1 display	-	Display Total weight, Unit weight, or PLU name depending on mode operation
sub-2 display	-	Display Unit weight , Quantity, setpoint, or PLU name depending on mode operation
	L1	ON when sub-1 display is showing total weight
INSUFF indicator	L2	ON when net weight is below a specific percentage of capacity weight
RECOM indicator	L3	ON when unit weight re-computing is possible
IN indicator	L4	ON when inventory IN
OUT indicator	L5	ON when inventory OUT
	L6	ON when sub-1 display is showing unit weight
HOLD indicator	L7	ON when holding function is enable
	L8	ON when sub-2 display is showing unit weight
MEMORY indicator	L9	ON when quantity accumulated overflow or memory overflow
PROG indicator	L10	ON when user is in programming mode
SCALE 1 indicator	L11	ON when scale 1 is selected
SCALE 2 indicator	L12	ON when scale 2 is selected
	L13	ON when sub-2 display is showing quantity

## 4. KEYSHEET LAYOUT



Key Name	Weighing / Counting mode	Self Test	Calibration	SPEC141 / SPEC142	PROG Mode
	ON/OFF				
	Switch between weighing and counting mode		Exit from calibration mode	Exit from service mode	Exit from program mode
	Rezero DI-80 and combine with other key to enter to various mode		Perform rezeroing		Rezero
	Clear key entry or RAM data	Clear message	Clear key entry	Clear key entry	Clear key entry
	Perform one-touch tare or digital tare		Increase sensitivity		Perform one-touch tare or digital tare
	Sampling operation		Reduce sensitivity		Sampling operation
	Switching scale				Switching scale
	Enter unit weight				Enter unit weight
	Accumulation	Select type of self test	Shift zero point up	Increment SPEC number	Enter PLU setpoint

Key Name	Weighing / Counting mode	Self Test	Calibration	SPEC141 / SPEC142	PROG Mode
	Reduction	Select type of self test	Shift zero point down	Decrement SPEC number	Enter Part No or date and time entry
	Printing Operation	Perform test	Span weight entry	Save SPEC setting	Save data
	Calling out PLU				Enter PLU Name or call out PLU or check PLU code in memory
	Switch between Net and Gross display				
	Enter Decimal point or switch to Teraoka code entry		Enter Decimal point		Enter Decimal point or switch to Teraoka code entry
	Enter general setpoint				
	Line feed				
	Enable/ disable hold function				
	Provide unit switching between kg / lb or oz / g / dwt				Provide unit switching between kg / lb or oz / g / dwt

## 5. INITIAL SET UP

### 5.1 LOCATION OF CONNECTOR AND SWITCH

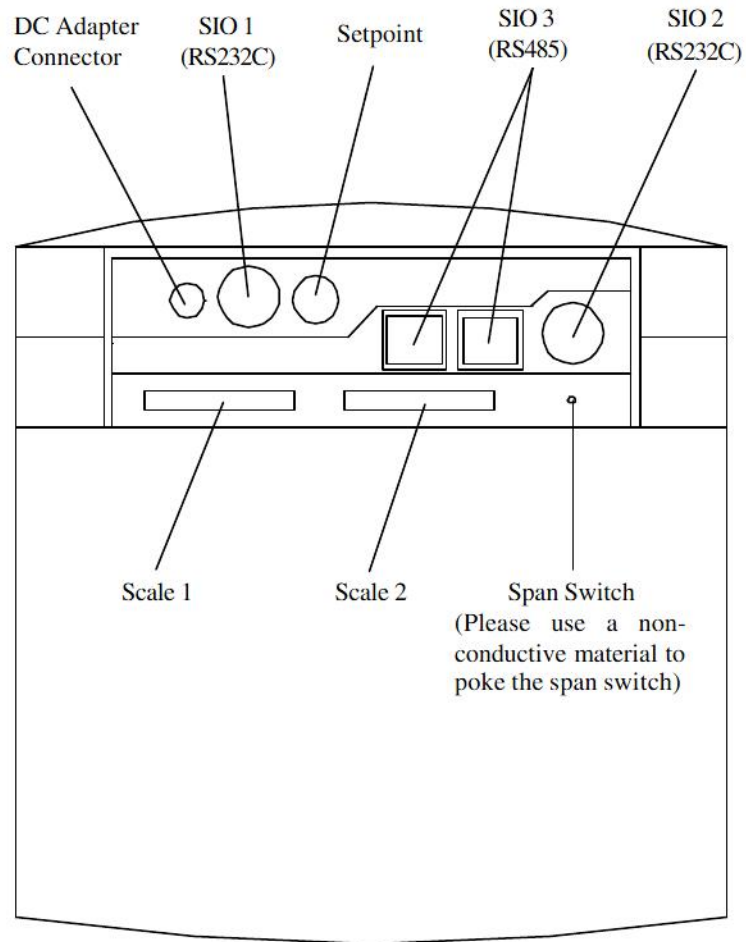

Back of DI 80

### 5.2 MEMORY CLEAR

OPERATION	DISPLAY			REMARKS
	Main (W)	Sub-1(UW)	Sub-2 (Q)	
[REZERO] + [MODE] key	ProG	PLU	Count 10	Go to Program mode
[REZERO] + [.] [.] [0]	ALL		CLEAR	To memory clear mode.
[CLEAR]	ProG	PLU	Count 0	Delete all memory.

## 6. SOFTWARE SETTING

## 6.1 CUSTOMER SPEC SETTING

OPERATION	DISPLAY			REMARKS
	Main(W)	Sub-1(UW)	Sub-2(Q)	
	0.000	0	0	Weighing mode.
[REZERO]+ [1][4][1]	SPC00		0000	Customer SPEC mode.
[+]	SPC01		0000	Increases to the next SPEC number and also stores temporarily the SPEC data in the RAM location.
[1][0][1][1]	SPC01	1 0 1 1	0000	The Sub-1 section will display the keyed in data.
[+]	SPC02		0000	Increases to the next SPEC number.
[-]	SPC01		1 0 1 1	Decreases to the previous SPEC number.
[1][1][1][1]	SPC01	1 1 1 1	1 0 1 1	Enter new data.
[C]	SPC01		1 0 1 1	Clear the keyed in data on Sub-1.
[*]	PROG		C 0 0	Store all SPEC values to the EEPROM and exits from the SPEC setting mode.
[MODE]	0.0000	0	0	Press [MODE] key to escape from Maintenance mode to weighing mode.

## 6.2 WEIGHT AND MEASURE SPEC SETTING

OPERATION	DISPLAY			REMARKS
	Main(W)	Sub-1(UW)	Sub-2(Q)	
	S-On			Depress the SPAN SWITCH. The S-On message comes on.
[REZERO] + [1][4][2]	SPC20		0000	Weigh & Measure SPEC mode.
[+]	SPC21		0000	Increases to the next SPEC number and also stores temporarily the SPEC data in the RAM location.
[1][0][1][1]	SPC21	1 0 1 1	0000	The Sub-1 section will display the new keyed in data.
[+]	SPC22		0000	Increases to the next SPEC number.
[-]	SPC21		1 0 1 1	Decreases to the previous SPEC number.
[1][1][1][1]	SPC21	1 1 1 1	1 0 1 1	Enter new data.
[C]	SPC21		1 0 1 1	Clear the keyed in data on Sub-1.
[*]	PROG	PLU	Count 0	Store all SPEC values to the EEPROM and exits from the SPEC setting mode.
[MODE]	S-On			Press [MODE] key to escape from Spec Setting mode. The display shows S-On indicating that the span switch is ON.
Press the SPAN SWITCH.	0.0000	0	0	Depressing the Span Switch switches to the weighing mode.

## 6.3 SPECIFICATION LIST (REVISION 10)

## 6.3.1 DI-80 SOFTWARE HISTORY

Revision No.	Modification Details	Software Version
0	First release.	V0.21
1	Change calibration procedures	V0.42
2	a. Add SPEC14 BIT2 for "Tare Printing for Build-in Printer" b. Add SPEC15 BIT 2 for "Line Feed after Total Print" c. Add SPEC02 BIT3-1 for "Buzzer on Delay Function" d. Remove SPEC39 BIT3 for "Basic A/D Setup" e. Remove SPEC39 BIT2 for "Type of Calibration"	V1.03
3	Add SPEC19 BIT3 for "Print DIGI MATEX Footer on Label Printer SE250"	V1.06
4	Add SPEC00 BIT1 for "Send Net and Tare Weight only in RS-232C Mode"	V1.08
5	a. Add SPEC11 BIT0 for "Send LF for LX-Serial Line Printer" b. Add SPEC12 BIT1 for "Item Count for Minus Key Operation" c. Add new option on "Serial Line Printer" for SPEC08 BIT2-0	V1.12
6	a. Change SPEC36 BIT3&2 to "Weight Data Update" b. Change SPEC36 BIT1&0 to "WS Condition" c. Change SPEC37 BIT3-1 to "Digital Filter Used" d. Change SPEC37 BIT0 to "Digital Tare when Loaded" e. Change SPEC38 BIT3-1 to "Digital Filter Level"	V1.14
7	Add SPEC58 BIT2 for Negative Weight Operation"	V1.16
8	Add SPEC24 BIT0 for "Tare Indication Method"	V1.17
9	a. Add SPEC59 BIT3 for "LCD Type" b. Add SPEC59 BIT2 for "Build-in Printer Type"	V1.18
10	a. Add SPEC58 BIT1 for "Printing within SP1 and SP2" b. Add SPEC58 BIT0 for "Out Set Point when Weight is stable"	V1.21

## 6.3.2 CUSTOMER SPECIFICATION [REZERO] + [1][4][1]

SPEC NO.	BIT 3	BIT 2	BIT 1	BIT 0
0	<b>U1 Version</b> 0 : No 1 : Yes	<b>Recall Last Zero on Power Up</b> 0 : Inhibit 1 : Allow	<b>Send Net and Tare Weight only in RS-232C Mode</b> 0 : No 1 : Yes	<b>Set Point Display</b> 0 : No 1 : Yes
1	<b>Auto Power Off Function</b> 0000 : Disable 0100 : 4 min 1000 : 8 min 1100 : 12 min 0001 : 1 min 0101 : 5 min 1001 : 9 min 1101 : 13 min 0010 : 2 min 0110 : 6 min 1010 : 10 min 1110 : 14 min 0011 : 3 min 0111 : 7 min 1011 : 11 min 1111 : 15 min			
2	<b>Buzzer on Delay Function (&lt; Set Point 1)</b> <i>(effective when SPEC17 BIT2 = 1)</i> 000 : No delay 011 : 3 sec 110 : 6 sec 001 : 1 sec 100 : 4 sec 111 : 7 sec 010 : 2 sec 101 : 5 sec			<b>Inventory Display by Gross Key</b> 0 : Gross display 1 : No. of inventory
3	<b>ID Code</b> 00 : Not used 01 : 16 digits Teraoka code 11 : 16 digits numeric number only 10 : Not used	<b>Entry Part No.</b> 00 : 12 numeric number only 01 : Not used 11 : 16 digits Teraoka code 10 : Not used		
4	<b>Set New Item Code during Normal Mode</b> 0 : Yes 1 : No	<b>Extent of Insufficient Samples</b> 00 : 0.1 % 01 : 0.2 % 10 : 0 %		<b>Negative Counting</b> 0 : No 1 : Yes
5	<b>Sampling Time for Unit Weight Calculation</b> 0 : 10 times 1 : 5 times	<b>Unit Weight Auto Re-computing</b> 0 : No 1 : Yes	<b>Date Order</b> 00 : Year, Month, Date 01 : Date, Month, Year 11 : Month, Date, Year 10 : Not used	
6	<b>Display Accuracy of Unit Weight</b> 0 : No 1 : Yes	<b>Clear All Input Key in One Touch</b> 0 : Yes 1 : No	<b>RS-232C Continue Sending Rate to PC</b> 0 : High 1 : Low	<b>Auto Shift to Next Position after Two Keys of Teraoka Code Entry</b> 0 : No 1 : Yes
7	<b>Set Point Buzzer</b> 1 : Yes 0 : No	<b>Set Point</b> 0 : Latch 1 : No Latch	<b>Set Point Type</b> 00 : %Quantity 10 : Quantity 01 : %Weight 11 : Weight	
8	<b>SIO1 Connection</b> 0 : No 1 : Yes	<b>Type of Devices</b> <sup>*2</sup> 000 : Barcode scanner <sup>*3</sup> 001 : PC 010 : LP2622 / LP2722 printer <sup>*4</sup> 011 : SE250 printer 100 : Serial line printer (net mode, KG operation) 101 ~ 111 : Not used		
9	<b>SIO1 Data Length</b> 0 : 7 bits 1 : 8 bits	<b>SIO1 Baud Rate</b> 000 : 1200 011 : 9600 110 ~ 111 : Not used 001 : 2400 100 : 19200 010 : 4800 101 : 38400		
10	<b>SIO1 Send with Header</b> <sup>*1</sup> 0 : Yes 1 : No	<b>SIO1 Header Type</b> <sup>*1</sup> 0 : Code 1 : Text	<b>SIO1 Parity</b> 00 : No 10 : Not used 01 : Odd 11 : Even	
11	<b>SIO1 Mode of Operation</b> <sup>*1</sup> 00 : Remote trigger 01 : Continuous mode 10 : Manual mode 11 : Continuous and manual mode		<b>SIO1 Stop Bit</b> 0 : 1 bit 1 : 2 bits	<b>Send "LF" for LX Serial Line Printer</b> 0 : No 1 : Yes
12	<b>TTL Output</b> 00 : Holding output (weight stable + Hold) 01 : Set point output 10 : Checker output 11 : Disable		<b>Item Code for Minus Key Operation</b> 0 : Plus 1 : Minus	<b>Unit Switching</b> 0 : No 1 : Yes

SPEC NO.	BIT 3	BIT 2	BIT 1	BIT 0
13	<b>Build-in Printer</b> 0 : No 1 : Yes	<b>Auto Print</b> 0 : No 1 : Yes	<b>Date and Time Print</b> 0 : No 1 : Yes	<b>Allow PLU Calling when Memory Flag Set</b> 0 : No 1 : Yes
14	<b>Character Key Entry</b> 0 : Teraoka code 1 : ASCII code	<b>Tare Printing for Build-in Printer</b> 0 : No 1 : Yes	<b>PLU Name Print</b> 0 : No 1 : Yes	<b>Blank Line between Each Item Printed</b> 0 : No 1 : Yes
15	<b>Item Type for Auto Print</b> 0 : Single 1 : Accumulation	<b>Line Feed after Total Print</b> 0 : No 1 : Yes	<b>Holding Function</b> 0 : No 1 : Yes	<b>Type of Holding</b> 0 : Normal 1 : Peak
16	<b>LCD Back-light Auto Off Function</b> 0000 : Always OFF 0100 : 4 min 1000 : 8 min 1100 : 12 min 0001 : 1 min 0101 : 5 min 1001 : 9 min 1101 : 13 min 0010 : 2 min 0110 : 6 min 1010 : 10 min 1110 : 14 min 0011 : 3 min 0111 : 7 min 1011 : 11 min 1111 : Always ON			
17	<b>LCD Light Off when No AC</b> 0 : No 1 : Yes	<b>Buzzer On</b> 0 : When weight is within SP1 and SP2 1 : When weight is outside SP1 and SP2	<b>Not Used</b>	
18	<b>Set Point TTL Output</b> 0 : Active low 1 : Active high	<b>Number of Set Points</b> 000 : 2 set points 010 : 4 set points 001 : 3 set points 011 ~ 111 : Not used		
19	<b>Display "PLU not found" Message</b> 0 : Yes 1 : No	<b>Print DIGI Matex Footer on Label Printer SE250</b> 0 : Yes 1 : No	<b>Not Used</b>	<b>Print when [+] or [-] Key in Add Mode</b> 0 : Yes 1 : No
50	<b>SIO2 (RS-232C) Connection</b> 0 : No 1 : Yes	<b>SIO2 Type of Device</b> <sup>*2</sup> 0 0 0 : Barcode scanner <sup>*3</sup> 0 0 1 : PC 0 1 0 : LP2622 / LP2722 printer <sup>*4</sup> 0 1 1 : SE250 printer 100 ~ 111 : Not used		
51	<b>SIO2 Data Length</b> 0 : 7 bits 1 : 8 bits	<b>SIO2 Baud Rate</b> 000 : 1200      011 : 9600      101 ~ 111 : Not used 001 : 2400      100 : 19200 010 : 4800 101 : 38400		
52	<b>SIO2 Send with Header</b> <sup>*1</sup> 0 : Yes 1 : No	<b>SIO2 Header Type</b> <sup>*1</sup> 0 : Code 1 : Text	<b>SIO2 Parity</b> 00 : No      10 : Not used 01 : Odd 11 : Even	
53	<b>SIO2 Mode of Operation</b> <sup>*1</sup> 00 : Remote trigger 01 : Continuous mode 10 : Manual mode 11 : Continuous and manual mode		<b>SIO2 Stop Bit</b> 0 : 1 bit 1 : 2 bits	<b>Not Used</b>
54	<b>SIO3 (RS-485) Connection</b> 0 : No 1 : Yes	<b>SIO3 Type of Device</b> <sup>*2</sup> 000 : Not used 001 : PC 010 ~ 111 : Not used		
55	<b>SIO3 Data Length</b> 0 : 7 bits 1 : 8 bits	<b>SIO3 Baud Rate</b> 000 : 1200      011 : 9600      110 ~ 111 : Not used 001 : 2400      100 : 19200 010 : 4800 101 : 38400		
56	<b>SIO 3 Send with Header</b> <sup>*1</sup> 0 : Yes 1 : No	<b>SIO3 Header Type</b> <sup>*1</sup> 0 : Code 1 : Text	<b>SIO3 Parity</b> 00 : No      10 : Not used 01 : Odd 11 : Even	
57	<b>SIO3 Mode of Operation</b> <sup>*1</sup> 00 : Remote trigger 01 : Continuous mode 10 : Manual mode 11 : Continuous and manual mode		<b>SIO3 Stop Bit</b> 0 : 1 bit 1 : 2 bits	<b>Not Used</b>

SPEC NO.	BIT 3	BIT 2	BIT 1	BIT 0
58	<b>Analogue Output</b> 1 : Yes 0 : No	<b>Negative Weight Operation</b> *5 1 : Yes 0 : No	<b>Printing Allow when Weight is within SP1 and SP2</b> 0 : No 1 : Yes	<b>Output Set Point when Weight stable</b> 0 : Yes 1 : No
59	<b>LCD Type</b> 1 : Euro (new) 0 : Japan	<b>Build-in Printer Type</b> 1 : Line thermal head printer (ALPS) 0 : Thermal head printer (Seiko)	<b>Not Used</b>	

- NOTE :**
- \*1 Ignored setting if device is barcode scanner.
  - \*2 Same device cannot be reselected in SPEC 08, SPEC 50, SPEC 54.
  - \*3 Only period (.) for decimal point is allowed for barcode scanning.
  - \*4 Free Formats are required to pre-load into LP2622 and LP2722
  - \*5 Not applicable for Auto Printing function.

**REMARK: All "Not Used" BIT must be set to 0.**

### 6.3.3 WEIGHT AND MEASURE SPECIFICATION [REZERO] + [1][4][2] (Span Switch must be turned ON when accessing this mode)

SPEC NO.	BIT 3	BIT 2	BIT 1	BIT 0
20	<b>Dual Range Operation</b> 00 : No 01 : Dual range in gross 10 : Dual range in net 11 : No used		<b>Not Used</b>	
21 & 22	<b>Not Used</b>			
23	<b>Not used</b>		<b>Zero Setting Range</b> 00 : + Unlimited / 10 : ±10% FS - 10% FS 01 : ± 2% FS    11 : Not available	
24	<b>Masked Display at Minus Weight</b> 0 : Gross 1 : Net	<b>Display at Minus Weight</b> 0 : Minus display 1 : Masked	<b>Zero Lamp Lighting Method</b> 0 : Gross 1 : Net	<b>Tare Indication Method</b> 0 : Tare lamp 1 : Net lamp
25	<b>Scale Starting Method</b> 0 : Automatic 1 : Manual	<b>IR Mode Protected by Span Switch</b> 0 : No 1 : Yes	<b>Second Scale</b> 0 : No 1 : Yes	<b>Gross Mode Available</b> 0 : Yes 1 : No
26	<b>Zero Tracking when Tare</b> 0 : Yes 1 : No	<b>Weight Reset when Tare</b> 0 : Yes 1 : No	<b>Initial Start Range</b> 00 : + Unlimited / 10 : ± 10% FS - 10% FS 01 : ± 2% FS    11 : Not available	
27	<b>Comma Display</b> 0 : No 1 : Yes	<b>Digital Tare Setting</b> 0 : No 1 : Yes	<b>Tare Range</b> 00 : 100% FS    10 : < 5% FS 01 : < 50% FS    11 : Not available	
28	<b>Auto Tare Clear when Rezero</b> 0 : No 1 : Yes	<b>Actuation Weight Condition ***</b> 00 : >= net 5d and gross 21d 01 : >= net 1d 10 : >= net 5d 11 : >= net 21d		<b>Automatic Unit Weight Clear</b> 0 : No 1 : Yes
29	<b>Digital Tare Rounding (Store)</b> 0 : Tare exactly 1 : Round to nearest increment	<b>Not Used</b>	<b>Tare Addition</b> 0 : Yes 1 : No	<b>Tare Subtraction</b> 0 : Yes 1 : No
30	<b>Load Cell sensitivities Selection (mV/V) (Scale 1)</b> 0000 : 4.00 0100 : 3.04 1000 : 2.08 1100 : 1.12 0001 : 3.76                    0101 : 2.80 1001 : 1.84 1101 : 0.88 0010 : 3.52                    0110 : 2.56 1010 : 1.60 1110 : 0.64 0011 : 3.28                    0111 : 2.32 1011 : 1.36 1111 : 0.40			
31	<b>Load Cell Sensitivities Selection (mV/V) (Scale 2)</b> 0000 : 4.00 0100 : 3.04 1000 : 2.08 1100 : 1.12 0001 : 3.76                    0101 : 2.80 1001 : 1.84 1101 : 0.88 0010 : 3.52                    0110 : 2.56 1010 : 1.60 1110 : 0.64 0011 : 3.28                    0111 : 2.32 1011 : 1.36 1111 : 0.40			
32	<b>Calibration / Default SPEC/ SPEC 142 Mode Protected by Span Switch</b> 1 : No 0 : Yes	<b>Not Used</b>	<b>Auto Exit from Add Mode</b> 0 : No 1 : Yes	<b>Not Used</b>
33	<b>Over Weight Mask</b> 0 : + 1d 1 : + 9d	<b>Not Used</b>		
34	<b>Not Used</b>	<b>Load Cell Type (Scale 1)</b> 0 : For standard / normal load cell 1 : For abnormal load cell with too large offset	<b>A/D Board (Scale 1)</b> 00 : Normal 01 : Prevent from small vibration / fast change in display 10 : Prevent from medium vibration 11 : Prevent from large slow change in display	

SPEC NO.	BIT 3	BIT 2	BIT 1	BIT 0
35	Not Used	<b>Load Cell Type (Scale 2)</b> 0 : For standard / normal load cell 1 : For abnormal load cell with too large offset	<b>A/D Board (Scale 2)</b> 00 : Normal 01 : Prevent from small vibration / fast change in display 10 : Prevent from medium vibration 11 : Prevent from large slow change in display	
36	<b>Weight Data Update</b> 00 : 1 in 1 time 10 : 1 in 4 times 01 : 1 in 2 times 11 : 1 in 8 times		<b>Weight Stable Condition</b> 00 : Loose 10 : Tight 01 : Normal 11 : Stringent	
37	<b>Digital Filter Used</b> 000 : 1 times 011 : 8 times 110 ~ 111 : Not used 001 : 2 times 100 : 16 times 010 : 4 times 101 : 32 times			<b>Digital Tare when Loaded</b> 0 : Allow 1 : Inhibit
38	<b>Digital Filter Level</b> 000 : Level 0 010 : Level 2 100 ~ 111 : Not used 001 : Level 1 011 : Level 3			<b>Stability Check when Changing Scale **2</b> 0 : Yes 1 : No
39	Not Used			<b>Re-zero when Changing Scale **2</b> 0 : No 1 : Yes

**NOTE :** \*\*1 Actuation weight condition is used for (a) Weight Check Output, (b) Holding Function, (c) Unit Weight Clear, and (d) Auto Printing (Build-in Printer).

\*\*2 When SPEC39 BIT0 set to 0, then SPEC38 BIT0 must be 0.

**REMARK: All "Not Used" BIT must be set to 0.**

## 7. CALIBRATION (Version 0.42 and above)

## 7.1 ZERO AND SPAN CALIBRATION

Please turn on the SPAN SWITCH before proceed. (If SPEC 32 bit 3 is 1, ignore the span switch.)

Operation	Display			Remarks
	Main(W)	Sub-1(UW)	Sub-2(Q)	
	S-On			Turn on the span switch.
[REZERO] + [8][7][1][5]	W CAL	Select Unit	Go	to calibration mode.
[ * ]	W CAL	Select Unit	Select weight unit: kg, lb, oz, dwt, g	
[ # ]	W CAL	Increment	0	Enter the increment in step of 1, 2, 5 or 10. For this exmple, we will use capacity 6kg and increment 0.001 using display resolution 1/6000. *
[0].[0][0][1]		Increment	0.001	Enter the increment 0.001
[ # ]	W CAL	Capacity	0 To	enter the capacity weight of the platform.
[6].[0][0][0]	W CAL	Capacity	6.000	Enter the full capacity weight of the platform.
[ # ]	CAL 0	Remove	Weight	Zero point calibration. Remove weight from platform.
If using actual capacity weight	CAL SP	Weight	6.000	Span Calibration. Put full capacity weight on platter.
Else enter the weight for calibration	CAL SP	Weight	5.000	Span Calibration for partial capacity weight. Enter the weight to calibrate. E.g. 5kg.
[ # ]	-----	-----	-----	Span Calibrating.
	Ir Count	500000	745000	After a few seconds, you will see t he internal count at Sub-1 and A/D count at Sub-2.
[MODE]	S-On			Back to Span On mode.
	0.0000	0	0	Poke the span switch to return to weighing mode.

- Calibration Setting
- Eg 6kg with display resolution 1/6000
- Increment =  $6 * (1/600) = 0.001$
- The last digit of the increment must be in 1,2,5,10

## 7.2 INTERNAL COUNT / AD COUNT DISPLAY

OPERATION	DISPLAY			REMARKS
	Main(W)	Sub-1(UW)	Sub-2(Q)	
[REZERO]	88888	88888	888888	
[REZERO][*][*] [+]		0	50000	Enter [0][0][9] while depressing the [REZERO] key. Unit Weight window will display the Internal Count and the Quantity window will display the A/D count.
[MODE]	PROG	PLU	Count 0	Press [MODE] key to escape from maintenance mode to weighing mode.
[MODE]	0.0000	0	0	Depressing the Span Switch switches to the weighing mode.

## 8 FLASH DOWNLOADING

There are 2 types of downloading:

- i) User Mode Downloading -- this mode of flash downloading is used when upgrading the indicator software
- ii) Boot Mode Downloading -- this mode of flash downloading is used when the CPU is brand new or flash program is lost due to unforeseen circumstances.

There are 2 methods of downloading:

- i) MS DOS Version.
- ii) Windows Version.

User can choose either of the 2 methods.

### 8.1 DOS Version

Do these steps before proceed :

- a) Make a directory eg **DI 80 on the PC**. Copy the program **FAST80.EXE** onto the created directory **DI 80**.
- b) Copy the DI 80 main software **DI80.MOT** (hex file) on to the directory **DI 80**.
- c) Connect DI 80 via SIO1 using RS232 cable to COM 1 or 2 of the PC.

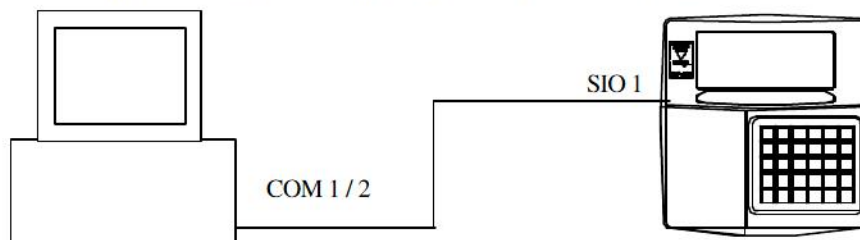

#### 8.1.1 USER MODE Downloading

- 1) Switch the option switch to **USER** mode on the DI 80.  
(This switch is accessible by removing the printer module. See below)

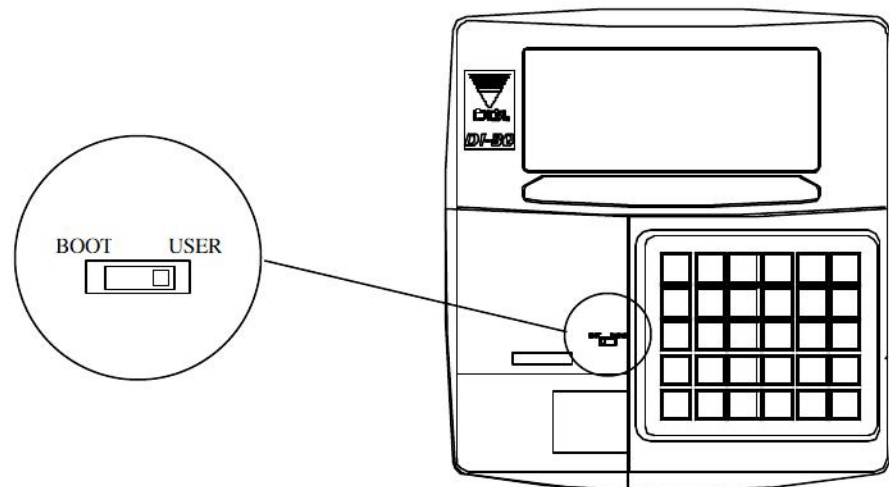

- 2) While pressing [REZERO] + [#] button together, press the [ON/OFF] button.  
The following will be shown on the indicator screen :



```
FLASH
FLASH DOWNLOAD
```

- 3) Click on the **FAST80.EXE** in the directory **DI80**.  
The following will be shown on the monitor:

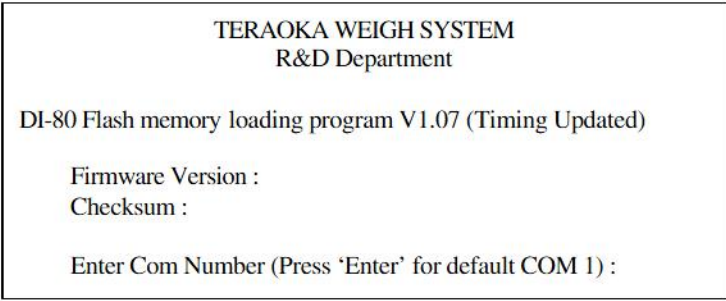

```
TERAOKA WEIGH SYSTEM
R&D Department

DI-80 Flash memory loading program V1.07 (Timing Updated)

Firmware Version :
Checksum :

Enter Com Number (Press 'Enter' for default COM 1) :
```

- 4) Enter the COM number or just press 'ENTER' if using COM 1.  
The following will be shown on the monitor :

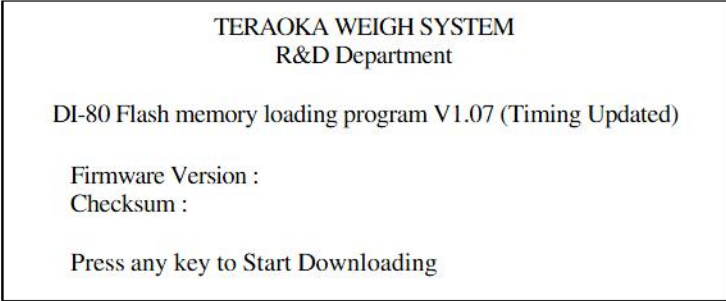

```
TERAOKA WEIGH SYSTEM
R&D Department

DI-80 Flash memory loading program V1.07 (Timing Updated)

Firmware Version :
Checksum :

Press any key to Start Downloading
```

- 5) Press any key on the keyboard when ready to download.  
The following will be shown on the monitor :

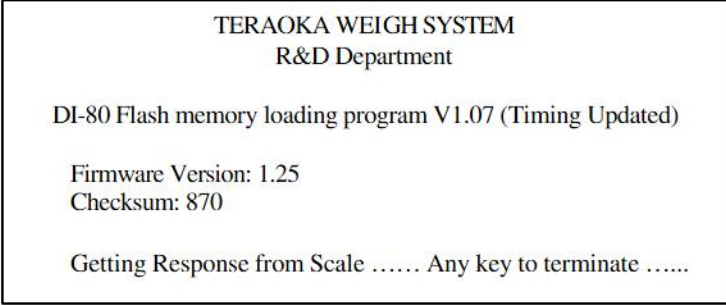

```
TERAOKA WEIGH SYSTEM
R&D Department

DI-80 Flash memory loading program V1.07 (Timing Updated)

Firmware Version: 1.25
Checksum: 870

Getting Response from Scale ..... Any key to terminate .....
```

- 6) If software is being loaded into DI 80 previously, it will be erased.  
The following will be shown on the monitor :

```

                TERAOKA WEIGH SYSTEM
                R&D Department

DI-80 Flash memory loading program V1.07 (Timing Updated)

Firmware Version: 1.25
Checksum 870

Erasing Flash ..... Please Wait .....

```

- 7) After a few seconds, the control program will start to download.  
The following will be shown on the monitor :

```

                TERAOKA WEIGH SYSTEM
                R&D Department

DI-80 Flash memory loading program V1.07 (Timing Updated)

Firmware Version: 1.25
Checksum: 870

Loading Control Program ..... Any key to terminate

```

\* Control program is a program to help the DI 80 to download the application program.

- 8) After the control program finish downloading, the application programme will start to download.  
The following will be shown on the monitor :

```

                TERAOKA WEIGH SYSTEM
                R&D Department

DI-80 Flash memory loading program V1.07 (Timing Updated)

Firmware Version: 1.25
Checksum: 870

Loading Application Programme ..... Any key to terminate

20 lines output to DI-80

```

- 9) The number of lines will be running until the end of line of the application program.  
A transmission end message "Download Completed" will appear after the download is finished.
- 10) After the process had completed, turn "Off" then "On" the indicator to see that the software version had been changed.

### 8.1.2 BOOT MODE Downloading

- 1) Switch the option switch to **BOOT** mode on the DI 80 and turn "On" the power only.
- 2) Repeat step 3 to 9 of USER MODE Downloading.
- 3) After finish downloading, turn "Off" the power and switch the OPTION switch to **USER** then turn "On" the power.

## 8.2 Window Version

Do these steps before proceed :

- a) Make a directory eg **DI 80 on the PC**. Copy the program **FAST80w.EXE** on to the created directory **DI 80**.
- b) Copy the DI 80 main software **DI80.MOT** (hex file) on to the directory **DI 80**.
- c) Connect DI 80 via SIO1 using RS232 cable to COM 1 or 2 of the PC.  
(See Diagram above on page 16).

### 8.2.1 USER MODE Downloading

- 1) Switch the option switch to **USER** mode on the DI 80.  
(This switch is accessible by removing the printer module. See above on page 16)
- 2) While pressing [REZERO] + [#] button together, press the [ON/OFF] button.  
The following will be shown on the indicator screen :



- 3) Click on the **FAST80w.EXE** in the directory **DI80**.  
The following will be shown on the monitor:

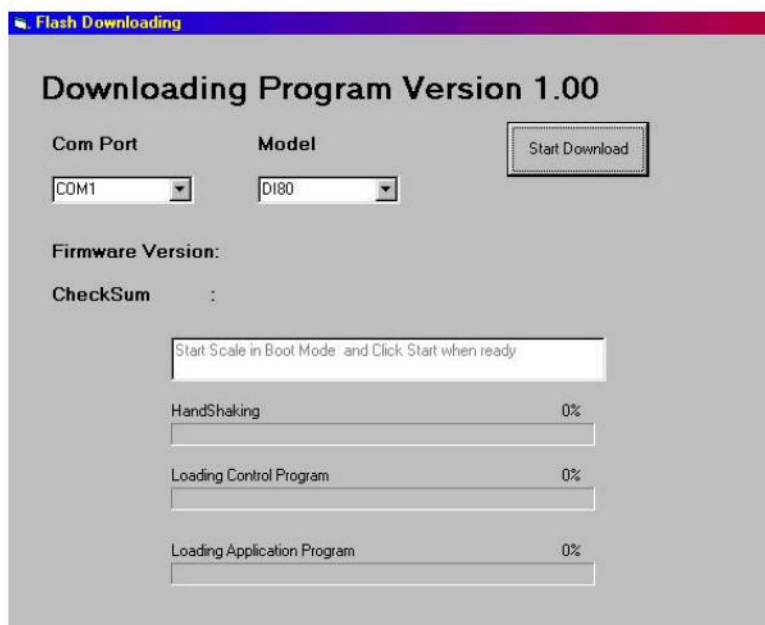

- 4) Activate the download by clicking on the <Start Download> icon. The program will run automatically by searching for the indicator software and detecting the connection with the indicator and download the control program and the application program.
- 5) After the process had completed, turn “Off” then “On” the indicator to see that the software version has been changed.

### 8.2.2 **BOOT MODE Downloading**

- 1) Switch the option switch to **BOOT** mode on the DI 80 and turn “On” the power only.
- 2) Repeat step 3 to 4 of USER MODE Downloading.
- 3) After finish downloading, turn “Off” the power and switch the OPTION switch to **USER** then turn “On” the power.

## 9. PC / PRINTER CONNECTION

### 9.1 GENERAL SPECIFICATION

Baud rate : 1200 / 2400 / 4800 / 9600 bps  
 Data length : 7 bits / 8 bits  
 Parity : None / Odd / Even  
 Stop bit : 1 bit / 2 bits  
 Printer type : COSTAR LabelWriter SE 250  
                   ELTRON Thermal printer LP2622

### 9.2 OUTPUT DATA FORMAT

a) With Header

HEADER	DATA	CR	HEADER	.....	CR	LF
--------	------	----	--------	-------	----	----

b) Without Header

DATA	CR	DATA	CR	.....	CR	LF
------	----	------	----	-------	----	----

#### 9.2.1 HEADER WITH CODE

Header Code	ASCII Code	Data	Header Code	ASCII Code	Data
0	30	Net weight	G	47	Set point 1 (Qty)
1	31	Unit weight	H	48	Set point 2
2	32	Quantity	I	49	Total quantity
3	33	ID code	K	4B	Inventory
4	34	Tare weight	M	4D	Parts no
8	38	Total weight	N	4E	Parts name
A	41	Gross weight	V	56	Scale no
B	42	Status	Q	51	Set point 3
C	43	Date and time	X	58	Set point 4
F	46	Set point 1 (Weight)			

#### 9.2.2 HEADER WITH TITLE

Data	Title	Data	Title
Net weight	NET WEIGHT	Set point 2	SET P2
Unit weight	UNIT WEIGHT	Total weight	TOTAL WEIGHT
Quantity	QUANTITY	Total quantity	TOTAL QUANTITY
ID code	ID CODE	Inventory	INVENTORY
Tare weight	TARE	Parts no	PART NO
Gross weight	GROSS WEIGHT	Parts name	PART NAME
Status	STATUS	Scale no	SCALE NO
Date and time	DATE & TIME	Set point 3	SET P3
Set point 1 (Weight)	SET P1(W)	Set point 4	SET P4
Set point 1 (Qty)	SET P1(Q)		

### 9.3 DATA

- |                   |                      |                    |
|-------------------|----------------------|--------------------|
| i) ID code        | vi) Tare weight      | xi) Inventory      |
| ii) Set point     | vii) Quantity        | xii) Part name     |
| iii) Gross weight | viii) Total quantity | xiii) Scale no.    |
| iv) Net weight    | viiii) Status *      | xiv) Date and time |
| v) Unit weight    | x) Part no.          |                    |

**\* REMARK :**

Status data as below :

Bit	If set to 1	If set to 0
0	Positive weight	Negative weight
1	Weight stable	Weight unstable
2	Output key in data	Others
3	Output by + key	Others
4	Output by – key	Others
5	Output by * key	Others
6	Output total	Others
7	Always set to “1”	

### 9.4 TRANSMISSION PROTOCOL

#### 9.4.1 Remote Trigger

Upon received of ENQ from host, DI-80 will send out weight information

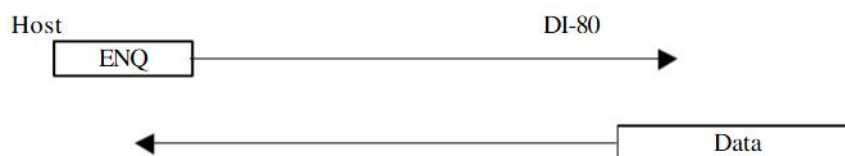

#### 9.4.2 Continuous mode

DI-80 will send out weight data at a fixed interval



#### 9.4.3 Manual mode

DI-80 will send out weight data when user depress the PRINT key.



#### 9.4.4 Continuous and Manual mode

This is a combination of continuous mode and manual mode.

9.5 WIRE CONFIGURATION

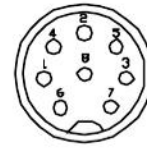
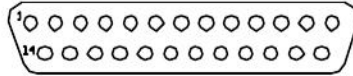
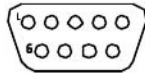

9 PIN D-SUB CONNECTOR BACK VIEW (FEMALE) 25 PIN D-SUB CONNECTOR BACK VIEW (FEMALE) 8 PIN DIN PLUG BACK VIEW (MALE)

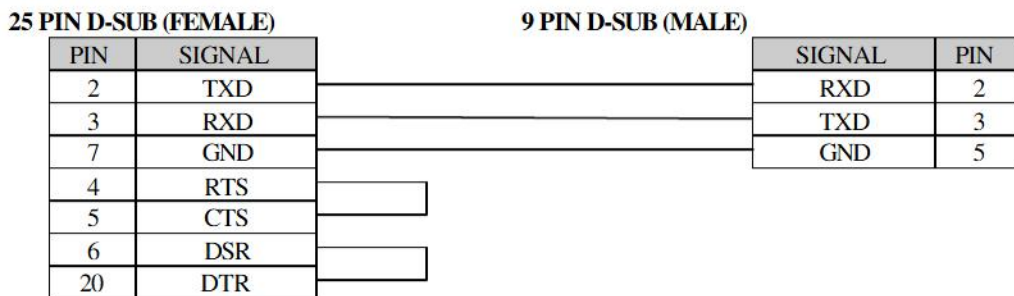
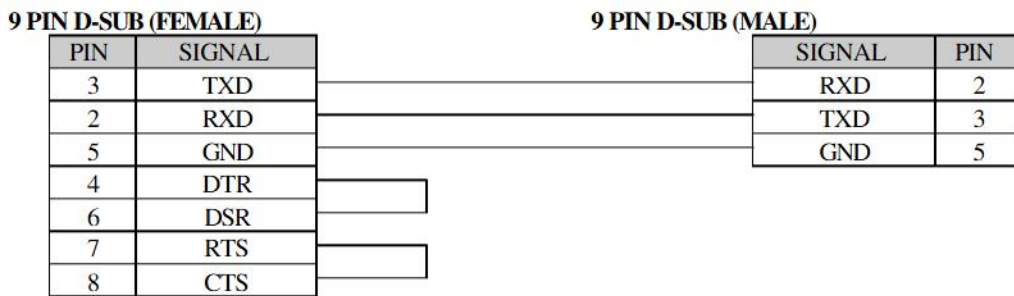
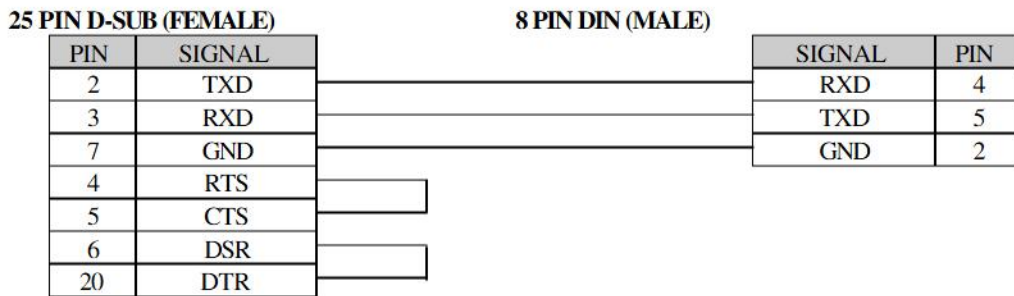
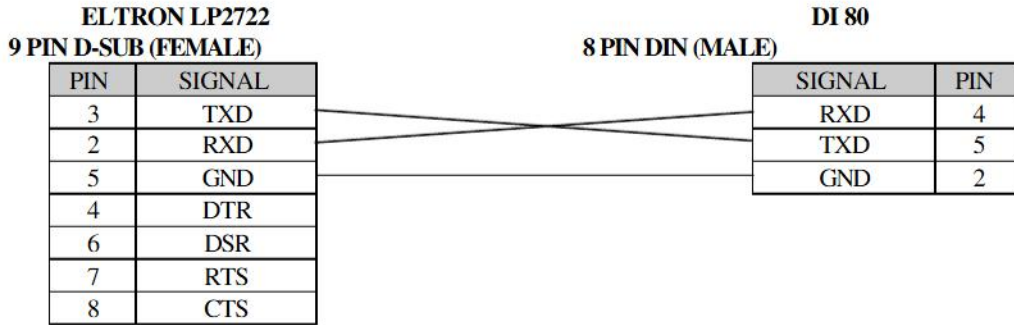

## 9.6 PC / PRINTER RS232C CONNECTION SPEC SETTING

Setting on DI 80 under [Re-Zero]+[141] :

If using SIO 1 :

<b>RS232 Continue Sending Rate To PC (PC connection only)</b>	SPEC 6 Bit 1
<b>Type Of Devices *</b>	SPEC 8 Bit 0, 1 and 2
<b>SIO 1 Connection</b>	SPEC 8 Bit 3
<b>SIO 1 Baud Rate</b>	SPEC 9 Bit 0, 1 and 2
<b>SIO 1 Data Length</b>	SPEC 9 Bit 3
<b>SIO 1 Parity</b>	SPEC 10 Bit 0 and 1
<b>SIO 1 Send Header As **</b>	SPEC 10 Bit 2
<b>SIO 1 Send With Header **</b>	SPEC 10 Bit 3
<b>SIO 1 Stop Bits</b>	SPEC 11 Bit 1
<b>SIO 1 Mode Of Operation **</b>	SPEC 11 Bit 2 and 3

If using SIO 2 :

<b>RS232 Continue Sending Rate To PC (PC connection only)</b>	SPEC No. 6 Bit 1
<b>Type Of Devices *</b>	SPEC No. 50 Bit 0, 1 and 2
<b>SIO 2 Connection</b>	SPEC No. 50 Bit 3
<b>SIO 2 Baud Rate</b>	SPEC No. 51 Bit 0, 1 and 2
<b>SIO 2 Data Length</b>	SPEC No. 51 Bit 3
<b>SIO 2 Parity</b>	SPEC No. 52 Bit 0 and 1
<b>SIO 2 Send Header As **</b>	SPEC No. 52 Bit 2
<b>SIO 2 Send With Header **</b>	SPEC No. 52 Bit 3
<b>SIO 2 Stop Bits</b>	SPEC No. 53 Bit 1
<b>SIO 2 Mode Of Operation **</b>	SPEC No. 53 Bit 2 and 3

If using SIO 3 :

<b>RS232 Continue Sending Rate To PC (PC connection only)</b>	SPEC No. 6 Bit 1
<b>Type Of Devices *</b>	SPEC No. 54 Bit 0, 1 and 2
<b>SIO 3 Connection (RS 485)</b>	SPEC No. 54 Bit 3
<b>SIO 3 Baud Rate</b>	SPEC No. 55 Bit 0, 1 and 2
<b>SIO 3 Data Length</b>	SPEC No. 55 Bit 3
<b>SIO 3 Parity</b>	SPEC No. 56 Bit 0 and 1
<b>SIO 3 Send Header As **</b>	SPEC No. 56 Bit 2
<b>SIO 3 Send With Header **</b>	SPEC No. 56 Bit 3
<b>SIO 3 Stop Bits</b>	SPEC No. 57 Bit 1
<b>SIO 3 Mode Of Operation **</b>	SPEC No. 57 Bit 2 and 3

### REMARKS:

\* Same device cannot be reselected again in SPEC 08, SPEC 50 and SPEC 54

\*\* Ignore these SPEC setting if device is barcode scanner.

## 9.7 BUILT-IN PRINTER

Setting on DI 80 under Re-Zero+[141] :

<b>Built-in Printer</b>	Set SPEC 13 Bit 3 to 1
<b>Line Thermal Head Printer (ALPS)</b>	Set SPEC 59 Bit 2 to 1
<b>Thermal Head Printer (Seiko)</b>	Set SPEC 59 Bit 2 to 0

\* Note :

For Line Thermal Head Printer, software needs to be at least V1.24

Printer Board Interface for Line Thermal Head Printer (ALPS) is TWB-02370-0

Printer Board Interface for Thermal Head Printer (Seiko) is TWB-02340-0

## 9.8 EXTERNAL PRINTER

DI 80 can connect with these external printer :

### 9.8.1 COSTAR SE 250

Setting on DI 80 :

Baud rate : 9600 bps  
 Data length : 8 bits  
 Parity : None  
 Stop bit : 1 bit  
 Type of device : SE 250  
 RS232 Output: By [ \* ], [ + ] and [ - ] key

### 9.8.2 ELTRON LP 2622

Setting on DI 80 :

Baud rate : 9600 bps  
 Data length : 8 bits  
 Parity : None  
 Stop bit : 1 bit  
 Type of device : LP 2622  
 RS232 Output: By [ \* ], [ + ] and [ - ] key

\* Note :

DI 80 will download some label formats to LP 2622 when power up. Owing to this, LP 2622 should connect to DI 80 when DI 80 power up. Also, make sure the printer has enough memory allocated for Form memory (at least 3K). Please refer to the printer manual.

## 10. BARCODE SCANNER CONNECTION

DI 80 can support these barcode scanners :

### RS232C TYPE

Pen scanner - ZEBEX ZB-800R  
Handheld scanner - PSC Quickscan scanner

### 10.1 GENERAL SPECIFICATION

Baud rate : 1200 / 2400 / 4800 / 9600 bps  
Data length : 7 bits / 8 bits  
Parity : None / Odd / Even  
Stop bit : 1 bit / 2 bits  
Barcode type : CODE 39

### 10.2 DEFAULT SPEC OF BARCODE SCANNER

#### Pen Scanner, ZB-800R

9600 bps, 8 bits, None parity and 1 stop bit

#### Handheld Scanner, PSC Quickscan

9600 bps, 7 bits, None parity and 1 stop bit

### 10.3 PIN CONFIGURATION

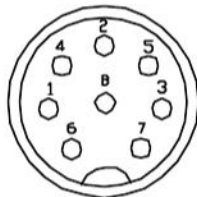

8 PIN DIN PLUG FOR  
BARCODE SCANNER  
(BACK VIEW)

PIN	SIGNAL	ZB-800R	Quickscan	PSC QuickScan 6000
2	GND	Yellow	Black	Black
4	RXD	Grey	Orange	Blue
5	TXD	Brown	White	Orange
6	CTS	White	Blue	Yellow (Not Used)
7	RTS	Green	Yellow	White (Not Used)
8	VCC	Red	Red	Red

### 10.4 INPUT DATA FORMAT

With Header

Header	Data	CR
--------	------	----

Without header (Can scan ID Code only)

Data	CR
------	----

The barcode scanner can be use in the following operation :

#### 10.4.1 OPERATION Mode :

UNIT WEIGHT            ID CODE  
TARE WEIGHT            QUANTITY

#### 10.4.2 PROGRAM Mode :

ID CODE                                    UNIT WEIGHT                    INVENTORY  
PART NO.                                    TARE WEIGHT  
PART NAME                                    SET POINTS

Header Code	ASCII Code	Data	Header Code	ASCII Code	Data
1	31	Unit weight	H	48	Set point 2
2	32	Quantity	I	49	Total quantity
3	33	ID code	K	4B	Inventory
4	34	Tare weight	M	4D	Part no.
A	41	Gross weight	N	4E	Part name
F	46	Set point 1 (W)	Q	51	Set point 3
G	47	Set point 1 (Q)	X	58	Set point 4

#### 10.4.3 COMMAND CODE

The barcode scanner can also scan command to DI 80 but it must have a header Z in front.

Header : Z	Command	CR
------------	---------	----

Z + Command	Function	Z + Command	Function
Z0	Rezero	Z5	Tare
Z1	Print	Z6	Clear
Z2	Unit weight clear	ZS1	Scale 1
Z3	Plus	ZS2	Scale 2
Z4	Minus		

## 10.5 BARCODE SCANNER CONNECTION SPEC SETTING

If using SIO 1 :

## SPEC No. 8 Bit 0, 1 and 2 Type Of Devices \*

000	<u>Barcode scanner</u>	010	LP 2622	100	Ethernet (Not ready)
001	PC	011	SE 250		

## SPEC No. 8 Bit 3 SIO 1 Connection

0	No	1	Yes
---	----	---	-----

## SPEC No. 9 Bit 0, 1 and 2 SIO 1 Baud Rate

000	1200	010	4800	100	19200
001	2400	011	9600	101	38400

## SPEC No. 9 Bit 3 SIO 1 Data Length

0	7 bits	1	8 bits
---	--------	---	--------

## SPEC No. 10 Bit 0 and 1

## SIO 1 Parity

00	No	10	Not used
01	Odd	11	Even

## SPEC No. 11 Bit 1

## SIO 1 Stop Bits

0	1 bit	1	2 bits
---	-------	---	--------

If using SIO 2 :

## SPEC No. 50 Bit 0, 1 and 2

## Type Of Devices \*

000	<u>Barcode scanner</u>	010	LP 2622	100	Ethernet (Not ready)
001	PC	011	SE 250		

## SPEC No. 50 Bit 3

## SIO 2 Connection

0	No	1	Yes
---	----	---	-----

## SPEC No. 51 Bit 0, 1 and 2

## SIO 2 Baud Rate

000	1200	010	4800	100	19200
001	2400	011	9600	101	38400

## SPEC No. 51 Bit 3

## SIO 2 Data Length

0	7 bits	1	8 bits
---	--------	---	--------

## SPEC No. 52 Bit 0 and 1

## SIO 2 Parity

00	No	10	Not used
01	Odd	11	Even

## SPEC No. 53 Bit 1

## SIO 2 Stop Bits

0	1 bit	1	2 bits
---	-------	---	--------

**If using SIO 3 :****SPEC No. 54 Bit 0, 1 and 2**

000	Barcode scanner
001	PC

**Type Of Devices\***

010	LP 2622
011	SE 250

100 Ethernet (Not ready)

**SPEC No. 54 Bit 3**

0	No
---	----

**SIO 3 Connection**

1	Yes
---	-----

**SPEC No. 55 Bit 0, 1 and 2**

000	1200
001	2400

**SIO 3 Baud Rate**

010	4800
011	9600

100	19200
101	38400

**SPEC No. 55 Bit 3**

0	7 bits
---	--------

**SIO 3 Data Length**

1	8 bits
---	--------

**SPEC No. 56 Bit 0 and 1**

00	No
01	Odd

**SIO 3 Parity**

10	Not used
11	Even

**SPEC No. 57 Bit 1**

0	1 bit
---	-------

**SIO 3 Stop Bits**

1	2 bits
---	--------

**\* REMARKS :**

Same device cannot be reselected again in SPEC 8, SPEC 50 and SPEC 54

**10.6 BARCODE SAMPLE**

The barcode formats is using CODE 39 type. Below are some command and data barcodes for testing purpose. If generate barcode using word processor, please add \* before and after the data to indicate the start and end of barcode. If generate by barcode software or barcode printer, it is not necessary as it will generate it own start and end of barcode.

REZERO

CLEAR

SCALE 1

**\* Z0 \*****\* Z6 \*****\* ZS1 \***

Z1

Z6

ZS1

SCALE 2

ID CODE

**SCALE 2****\* 312345678 \***

ZS2

312345678

PART NAME

**\* NABCDEF GH \***

NABCDEFGH

## 11. SET POINT CONNECTION

There can 2, 3 or 4 set point output depend by SPEC. It need an external voltage (5 ~ 29 V) to drive the set points.

### 11.1 PIN CONFIGURATION

PIN	SIGNAL
1	Set point 1
2	Set point 2
3	Set point 3
4	Set point 4
5	-
6	-
7	External voltage*
8	GND

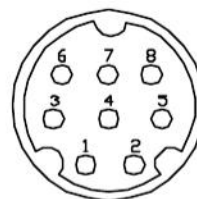

8 Pin Mini DIN Plug  
Front View

\* External voltage is from the range 5 to 29 V DC.

### 11.2 SET POINT SPEC SETTING

<b>SPEC No. 0 Bit 0</b>		<b>Set Point Display</b>	
0	No	1	Yes
<b>SPEC No. 7 Bit 0 and 1</b>		<b>Set Point Type</b>	
00	% Quantity	10	Quantity
01	% Weight	11	Weight
<b>SPEC No. 7 Bit 2</b>		<b>Set Point Latch</b>	
0	Latch	1	No latch
<b>SPEC No. 7 Bit 3</b>		<b>Set Point Buzzer</b>	
0	Yes	1	No
<b>SPEC No. 12 Bit 2 and 3</b>		<b>TTL Output</b>	
00	Holding output (WS+HOLD)	10	Checker output
01	Set point output	11	Disable
<b>SPEC No. 17 Bit 2</b>		<b>Buzzer On</b>	
0	When weight is within SP1 and SP2	1	When weight is outside SP1 and SP2
<b>SPEC No. 18 Bit 0, 1 and 2</b>		<b>Number Of Set Points</b>	
000	2 set points	010	4 set points
001	3 set points	011 ~ 111	Not used
<b>SPEC No. 18 Bit 3</b>		<b>Set Point TTL Output</b>	
0	Active low	1	Active high

### 11.3 SET POINT SET UP

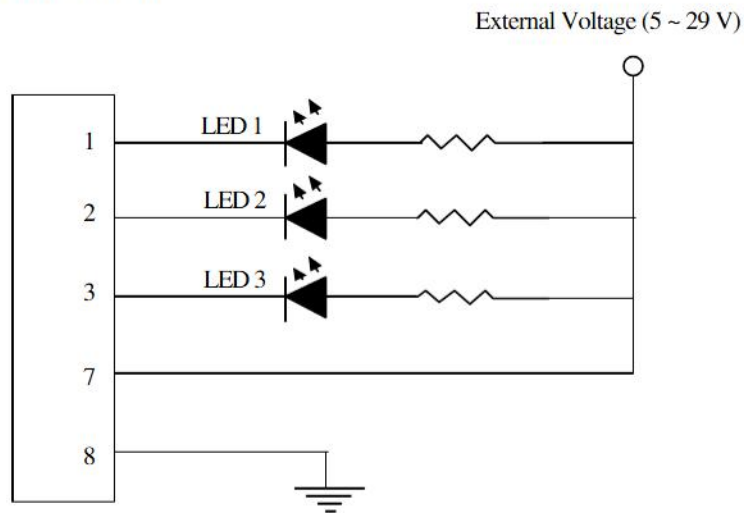

Below is a chart that show when the LEDs will be light up in latch and no latch condition as per above set up when set point is reach.

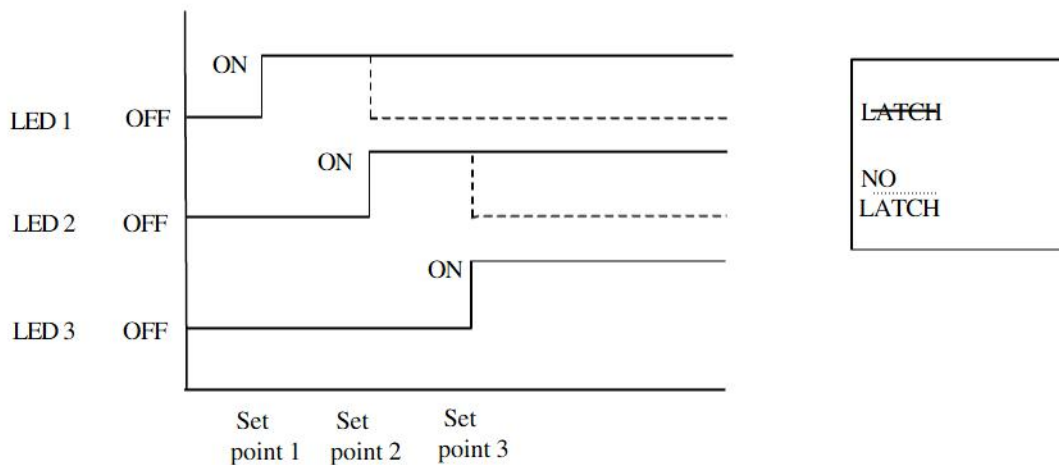

#### LATCHING

When set point 1 is reach e.g. set point 1 is set to 1,000 pcs and 1,000 pcs is reach or over, LED 1 will light up.

When set point 2 is reach, LED 1 and 2 would light up together.

When set point 3 is reach, LED 1, 2 and 3 would light up together.

#### NO LATCHING

When set point 1 is reach, LED 1 will light up while LED 2 and 3 will be off.

When set point 2 is reach, LED 2 will light up while LED 1 and 3 will be off.

When set point 3 is reach, LED 3 will light up while LED 1 and 2 will be off.

12. SELF TEST

There are 7 self test available for DI-80:

- a) RS 232 test
- b) RS 232 (optional board) test
- c) RS 485 (optional board) test
- d) Printer test
- e) SRAM1 test
- f) SRAM2 test
- g) TTL output test

OPERATION	DISPLAY			REMARKS
	Main (W)	Sub-1(UW)	Sub-2 (Q)	
[REZERO] + [0][8][9][3]	Prog			At PROG mode.
[+] or [-]	SELF	PRINTER	TEST	Select the testing hardware.
[*]	SELF	PLEASE	WAIT	To test the hardware selected.
After testing is completed, DI-80 will displayed test result	SELF	TEST or FOUND	OK	The screen will display the result of the test. It either display TEST OK or FOUND ERR.
	SELF		ERR	
[C]	SELF	PRINTER	TEST	Go back to the self test mode.
[*]	SELF	EXIT	SELF	Go to the display shown to exit.
	ProG	PLU COUNT	6	

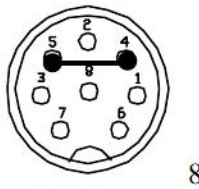

RS232 Tester Connector

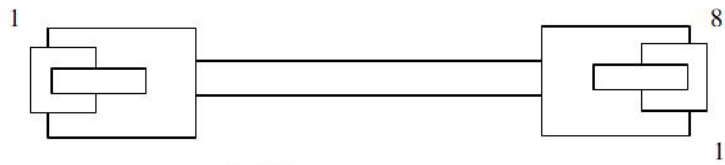

RS 485 Tester

Modular Connector

Modular Connector

PIN	SIGNAL	SIGNAL	PIN
1	IN+	OUT+	3
2	IN-	OUT-	4
3	OUT+	IN+	1
4	OUT-	IN-	2

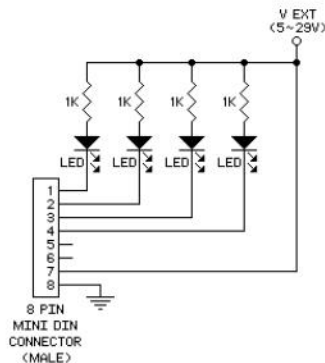

TTL output sample circuit

13. CIRCUIT DIAGRAM

13.1 DI 80 BLOCK DIAGRAM

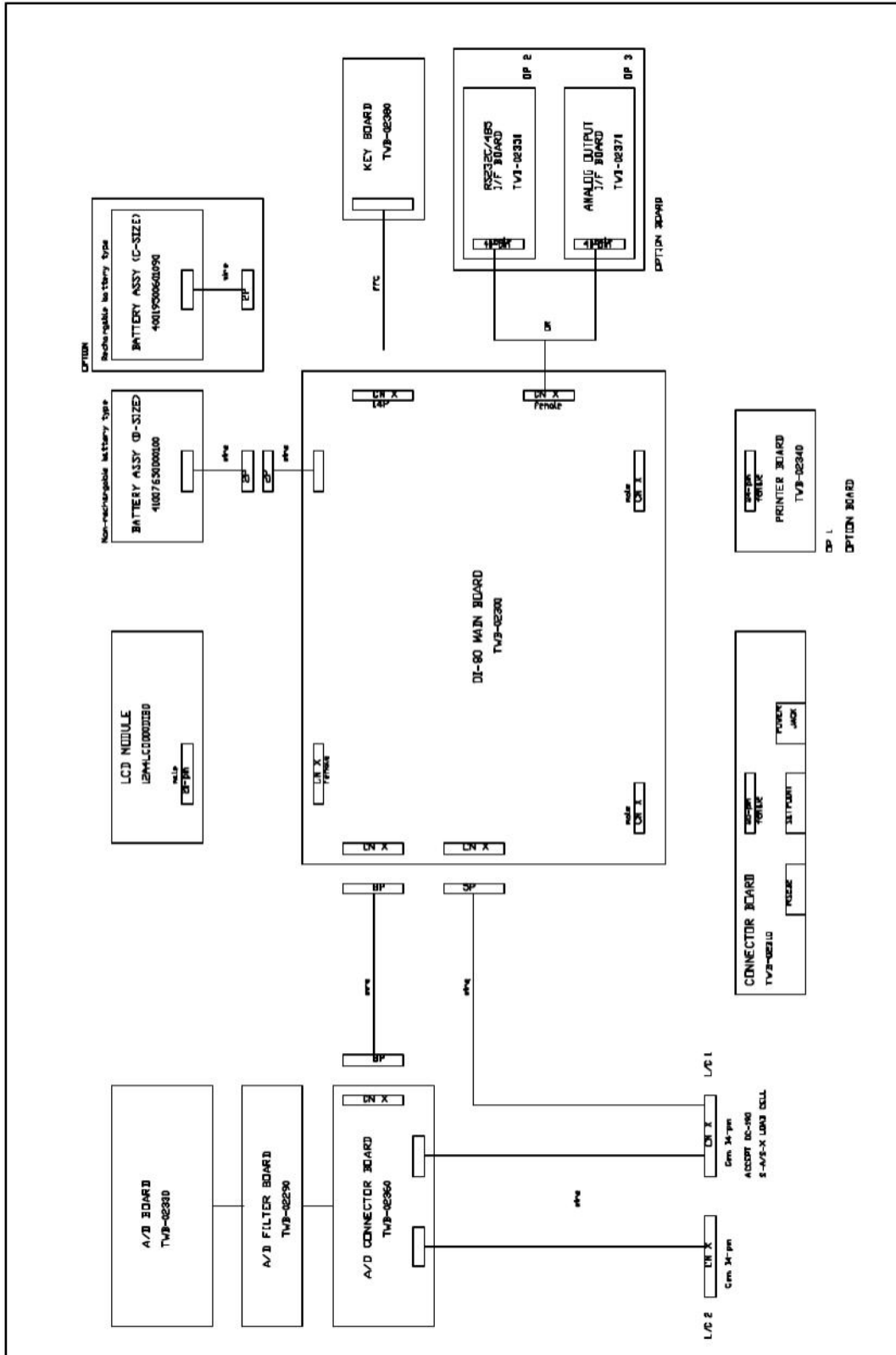



13.2 DI 80 MAIN BOARD TWB-02300-0 ( 2 OF 4 )

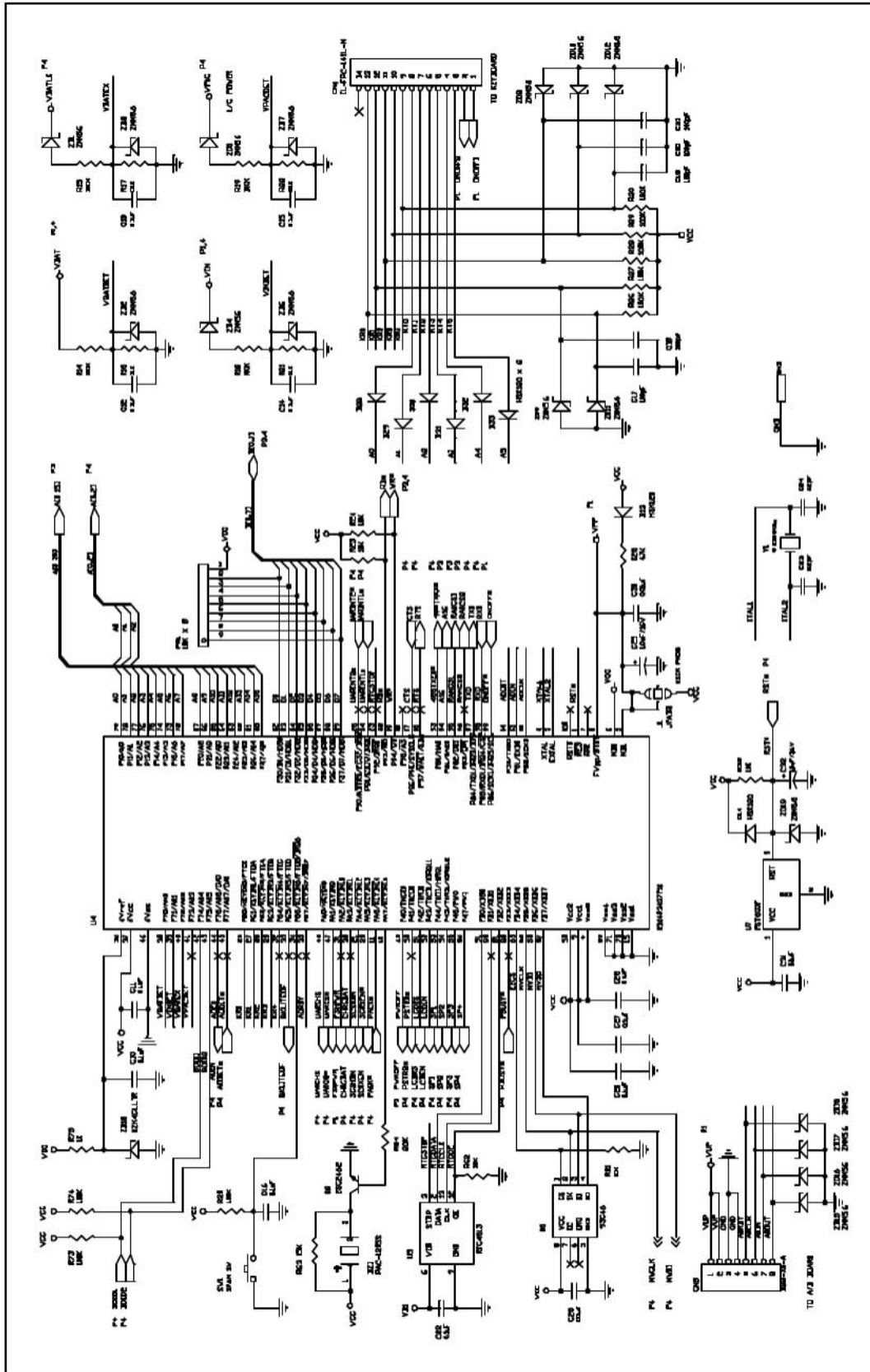

13.2 DI 80 MAIN BOARD TWB-02300-0 ( 3 of 4 )

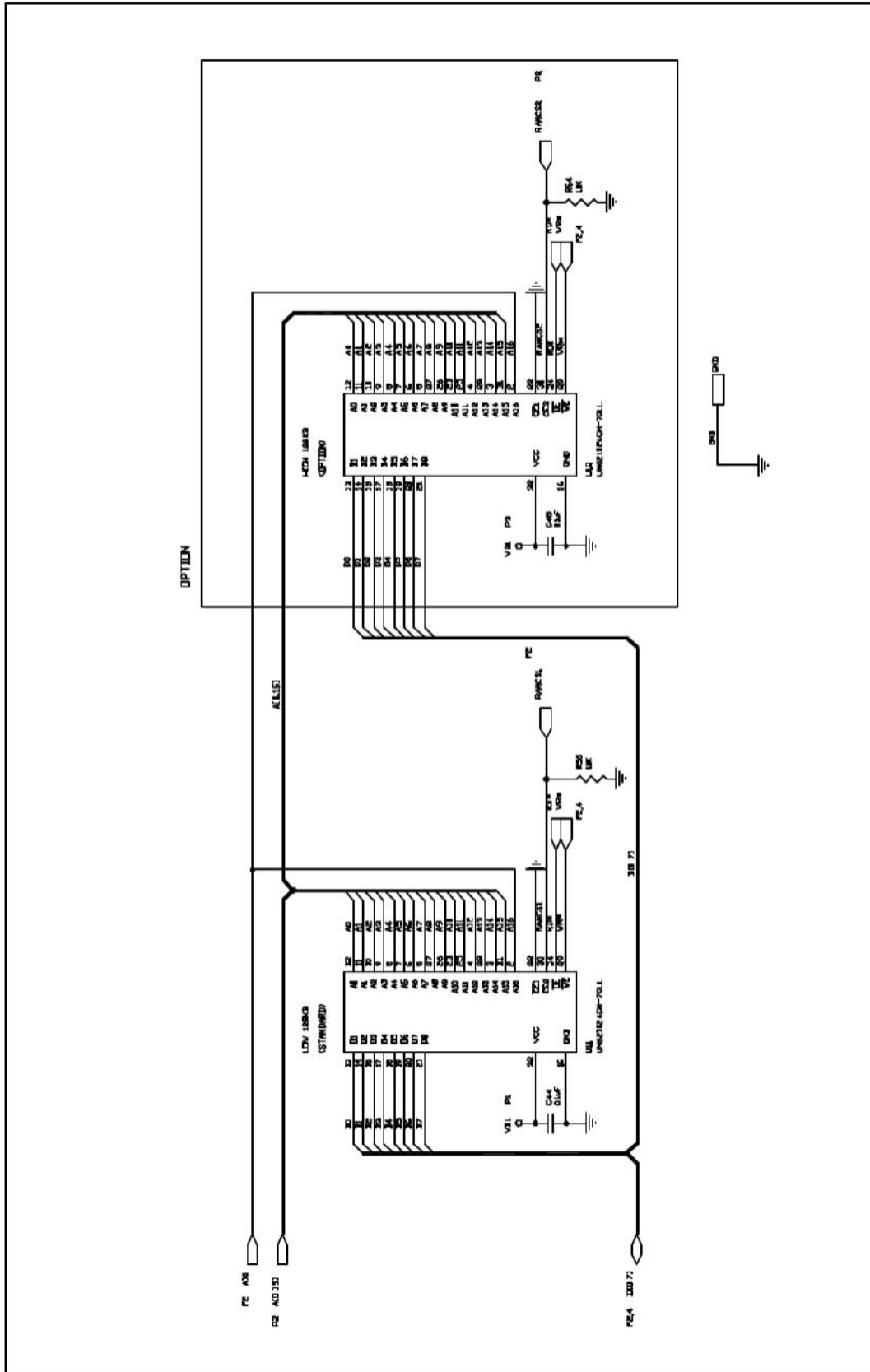

13.2 DI 80 MAIN BOARD TWB-0230-0 (4 of 4)

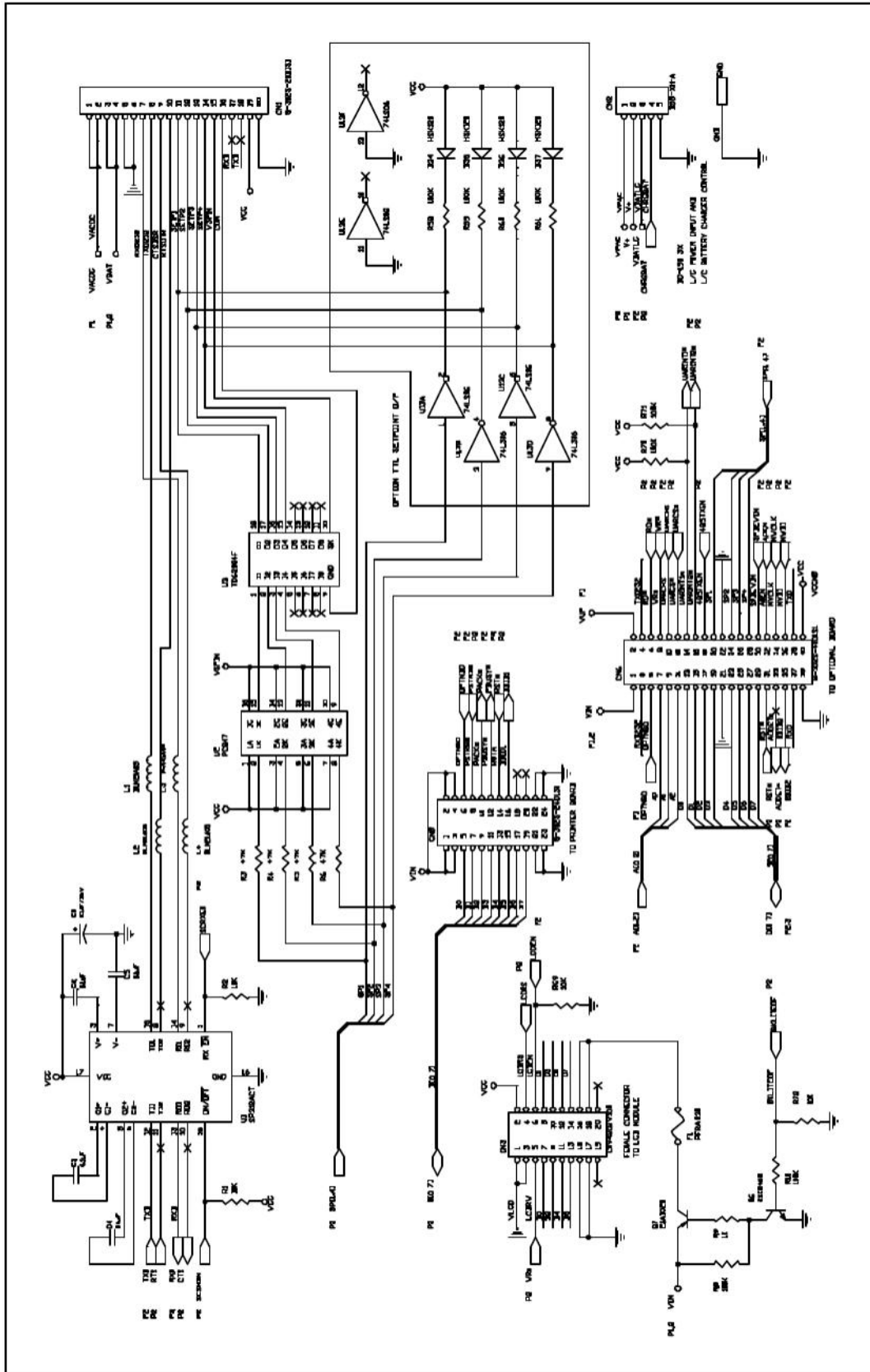

13.3 DI 80 A/D BOARD TWB-02330-0

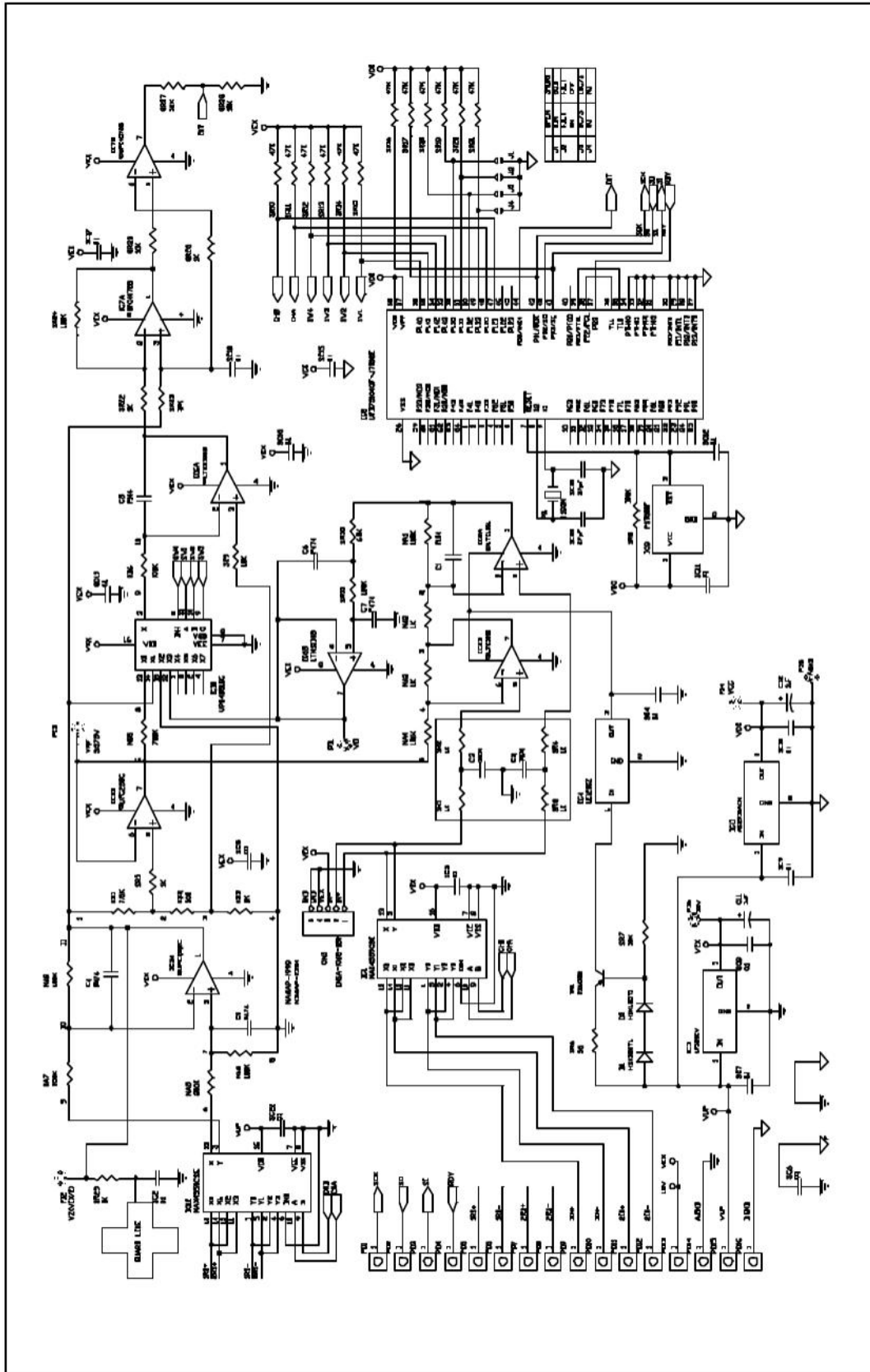

13.4 DI 80 A/D FILTER BOARD TWB-02290-0

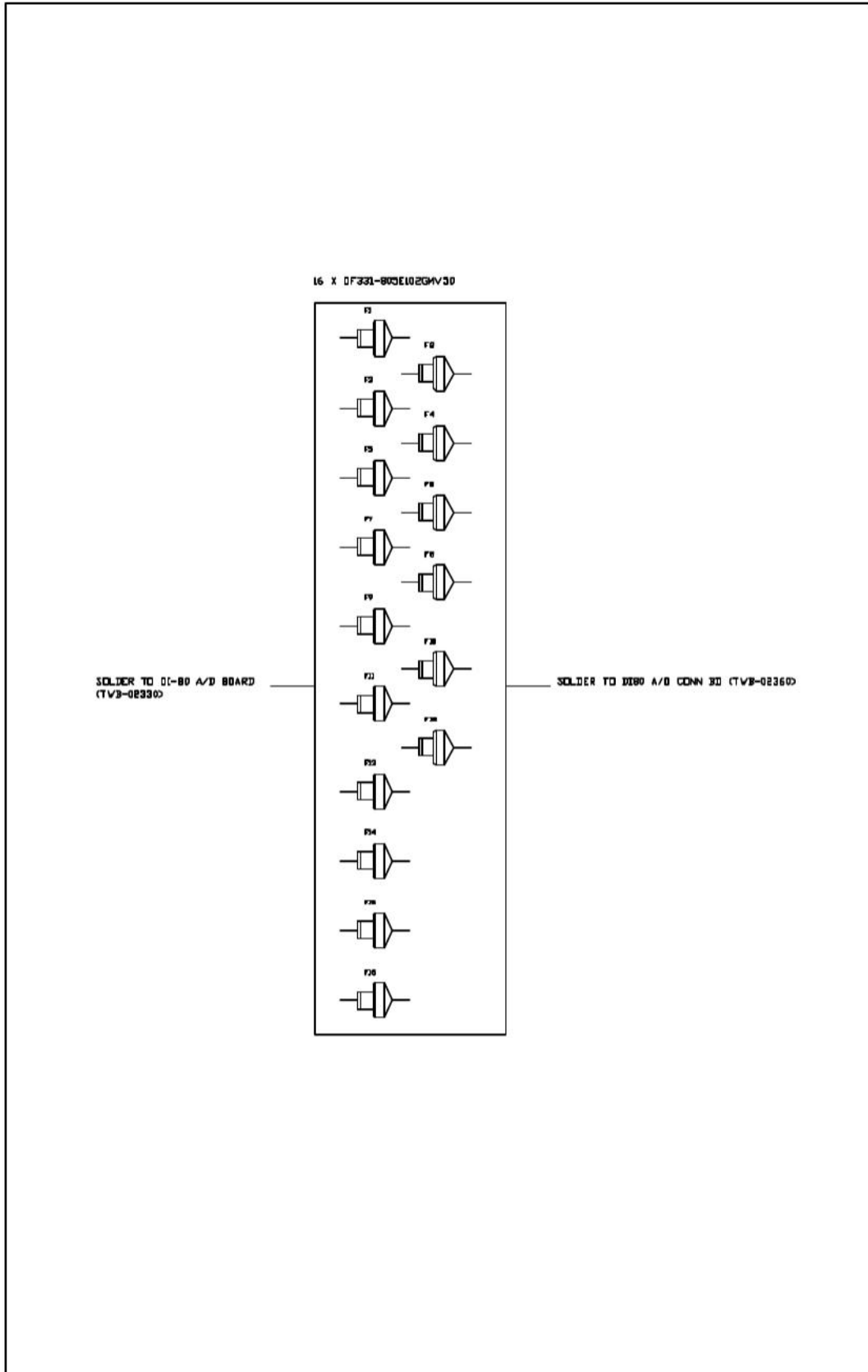

13.5 DI 80 A/D CONNECTOR BOARD TWB-02360-0

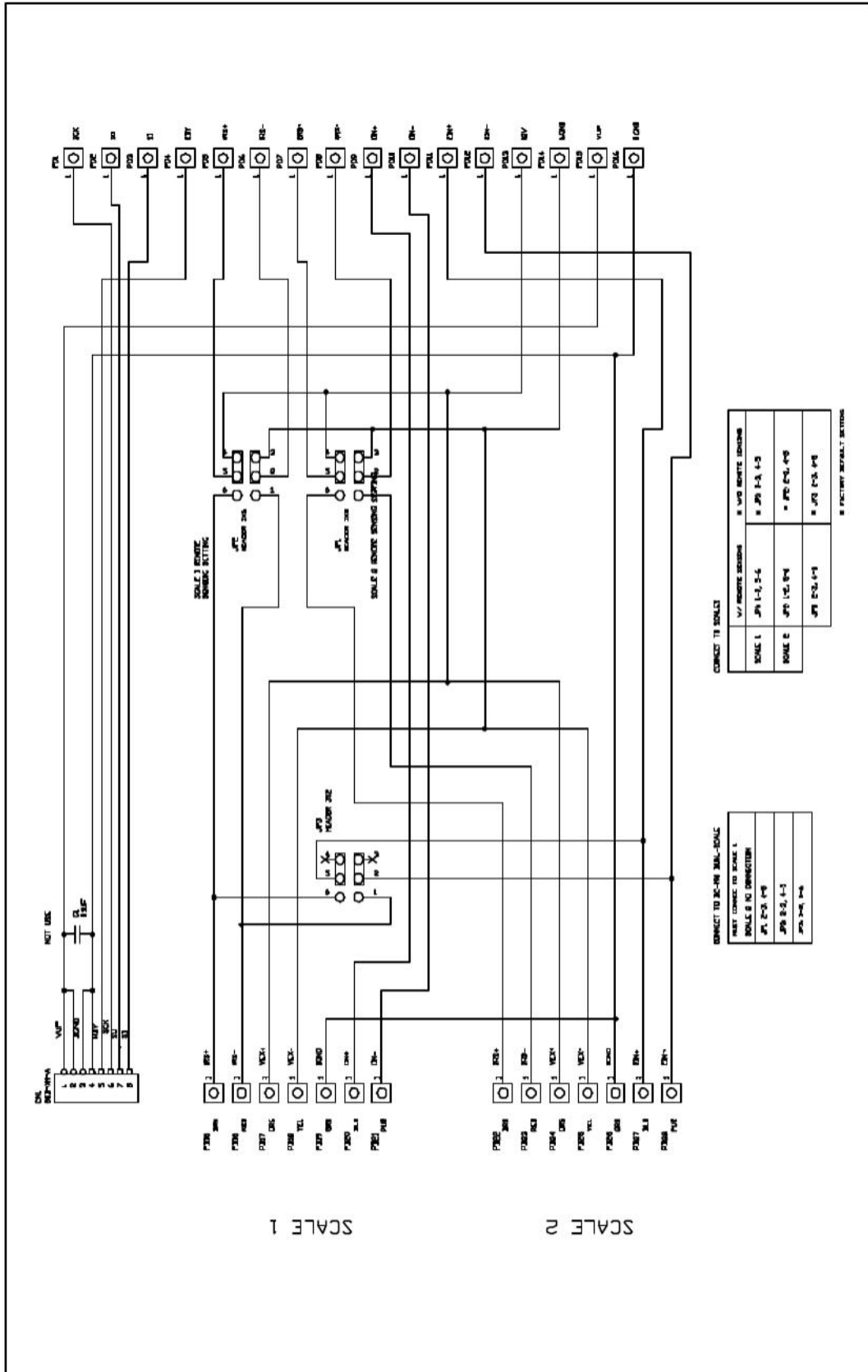









13.8c DI 80 OPTION BOARD 3- ANALOG INTERFACE BOARD TWB-02370-0

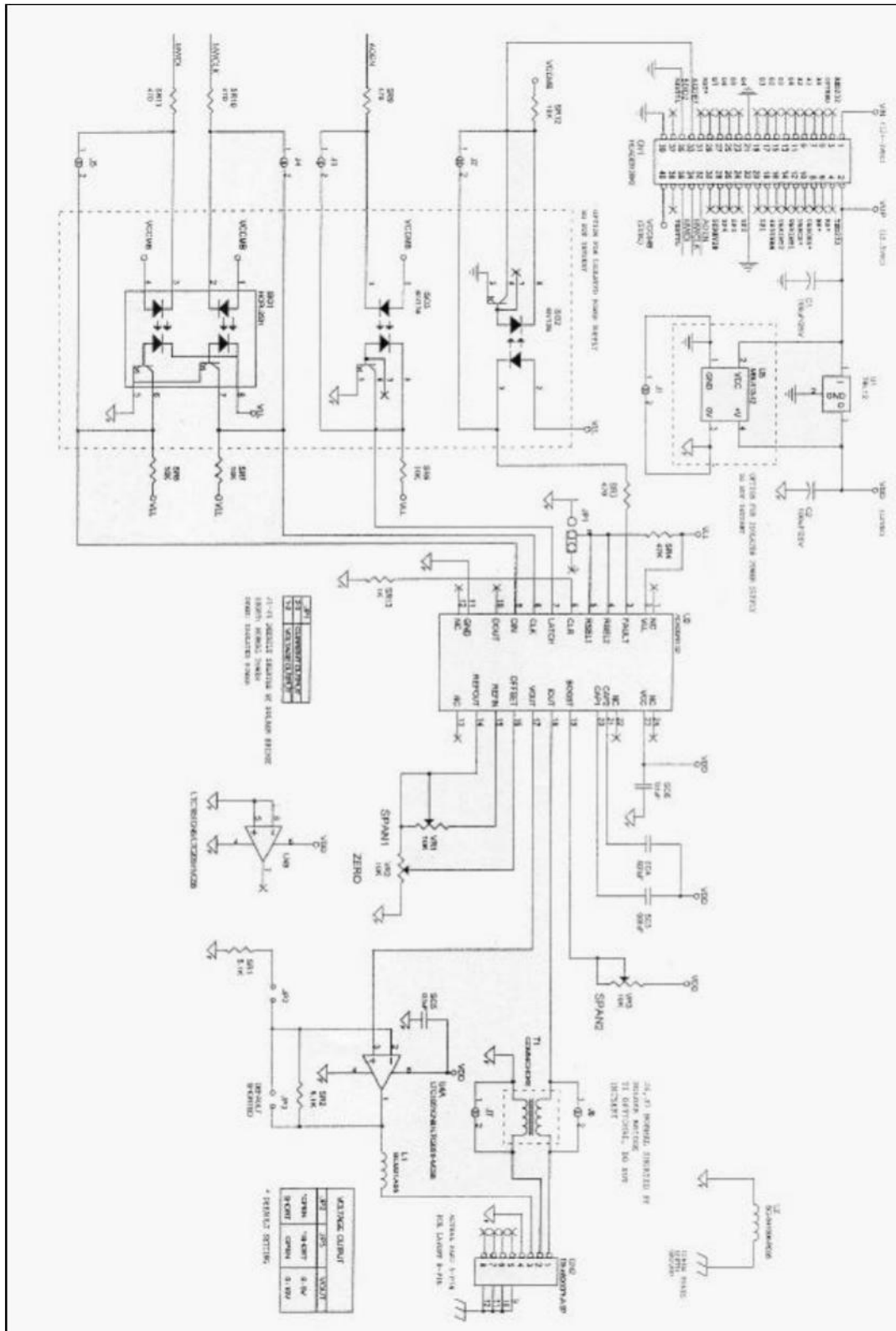

## 14. ANALOG INTERFACE BOARD

### 14.1 SPECIFICATION

This option board is used to transmit the analog weight data to the equipment that is controlled by DC current or voltage.

#### *Output mode:*

Only one output mode is available at the same time.

1. Current mode: output 4mA~20mA, current source
2. Voltage mode: output 0~5VDC or 0~10VDC

#### *Specifications:*

##### **Current Output Mode:**

Output Level: 4mA ~ 20mA effective range, maximum output range is 2mA ~ 22mA

Resolution: 1/2000 (or 0.01mA/step)

Load Resistance: 500Ω or less

Temperature Coefficient: TBD

Nonlinearity: TBD

Renewal of Data: Synchronous with display

##### **Voltage Output Mode:**

Output Level: 0 ~ 5V or 0 ~ 10V

Resolution: 1/2000 (or 2.5mV/step, 5mV/step)

Temperature Coefficient: TBD

Nonlinearity: TBD

Renewal of Data: Synchronous with display

#### *Analog Output Scaling*

##### **1. Current Output Mode**

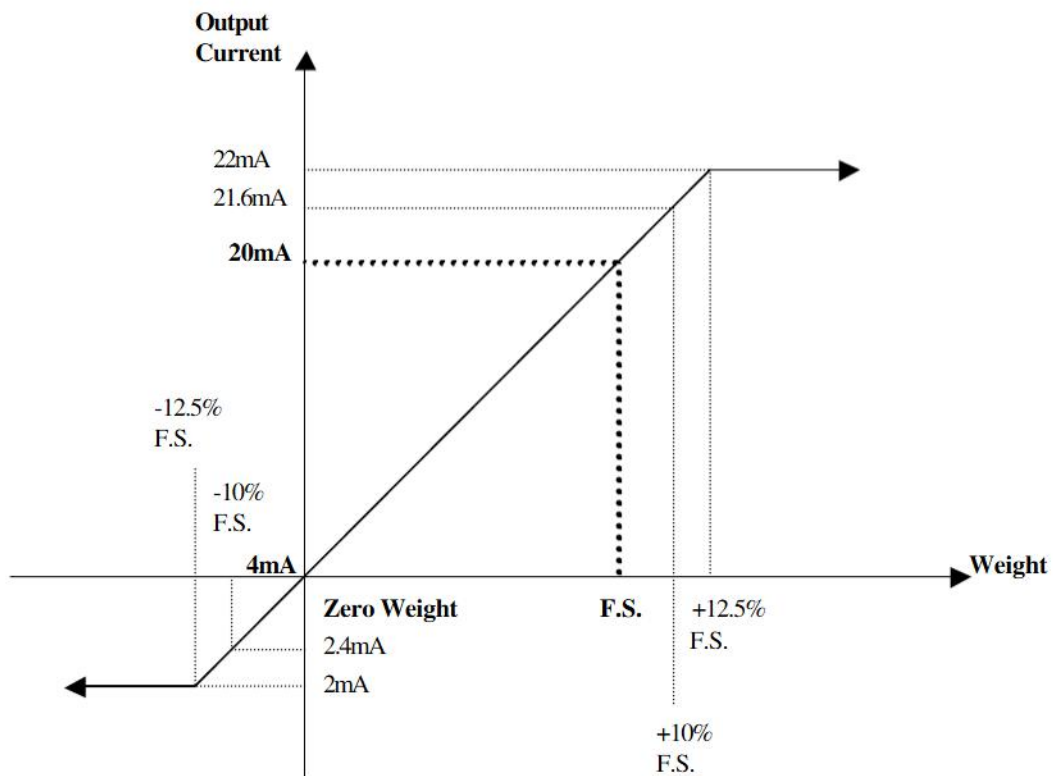

## 2. Voltage Output Mode: 0 ~ 5V

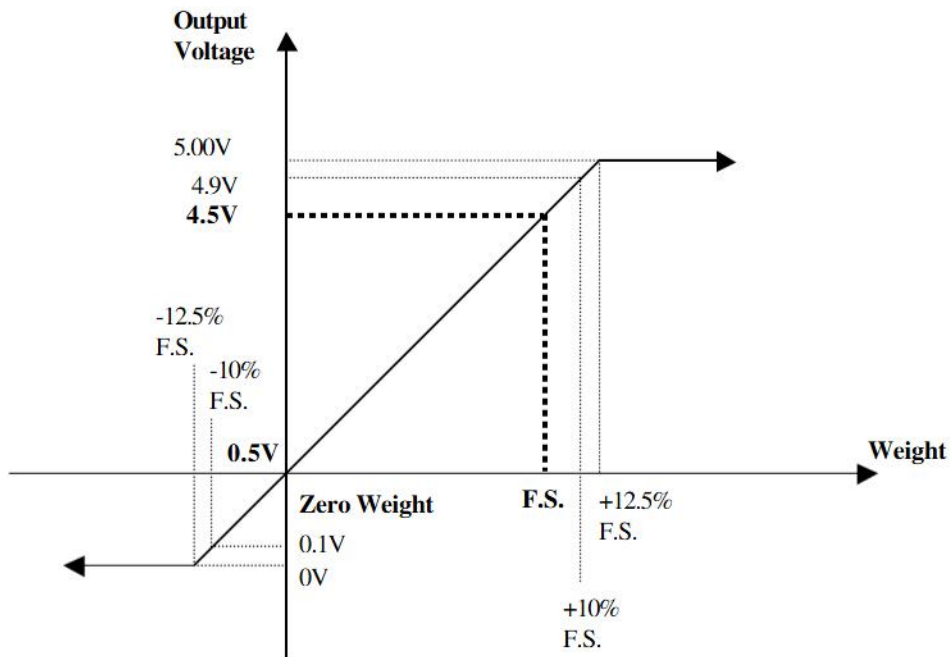

## 3. Voltage Output Mode: 0 ~ 10V

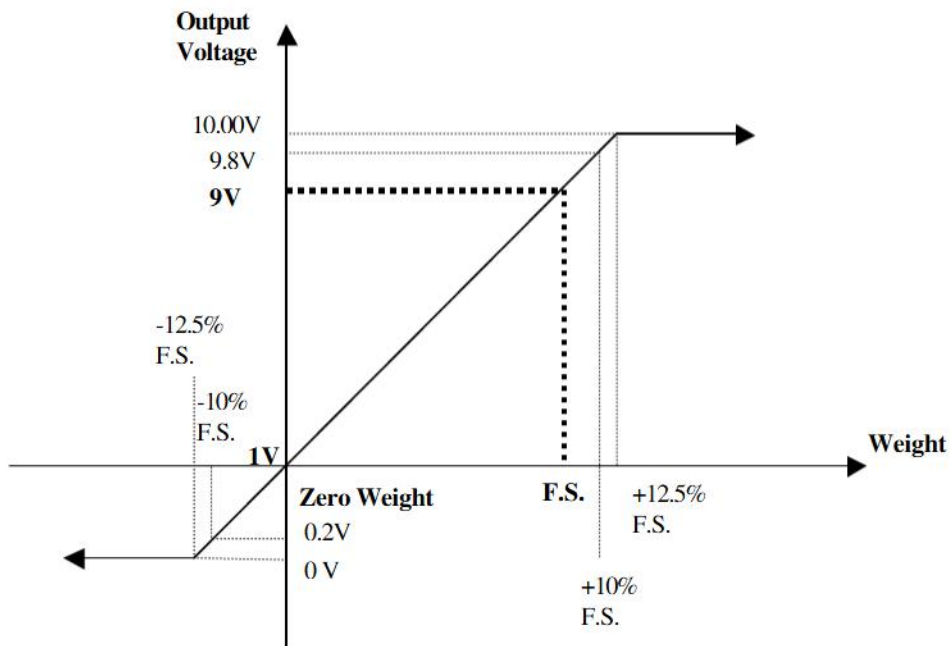

## 14.2 PIN CONFIGURATION

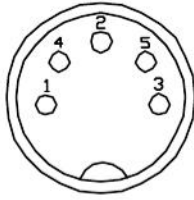

5 PIN DIN PLUG  
(BACK VIEW)

PIN	SIGNAL	REMARKS	PLUG WIRE COLOR
1	CO+	Current Output +	RED
2	CO-	Current Output – (GND)	YELLOW
3	VO+	Voltage Output +	BLUE
4	VO-	Voltage Output – (GND)	PURPLE
5	-	No Connection	

## 14.3 ANALOG INTERFACE BOARD SETUP

Replace blank bracket or RS232/485 I/F Board (TWB-02350) next to connector board (TWB-02310) with analog output I/F board (TWB-02370).

Set SPEC 58 is 1000 to enable Analog Output function, while set 0000 to disable it. Hardware jumper setting selects current or voltage mode, refer to silk screen on PCB. Only one output mode is available at the same time.

JP1	
1-2	VO
2-3	CO

JP3	JP4	VOUT
O	S	0-5V
S	O	0-10V

Remark: VO: Voltage Output  
CO: Current Output  
O: Open  
S: Short

#### 14.4 CALIBRATION PROCEDURE

Analog output value should be 4mA at Zero Point and 20mA at Capacity Weight. If the output values are not the appropriate value, adjust those by the following procedure.

ZERO – Rezeroing

SPAN1 – Fine adjustment

SPAN2 – Coarse adjustment

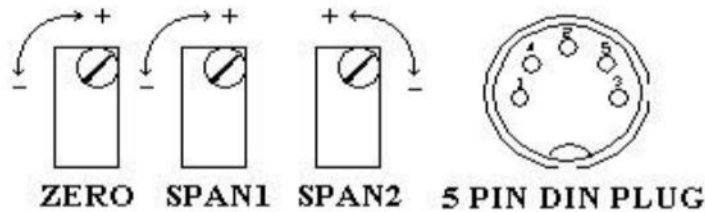

Before startup, precautions have to be taken to ensure all potentiometers are not overturned. After the check has been done, proceed with setup.

The procedure can be accomplished as follows:

##### STEP 1 – Zero offset adjust

Load all zeros, then tune the “ZERO”.

For the voltage mode, adjust to 1V, while for the current mode, on the other hand, adjust to 4mA.

##### STEP 2 – Coarse adjustment

Load all ones, adjust the “SPAN2” which constitutes the varying of the operating range. Careful tuning has to be taken, as it is very sensitive. It is termed as coarse adjustment because it varies a wider range. For the voltage mode, adjust to approximately 8.99V for the 0-10V range and approximately 4.2V for the 0-5V range. For the current mode, adjust to approximately 19.99mA.

##### STEP 3 – Fine adjustment

Adjust “SPAN1” which constitutes in fine adjustment to the actual full span. This has to be done after adjusting “SPAN2”.

This adjustment algorithm is iterative, therefore, STEP1 to STEP3 has to be repeated until convergence is obtained.

# DI-80 Limited Warranty

---

Rice Lake Weighing Systems (RLWS) warrants that all RLWS equipment and systems properly installed by a Distributor or Original Equipment Manufacturer (OEM) will operate per written specifications as confirmed by the Distributor/OEM and accepted by RLWS. All systems and components are warranted against defects in materials and workmanship for two (2) years.

RLWS warrants that the equipment sold hereunder will conform to the current written specifications authorized by RLWS. RLWS warrants the equipment against faulty workmanship and defective materials. If any equipment fails to conform to these warranties, RLWS will, at its option, repair or replace such goods returned within the warranty period subject to the following conditions:

- Upon discovery by Buyer of such nonconformity, RLWS will be given prompt written notice with a detailed explanation of the alleged deficiencies.
- Individual electronic components returned to RLWS for warranty purposes must be packaged to prevent electrostatic discharge (ESD) damage in shipment. Packaging requirements are listed in a publication, "Protecting Your Components From Static Damage in Shipment," available from RLWS Equipment Return Department.
- Examination of such equipment by RLWS confirms that the nonconformity actually exists, and was not caused by accident, misuse, neglect, alteration, improper installation, improper repair or improper testing; RLWS shall be the sole judge of all alleged non-conformities.
- Such equipment has not been modified, altered, or changed by any person other than RLWS or its duly authorized repair agents.
- RLWS will have a reasonable time to repair or replace the defective equipment. Buyer is responsible for shipping charges both ways.
- In no event will RLWS be responsible for travel time or on-location repairs, including assembly or disassembly of equipment, nor will RLWS be liable for the cost of any repairs made by others.

**THESE WARRANTIES EXCLUDE ALL OTHER WARRANTIES, EXPRESSED OR IMPLIED, INCLUDING WITHOUT LIMITATION WARRANTIES OF MERCHANTABILITY OR FITNESS FOR A PARTICULAR PURPOSE. NEITHER RLWS NOR DISTRIBUTOR WILL, IN ANY EVENT, BE LIABLE FOR INCIDENTAL OR CONSEQUENTIAL DAMAGES.**

**RLWS AND BUYER AGREE THAT RLWS'S SOLE AND EXCLUSIVE LIABILITY HEREUNDER IS LIMITED TO REPAIR OR REPLACEMENT OF SUCH GOODS. IN ACCEPTING THIS WARRANTY, THE BUYER WAIVES ANY AND ALL OTHER CLAIMS TO WARRANTY.**

**SHOULD THE SELLER BE OTHER THAN RLWS, THE BUYER AGREES TO LOOK ONLY TO THE SELLER FOR WARRANTY CLAIMS.**

No terms, conditions, understanding, or agreements purporting to modify the terms of this warranty shall have any legal effect unless made in writing and signed by a corporate officer of RLWS and the Buyer.

© 2002 Rice Lake Weighing Systems, Inc. Rice Lake, WI USA. All Rights Reserved.

**RICE LAKE WEIGHING SYSTEMS • 230 WEST COLEMAN STREET • RICE LAKE, WISCONSIN 54868 • USA**