

ManualsLib.com

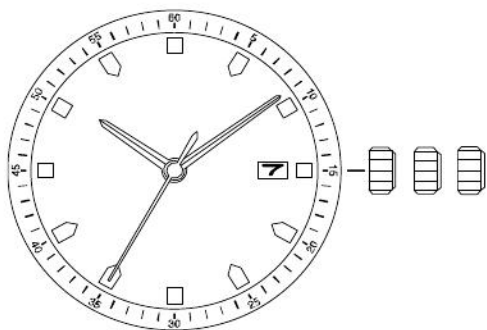

[ManualsLib.com](https://www.ManualsLib.com)

This drawing is provisional and subject to our reconfirmation and/or revision without notice.

DH3~DH4=22287 (±20)

Coordinates		
Point	X	Y
GM	0	0
DH3	-8759	6900
DH4	9251	-7500
b1	7996	7871
b2	6624	7608
b3	10699	5501
b4	10131	4822
b5	7803	-8063
b6	7535	-8688
b7	5416	-10145
b8	4736	-10171
b9	-7995	-7871
b10	-8624	-7608
b11	-10089	-5501
b12	-10131	-4822
b13	-7963	8063
b14	-7535	8688
b15	-5416	10145
b16	-4736	10171

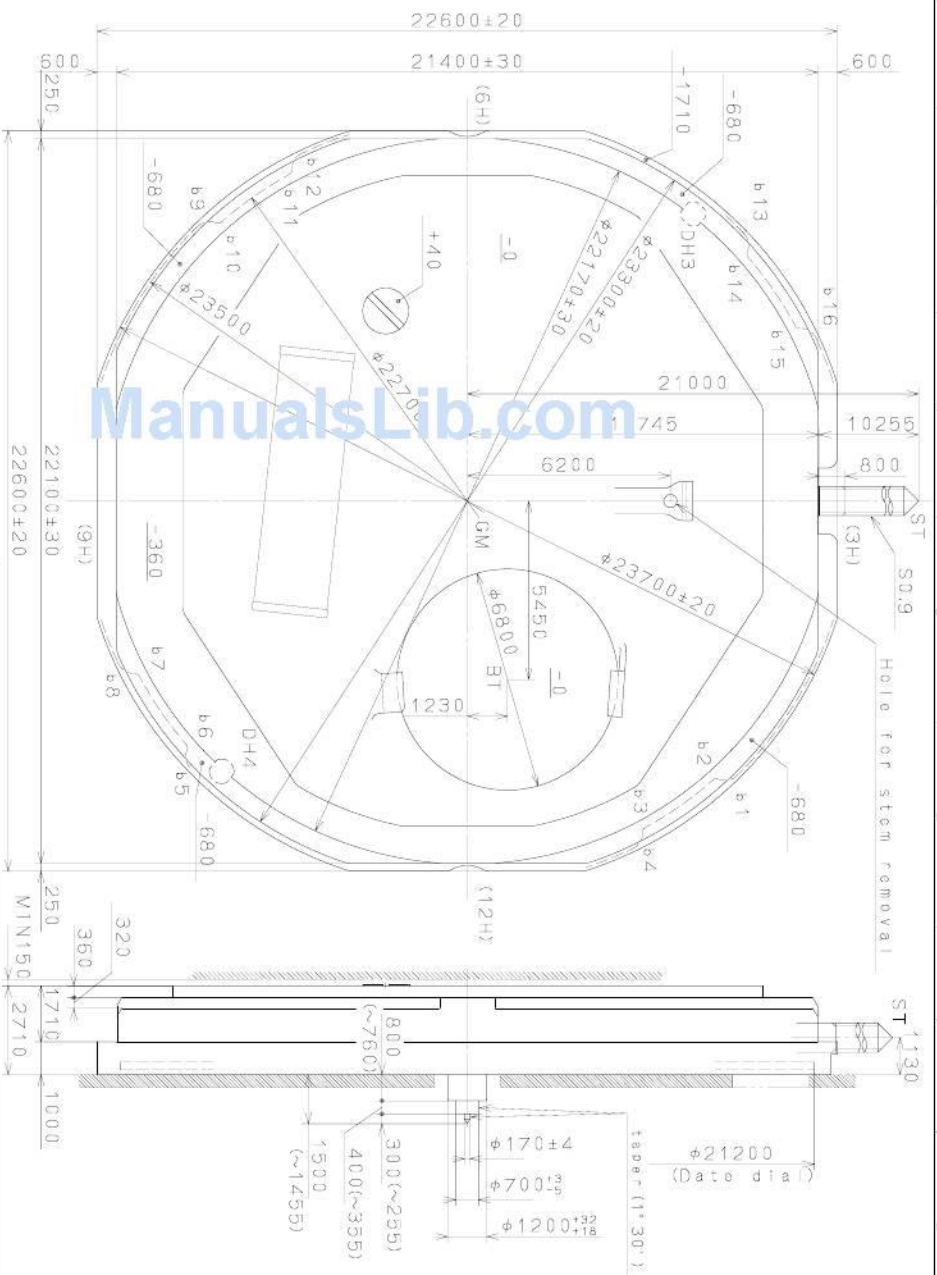

Section b1~b16

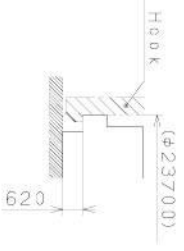

Quantity	1/108.0mm	Call No.: GW10
Unit	Scale	Parts No.:
Drawn	Date	Name
Checked	Date	Name
Approved	Date	Name
Material	Material	Frame for Case
Hardness	Surface Treatment	Drawing No.: GW10000
Plating	Notes	

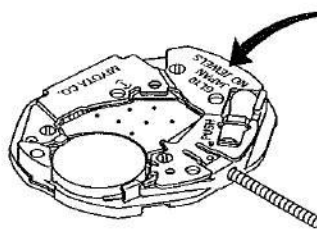
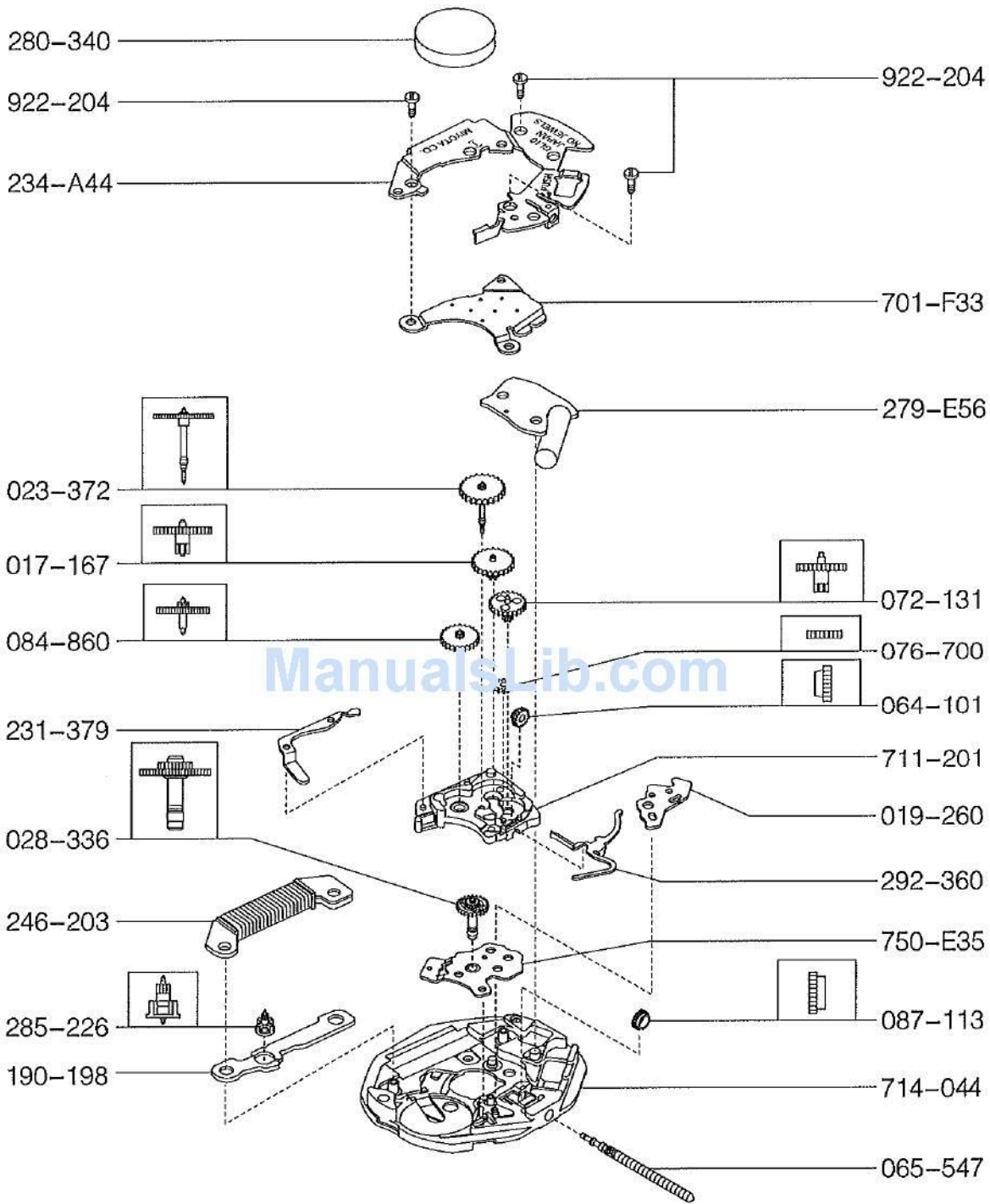

CALIBER NO.
NO. DE CALIBRE

Cal No.GL10-1/2

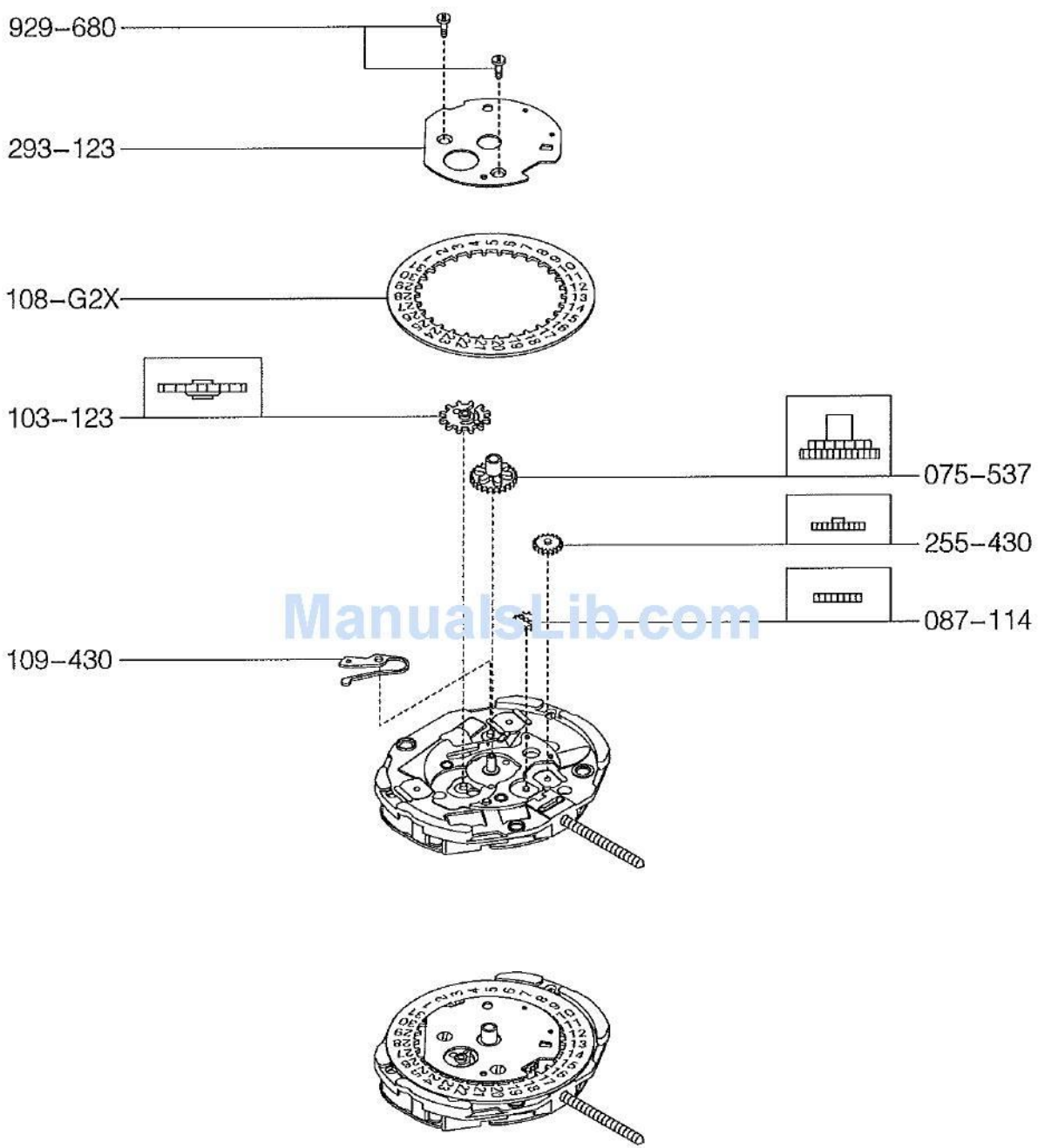

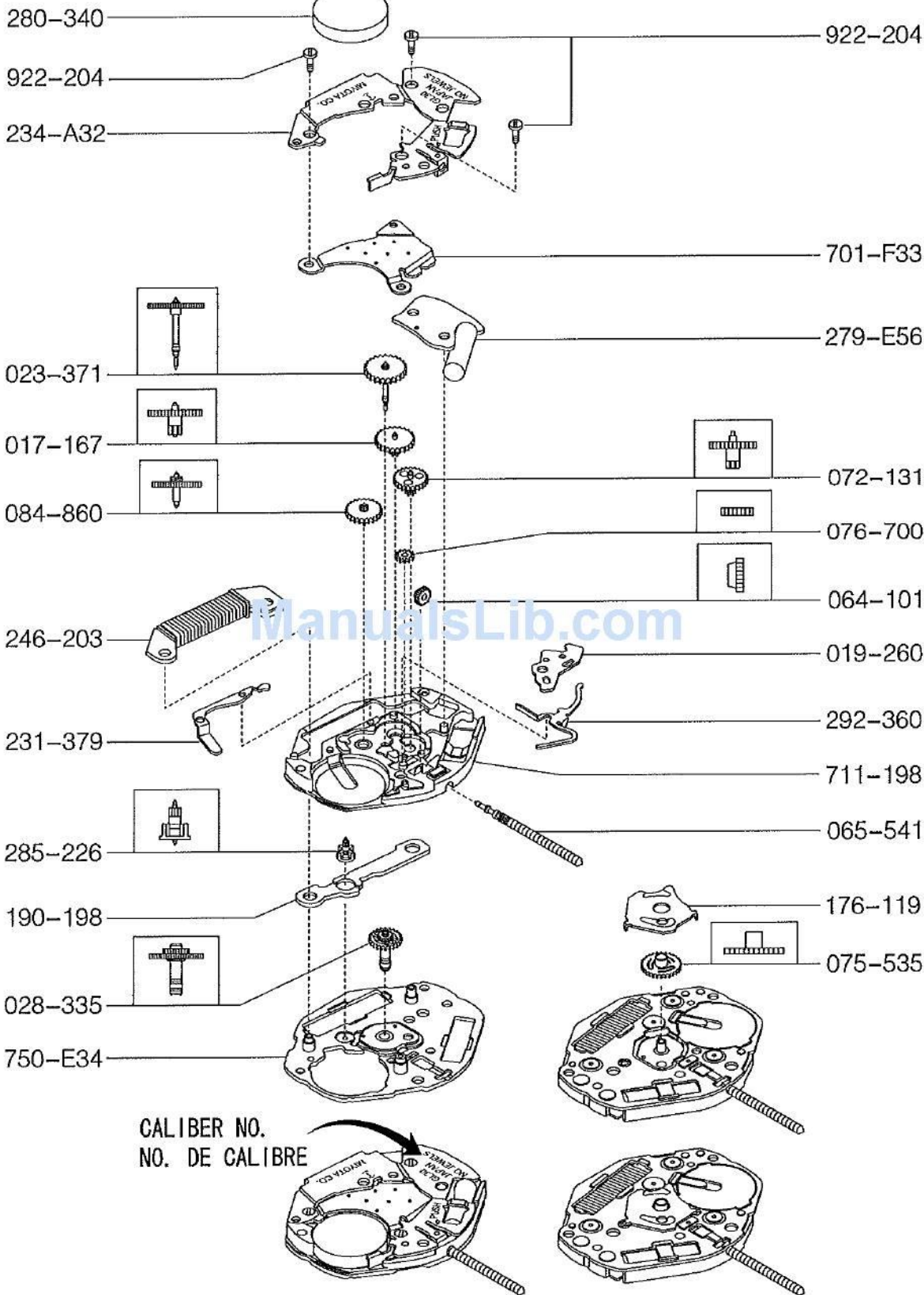

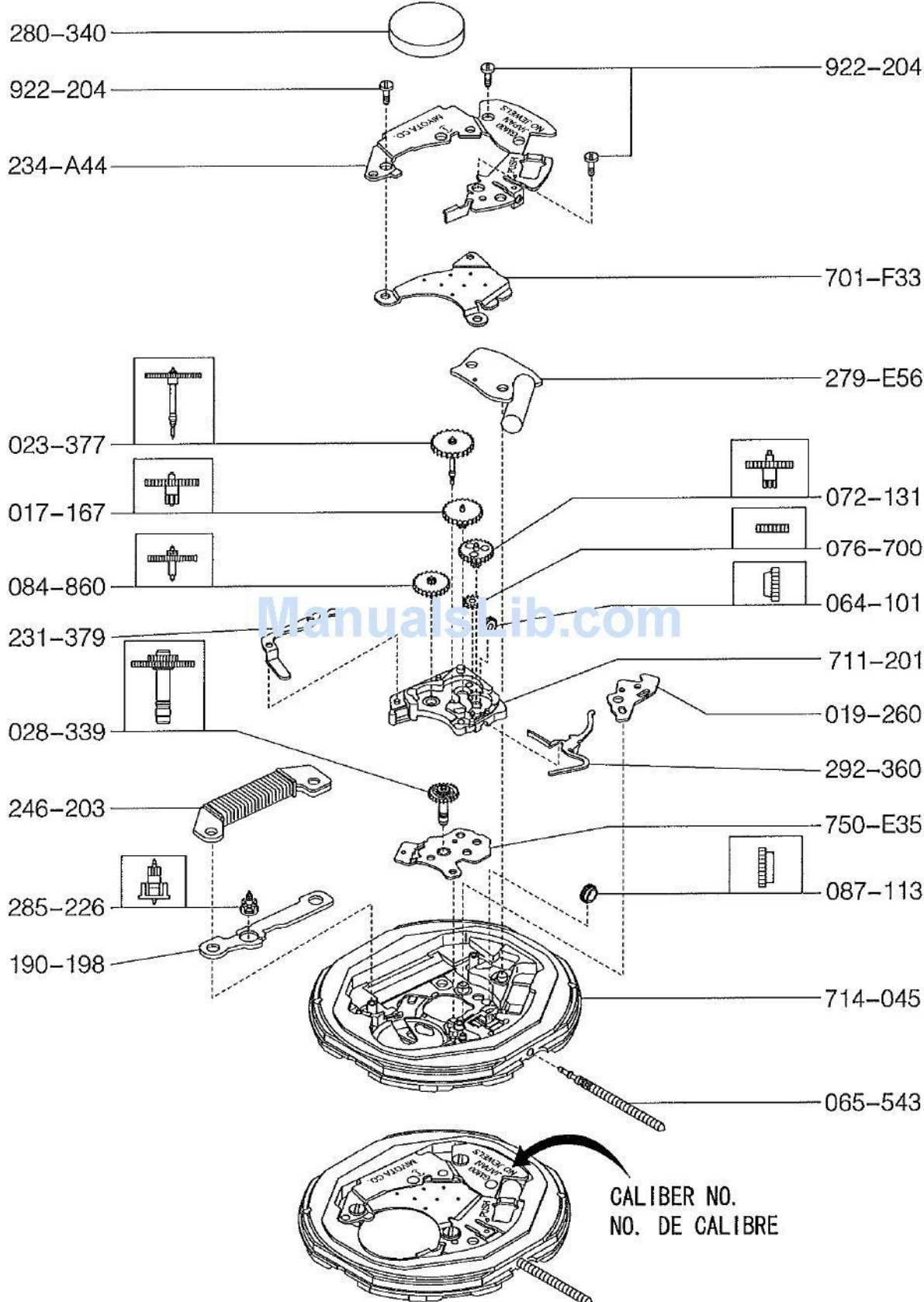

Cal No.GM00-1/2

178-140

308-A4X

929-680

293-127

108-F7X

103-125

109-430

075-543

255-430

116-123

ManualsLib.com

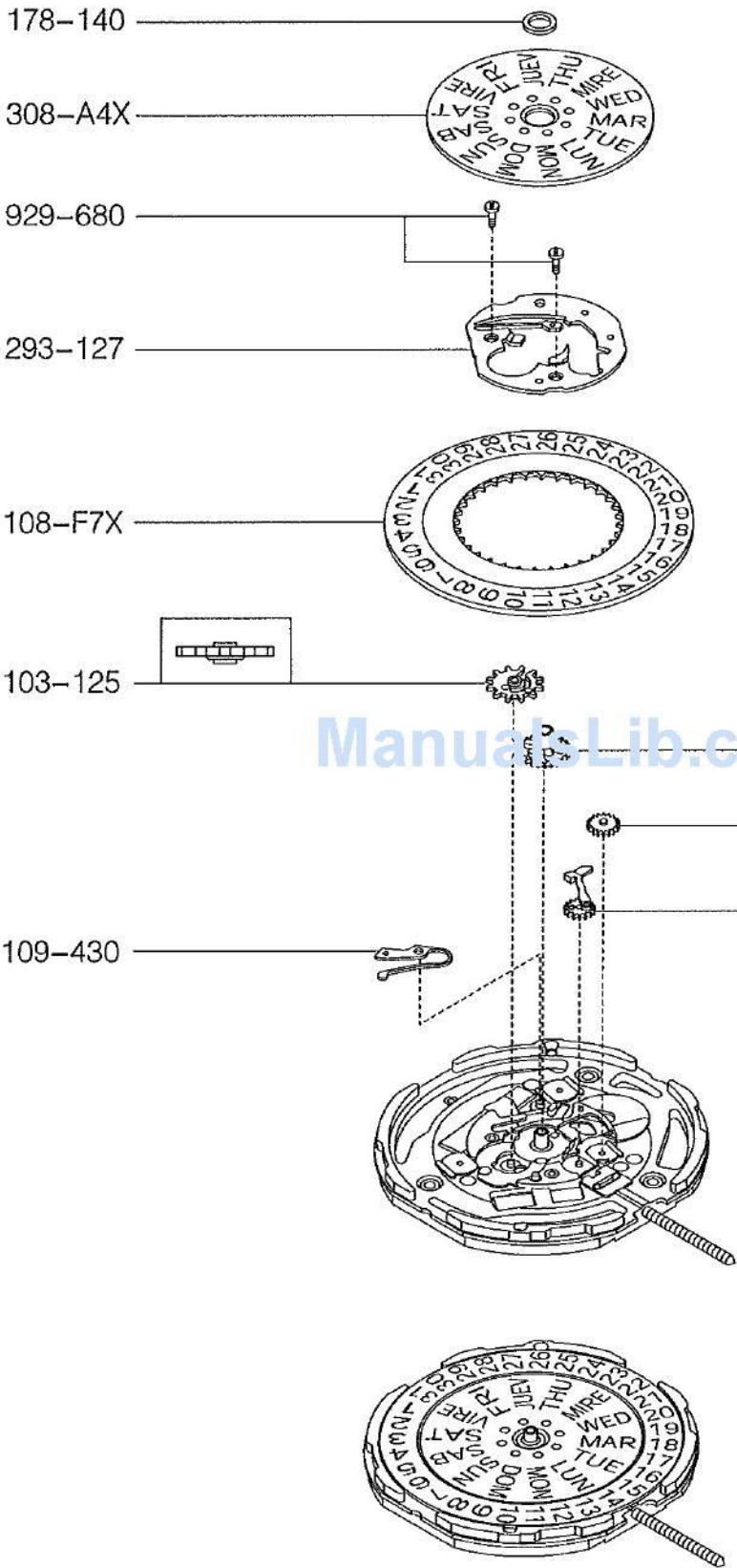

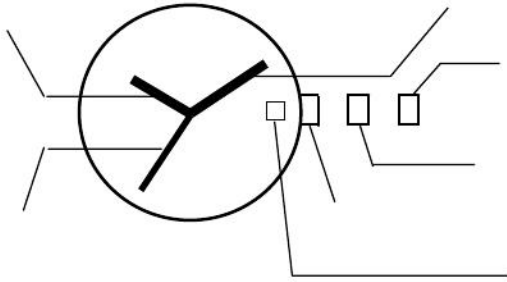

ManualsLib.com