

***TECHNICAL
INFORMATION***

CITIZEN QUARTZ

Cal.No.940※※

§1. OUTLINE

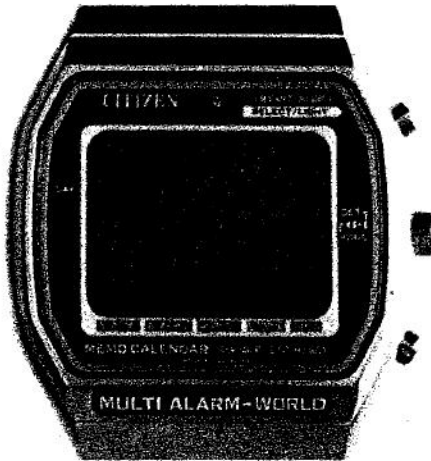

This is a digital quartz crystal watch for gentlemen with the liquid crystal display, featuring the multiple functions uniquely including the full 1-month calendar display plus the world-time function.

Furthermore, it includes the alarm (I), alarm (II), stopwatch, timer, illumination lamp, alarm monitor each. Every function of these can be operated in an easy and quick way via two switching mechanisms: the push-buttons and the crown.

§2. FEATURES

1) World-time function

The whole world is divided into 27 zones with 22 cities. The call-out of the time in the 27 cities plus the switching between the time of these cities and user's home time are possible. The name of each city is shown in three letters of the segments in the upper tier of the display part.

2) Full-calendar display

The "year" can be set in the cycle of 1901 ~ 2099 years, and the full 1-month calendar can be displayed during this period with operation of the crown.

With the calendar function of this watch, the date memorization is possible for five months to come. And the memorized date is shown through flashing of the "MEMO" mark in the mode of the normal time display. This unique calendar function is realized via the two-tier LC (liquid crystal) display panel developed by Citizen.

3) Correction system by crown

The digital display is corrected with turn of the crown: the right turn gives the count-up and the left turn the count-down respectively.

4) Power cell life indicator

The colon between the "hour" and "minute" display figures has no flashing usually but has the 2Hz-flashing (twice per second) when the life time of the power cell comes near to its end.

§3. SPECIFICATIONS

Caliber No.	9400-00A
Module	Outer dia.: 29.9mm ϕ (Maximum dia. 30.0mm ϕ) Thickness: 6.1mm (Power cell part 6.7mm)
Oscillation	32,768Hz
Accuracy	± 10 sec./month at normal temperatures (with temperature compensation)
Digital display part	<ul style="list-style-type: none"> ●Normal time display Hour, minute, second, AM/PM, date and day ●Calendar Month, full 1-month calendar, day and MEMO ●Alarm (I) display Hour, minute, AM/PM and alarm (I) mark ●Alarm (II) display Hour, minute, AM/PM and alarm (II) mark ●World-time display (in 27 zones/22 cities) Names of cities, hour, minute, second, AM/PM, day and world-time mark ●Stopwatch display (Timing possible up to 11H.59'59"99) Hour, minute, second, 1/100 sec. and stopwatch mark ●Timer display (Setting possible up to 11H.59'00") Hour, minute, second and timer mark
Integrated circuit	C/MOS-LSI (2 units)
Effective temperature range	$\pm 0^{\circ}\text{C} \sim +60^{\circ}\text{C}$ ($+32^{\circ}\text{F} \sim 140^{\circ}\text{F}$)
LC display panel	FE twist nematic liquid crystal
Additional functions	<ul style="list-style-type: none"> ●Illumination lamp ●Power cell life indicator ●Alarm monitor ●Fully automatic calendar (incl. leap years in 1901 ~ 2099 years)
Power cell (Silver oxide)	Parts No. : 280-15, WG-10 Nominal voltage : 1.55V (Ag ₂ O/K) Size : 11.6 ϕ x 3.1mm Capacity : 75mAH Life time : About 2 years (with 5-sec. lamp lighting and 60-sec. alarm ringing per day)

§ 4. HANDLING INSTRUCTIONS

1) External appearance

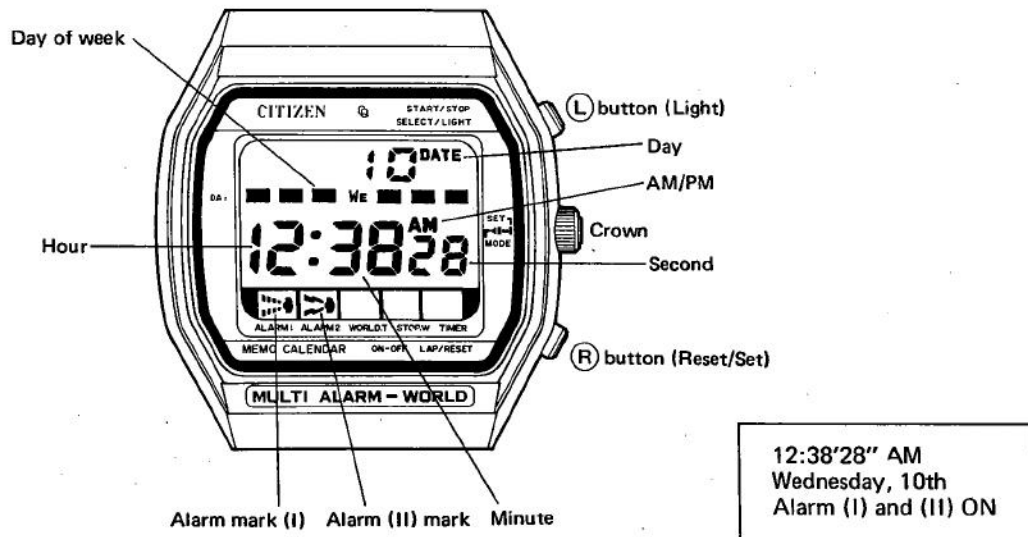

2) Method of operation

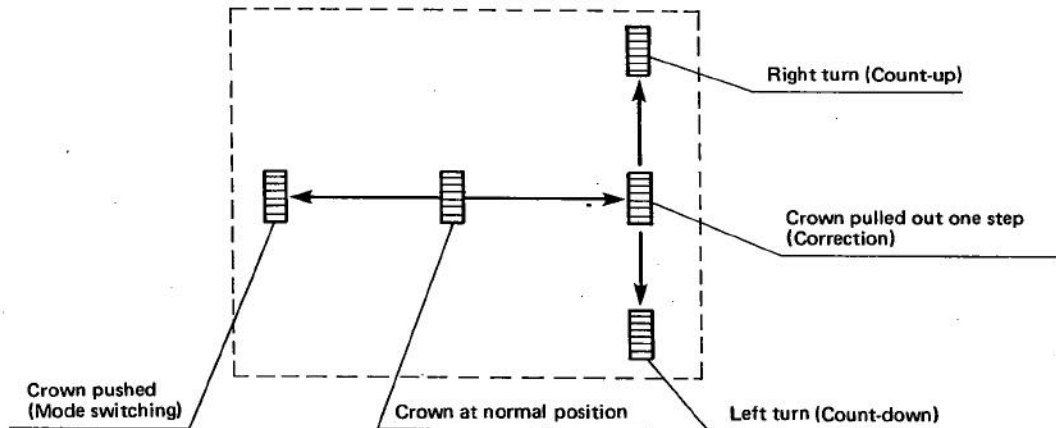

- ① The display mode switches as shown below with every push of the crown.
Normal time display → Full calendar display → Alarm (I) display → Alarm (II) display → World-time display → Stopwatch display → Timer display → Normal time display.
- ② With the crown pulled out by one step, the correcting state is secured for each mode (excluding the stopwatch display).
- ③ The (L) button is used for selection of the digit under each correction state as well as for lighting the illumination lamp (excluding the stopwatch function).
- ④ The (R) button features the different functions according to the display mode.
(Ex.) Normal time display: Checking for zones
Alarm (I) display: ON/OFF of alarm

3) Switching of modes (The flashing areas are shown in the red color.)

The display mode switches with every push of the crown.

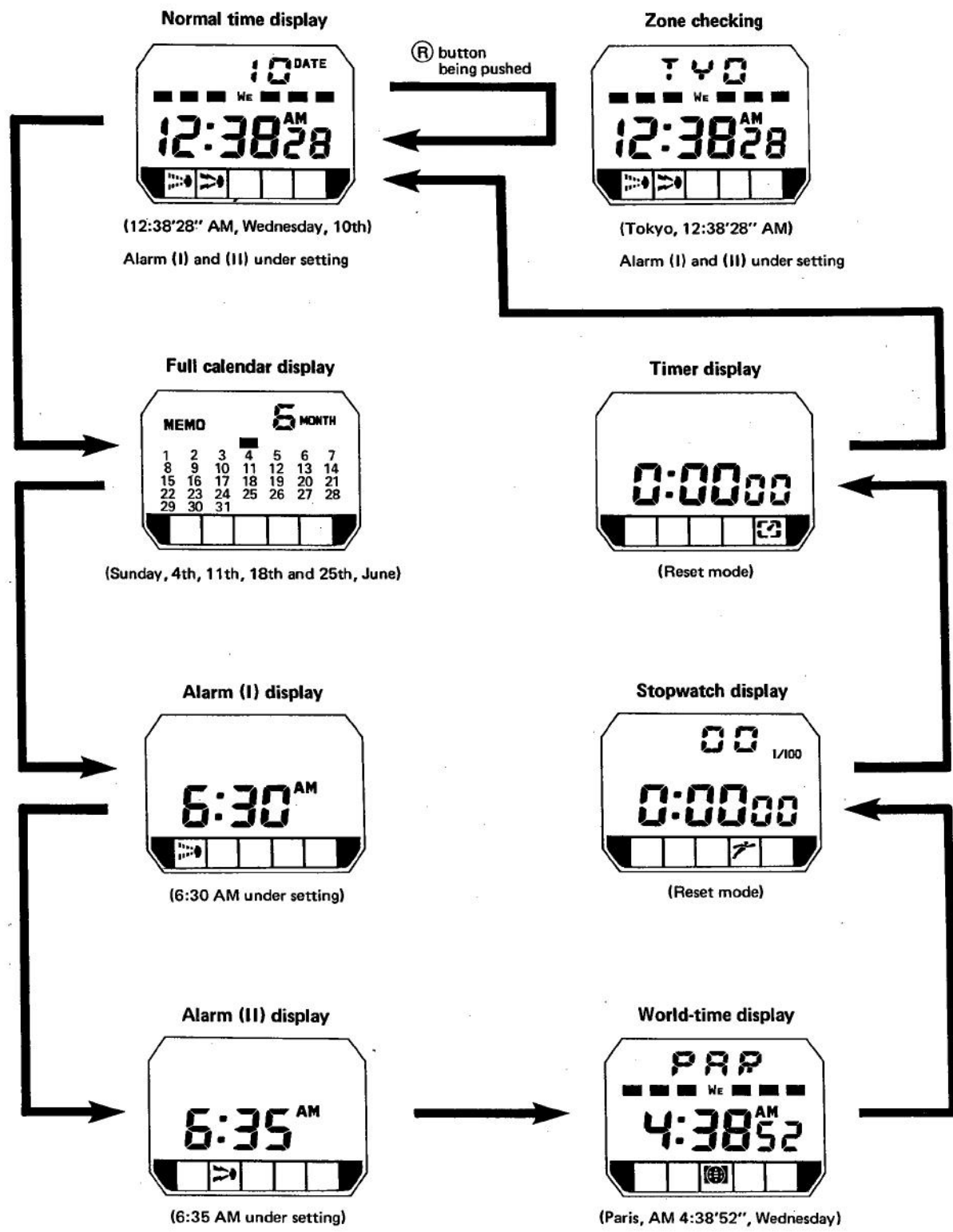

4) Setting of time

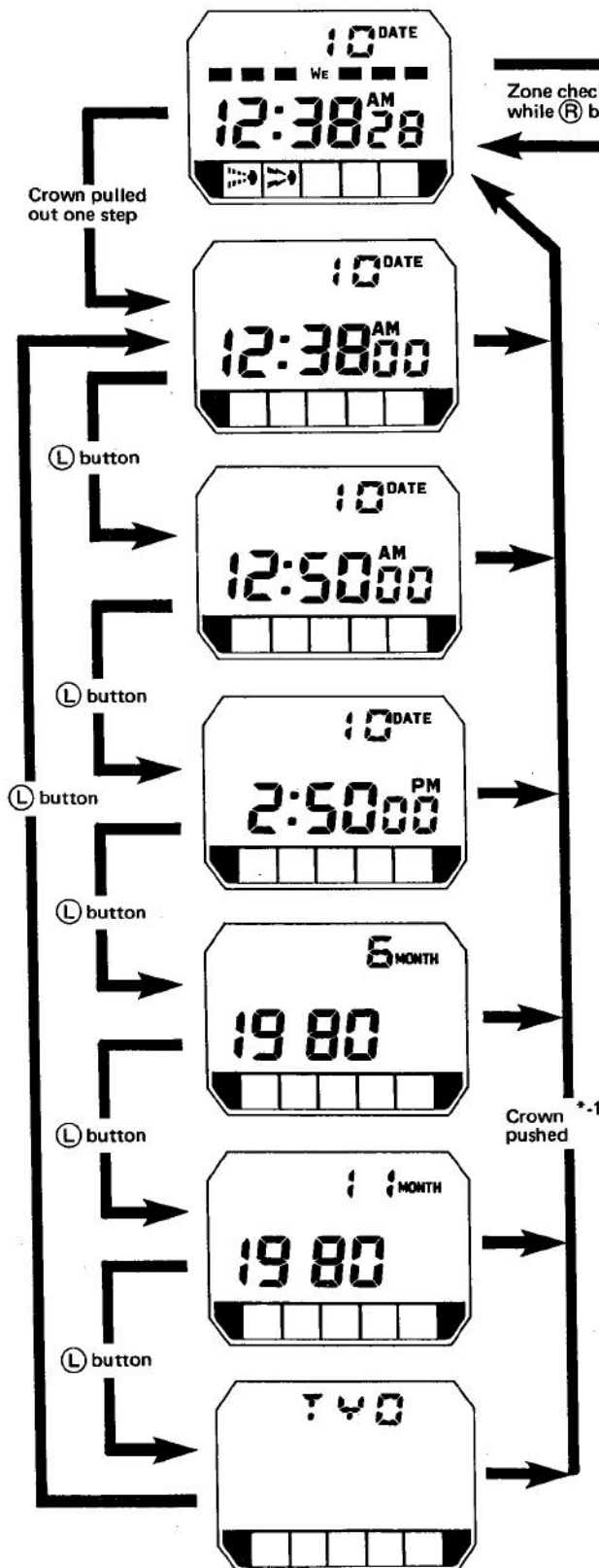

① 0-second reset and "minute" setting

When the crown is pulled out by one step in the mode of the normal time display, the "second" stays at "00" with the "minute" flashing.

(In that case, the "second" between "00" and "29" is cut down for waiting. While the "minute" is carried when the "second" reads 30 ~ 59.)

The "minute" is set by turning the crown.

- Right turn of crown: count-up
- Left turn of crown: count-down

② "Hour" setting

With push of L button in the setting mode of the "minute", both the "hour" and "AM/PM" have flashing.

The crown is turned to set the "hour" plus the "AM/PM". Never fail to make sure the AM or PM.

③ "Date" setting

With push of L button in the setting mode of "hour", the "date" has flashing. The crown is turned to set the "date".

④ "Month" setting

With push of L button in the setting mode of the "date", the display changes from "hour, minute, second and date" to "year and month" with the "month" flashing. The crown is turned to set the "month".

⑤ "Year" setting

With push of L button in the setting mode "month" the "year" (in A.D.) has flashing. The crown is turned to set the "year".

⑥ "Zone" setting

With push of L button in the setting mode of "year", the display of "year and month" disappears. And the name of the zone city is displayed with flashing in three alphabet letters and on the upper tier of the display part.

Then the crown is turned to set the time to the desired city (zone).

⑦ Return to normal time display

After setting the "zone" (city), the crown is pushed in to reset the normal time display with start of the "second" counting.

Note:

- (1) The "days" of the week requires no setting because they are set automatically with setting of "year, month and date".
- (2) The stopwatch or timer function under operation can be continued although the crown is pulled out by one step with the "second" showing "00".
- (3) If the non-existing date is set in the display of "year, month and date", the error mark "ERR" is displayed instead of the mark "DATE" when the normal time display is reset. In such case, the setting must be given again in the correct way.

***-1 (Crown pushed)**

Whenever the crown is returned to its normal position from the 1-step-pulled position in any setting mode, the "second" starts counting to reset the normal time display.

5) Full calendar display and memory date setting

With one push of the crown in the mode of the normal time display, the full calendar display is secured for the "month, day mark and 1-month calendar".

In that case, the "month and day" which was set in the preceding setting is displayed with the "date" set flashing.

The display of the "year and month" is continued while (R) button is pushed in the mode of the full calendar display.

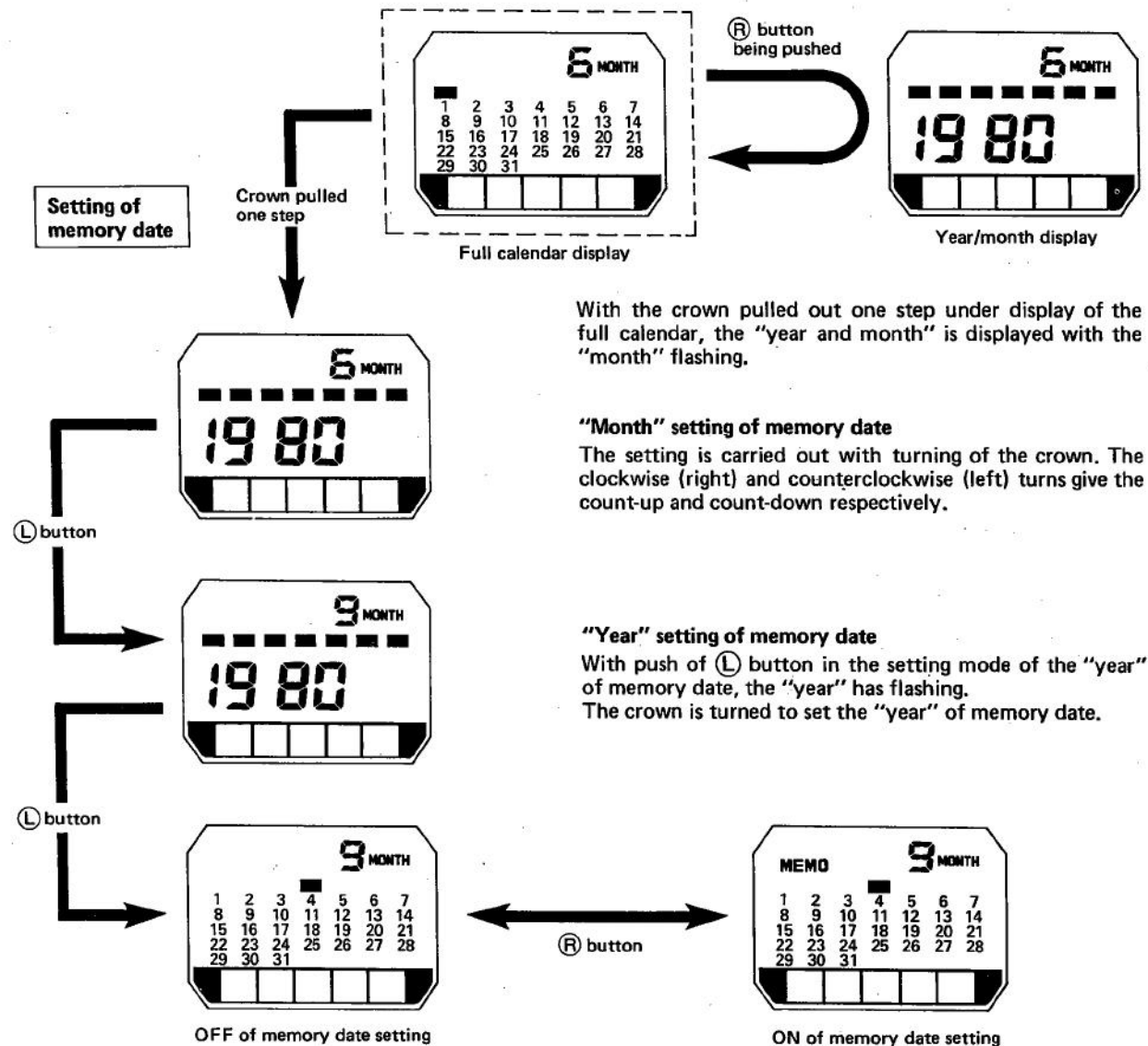

"Date" setting of memory date

With push of (L) button in the setting of the "year" of memory date, the full calendar (equivalent of full one month) is displayed with the first day flashing. Then the crown is turned to call out the date the user wants to memorize.

Then mark "MEMO" glows at the upper left of the display part with push of (R) button to indicate the date to be memorized in the year and month. And with the second push of (R) button, the mark "MEMO" disappears for cancel.

(Ex.)

It is June 10th, 1980 today, and memorization is wanted to September 18th, 1980 for the birthday of someone.

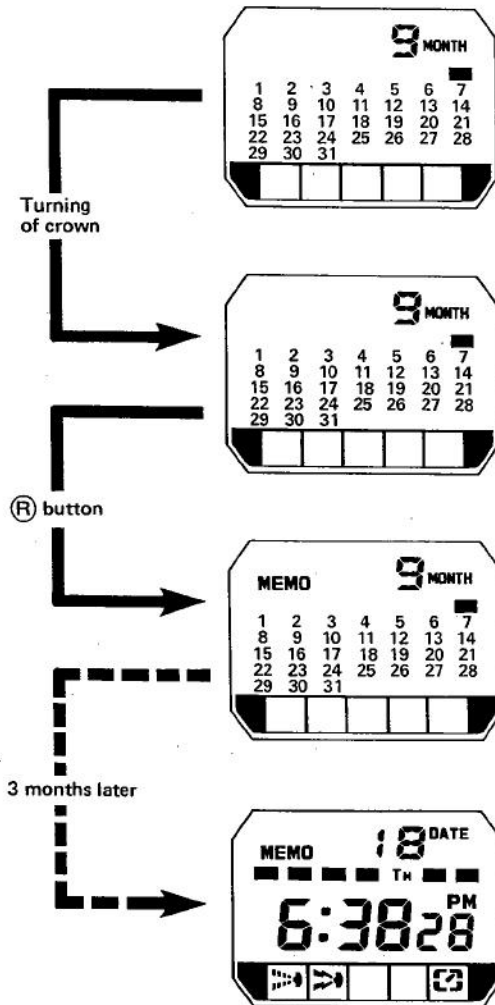

With push of (L) button after setting the memory date of the "year", the first day of the month has flashing.

At the moment of flashing of the first date, the crown is turned. Thus the flashing shifts to the first → second → third day and so on. And the turning of the crown is stopped at the moment when the 18th date has flashing.

Under these state, the (R) button is pushed. And thus mark "MEMO" glows at the upper left of the display part.

On September 18th, "MEMO" flashes to indicate that today is memorized date. (The mode of normal time display)

The memorization for the date is possible up to five months to come (for six months in all). If the date is set outside this memorizable period, no flashing is given to the first date of the month and with no reaction secured even with turning of the crown.

6) Function of alarm (I)

With a push of the crown in the calendar display mode, the display of alarm (I) is secured. The ON and OFF of alarm setting is switched alternately with every puch of (R) button (in the setting mode of "minute" or "hour").

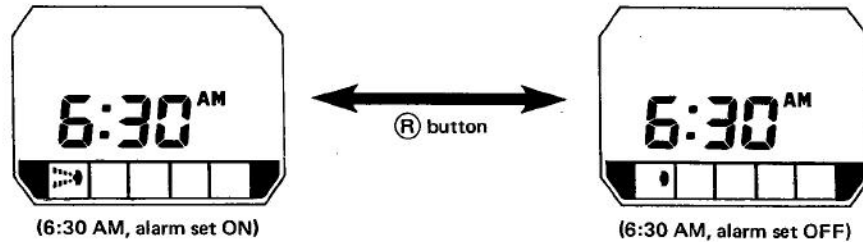

•Setting of alarm time

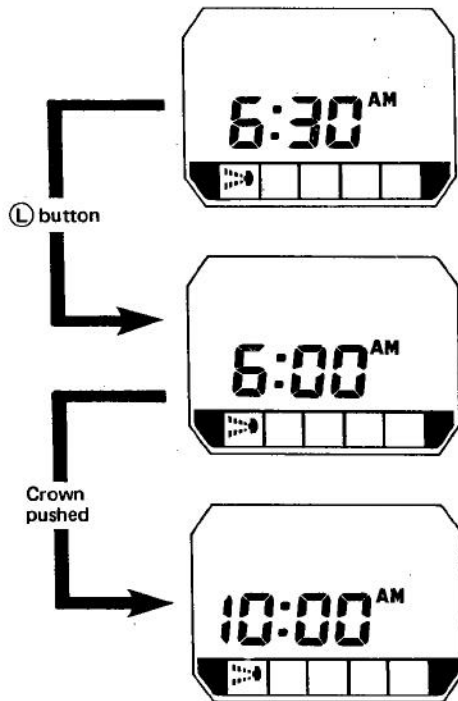

Setting of alarm "minute"

In the mode of "alarm (I) time display (full calendar), the crown is pulled out one step after once pushed. Thus the alarm "minute" has flashing. Then the crown is turned to set the alarm "minute".

- Clockwise turn: count-up
- Counterclockwise turn: count-down

Setting of alarm "hour"

With push of (L) button in the setting mode of the alarm "minute", the alarm "hour" plus "AM/PM" have flashing. Then the alarm "hour" is set by making sure the AM or the PM.

Display of alarm (I) time

When the setting is over for the alarm "hour", the crown must be pushed in one setp.

•Ring of alarm (I)

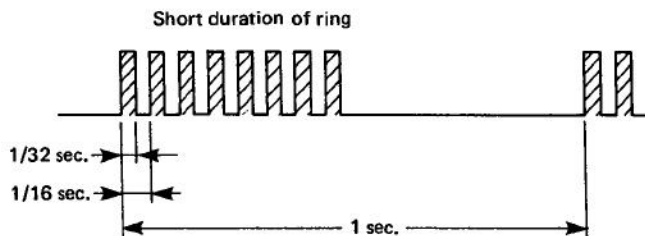

The alarm ring can be stopped by pushing the (L) button, the (R) button or the crown.

At the set time of alarm (I), the alarm rings in the short duration as shown in the above diagram in 8 times per second and for one minute.

7) Function of alarm (II)

The display of alarm (II) is secured with a push of the crown in the mode of the alarm (I) display. The operation of alarm (II) is identical to alarm (I) but with the different way of ringing.

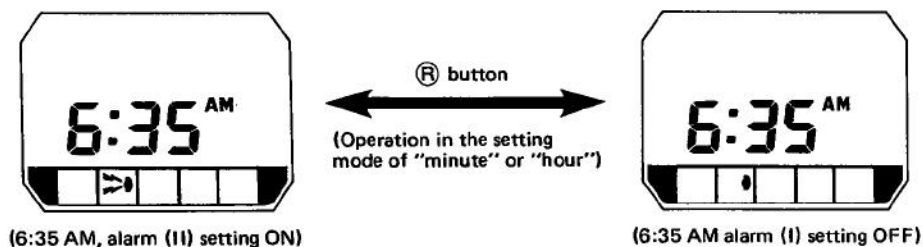

The ON and OFF of the alarm (II) setting are switched alternately with every push of **R** button. And the marks "➤" and "•" are displayed with flashing at the alarm (II) setting ON and OFF respectively. In the mode of the normal time display, the mark "➤" is displayed at the alarm (II) setting ON to indicate that the alarm (II) is now under setting.

•Setting of alarm time

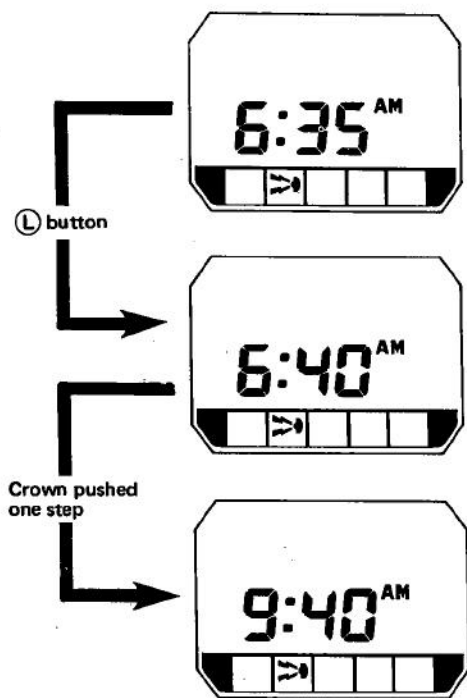

Setting of alarm "minute"

With the crown pulled out one step in the mode of "alarm (II) time display", the alarm "minute" has flashing. Then the crown is turned to set the alarm "minute".

- Clockwise turn: count-up
- Counterclockwise turn: count-down

Setting of alarm "hour"

With push of **L** button in the setting mode of the alarm "minute", the alarm "hour" plus "AM/PM" have flashing. The alarm "hour" is set by making sure the AM or the PM.

Display of alarm (II) time

The crown is pushed in by one step when the setting is over for the alarm "hour".

•Ring of alarm (II)

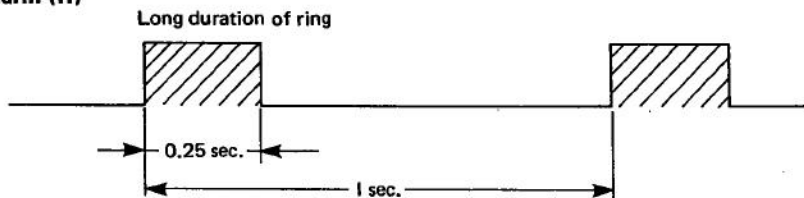

As shown above, the alarm rings in the long duration every second and for one minute at the set time of alarm (II). The alarm ring can be stopped by pushing the **L** button, the **R** button or the crown.

8) World-time function

The world-time display is secured with a push of the crown under the display of the alarm (II). In this case, the called-out city (zone) is given the time of the city (zone) which was called out finally in the previous time.

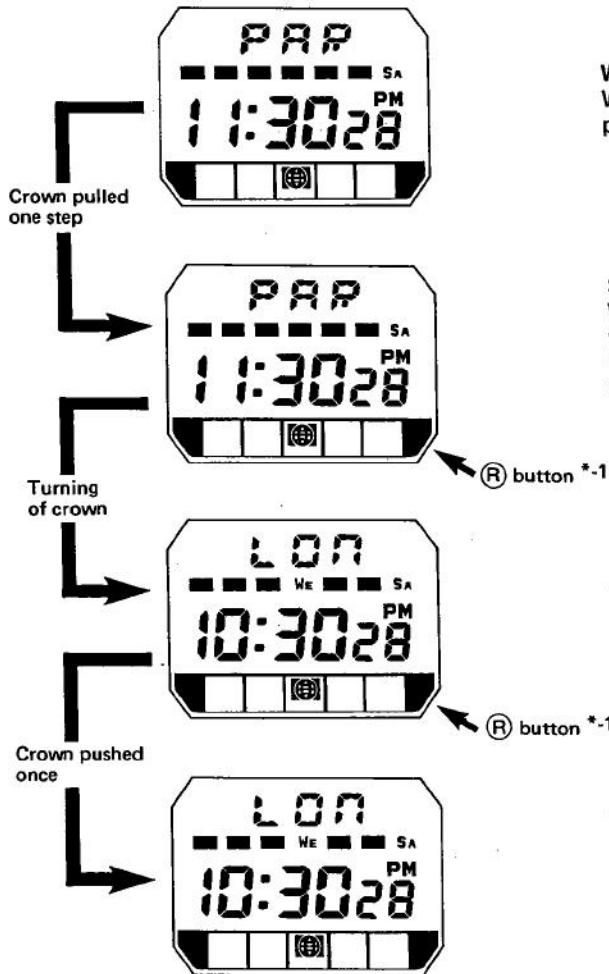

World-time display

With a push of the crown in the mode of the alarm (II) display, the world-time display is given.

Selection mode of world-time "city (zone)"

With the crown pulled out one step in the mode of the world-time display, the selection mode is obtained for the "city (zone)". And thus the "city (zone)" has flashing on the upper tier of the display part.

Selection of world-time "city (zone)"

With turning of the crown, the display of the time also changes along with the "city (zone)".

World-time display

With a push of the crown after calling out the desired "city (zone)", the flashing of the "city (zone)" stops. And the time of that moment is displayed in the next world-time display.

•Switching of home time

(*-1) With push of (R) button in the selection mode of the world-time "city (zone)", the switching is given between the preceding "city (zone)" and that which was set (or is being set) in the setting mode of the "normal time". And with the second push of (R) button, the display is returned to the "city (zone)" which was set at first.

With switching of the home time, the time of alarms (I) and (II) interlock the switched time display.

(Ex.)

Home time: Paris
Alarm (I) set at 6:00 AM

Home time: London
Ring at 6:00 AM

Display letters or symbols	Time differential	Cities
---	-11	
HNL	-10	Honolulu (USA)
---	-9	
LA4	-8	Los Angeles (USA)
DEN	-7	Denver (USA)
CHI	-6	Chicago (USA)
NYC	-5	New York (USA)
CCS	-4	Caracas (Venezuela)
SAO	-3	São Paulo (Brazil)
---	-2	
---	-1	
LON	±0	London (England)
PAR	+1	Paris (France)
CAI	+2	Cairo (Egypt)

Display letters or symbols	Time differential	Cities
MOW	+3	Moscow (USSR)
THP	+4	Teheran (Iran)
KHI	+5	Karachi (Pakistan)
DEL	+5.5	Delhi (India)
DAC	+6	Dacca (Bangladesh)
RGN	+6.5	Rangoon (Burma)
BKK	+7	Bangkok (Thailand)
SIN	+7.5	Singapore
HKG	+8	Hong Kong
TYO	+9	Tokyo (Japan)
SYD	+10	Australia (Sydney)
---	+11	
WLG	+12	Wellington (New Zealand)

The world-time function displays the time of 22 cities in 27 zones in the world. The cities shown in the upper tier of the display part are the key cities of each zone which are shown in the international city codes as listed below.

HNL: Honolulu	Includes the Hawaii and Anchorage regions.
LAX: Los Angeles	The standard time of USA at the Pacific Ocean area.
DEN: Denver	The standard time of USA at the mountain area.
CHI: Chicago	The standard time of USA at the middle area.
NYC: New York	The standard time of USA at the eastern area.
CCS: Caracas	The capital of Venezuela.
SAO: São Paulo	A city in Brazil and identical to Rio de Janeiro.
LON: London	The international standard time set by the meridian line of zero-long. Passing the Greenwich Royal Observatory in London, England.
PAR: Paris	The capital of France and covers most major cities in Europe such as Rome, etc. (excl. England)
CAI: Cairo	The capital of Egypt.
MOS: Moscow	The capital of USSR.
THR: Teheran	The capital of India and also includes Dubai in the United Arab Emirates.
KHI: Karachi	A city of Pakistan.
DEL: Delhi	The capital of India.
DAC: Dacca	The capital of Bangladesh
BKK: Bangkok	The capital of Thailand and also includes Jakarta of Indonesia.
RGN: Rangoon	The capital of Burma.
SIN: Singapore	Located at the tip of Malay Pen.
HKG: Hong Kong	Peking of China is included in this zone.
TYO: Tokyo	The time in Tokyo is earlier by 9 hours than the international standard time. And Seoul is included in this area.
SYD: Sydney	A port city in Australia, featuring about 1H-time differential with a far distance in terms of the latitude from Tokyo zone.
WLG: Wellington	The capital of New Zealand.

9) Stopwatch function

The display of the stopwatch is obtained with a push of the crown in the mode of the world-time display.

The display features one of the five modes shown below, and the timing is based on the "reset" mode.

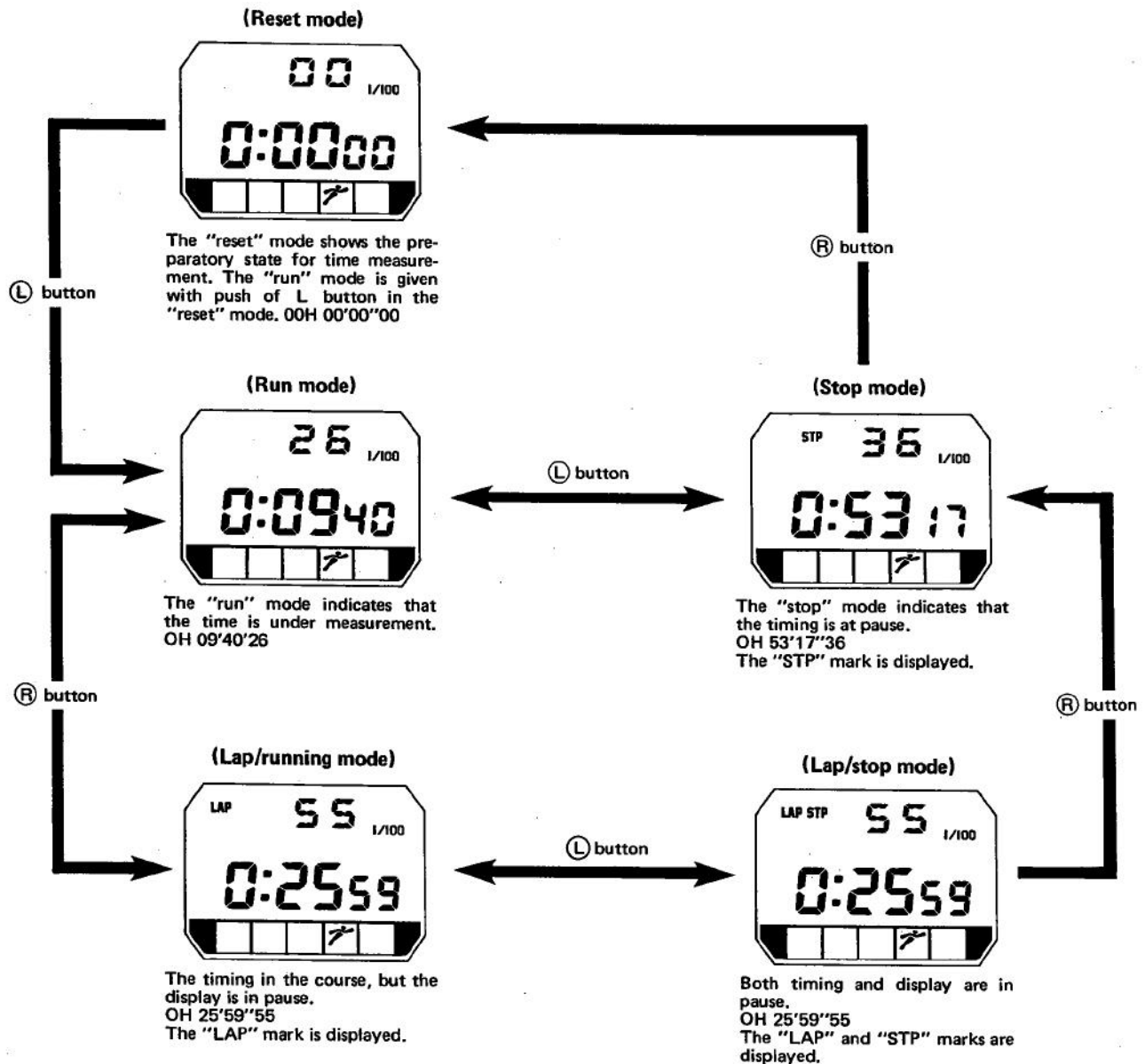

- (1) The mark "7" glows to indicate that the stopwatch function is now under operation in case the normal time display is given in use of the stopwatch ("run" and "lap/running" modes).
- (2) With the soft push of L button, the lamp does not glow. The lamp, however, glows if the L button is pushed strong.
- (3) With this watch, the alarm confirmation tone is not produced although the L button is pushed.

10) Timer function

The timer display is given with a push of the crown in the mode of the stopwatch display.

•Setting of timer time

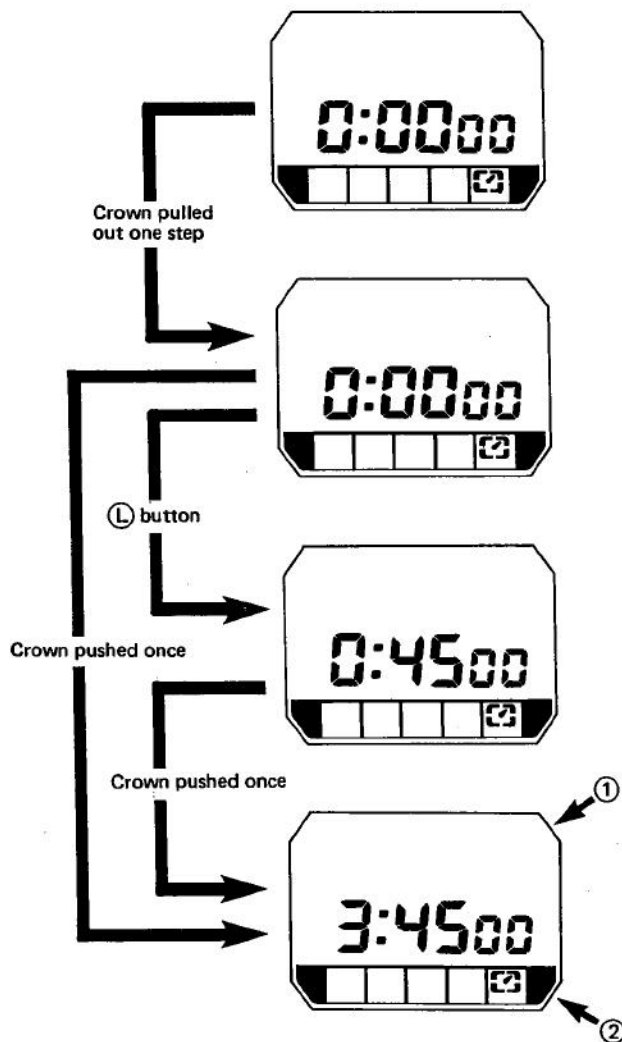

Timer display

With a push of the crown under the display of stopwatch, the timer display is secured.

Setting of timer "minute"

With pull-out of the crown by one step in the mode of the timer display, the timer "minute" has flashing. Then the crown is turned to set the timer "minute".

- Clockwise turn: count-up
- Counterclockwise turn: count-down

Setting of timer "hour"

With push of (L) button after the setting is over with the timer "minute", the timer "hour" has flashing. Then the crown is turned to set the timer "hour".

Preparatory state for timer operation

The crown is pushed once after the setting is over with the timer "hour". Thus the flashing of the timer "hour" ceases, and the preparatory state is secured for the timer operation.

- ① The timer starts with push of (L) button and then stops temporarily with the second push of (L) button.
- ② With push of (R) button under operation of the timer, the time set precedingly is displayed regardless of the part-way time, and then the timer function starts again.

- (1) The alarm rings at the time set by the timer. The alarm ring is same as that of the alarm (I): the short duration of ring is given 8 times in one second and for 1 ~ 2 minutes.
- (2) The ringing of the alarm can be stopped with push of either one of the crown, (L) button or (R) button.
- (3) When the normal time display is reset under operation of the timer, the mark "Ⓜ" is displayed to indicate that the timer is now under operation.
- (4) The simultaneous use is impossible between the stopwatch function and the timer function.
- (5) With a push of the crown in the mode of the timer display, the display is reset to the normal time.

11) Alarm monitor function

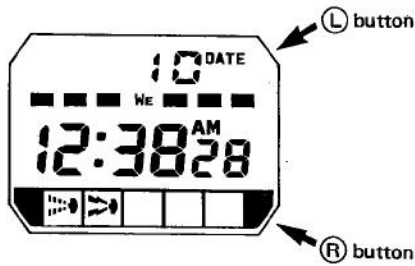

With simultaneous push of both (L) and (R) buttons under the normal time display, the alarm confirmation tone can be heard. This confirmation tone is identical to the alarm (I) ring.

*This caliber uses the double-layer LC display panel for the first time in Citizen.

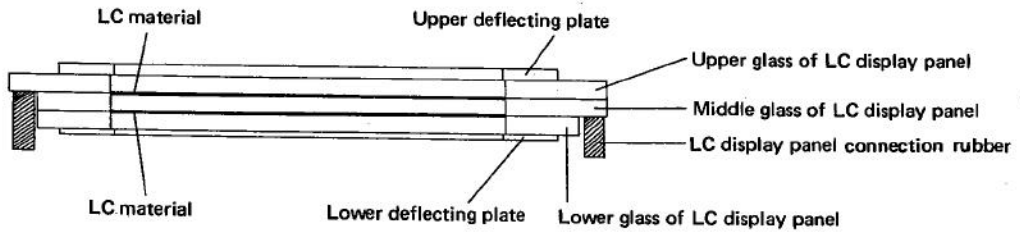

*Correction by clockwise/counterclockwise turn of crown

With turn of the crown, the switch gear intermeshing the square part of the setting stem is turned. This switch gear has projections at four areas to secure the contact to the pattern of the plate complete for the switching action. Therefore, four corrections are possible with a turn of the the crown.

*Notes on power cell replacement

The non-existing display^{*-1} may rarely be given when the power cell is replaced. In that case, the "all reset" must be given and then the time can be set normally.

The "all reset" can be given by turning the crown along with (L) and (R) buttons pushed at one time plus the crown pulled out one step.

*-1 Non-existing display

The non-existing display means the display that could not possibly occur. For instance, the normal form of "8" may rarely be displayed in such non-existing form of "H". This is due to the fact that some parts of the segments of the normal display form have no glowing at all.