



MTP SERIES
THERMAL PRINTER MECHANISM
TECHNICAL REFERENCE

U00084438003

Seiko Instruments Inc.

MTP SERIES THERMAL PRINTER MECHANISM TECHNICAL REFERENCE

Document Number U00084438003

| | |
|----------------|----------------|
| First Edition | January 1995 |
| Second Edition | September 2003 |
| Third Edition | December 2005 |
| Fourth Edition | April 2011 |

Copyright © 1995, 2003, 2005, 2011 by Seiko Instruments Inc.
All rights reserved.

Seiko Instruments Inc. (hereinafter referred to as "SII") has prepared this technical reference for use by SII personnel, licensees, and customers. The information contained herein is the property of SII and shall not be reproduced in whole or in part without the prior written approval of SII.

SII reserves the right to make changes without notice to the specifications and materials contained herein and shall not be responsible for any damages (including consequential) caused by reliance on the materials presented, including but not limited to typographical, arithmetic, or listing errors.

SII ● is a trademark of Seiko Instruments Inc.

PREFACE

This reference manual describes the specifications and basic operating procedures for the MTP Series Thermal Printer Mechanisms. Read it thoroughly so that you are able to use the MTP Series Thermal Printer Mechanisms properly.

The MTP (RoHS supporting) series has the following eight types of printers.

- MTP102-13B-E
- MTP102-16B-E
- MTP201-20B-E
- MTP201-24B-E
- MTP201-G128-E
- MTP201-G166-E
- MTP401-40B-E
- MTP401-G280-E

In this reference manual, the information mentioned as MTP is common to all models unless otherwise noted, and if the information is different depending on the model, specific model name is mentioned clearly.

Fully investigate the intellectual proprietary rights of the sample circuits designed in this manual before using.

The printer complies with EU RoHS Directive (2002/95/EC).
The printer contains "Pb", the details are described below.

- a particular free-cutting steel parts, a particular component in glass of the electronic parts

*Lead-containing items listed above are exempt from RoHS (2002/95/EC).

TABLE OF CONTENTS

| Section | Page |
|--|------|
| CHAPTER 1 FEATURES | |
| CHAPTER 2 SPECIFICATIONS | |
| 2.1 PART NUMBER..... | 2-1 |
| 2.2 GENERAL SPECIFICATIONS..... | 2-2 |
| 2.2.1 Character Printers..... | 2-2 |
| 2.2.2 Graphic Printers..... | 2-4 |
| 2.3 MOTOR DRIVER CHARACTERISTICS..... | 2-6 |
| 2.4 TG (TACHO-GENERATOR) OUTPUT CHARACTERISTICS..... | 2-8 |
| 2.5 HOME SWITCH..... | 2-9 |
| 2.6 THERMAL PRINT HEAD..... | 2-10 |
| 2.6.1 Head Specifications..... | 2-10 |
| 2.6.2 Head Applied Energy Correction..... | 2-11 |
| 2.6.3 Head Activation Pulse Width..... | 2-12 |
| 2.6.4 Control of Printing Pulse Width..... | 2-13 |
| 2.6.5 Initialization..... | 2-14 |
| 2.6.6 Paper Feeding..... | 2-14 |
| CHAPTER 3 TERMINAL ASSIGNMENT | |
| 3.1 B HEAD-MOUNTED PRINTER..... | 3-1 |
| 3.1.1 Thermal Head Control Terminal..... | 3-1 |
| 3.1.2 Motor and Switch Control Terminal..... | 3-2 |
| 3.2 G HEAD-MOUNTED PRINTER..... | 3-3 |
| 3.2.1 Thermal Head Control Terminal..... | 3-3 |
| 3.2.2 Motor and Switch Control Terminal..... | 3-3 |

Section

Page

**CHAPTER 4
TIMING CHART**

| | | |
|-------|---|-----|
| 4.1 | TIMING CHART | 4-1 |
| 4.2 | DETAILED CHART OF PRINTING START TIMING | 4-3 |
| 4.3 | CONTINUOUS PRINTING OPERATION | 4-3 |
| 4.3.1 | Home Switch Signal Method | 4-3 |
| 4.3.2 | Timing Signal Count Method | 4-4 |

**CHAPTER 5
APPEARANCE AND DIMENSIONS**

**CHAPTER 6
SAMPLE CIRCUIT BLOCK DIAGRAM**

**CHAPTER 7
DESIGNING AND HANDLING PRECAUTIONS**

| | | |
|-----|----------------------------|-----|
| 7.1 | DESIGN PRECAUTIONS | 7-1 |
| 7.2 | HANDLING PRECAUTIONS | 7-1 |

**CHAPTER 8
DESIGN OF PERIPHERAL DEVICES**

| | | |
|-------|---|-----|
| 8.1 | DESIGN PRECAUTIONS | 8-1 |
| 8.1.1 | MTP102 Printer | 8-1 |
| 8.1.2 | MTP201 and 401 Printers | 8-2 |
| 8.2 | MOUNTING THE PAPER CUTTER | 8-4 |
| 8.3 | MOUNTING A ROLL HOLDER FOR HEAD SENSITIVE PAPER | 8-5 |

| Section | Page |
|---|------|
| 8.4 THERMAL PAPER TAKE-UP DEVICE | 8-6 |
| 8.5 FLEXIBLE CABLE | 8-7 |
| 8.5.1 Connecting and Fixing the Flexible Cable Terminal | 8-7 |
| 8.5.2 Bend Radius of Flexible Cable | 8-7 |
| 8.6 REPLACEMENT OF HEAD UNIT | 8-8 |
| 8.6.1 Removing Head Unit | 8-8 |
| 8.6.2 Mounting the Head Unit..... | 8-10 |

TABLES

| Table | Page |
|--|------|
| 2-1 Character Printer Specifications | 2-2 |
| 2-2 Graphic Printer Specifications | 2-4 |
| 2-3 TG Output | 2-8 |

FIGURES

| Figure | Page |
|---|------|
| 2-1 Motor Drive Characteristics | 2-6 |
| 2-2 Motor Drive Signal Timing | 2-7 |
| 2-3 Sample Motor Drive Circuit | 2-7 |
| 2-4 Sample TG waveform shaping circuit | 2-8 |
| 2-5 TG Timing Signal | 2-8 |
| 2-6 OFF-to-ON Detection..... | 2-9 |
| 2-7 ON-to-OFF Detection..... | 2-9 |
| 2-8 Sample Thermal Head Drive Circuit | 2-11 |
| 2-9 Pulse Width Control | 2-13 |
| 2-10 Sample Pulse Width Control Circuit | 2-14 |

| Figure | Page |
|---|------|
| 3-1 Thermal Head Control Pin Assignment (B Head-mounted Printer)..... | 3-1 |
| 3-2 Motor and Switch Control Terminal Assignment (B Head-mounted Printer, MTP102) ... | 3-2 |
| 3-3 Motor and Switch Control Terminal Assignment (B Head-mounted Printer, MTP201 and MTP401) | 3-2 |
| 3-4 Thermal Head Control Terminal Assignment (G Head-mounted Printer) | 3-3 |
| 3-5 Motor and Switch Control Terminal Assignment (G Head-mounted Printer) | 3-3 |
| 4-1 Timing Chart | 4-2 |
| 4-2 Printing Start Timing Chart | 4-3 |
| 4-3 Continuous Printing Timing Chart (Home Switch Detection Method) | 4-3 |
| 4-4 Continuous Printing Timing Chart (Timing Signal Method) | 4-4 |
| 5-1 MTP102 (B head-mounted) Appearance and External Dimensions | 5-2 |
| 5-2 MTP201 (B head-mounted) Appearance and External Dimensions | 5-3 |
| 5-3 MTP401 (B head-mounted) Appearance and External Dimensions | 5-4 |
| 5-4 MTP201 (G head-mounted) Appearance and External Dimensions..... | 5-5 |
| 5-5 MTP401 (G head-mounted) Appearance and External Dimensions..... | 5-6 |
| 6-1 Sample Circuit Block Diagram (B Head-mounted Printer) | 6-2 |
| 6-2 Sample Circuit Block Diagram (G Head-mounted Printer) | 6-3 |
| 8-1 MTP102 Printer (Back) | 8-1 |
| 8-2 Mounting with Screws (MTP102 printer) | 8-1 |
| 8-3 Mounting without Screws (MTP102 printer) | 8-2 |
| 8-4 MTP201 and 401 Printers (Back) | 8-2 |
| 8-5 Mounting with Screws (MTP201 and 401 Printer)..... | 8-3 |
| 8-6 Mounting without Screws (MTP201 and 401 Printer)..... | 8-3 |
| 8-7 Mounting the Paper Cutter..... | 8-4 |
| 8-8 Mounting a Roll Holder for Heat Sensitive paper | 8-5 |
| 8-9 Roll without Core | 8-5 |
| 8-10 Bend Radius of Flexible Cable | 8-7 |
| 8-11 Moving the Head Carrier..... | 8-8 |
| 8-12 Removing the Flexible Lead Wire..... | 8-8 |
| 8-13 Pulling out the Flexible Cable Plate | 8-9 |
| 8-14 Pulling out the Head Unit..... | 8-9 |
| 8-15 Inserting the Head Unit Terminal..... | 8-10 |
| 8-16 Rotating the Head Portion of the Unit..... | 8-10 |
| 8-17 Sliding the Head along the Guide of the Head Carrier | 8-11 |
| 8-18 Pushing the Flexible Cable Plate..... | 8-11 |
| 8-19 Inserting the Flexible Cable | 8-11 |

CHAPTER 1

FEATURES

The MTP Series Line Thermal Printer Mechanism is a series of compact, thermal printers designed to meet the demand for small, low cost units. It can be used in adding machines, measuring instruments and analyzers, office machines, medical apparatus, and data terminal devices.

The MTP Series Line Thermal Printer Mechanism has the following features:

- Compact and light weight
- Maintenance-free
- High quality printing
- Battery drive
- Silent, nonimpact system
- Designed for versatile applications
- High reliability

2.2 GENERAL SPECIFICATIONS

2.2.1 Character Printers

Table 2-1 Character Printer Specifications

| Item | Specifications | | | | |
|---|---|--------------------------|--------------------------|--------------------------|--------------------------|
| Base model code | MTP102 | | MTP201 | | MTP401 |
| Model | MTP102-13B | MTP102-16B | MTP201-20B | MTP201-24B | MTP401-40B |
| Printing method | Thermal serial dot printing | | | | |
| Printing direction | Left to right with respect to the direction the paper is fed. | | | | |
| Dots per line (H×W / line) | 7 dots × 89 dots | 7 dots × 110 dots | 7 dots × 138 dots | 7 dots × 166 dots | 7 dots × 278 dots |
| Paper feed pitch (H×W) | 0.35mm × 0.30mm | 0.35mm × 0.24mm | 0.35mm × 0.33mm | 0.35mm × .28mm | 0.35mm × .24mm |
| Character matrix (H×W) | 7 × 5 dot matrix | | | | |
| Character size (H×W) | 2.4mm × 1.5mm | 2.4mm × 1.2mm | 2.4mm × 1.6mm | 2.4mm × 1.4mm | 2.4mm × 1.2mm |
| Characters per line | 13 dot (2 dot spaces) | 16 dot (2 dot spaces) | 20 dot (2 dot spaces) | 24 dot (2 dot spaces) | 40 dot (2 dot spaces) |
| Printing width | 26.7mm | 26.4mm | 45.9mm | 46.0mm | 66.7mm |
| Printing speed (room temperature, 5.0V) | Approx. 1.5 line / s | Approx. 1.2 lines / s | Approx. 1.0 line / s | Approx. 0.9 line / s | Approx. 0.5 line / s |
| Paper feed pitch | 3.8mm | | | | |
| Head activation timing detection | Via a tachogenerator | | | | |
| Home position detection | Via a mechanical switch | | | | |
| Operating voltage range | DC5.0V ± 1.0V | | | | |

Table 2-1 Character Printer specifications (continued)

| Item | | Specifications | | | | | | | | | | | | | | |
|--|-------------------|--|----------------------------------|----------------------------------|---------------------|--------|------------------|-------------------------|----------|------------|---------------------|---|-------|----------------------------|-----------|-----------|
| Base model code | | MTP102 | MTP201 | MTP401 | | | | | | | | | | | | |
| Current consumption (room temperature, 5.0V) | During printing | 3.2A max. | | | | | | | | | | | | | | |
| | During paper feed | 250mA max. | | | | | | | | | | | | | | |
| Operating temperature range | | 0 to 50 °C | | | | | | | | | | | | | | |
| Storage temperature range | | -40 to 60 °C | | | | | | | | | | | | | | |
| Life span | | 5 hundred thousand lines (5.0V rated energy, room temperature, "8" full line printing) ^{Note1} | | | | | | | | | | | | | | |
| Failure rate | | 10 ⁻⁶ / line or less (5.0V rated energy, room temperature, "8" full line printing) | | | | | | | | | | | | | | |
| Operating noise (room temperature, 5.0V) | | 70dB or less (back ground noise: 40dB or less, measuring distance: 15 cm, weighing: JIS A curve, dynamic characteristics: SLOW range) | | | | | | | | | | | | | | |
| Paper feed force | | 0.196N (20gf) or more | | 0.49N (50gf) or more | | | | | | | | | | | | |
| Paper hold force | | 0.49N (50gf) or more | | 0.98N (100gf) or more | | | | | | | | | | | | |
| Dimensions (W × D × H) | | 48 × 31 × 13.8mm | 70 × 34 × 14.4mm | 91.5 × 35.5 × 20mm | | | | | | | | | | | | |
| Mass | | Approx. 35g | Approx. 40g | Approx. 50g | | | | | | | | | | | | |
| Paper width | | 38 ⁰ ₋₁ mm | 58 ⁰ ₋₁ mm | 80 ⁰ ₋₁ mm | | | | | | | | | | | | |
| Paper thickness | | 65 ± 5 μm (59 ± 5 μm when using TF50KS-E2D) | | | | | | | | | | | | | | |
| Recommended thermal paper | | <table border="1"> <thead> <tr> <th>Maker / Sensitivity</th> <th>Normal</th> <th>High sensitivity</th> </tr> </thead> <tbody> <tr> <td>Nippon Paper Industries</td> <td>TP50KS-A</td> <td>TF50KS-E2D</td> </tr> <tr> <td>Oji Paper Co., Ltd.</td> <td>-</td> <td>PD450</td> </tr> <tr> <td>Mitsubishi Paper Co., Ltd.</td> <td>F-200U7N5</td> <td>F-200U9W3</td> </tr> </tbody> </table> | | | Maker / Sensitivity | Normal | High sensitivity | Nippon Paper Industries | TP50KS-A | TF50KS-E2D | Oji Paper Co., Ltd. | - | PD450 | Mitsubishi Paper Co., Ltd. | F-200U7N5 | F-200U9W3 |
| Maker / Sensitivity | Normal | High sensitivity | | | | | | | | | | | | | | |
| Nippon Paper Industries | TP50KS-A | TF50KS-E2D | | | | | | | | | | | | | | |
| Oji Paper Co., Ltd. | - | PD450 | | | | | | | | | | | | | | |
| Mitsubishi Paper Co., Ltd. | F-200U7N5 | F-200U9W3 | | | | | | | | | | | | | | |

Note1) Should be no scratches due to foreign material.

2.2.2 Graphic Printers

Table 2-2 Graphic Printer Specifications

| Item | Specifications | | |
|---|---|--------------------------|--------------------------|
| Base model code | MTP201 | | MTP401 |
| Model | MTP201-G128 | MTP201-G166 | MTP401-G280 |
| Printing method | Thermal serial dot printing | | |
| Printing direction | Left to right with respect to the direction the paper is fed. | | |
| Dots per line (H×W / line) | 8 dots × 128 dots | 8 dots × 166 dots | 8 dots × 280 dots |
| Paper feed pitch (H×W) | 0.35mm × 0.35mm | 0.35mm × 0.28mm | 0.35mm × 0.24mm |
| Character matrix (H×W) | 7 × 5 dot matrix | | |
| Character size (H×W) | 2.4mm × 1.7mm | 2.4mm × 1.4mm | 2.4mm × 1.2mm |
| Character per line | 18 dot (2 dot spaces) | 24 dot (2 dot spaces) | 40 dot (2 dot spaces) |
| Printing width | 44.7mm | 46.0mm | 67.2mm |
| Printing speed (room temperature, 5.0V) | Approx. 0.9 line / s | Approx. 0.9 line / s | Approx. 0.5 line / s |
| Paper feed pitch | 2.8mm | | |
| Head activation timing detection | Via a tachogenerator | | |
| Home position detection | Via a mechanical switch | | |
| Operating voltage range | DC5.0V ± 1.0V | | |

Table 2-2 Graphic Printer Specifications (continued)

| Item | | Specifications | | | | | | | | | | | | | |
|--|-------------------|--|----------------------------------|---------------------|--------|------------------|-------------------------|----------|------------|---------------------|---|-------|----------------------------|-----------|-----------|
| Base model code | | MTP201 | MTP401 | | | | | | | | | | | | |
| Current consumption (room temperature, 5.0V) | during printing | 3.2A max. | | | | | | | | | | | | | |
| | during paper feed | 250mA max | | | | | | | | | | | | | |
| Operating temperature range | | 0 to 50°C | | | | | | | | | | | | | |
| Storage temperature range | | -40 to 60°C | | | | | | | | | | | | | |
| Life span | | 5 hundred thousand lines (5.0V rated energy, room temperature, "8" full line printing) ^{Note1} | | | | | | | | | | | | | |
| Failure rate | | 10 ⁻⁶ / line or less (5.0V rated energy, room temperature, "8" full line printing) | | | | | | | | | | | | | |
| Operating noise (room temperature, 5.0V) | | 70dB or less (back ground noise: 40dB or less, measuring distance: 15cm, weighing network: JIS A curve, dynamic characteristics: SLOW range) | | | | | | | | | | | | | |
| Paper feed force | | 0.196N (20gf) or more | | | | | | | | | | | | | |
| Paper hold force | | 0.49N (50gf) or more | 0.98N (100gf) or more | | | | | | | | | | | | |
| Dimensions (W × D × H) | | 70 × 34 × 14.4mm | 91.5 × 35.5 × 20mm | | | | | | | | | | | | |
| Mass | | Approx. 40g | Approx. 50g | | | | | | | | | | | | |
| Paper width | | 58 ⁰ _{.1} mm | 80 ⁰ _{.1} mm | | | | | | | | | | | | |
| Paper thickness | | 65 ± 5 μm (59 ± 5 μm when using TF50KS-E2D) | | | | | | | | | | | | | |
| Recommended thermal paper | | <table border="1"> <thead> <tr> <th>Maker / sensitivity</th> <th>Normal</th> <th>High sensitivity</th> </tr> </thead> <tbody> <tr> <td>Nippon Paper Industries</td> <td>TP50KS-A</td> <td>TF50KS-E2D</td> </tr> <tr> <td>Oji Paper Co., Ltd.</td> <td>-</td> <td>PD450</td> </tr> <tr> <td>Mitsubishi Paper Co., Ltd.</td> <td>F-200U7N5</td> <td>F-200U9W3</td> </tr> </tbody> </table> | | Maker / sensitivity | Normal | High sensitivity | Nippon Paper Industries | TP50KS-A | TF50KS-E2D | Oji Paper Co., Ltd. | - | PD450 | Mitsubishi Paper Co., Ltd. | F-200U7N5 | F-200U9W3 |
| Maker / sensitivity | Normal | High sensitivity | | | | | | | | | | | | | |
| Nippon Paper Industries | TP50KS-A | TF50KS-E2D | | | | | | | | | | | | | |
| Oji Paper Co., Ltd. | - | PD450 | | | | | | | | | | | | | |
| Mitsubishi Paper Co., Ltd. | F-200U7N5 | F-200U9W3 | | | | | | | | | | | | | |

Note1) Should be no scratches due to foreign material.

2.3 MOTOR DRIVER CHARACTERISTICS

The motor is the power source for head movement and paper feed. Through the application of DC voltage to the motor, the head automatically moves back and forth, and paper fed on its return; therefore, there is no need to reverse the motor.

- | | |
|-----------------------------|---|
| (1) Motor terminal voltage | 5.0 ± 1.0 V DC |
| (2) Motor power consumption | |
| During printing | 170 mA max. (room temperature, room humidity, 5.0 V DC) |
| During paper feeding | 250 mA max. (room temperature, room humidity, 5.0 V DC) |
| Commencing movement | 700 mA max. (room temperature, room humidity, 5.0 V DC) |
| Ceasing movement | 500 mA max. (room temperature, room humidity, 5.0 V DC) |

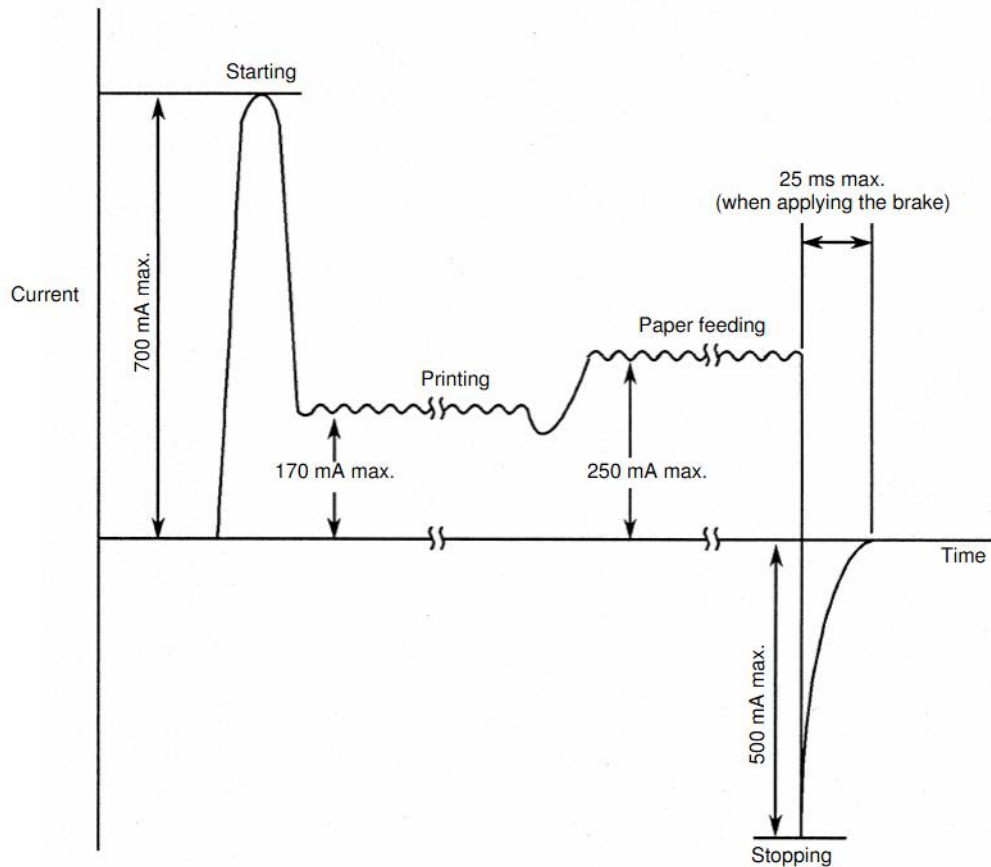
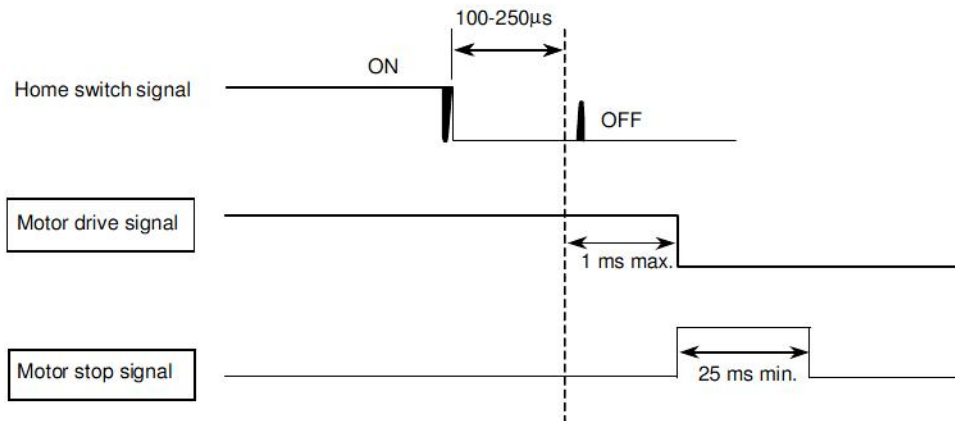

Figure 2-1 Motor Drive Characteristics

(3) Motor stop signal

Stop the motor drive signal within 1 ms after detecting a home switch "OFF" (100 to 250 μ s) signal, and input a motor stop signal of at least 25 ms.



* See Section 2.5, Home Switch, for home switch signal.

Figure 2-2 Motor Drive Signal Timing

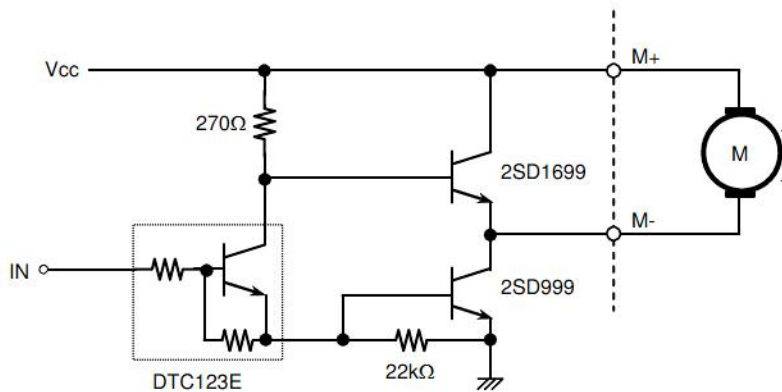

* When using this circuit, a motor stop signal is not required.

Figure 2-3 Sample Motor Drive Circuit

2.4 TG (TACHO-GENERATOR) OUTPUT CHARACTERISTICS

The TG is a signal generator directly connected to the motor, that generates false sine waves of two cycles per 1 turn of the motor. These waves are converted by a waveform shaping circuit into rectangular wave signals, which are used as a pulse impression timing signal for the thermal head.

(1) TG output

Table 2-3 TG Output

| | 4 to 6V | 5V |
|-----------------------|------------|------------|
| Output voltate (Vp-p) | 2.0 to 7.0 | 3.5 to 6.0 |
| Period (ms) | 2.5 to 6.5 | 3.0 to 5.0 |

(2) Sample TG waveform shaping circuit

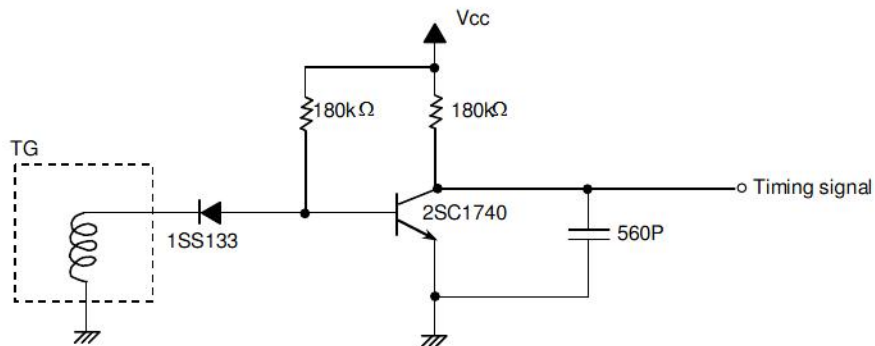
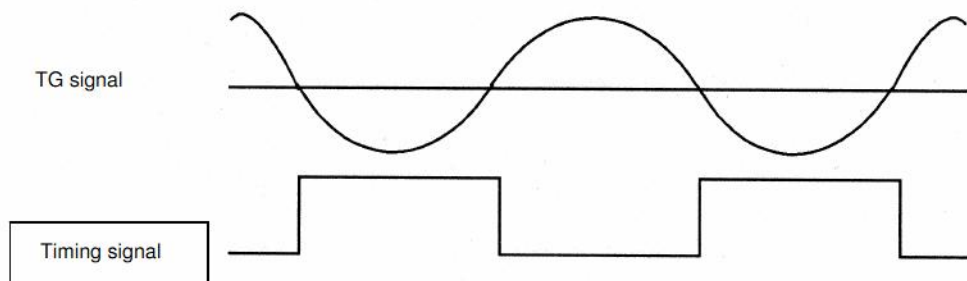

Figure 2-4 Sample TG waveform shaping circuit



* Generation of the timing signals depends on the user.

Figure 2-5 TG Timing Signal

2.5 HOME SWITCH

The home switch is a push-open type mechanical switch, which switches "OFF" when the head is at the home position (left end). The switch has two functions. The first is to detect the home position when the head stops there. Upon returning to the home position, the home switch switches from "ON" to "OFF", and brakes are applied to stop the motion of the print head.

The second function is it is used as reference point for starting the counting of the print timing signals. As the head begins to move to the right from the home position, the home switch switches from "OFF" to "ON", at which point counting of the print timing signal begins (TG signals after waveform shaping).

- (1) Contact resistance
5 Ω max. (measuring current: 50 μ A)
- (2) Current
1.0 mA max. (5.0 V DC)
- (3) OFF-to-ON detection

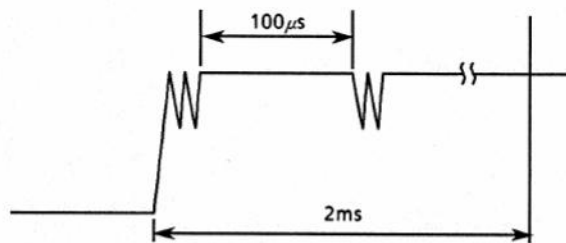

Figure 2-6 OFF-to-ON Detection

This switch has the characteristics that the ON state exists for more than 100 μ s within 2 ms of when the home switch switches from OFF-to-ON. Do not detect the switch until after 1-line has printed after detection of the first ON detection.

- (4) ON-to-OFF detection

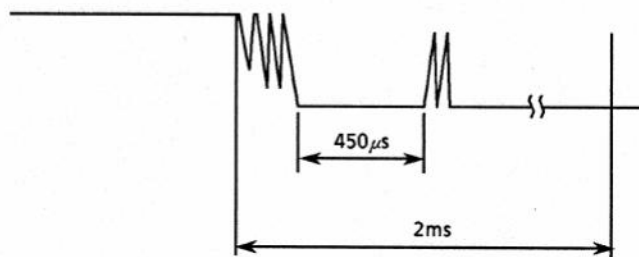

Figure 2-7 ON-to-OFF Detection

This switch has the characteristics that the OFF state exists for more than 450 μ s within 2 ms of when the home switch switches from ON-to-OFF. Do not detect the switch for 10 ms after detection of OFF.

2.6 THERMAL PRINT HEAD

Because the thermal print head in the MTP Series is a thin film type with high thermal efficiency, it has an excellent print quality. The CPU determines which vertically placed heating units to energize, and drives them with the thermal head driver (transistor).

2.6.1 Head Specifications

| Type of Head | | B head | G Head |
|---|--------|--|-----------|
| Heating unit size | | | |
| Resistance value* | A rank | 15.3 ± 1Ω | 17.6 ± 1Ω |
| | B rank | 14.0 ± 1Ω | 16.0 ± 1Ω |
| | C rank | 12.7 ± 1Ω | 14.4 ± 1Ω |
| Head applied voltage | | DC 5.0 ± 1V (at FPC terminal) | |
| Peak current (in simultaneous drive of all dots at 5.0 V DC) | | 3.0A max. | 3.0A max. |
| Head applied energy (24°C, 5.0V) | Rated | High sensitive thermal paper 2.30mJ Standard thermal paper 2.50mJ | |
| | Max. | 3.00mJ | 3.00mJ |

* The resistance value of each dot in the same head may have a 5% dispersion rate, and the average values are indicated on the rank table above. Rank symbols are printed on the FPC.

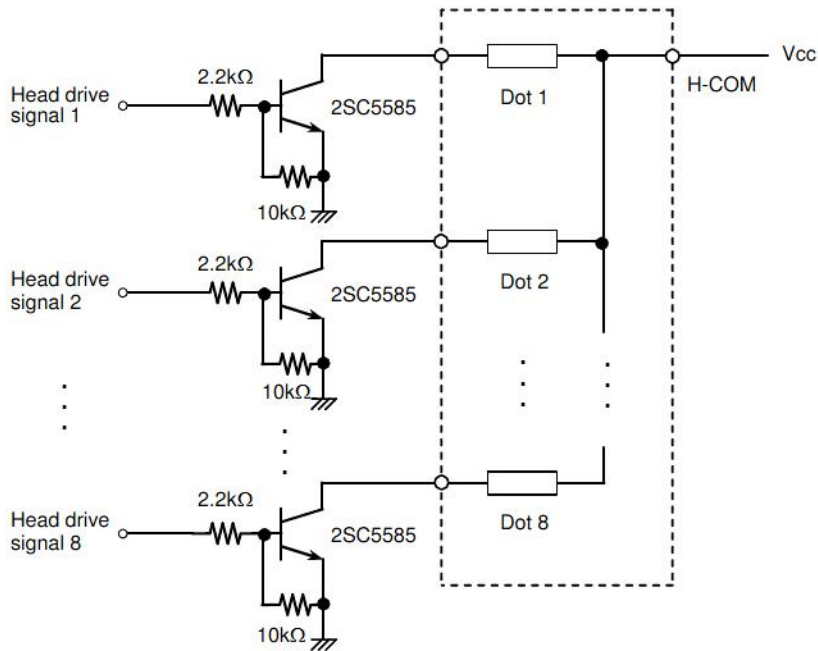

Figure 2-8 Sample Thermal Head Drive Circuit

2.6.2 Head Applied Energy Correction

Use the Applied Energy Correction Formula below to correct for when the power voltage and ambient temperature fluctuation during operation (see sample pulse width control circuit).

Applied energy correction formula

$$E = \frac{V_0 + V}{2V} E_0 \left(1 + \frac{T_0 - T}{100} \right)$$

E: Applied energy (mJ)
 V: FPC terminal volatage (V)
 T: Temperature (°C)
 E₀: Rated energy (mJ)

| | B head | G head |
|------------------------------|--------|--------|
| High sensitive thermal paper | 2.3mJ | 2.3mJ |
| Standard thermal paper | 2.5mJ | 2.5mJ |

V₀: Rated voltage (5.0V)
 T₀: Room temperature (24°C)

2.6.3 Head Activation Pulse Width

To ensure high quality printing with the MTP Series, the thermal head activation pulse width must be set according to the head drive voltage and the head resistance.

Pulse width calculation formula

$$t = \frac{R \cdot E}{V^2}$$

t: Pulse width for applying rated energy (ms)

R: Head resistance (Ω)

| | B head | G head |
|--------|---------------|---------------|
| A rank | 15.3 Ω | 17.6 Ω |
| B rank | 14.0 Ω | 16.0 Ω |
| C rank | 12.7 Ω | 14.4 Ω |

E: Applied energy (mJ)

V: FPC terminal volatge (V)

Note: Procedure for pulse width adjustment

- (1) Minimize pulse width.
- (2) Activate the thermal head with a checked pattern.
- (3) Measure the head terminal voltage by using a synchroscope.
- (4) Gradually adjust applied pulse width, which is calculated by using the pulse width calculation formula.

2.6.4 Control of Printing Pulse Width

Superior print quality can be maintained by controlling the print pulse width by the print pulse width control circuit. This is an oscillating circuit in which the frequency varies depending upon the voltage and ambient temperature, and provides a specified pulse width by counting a certain number of pulses with the CPU.

The leading edge of the pulse is synchronized with the timing signal. Control the leading edge of the pulse by the pulse width control circuit to obtain the rated applied energy.

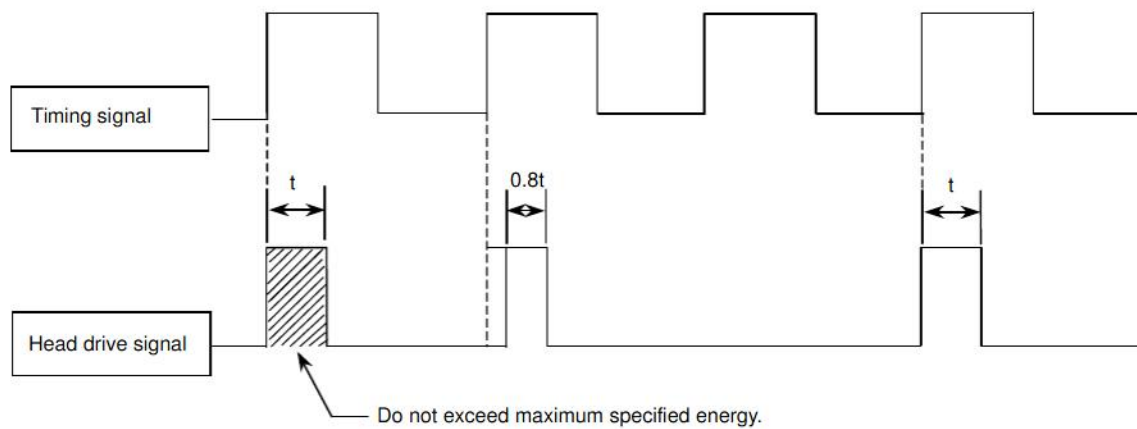
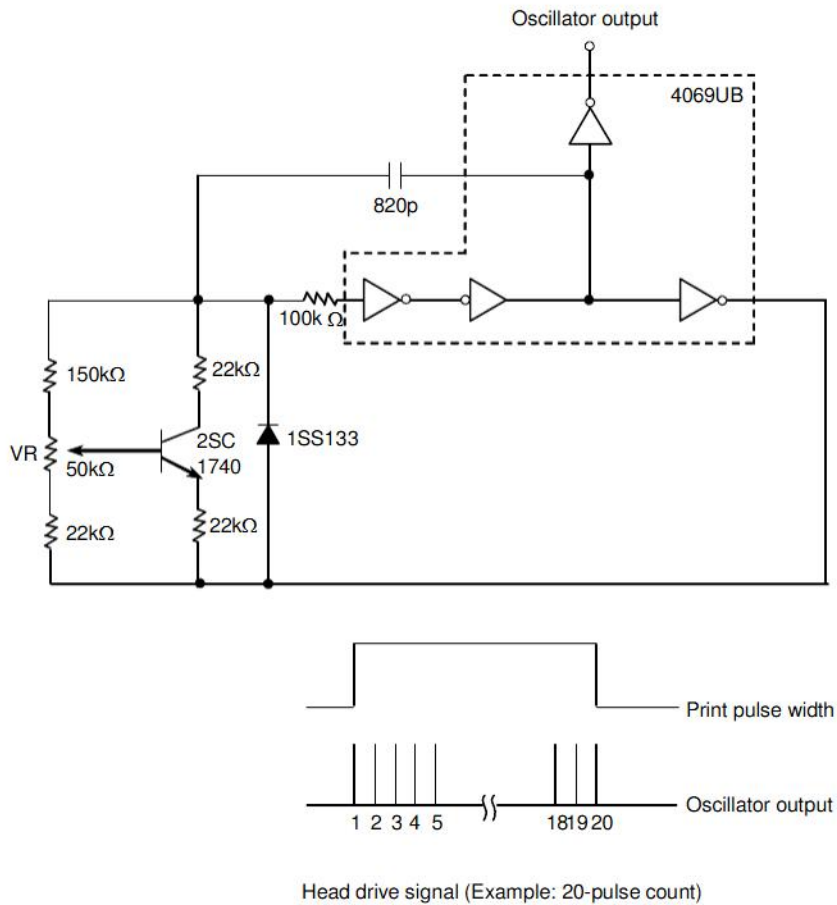

Figure 2-9 Pulse Width Control

- Avoid continuous energizing.
- When driving the same dot successively, reduce the applied energy to 80% of the rated applied energy and slow down the rise of the head driving signal.



- * The compensation circuits for temperature and voltage are included.
- * Adjust an oscillating frequency with VR to obtain the proper pulse width in 20 counts at the normal temperature.
- * A print pulse width is made by counting the above oscillator output with the CPU.

Figure 2-10 Sample Pulse Width Control Circuit

2.6.5 Initialization

Feed out the paper by one line and stop the print head at the home position after turning on the power.

2.6.6 Paper Feeding

Paper is fed automatically upon input of a motor drive signal. After paper is fed, the head must stop always at the home position.

CHAPTER 3
TERMINAL ASSIGNMENT

3.1 B HEAD-MOUNTED PRINTER

3.1.1 Thermal Head Control Terminal

Recommended connector: 0022023083 (MOLEX)

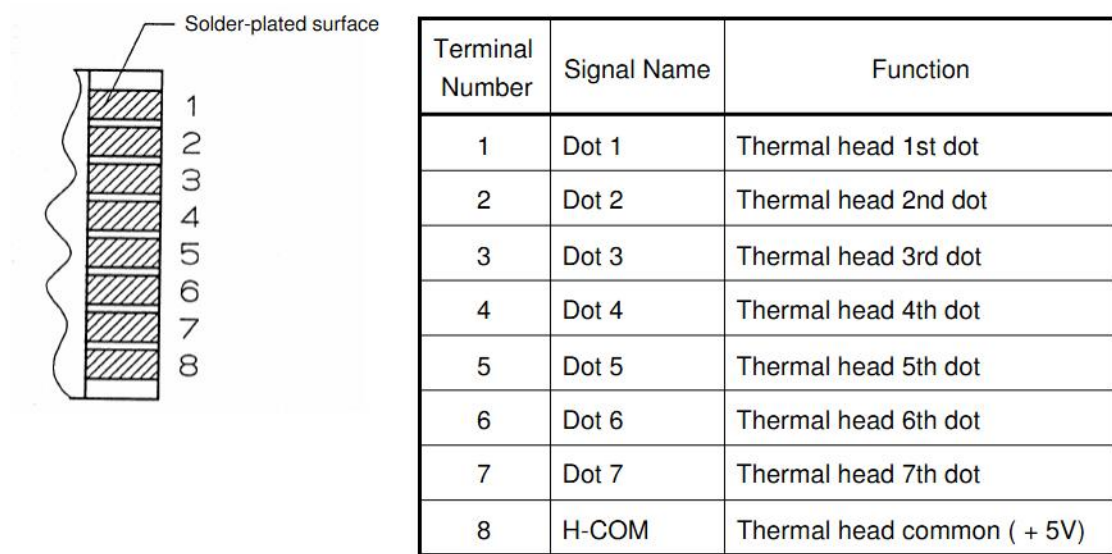
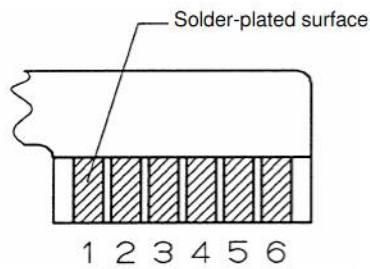

Figure 3-1 Thermal Head Control Terminal Assignment (B Head-mounted Printer)

3.1.2 Motor and Switch Control Terminal

(1) MTP102

Recommended connector: 0022023063 (MOLEX)



| Terminal Number | Signal Name | Function |
|-----------------|-------------|----------------------------------|
| 1 | HS | Home switch, GND for V_{CC} |
| 2 | HS | |
| 3 | TG | Tachogenerator, GND for V_{CC} |
| 4 | TG | |
| 5 | M - | Motor minus |
| 6 | M + | Motor plus (+ 5V) |

Figure 3-2 Motor and Switch Control Terminal Assignment (B Head-mounted Printer, MTP102)

(2) MTP201 and MTP401

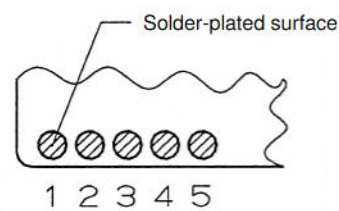

| Terminal Number | Signal Name | Function |
|-----------------|-------------|---|
| 1 | M + | Motor plus (+ 5V) |
| 2 | M - | Motor minus |
| 3 | TG | Tachogenerator |
| 4 | HS·TG·COM | Home switch·Tachogenerator common (GND) |
| 5 | HS | Home switch |

Figure 3-3 Motor and Switch Control Terminal Assignment (B Head-mounted Printer, MTP201 and MTP401)

3.2 G HEAD-MOUNTED PRINTER

3.2.1 Thermal Head Control Terminal

Recommended connector: 0022023093 (MOLEX)

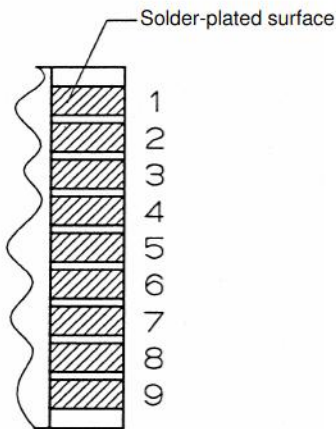

| Terminal Number | Signal Name | Function |
|-----------------|-------------|-----------------------------|
| 1 | Dot 1 | Thermal head 1st dot |
| 2 | Dot 2 | Thermal head 2nd dot |
| 3 | Dot 3 | Thermal head 3rd dot |
| 4 | Dot 4 | Thermal head 4th dot |
| 5 | Dot 5 | Thermal head 5th dot |
| 6 | Dot 6 | Thermal head 6th dot |
| 7 | Dot 7 | Thermal head 7th dot |
| 8 | Dot 8 | Thermal head 8th dot |
| 9 | H-COM | Thermal head common (+ 5V) |

Figure 3-4 Thermal Head Control Terminal Assignment (G Head-mounted Printer)

3.2.2 Motor and Switch Control Terminal

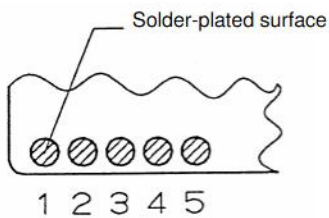

| Terminal Number | Signal Name | Function |
|-----------------|-------------|---|
| 1 | M + | Motor plus (+ 5V) |
| 2 | M - | Motor minus |
| 3 | TG | Tachogenerator |
| 4 | HS-TG-COM | Home switch-Tachogenerator common (GND) |
| 5 | HS | Home switch |

Figure 3-5 Motor and Switch Control Terminal Assignment (G Head-mounted Printer)

CHAPTER 4

TIMING CHART

4.1 TIMING CHART

Figure 4-1 shows the timing chart when using a B-head mounted printer. The number of the head drive signal depends on the type of thermal head mounted on the printer.

* Signal in are issued from the circuit side.

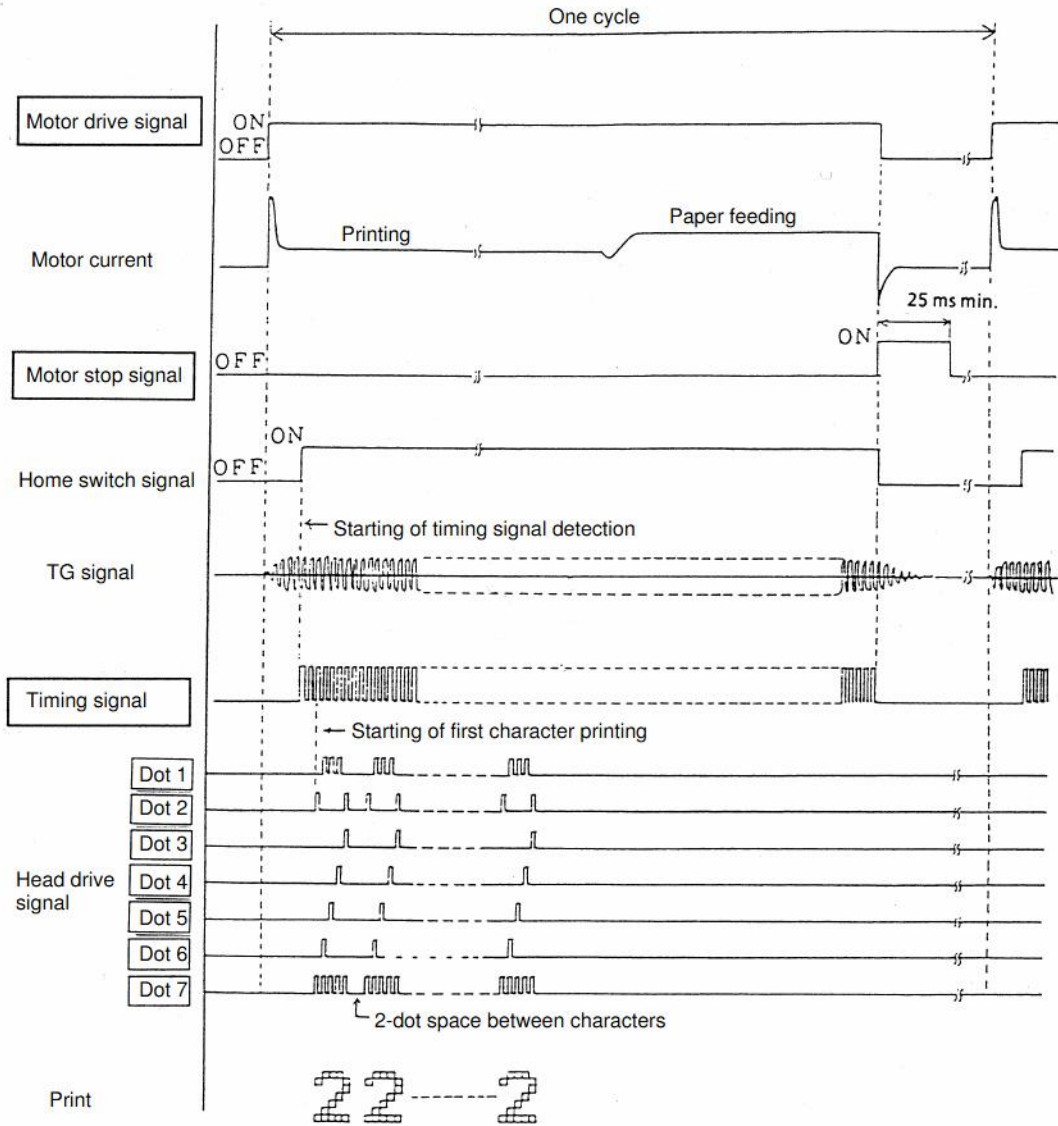

Figure 4-1 Timing Chart

4.2 DETAILED CHART OF PRINTING START TIMING

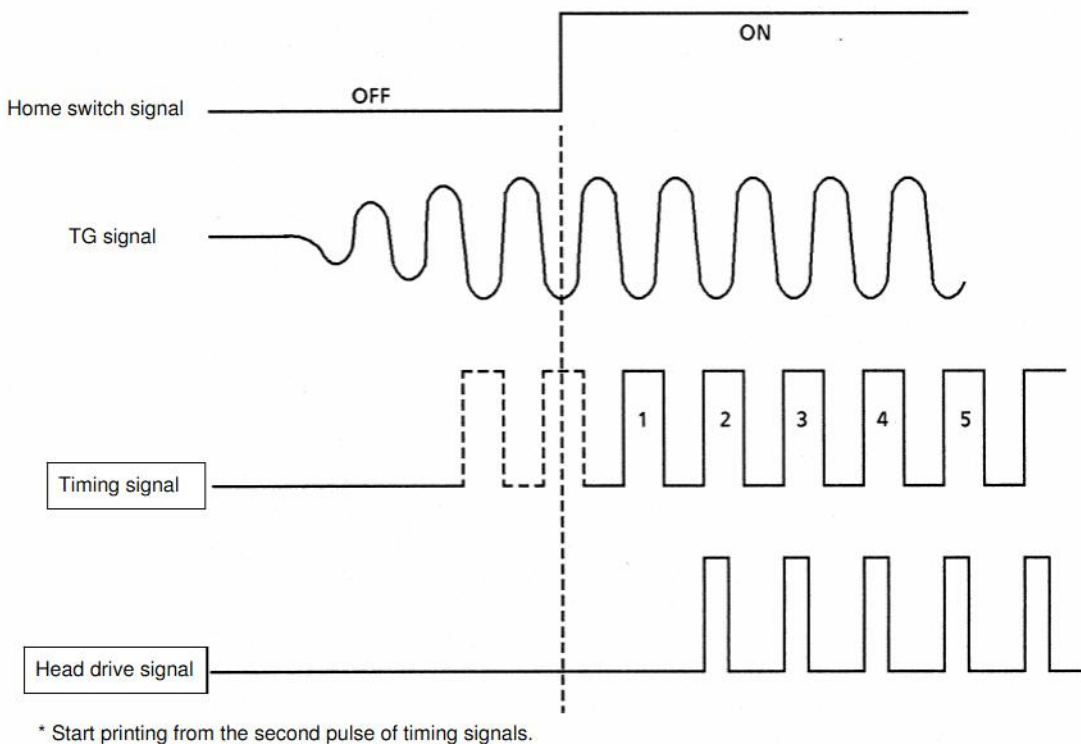

Figure 4-2 Printing Start Timing Chart

4.3 CONTINUOUS PRINTING OPERATION

4.3.1 Home Switch Signal Method

The print start position is determined for each line on the basis of the ON-rise of the home switch signal.

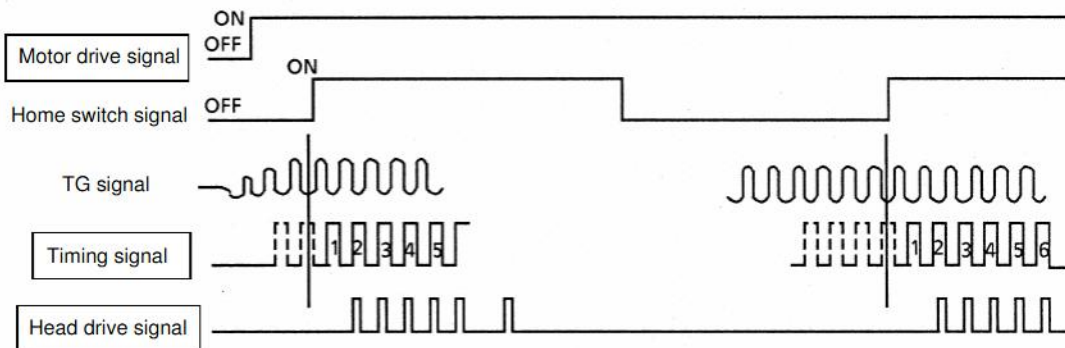

Figure 4-3 Continuous Printing Timing Chart (Home Switch Detection Method)

- Due to a detection error of the home switch signal, the print start position may deviate by a maximum of 1 dot.

N is as shown below:

| Part Number | N |
|-------------|-----|
| MTP102-13B | 160 |
| -16B | 200 |
| MTP201-20B | 230 |
| -24B | 276 |
| MTP401-40B | 450 |

| Part Number | N |
|-------------|-----|
| MTP201-G128 | 276 |
| -G166 | 276 |
| MTP401-G280 | 450 |

CHAPTER 5
APPEARANCE AND DIMENSIONS

Figures 5-1 to 5-5 shows the appearance and external dimensions of the MTP Series printer mechanisms.

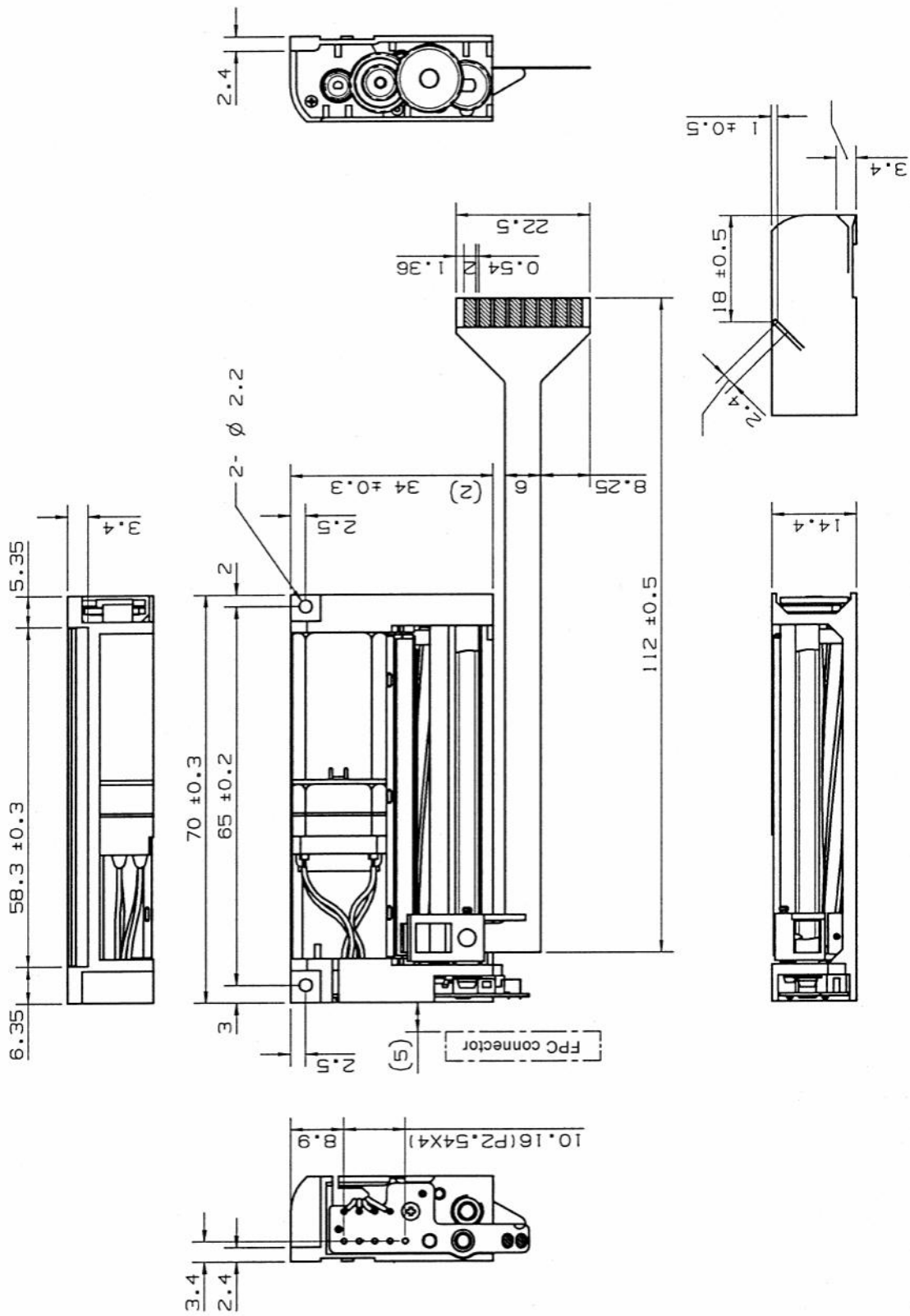

Figure 5-2 MTP201 (B head-mounted) Appearance and External Dimensions

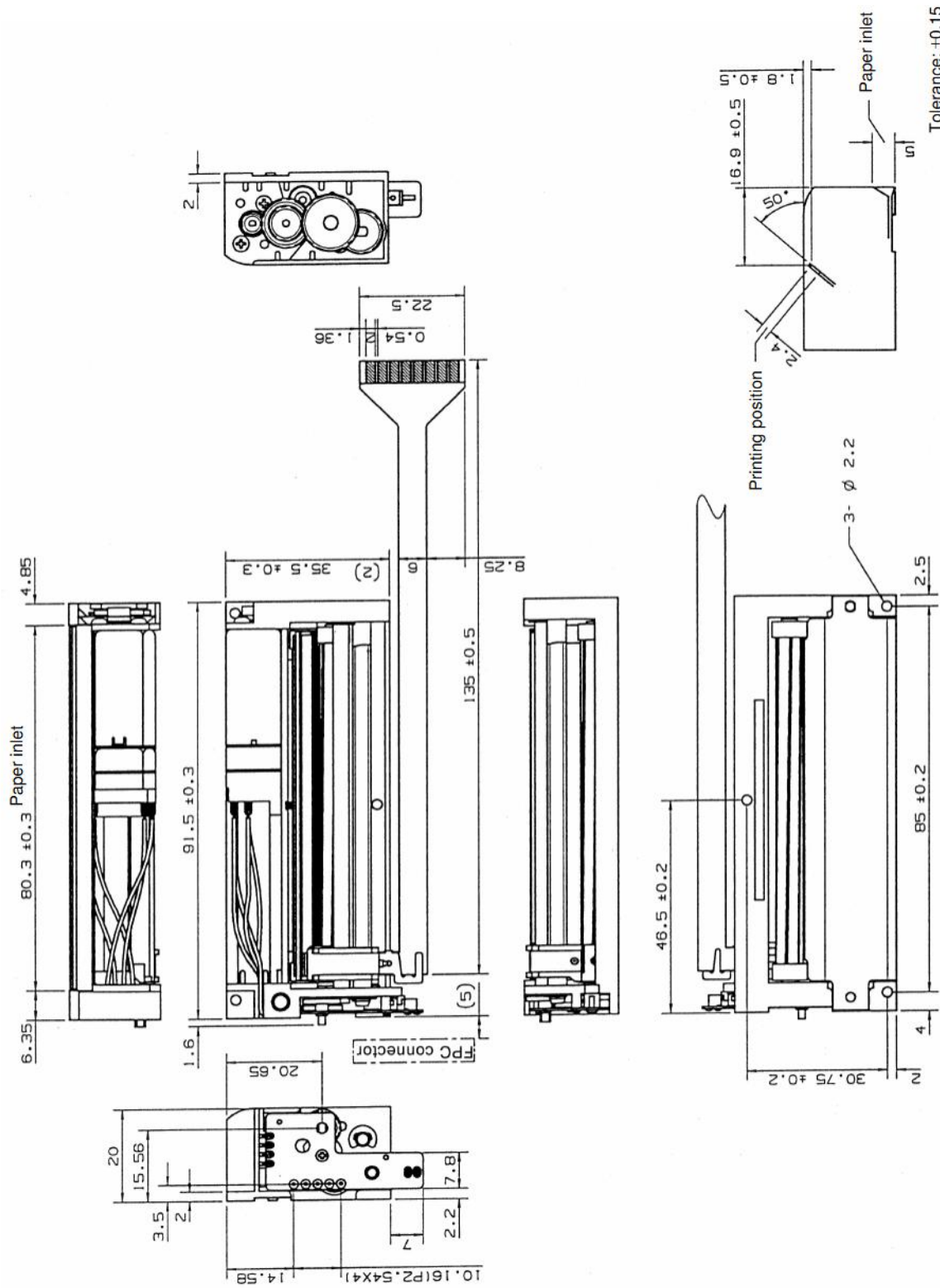

Figure 5-3 MTP401 (B head-mounted) Appearance and External Dimensions

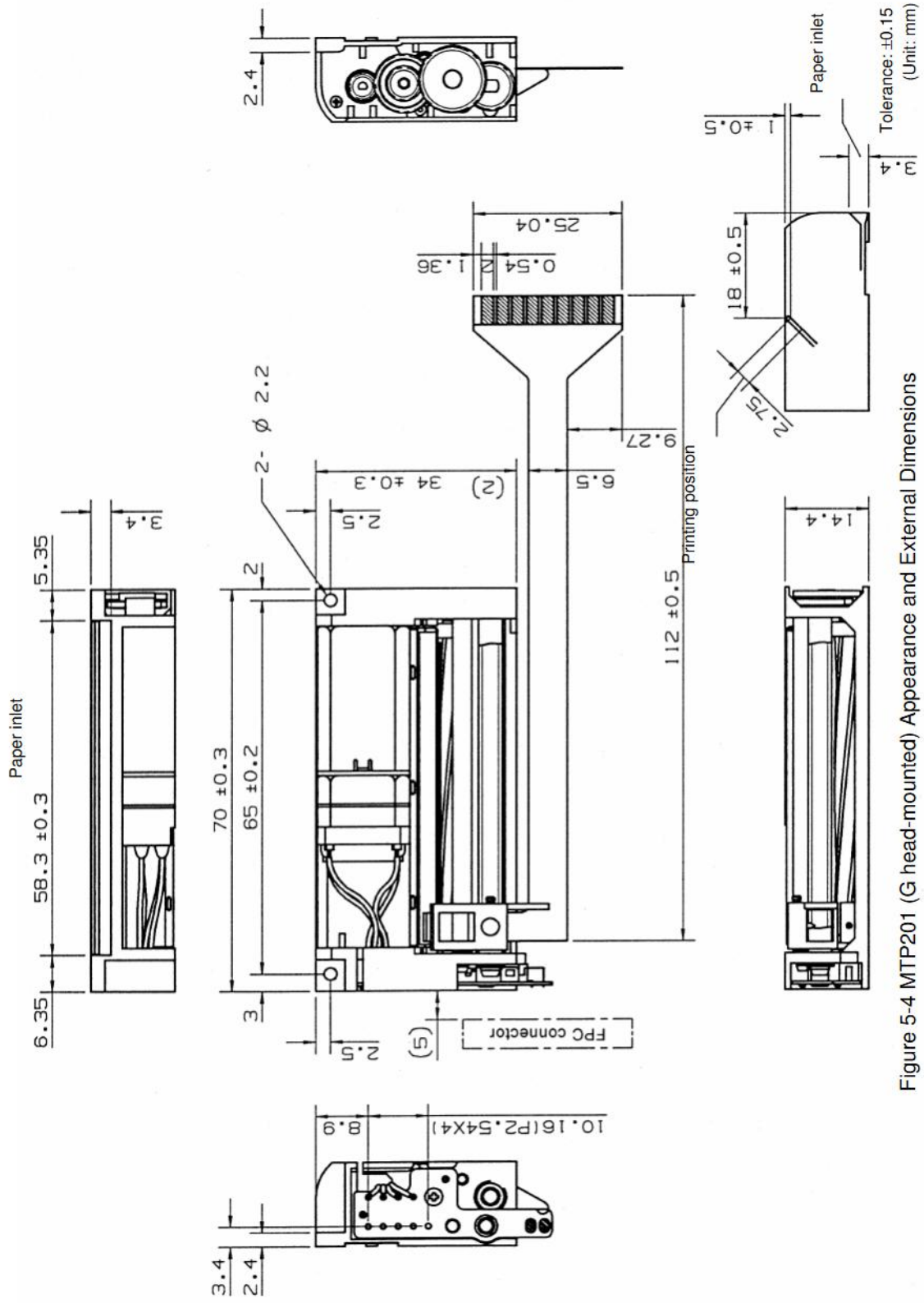

Figure 5-4 MTP201 (G head-mounted) Appearance and External Dimensions

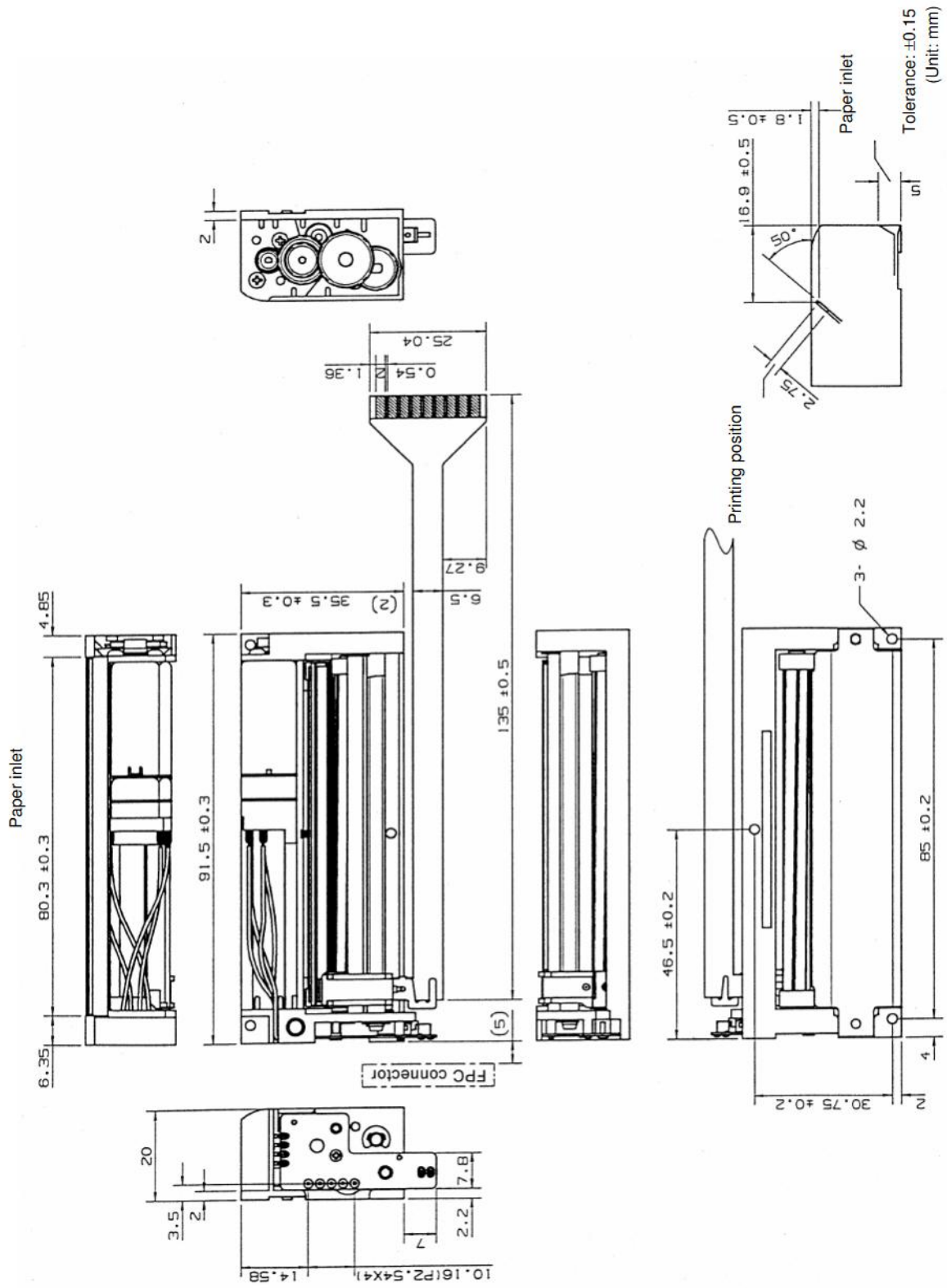

Figure 5-5 MTP401 (G head-mounted) Appearance and External Dimensions

CHAPTER 6
SAMPLE CIRCUIT BLOCK DIAGRAM

Figures 6-1 and 6-2 shows the samples of the circuit block diagrams.

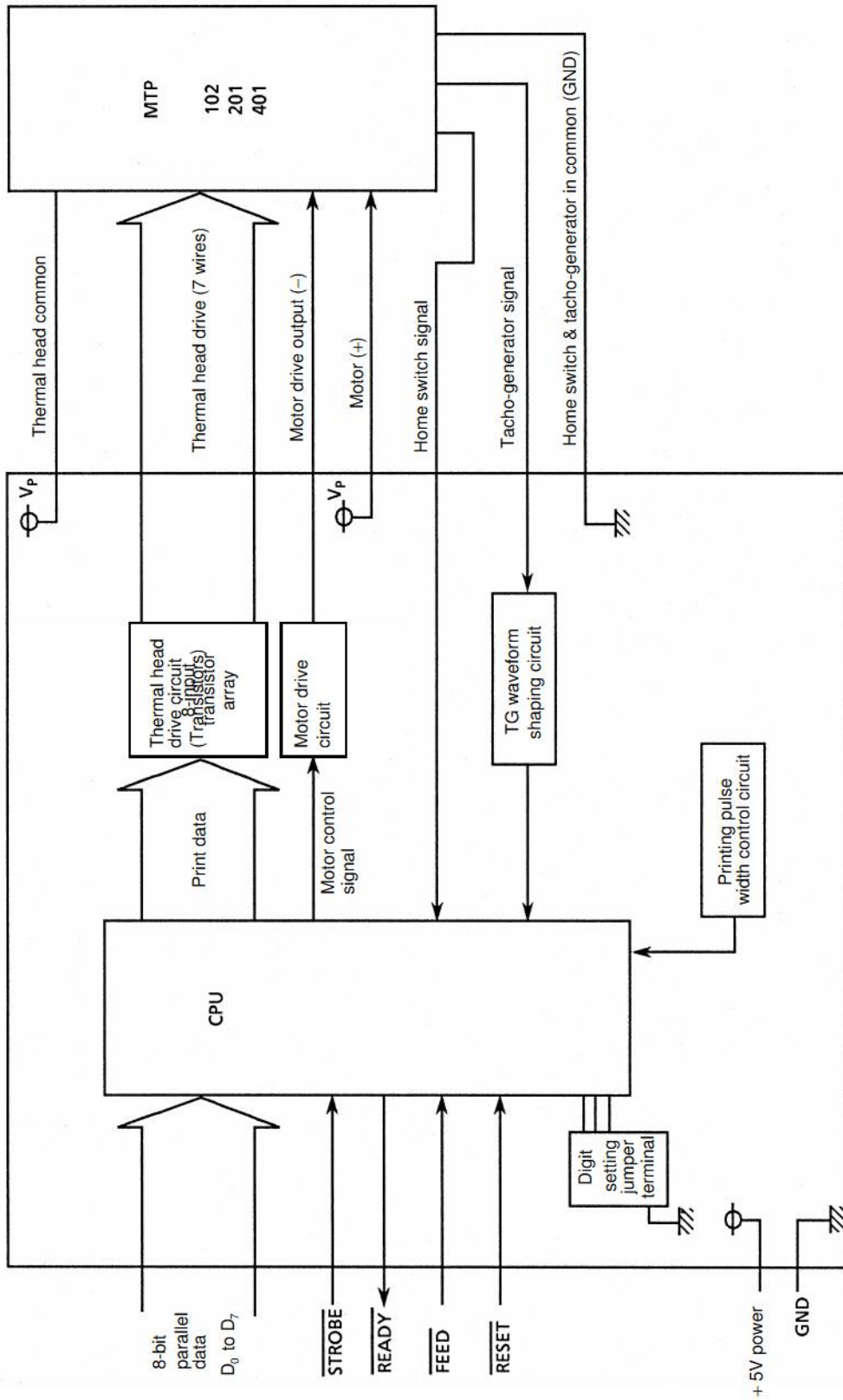

Figure 6-1 Sample Circuit Block Diagram (B Head-mounted Printer)

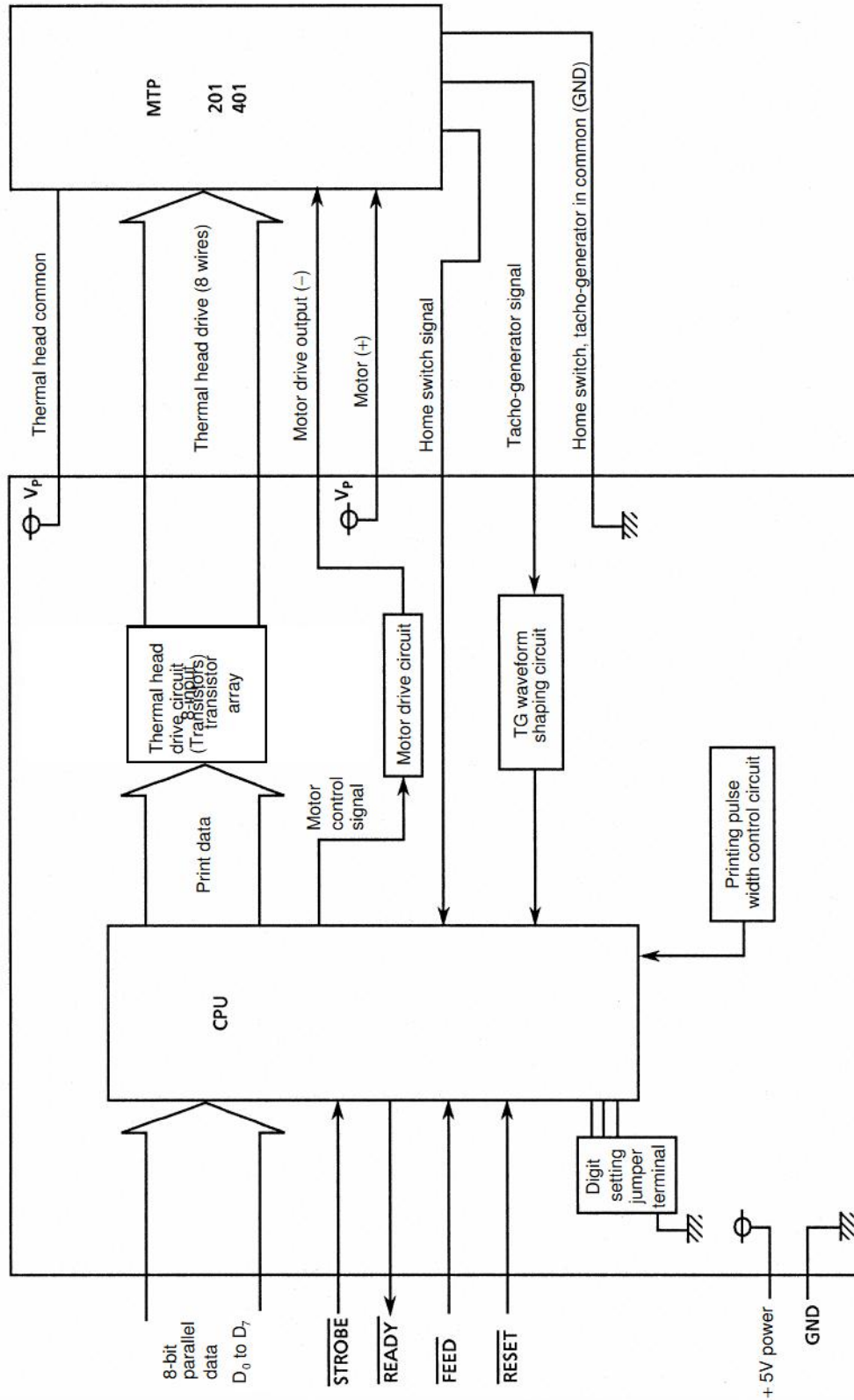

Figure 6-2 Sample Circuit Block Diagram (G Head-mounted Printer)

CHAPTER 7

DESIGNING AND HANDLING PRECAUTIONS

To maintain the performance of the MTP Series and to prevent future problems from occurring, observe the following precautions.

7.1 DESIGN PRECAUTIONS

- (1) Do not apply an energy source that is too high.

If too much energy is applied to the thermal head, it may overheat and become damaged. Always use the printer with the specified pulse width.

- (2) Stop activating to the motor if the thermal head does not return to the home position because of a paper jam (the home switch signal detection is not executed).
- (3) If the MTP Series is used at extremely high temperature or at high humidity, the thermal head may be electrolytically corroded. To prevent the thermal head from being electrolytically corroded:
 - Keep the thermal paper away from the ground.
 - Turn OFF the Vp power supply when not printing.

7.2 HANDLING PRECAUTIONS

- (1) If any paper other than that specified is used, the high print quality and long life of the thermal head can not be guaranteed.

Possible problems that may occur:

- Poor print quality due to low-sensitivity paper
- Abrasion of the thermal head due to paper surface which is too rough
- Print fading due to low print preservation
- Corrosion of the thermal head
- Poor print quality due to paper trash attachment

- (2) Stop the thermal head at the home position; otherwise, the platen may become deformed resulting in poor print quality.
- (3) Do not print without paper; otherwise, the platen or thermal head may become damaged.
- (4) Do not damage the platen by removing paper when a paper jam occurs.
- (5) Cut the edge of the paper so that the corners of the paper are square (90°); otherwise, a paper jam may occur.

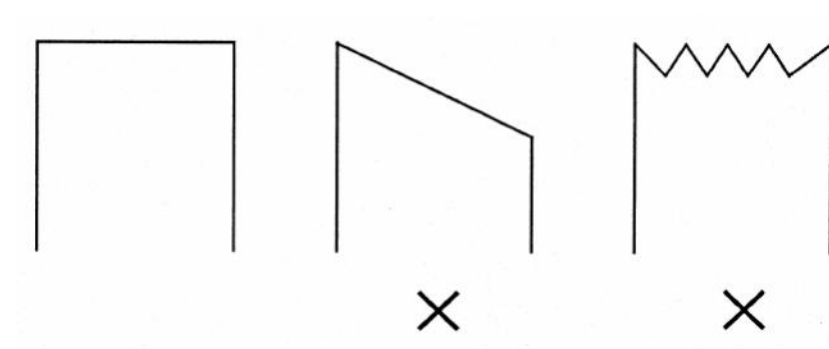

- (6) Unload paper in the direction in which the paper is normally fed. If paper is unloaded in the reverse direction, the paper feed mechanism may become damaged.
- (7) Do not use a thermal paper roll whose core and the paper are attached; otherwise, the paper will lock causing the paper feed to suddenly increase the amount fed resulting in damage to the paper feed mechanism.
- (8) Remove the debris on the surface of the paper; otherwise, a paper jam may occur.

CHAPTER 8

DESIGN OF PERIPHERAL DEVICES

8.1 DESIGN PRECAUTIONS

The mounting procedure for MTP Series printers differs somewhat between the MTP102 and the other printers in the series.

Mount the printer so that it is not warped or distorted in any way.

8.1.1 MTP102 Printer

The MTP102 is provided on its back two dowels and two holes diagonally for mounting the printer (see Figure 8-1).

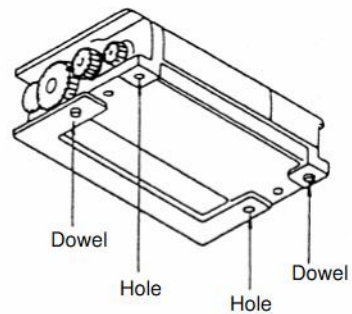

Figure 8-1 MTP102 Printer (Back)

(1) When mounting with screws

Mount the printer by tightening the tapping screws from under the mounting base.

In this case, the dowels are used as a reference for positioning (see Figure 8-2).

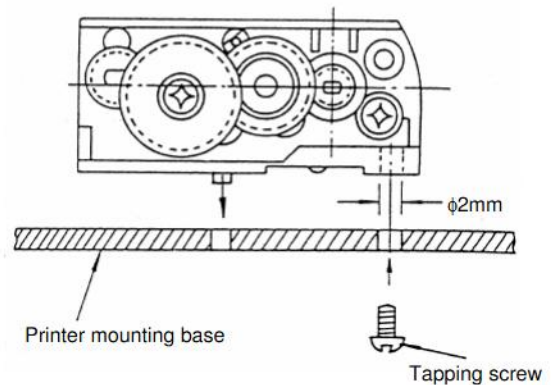

Figure 8-2 Mounting with Screws
(MTP102 Printer)

(2) When mounting without screws

Using the dowels and the $\phi 2$ mm holes on the back of the printer as reference for positioning, fix the printer by pressing the eaves on both sides of the upper portion of the printer (see Figure 8-3).

Do not push on the eaves at the motor end.

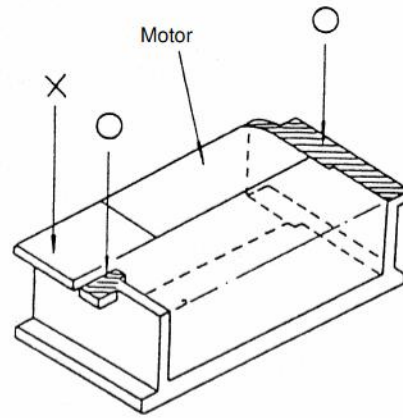

Figure 8-3 Mounting without Screws
(MTP102 printer)

8.1.2 MTP201 and 401 Printers

The MTP201 and 401 printers are provided with $\phi 2.2$ mm mounting holes at the two corners of the printer (see Figure 8-4).

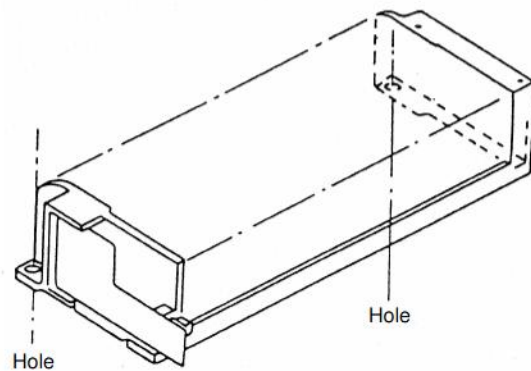

Figure 8-4 MTP201 and 401 Printers (Back)

(1) When mounting with screws

With the $\phi 2.2$ mm holes at the corners of the printer as a reference for positioning, fix the printer on the printer base by tightening the tapping screws from the top of the printer (see Figure 8-5).

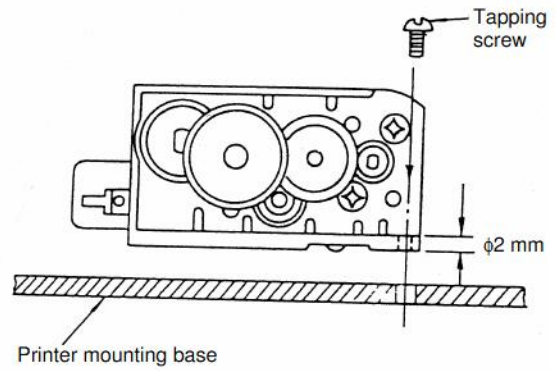

Figure 8-5 Mounting with Screws
(MTP201 and 401 Printer)

(2) When mounting without screws

With the $\phi 2.2$ mm holes as a reference for positioning, fix the printer by pressing the eaves on both sides of the upper portion of the printer.

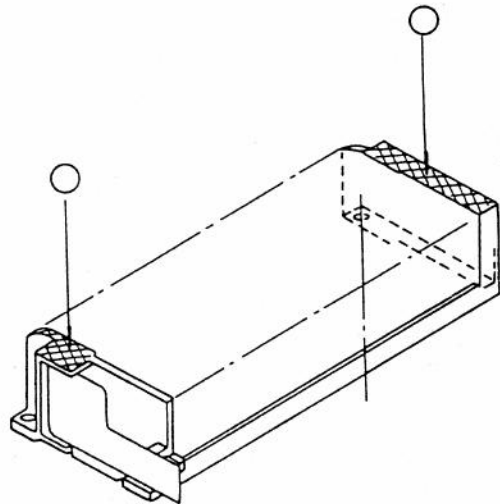

Figure 8-6 Mounting without Screws
(MTP201 and 401 Printer)

8.2 MOUNTING THE PAPER CUTTER

Design the paper cutter so that the cutter tip is located over the paper outlet so that it does not interrupt the paper flow (see Figure 8-7). Design any peripheral devices so that the paper does not re-enter the printer.

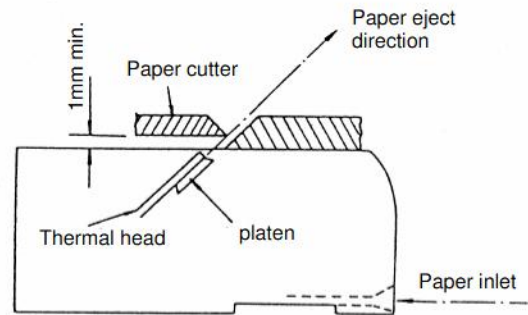
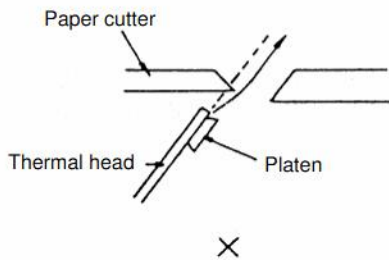
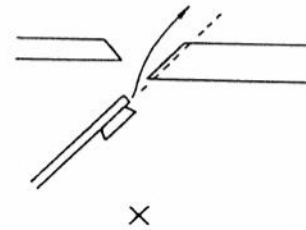

Figure 8-7 Mounting the Paper Cutter

Examples of improper designs:



This type of design may cause improper contact between the platen and the thermal head leading to deterioration in the quality of the print.



This type of design may cause damage to the paper surface. Furthermore, it may apply excessive force on the thermal head when cutting the paper.

Design conditions:

The paper-hold tension indicates the opposing force produced when the paper is pulled out through the outlet. It is expressed as "X N or more" in the specifications. As this is a specification for the printer, design the paper cutter so that paper must be cut with an opposing force of "X N or less".

8.3 MOUNTING A ROLL HOLDER FOR HEAD SENSITIVE PAPER

Design the roll holder to the following specifications:

- 1) No sideways deviation between holder and inlet.
- 2) Less than 2 mm between holder and the sides of the roll.
- 3) The holder does not touch the sides of the roll.
- 4) The horizontal axis of the roll in the holder is parallel with the inlet(see Figure 8-8).

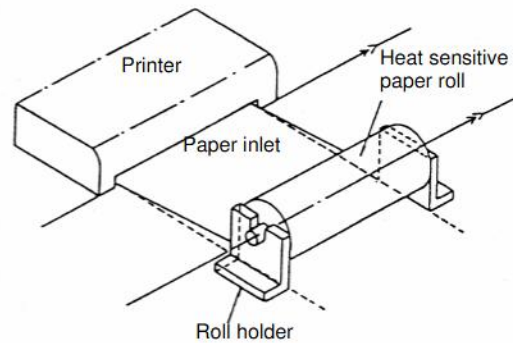
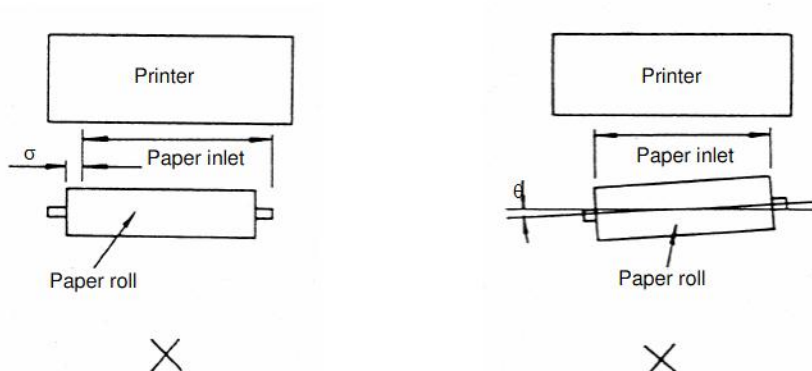

Figure 8-8 Mounting a Roll Holder for Heat Sensitive paper

Example of improper design:



- Roll without core
 - 1) The roll rolls easily.
 - 2) The roll remains securely in the holder.

Design conditions:

The paper feed tension is expressed as "X N or more" in the specifications. Since this is a specification for the printer feed, design the roll holder so that the paper tension is "X N or less".

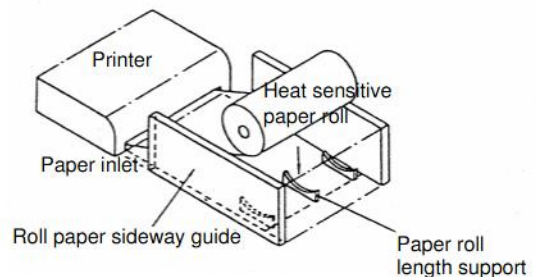

Figure 8-9 Roll without Core

8.4 THERMAL PAPER TAKE-UP DEVICE

Take into consideration the following items when designing the thermal paper take-up device.

- 1) After printing, the paper must be taken up without being pulled taut.
- 2) Even when paper guides have attached as shown below, if the thermal paper is pulled taut, correct contact between the thermal head and the thermal paper can not be obtained and printing will be adversely affected.

<Improper thermal paper take-up device>

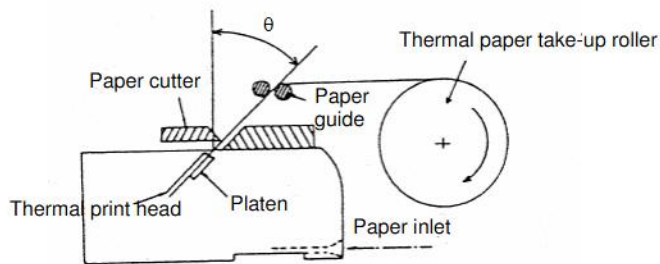

<Proper thermal paper take-up device>

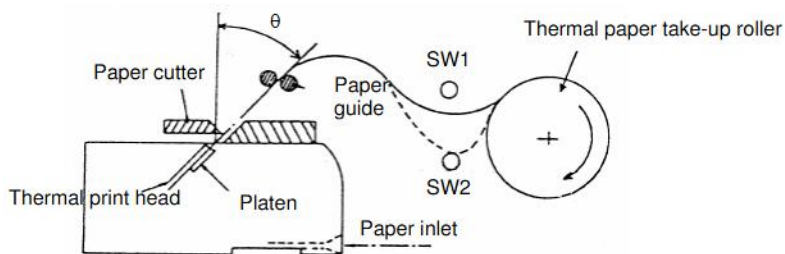

Take-up roller operates when SW2 is ON.
Take-up roller stops when SW1 is ON.

8.5 FLEXIBLE CABLE

8.5.1 Connecting and Fixing the Flexible Cable Terminal

Use and FPC (Flexible Printed Circuit) connector to connect and fix the flexible cable terminal. Refer to the external view of each printer for the mounting position of the FPC connector.

8.5.2 Bend Radius of Flexible Cable

Design the case of peripheral device to provide for a minimum radius of at least 5R (mm) at the point where the flexible cable bends.

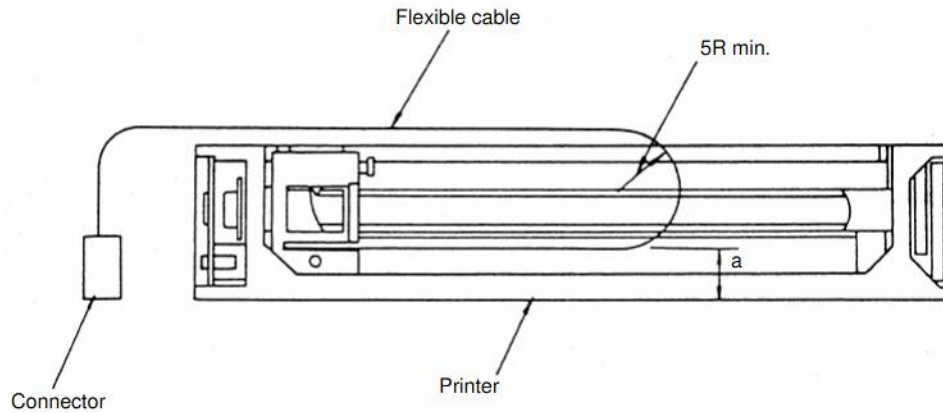

| Base Model | a (mm) |
|------------|--------|
| MTP 102 | 5.3 |
| MTP 201 | 5.3 |
| MTP 401 | 8.0 |

Figure 8-10 Bend Radius of Flexible Cable

8.6 REPLACEMENT OF HEAD UNIT

The model which can replace the head unit is the printer of MTP 401 series.

8.6.1 Removing Head Unit

- (1) Move the head carrier to position A by turning the motor gear by hand to allow easy replacement of the head unit (see figure 8-11).

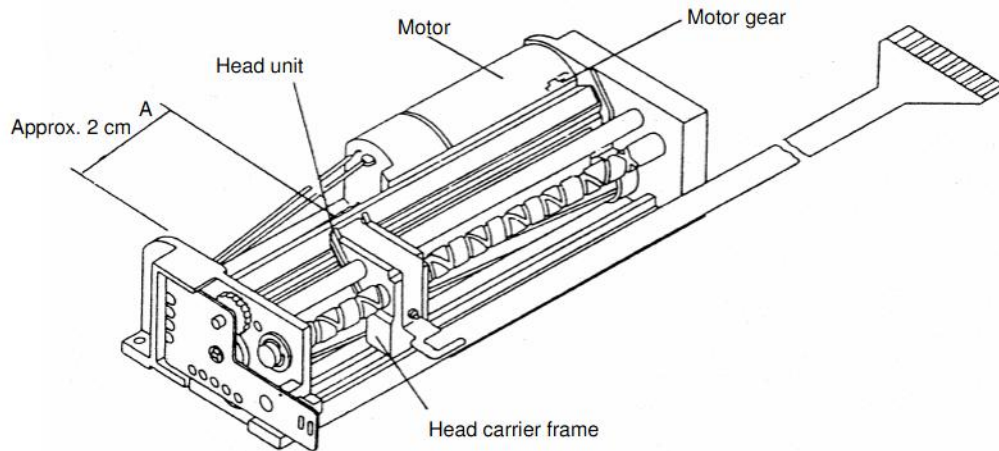

Figure 8-11 Moving the Head Carrier

- (2) Remove the flexible lead wire from the cable support of the flexible cable plate. Take the adhesive off of the cable support with tweezers.

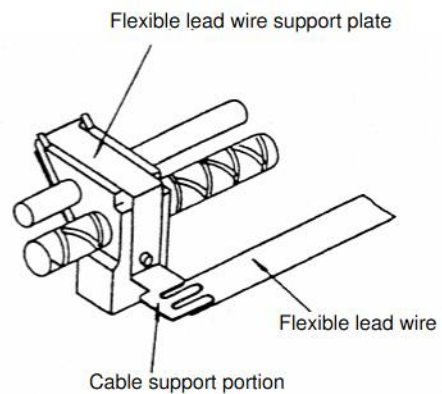

Figure 8-12 Removing the Flexible Lead Wire

- (3) Pull out the flexible cable plate in the direction shown by arrow A holding the edge of the plate with a finger, then disengage the plate from the dowel of the head carrier (see figure 8-13).

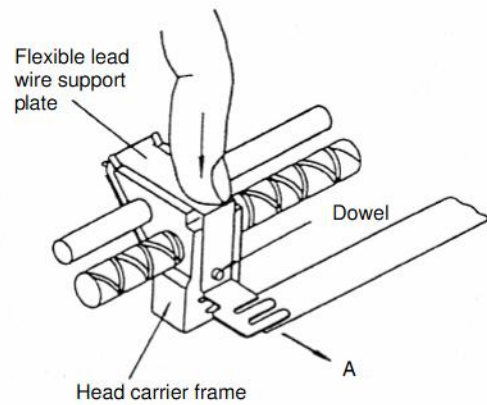

Figure 8-13 Pulling out the Flexible Cable Plate

- (4) Holding both sides of the head unit with your fingers, pull out the head unit in the direction shown by arrow B (see Figure 8-14).

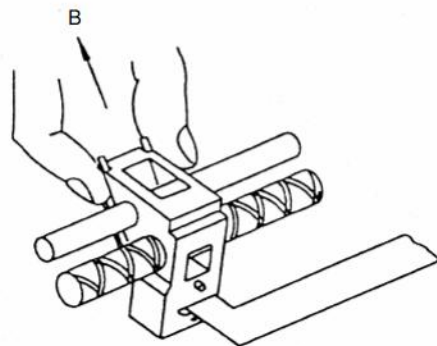

Figure 8-14 Pulling out the Head Unit

8.6.2 Mounting the Head Unit

- (1) Move the head carrier to a position that permits easy replacement (see Figure 8-15).
- (2) Insert the head unit terminal between the platen and the guide pin and head feeding screw with the soldered surface of the head screw upwards (see Figure 8-15). Holding the solder-plated face upward, insert the head unit terminal so that it passes in front of the platen and under the guide pin and the head feed screw.

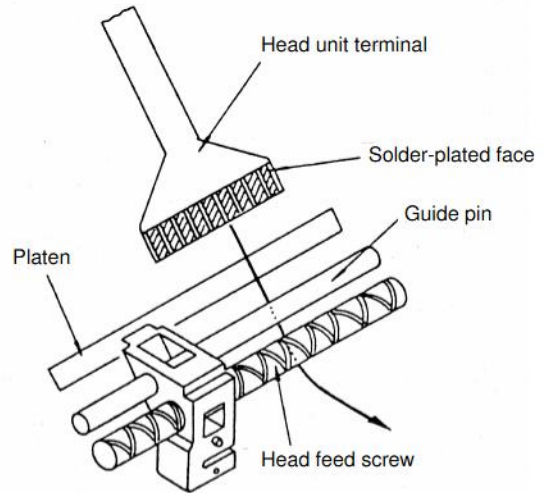

Figure 8-15 Inserting the Head Unit Terminal

- (3) After inserting the head unit terminal, arrange the components as shown in Figure 8-16. Then, rotate the head portion of the unit by 90° into the position shown in Figure 8-17.

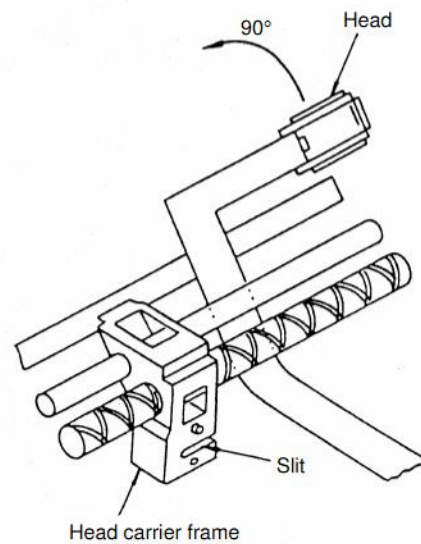

Figure 8-16 Rotating the Head Portion of the Unit

- (4) Slide the head unit terminal cable into the slit provided on the head carrier. Next, slide the head along the guide of the head carrier until it touches the guide (see Figure 8-17).

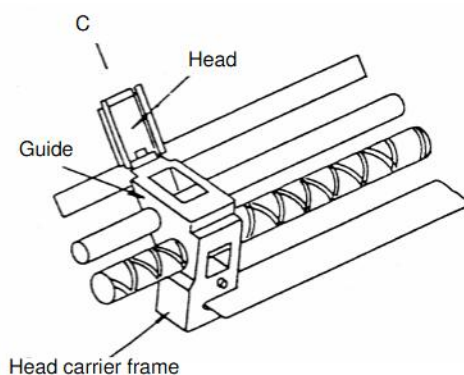

Figure 8-17 Sliding the Head along the Guide of the Head Carrier

- (5) Latch the flexible cable plate to the claws of the head and push it down until engages with the dowel on the head carrier.

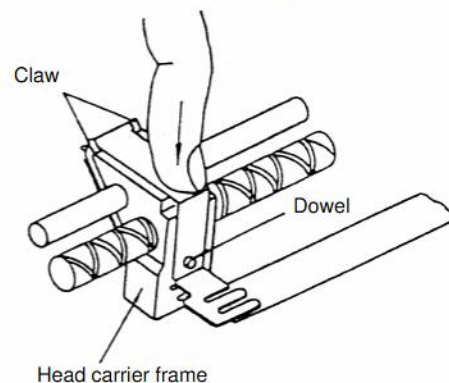

Figure 8-18 Pushing the Flexible Cable Plate

- (6) Insert the flexible cable into the cable support of the flexible cable plate with care not to bend the heat compressor of the head unit (see figure 8-19).

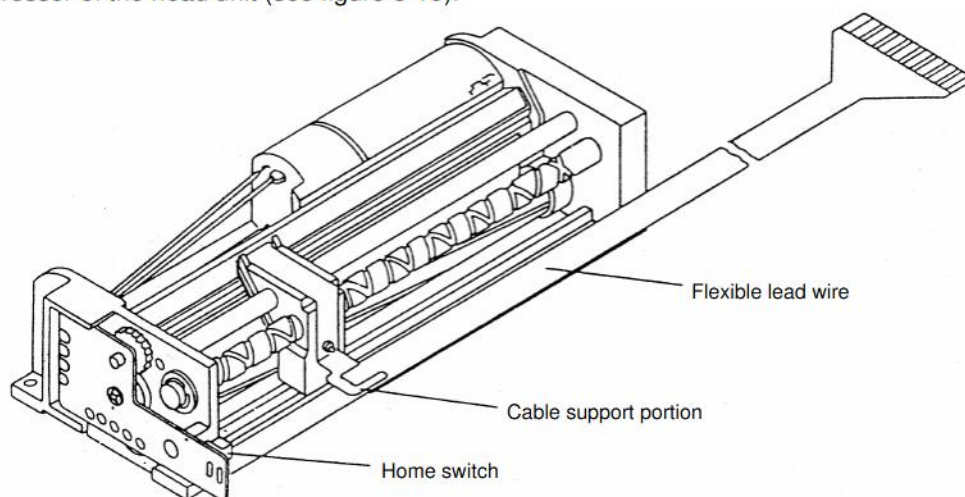

Figure 8-19 Inserting the Flexible Cable

- (7) Return the head carrier to the home position (home switch side).