

TECHNICAL GUIDE

SEIKO DIGITAL QUARTZ

CAL. A927A

CAL. A939A



CONTENTS

I. SPECIFICATIONS	1
II. STRUCTURE OF THE CIRCUIT BLOCK	1
III. DISPLAY FUNCTION	3
IV. DISASSEMBLING, REASSEMBLING AND LUBRICATING.....	4
V. CHECKING AND ADJUSTMENT	5
• Check battery voltage	5
• Check battery conductivity.....	5
• Check current consumption	5
• Check water resistance	6
• Check contact between C-MOS-LSI and liquid crystal panel.....	6
• Check liquid crystal panel and circuit block	6
• Check accuracy	6
• Check functioning and adjustment	6
• Check alarm test system	6
• Check conductivity of switch components	6
• Check alarm condition	7
• Check bulb condition	7
• Check functioning.....	7

I. SPECIFICATIONS

Item	Cal. No.	A939A	A927A
Display medium		Nematic Liquid Crystal, FEM (Field Effect Mode)	
Liquid crystal driving system		Multiplex driving system	
Display system		<ul style="list-style-type: none"> • Time and calendar function (12 or 24 hour indication) • Stopwatch function 	
		<ul style="list-style-type: none"> • Alarm function (12 or 24 hour indication) • Interval timer function 	
Additional mechanism		<ul style="list-style-type: none"> • Pattern segment checking system • Automatic calendar display system • Illuminating light • Automatic return system 	
		<ul style="list-style-type: none"> • Time signal • Alarm test system 	
Loss/gain		Loss/gain at normal temperature range Monthly rate: less than 15 seconds (Annual rate: less than 3 minutes)	
Outside diameter		φ28.1 mm	
Height		4.9 mm without battery	
Regulation system		Trimmer condenser	
Measuring gate by Quartz Tester		Any gate is available.	
Battery		Lithium battery Maxell CR2016, National BR2016 Battery life is approximately 5 years. Voltage: 3.0V	

II. STRUCTURE OF THE CIRCUIT BLOCK

- The upconverter coil, the resistance for buzzer, and the transistor for buzzer are not attached to the circuit block of Cal. A927A.

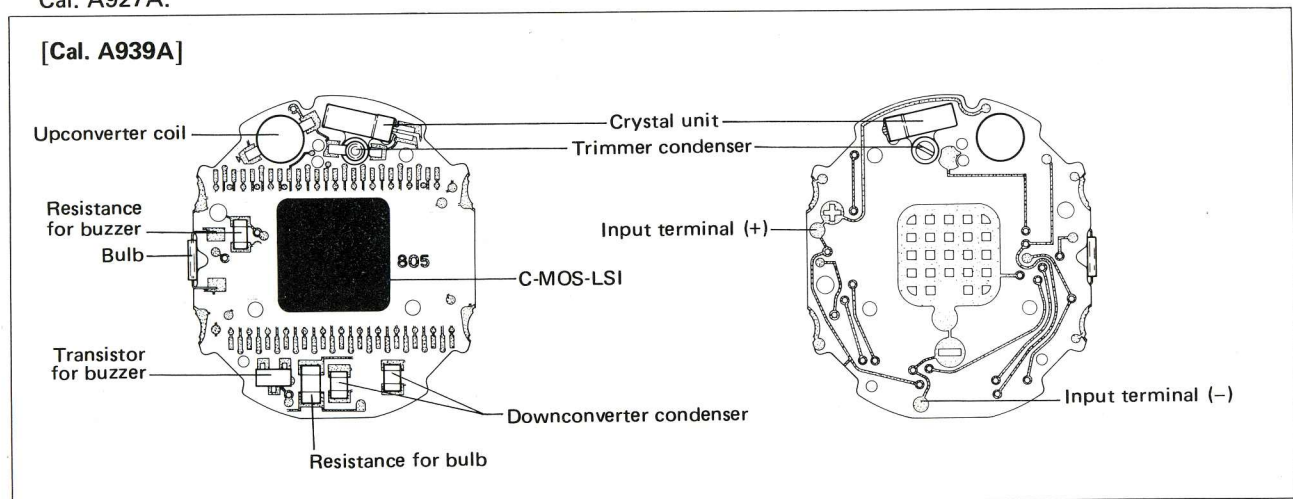

III. DISPLAY FUNCTION

- Check to see if the display changes as shown below by each depression of button A.

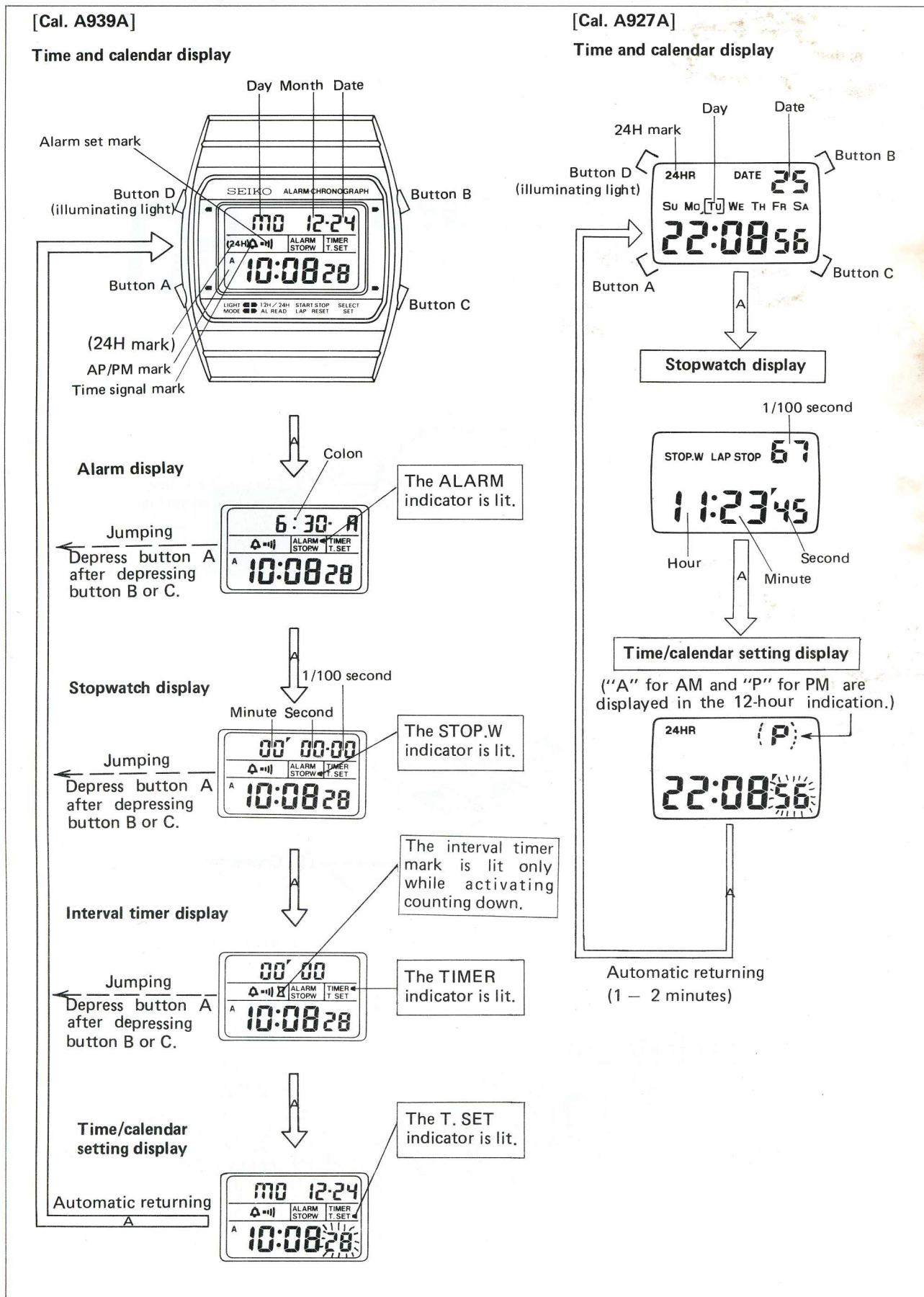

IV. DISASSEMBLING, REASSEMBLING AND LUBRICATING

Disassembling procedures Figs. : ① → ⑫

Reassembling procedures Figs. : ⑫ → ①

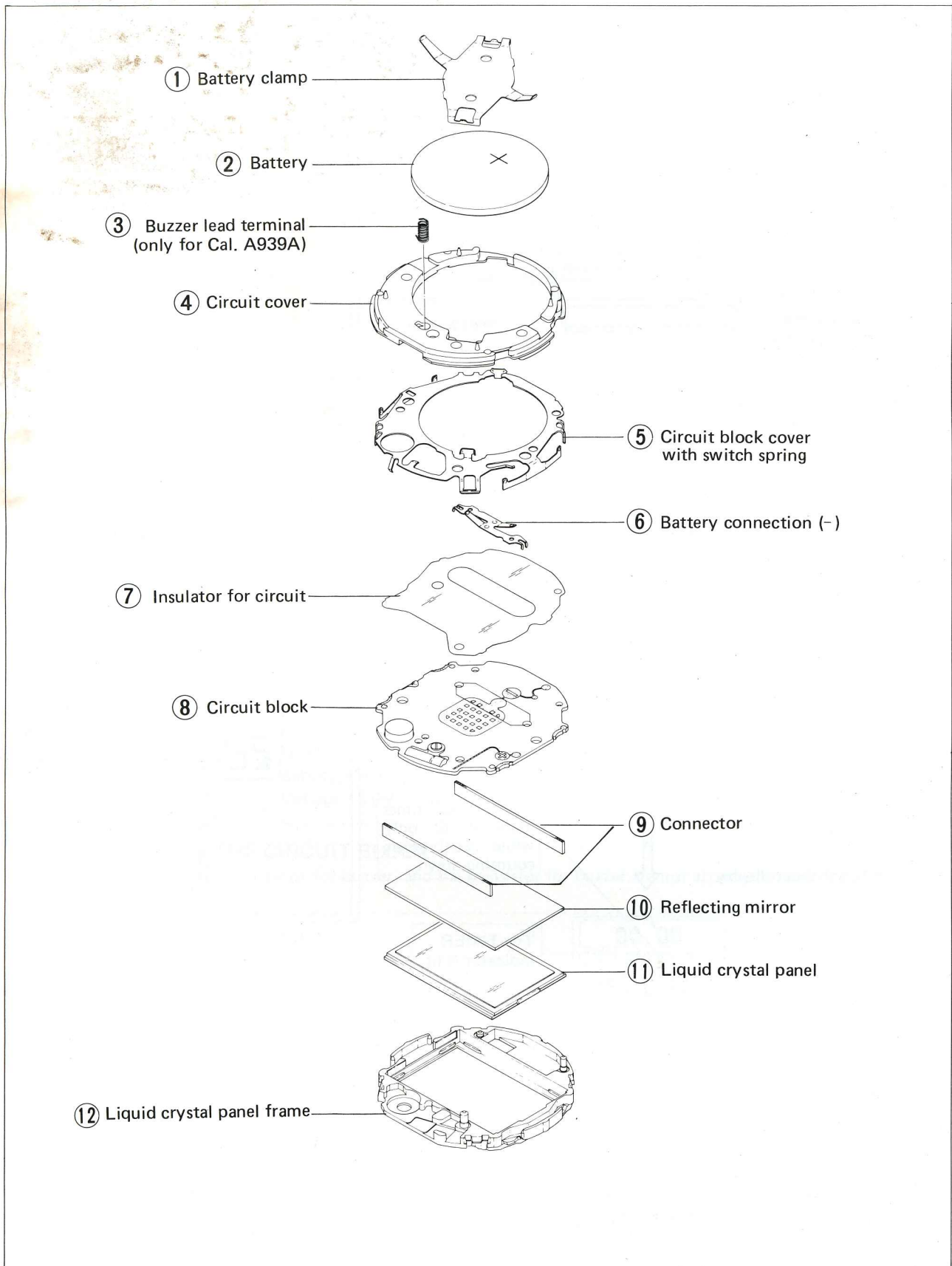

● Relationship between the segment (Liquid Crystal Panel Electrode) and the C-MOS-LSI output terminal

A complete knowledge of how the segment (Liquid Crystal Panel Electrode) works with the C-MOS-LSI output terminal will ensure the proper procedures for checking and adjustment.

● Designation of segment

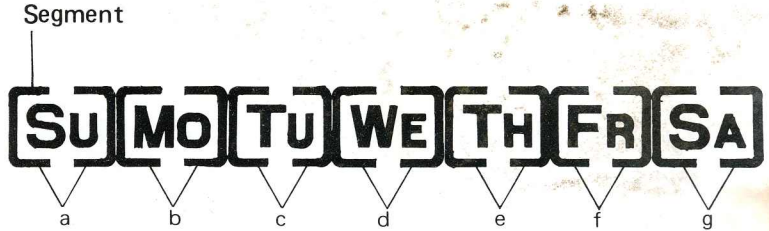
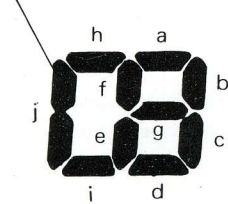

Cal. A939A

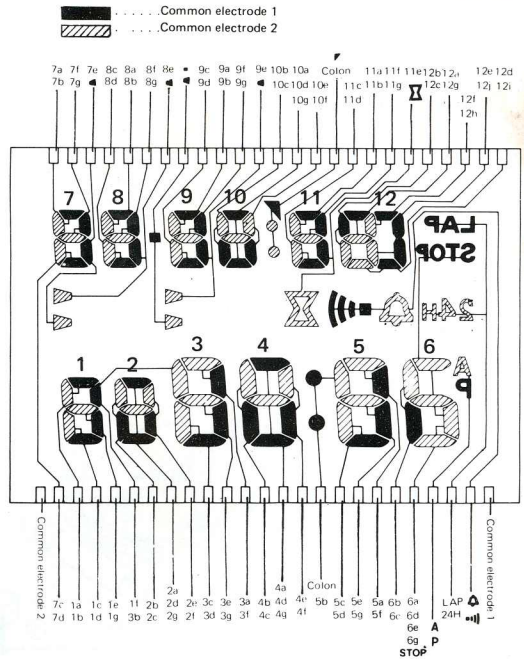
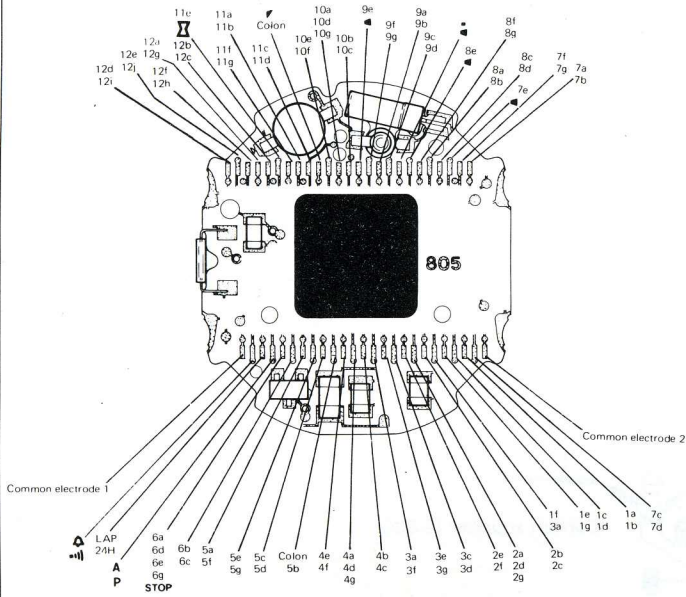

Cal A927A

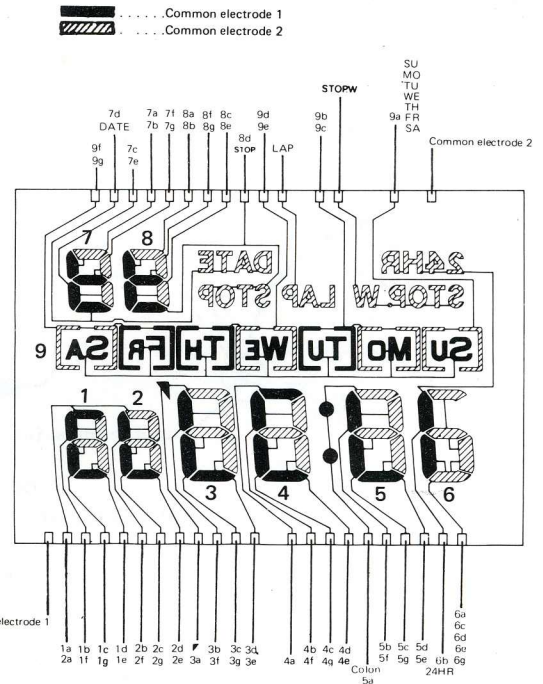
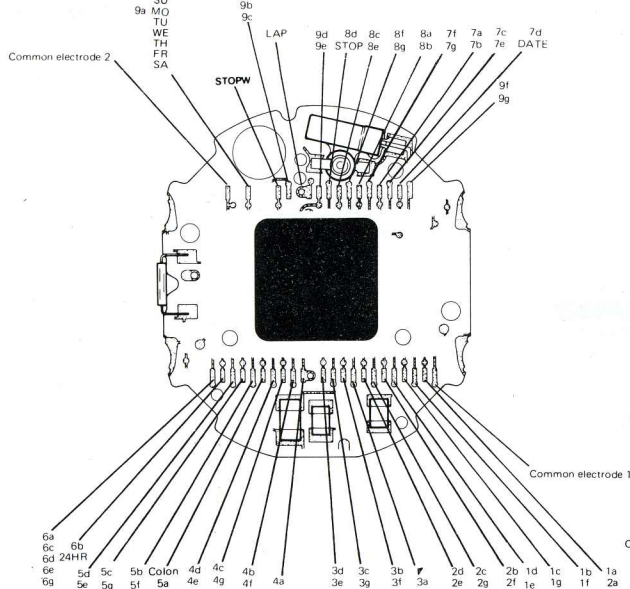

V. CHECKING AND ADJUSTMENT

- Refer to the "SEIKO QUARTZ TECHNICAL GUIDE, GENERAL INSTRUCTION" for digital watches for details.

Procedures

CHECK BATTERY VOLTAGE

Result:

More than 2.8V: Normal
 Less than 2.8V: Defective
 Replace the battery with a new one.

CHECK BATTERY CONDUCTIVITY

CHECK CURRENT CONSUMPTION

- Current consumption for the whole of the module

Result:

Less than $1.7\mu\text{A}$: Normal
 More than $1.7\mu\text{A}$: Defective

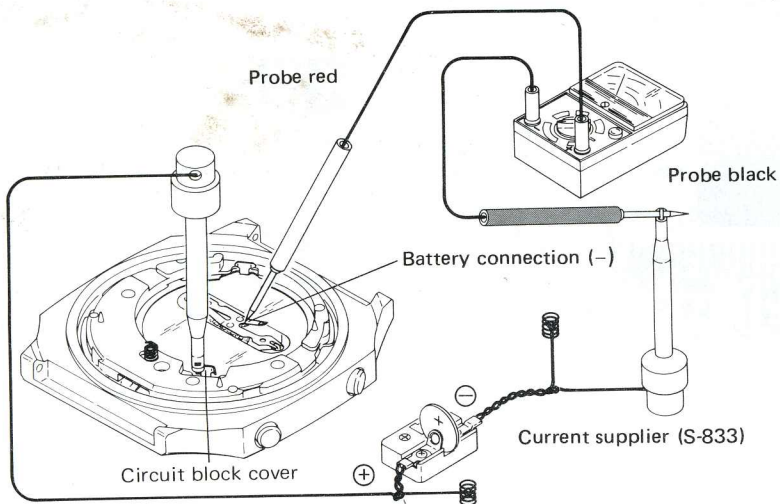

- Current consumption for the circuit block alone

Be careful to avoid short circuit with other terminals when clamping this part with a clip or the like.

Result:

Less than $1.5\mu\text{A}$: Normal
 Replace the liquid crystal panel with a new one.
 More than $1.5\mu\text{A}$: Defective
 Replace the circuit block with a new one.

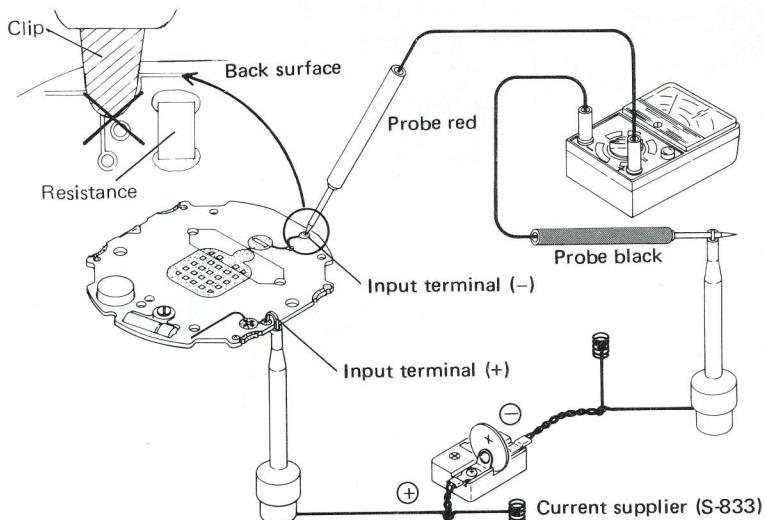

Procedures

CHECK WATER RESISTANCE

CHECK CONTACT BETWEEN C-MOS-LSI AND LIQUID CRYSTAL PANEL

CHECK LIQUID CRYSTAL PANEL AND CIRCUIT BLOCK

- Check the liquid crystal panel.
- Check the circuit block output voltage.

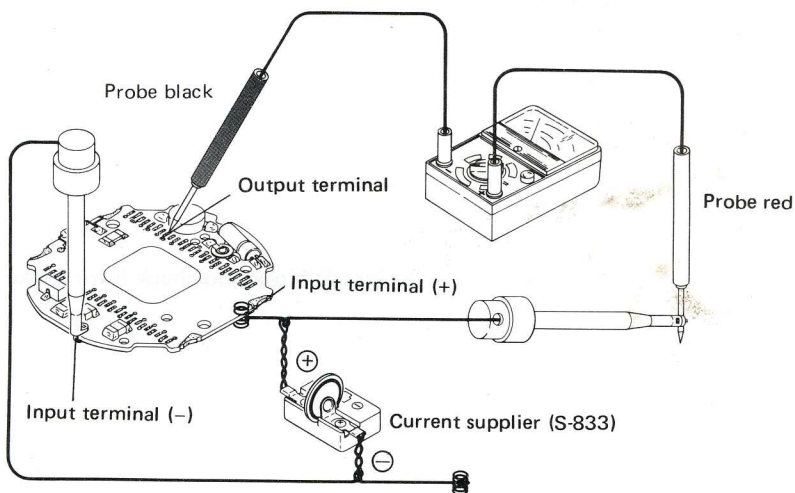

CHECK ACCURACY

Check the watch for accuracy in the daily rate measuring function with all the segments displayed.

Set the mode for the time and calendar setting function, then depress buttons B and C at the same time, and all the segments light up.



CHECK FUNCTIONING AND ADJUSTMENT

CHECK ALARM TEST SYSTEM (Only for Cal. A939A)

Depress buttons B and C at once in the time and calendar function.

(This operation also engages or disengages the time signal, and the time signal mark is displayed or extinguished.)

CHECK CONDUCTIVITY OF SWITCH COMPONENTS

Procedures

CHECK ALARM CONDITON (Only for Cal. A939A)

- (1) Check to see if there is any contamination on the connecting portion of the piezoelectric element on the inside surface of the case back and the buzzer lead terminal. Also, check to see if there is seen a deformation on the buzzer lead terminal.

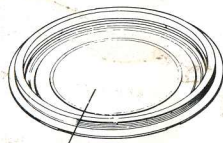

Piezoelectric element

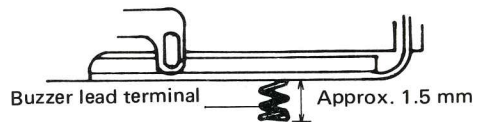

Buzzer lead terminal

Approx. 1.5 mm

- (2) Measure the resistance for the upconverter coil of the circuit block and check it for broken wire and short circuit.

Range to be used: **OHMS R x 1**

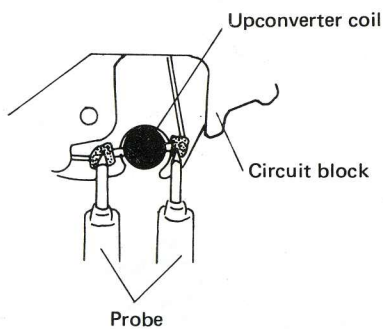

Upconverter coil

Circuit block

Probe

Result:

$20\Omega \sim 35\Omega$: Normal

Less than 20Ω

(Short circuit)

More than 35Ω

(Broken wire)

Defective

Replace the circuit block with a new one.

Apply the probes of the Volt-ohm-meter to the soldering portion of the upconverter coil terminal.

CHECK BULB CONDITION

For replacing the bulb, refer to the Technical Information No. 18.

CHECK FUNCTIONING

All procedures of Disassembling, Reassembling, Checking and Adjustment are completed.