

SEIKO

DIGITAL QUARTZ

Cal. S1 Series

Manualslib.com

(S111)
S111A
S119A
SP11

**PARTS
CATALOGUE**

Cal. S1 Series (S101A, S111A, S119A)

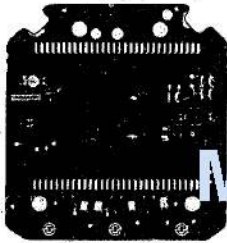
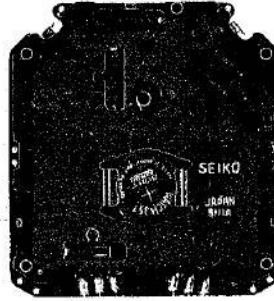

4001 825



4225 820



4246 825



4246 826



4270 825



4293 825



4313 825



4313 826

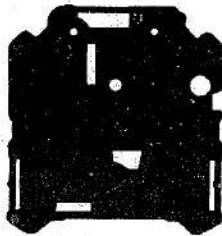

4410 825



4450 825

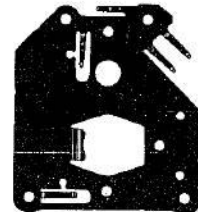

4457 825



4510 852

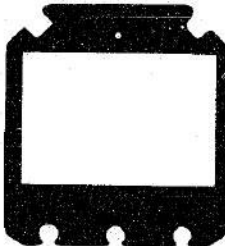

4512 825



7504 505



7504 509



☆ SONY EVEREADY 357



022 904



022 905

3/4

Cal. S1 Series (S101A, S111A, S119A)

Characteristics

Cal.	S101A	S111A	S119A
Casing diameter	46.7 × 43.0 mm		
Maximum height	10.2 mm without battery		
Frequency of quartz crystal oscillator	32,768 Hz (Hz=Hertz Cycles per second)		
Regulation system	Trimmer condenser		
Additional mechanism	Time and calendar function		
	Stopwatch function		
	Memory function		
	Print out function		

PART NO.	PART NAME	PART NO.	PART NAME
4001 825	Circuit block (Cal. S111)		
4001 826	Circuit block (Cal. S101)		
4001 827	Circuit block (Cal. S119)		
4225 820	Battery clamp (Cal. S111)		
4225 822	Battery clamp (Cal. S101)		
4225 824	Battery clamp (Cal. S119)		
4246 825	Buzzer lead terminal		
4246 826	Terminal for reset connection		
4270 825	Battery connection (-)		
4293 825	Switch lever (upper)		
4313 825	Connector		
4313 826	Switch connector		
4410 825	Circuit cover		
4450 825	Switch lever		
4457 825	Circuit block cover		
4510 852	Liquid crystal panel (Cal. S111)		
4510 853	Liquid crystal panel (Cal. S101)		
4510 854	Liquid crystal panel (Cal. S119)		
4512 825	Liquid crystal panel frame		
7504 505	Plug for stopwatch (Cal. S111, S119)		
7504 509	Plug cap (Cal. S111, S119)		
022 904	Circuit block cover screw		
022 905	Battery clamp screw		
☆SONY EVEREADY 357 ☆U.C.C. 357	Silver oxide battery		

Remarks :

Battery

☆SONY EVEREADY 357 } The substitutive battery might be added to the applied battery in the future.
 ☆U.C.C. 357 } In that case, please refer to "BATTERY LIST FOR SEIKO QUARTZ WATCHES".

☆□ Please see remarks

Part numbers in light letters are not shown in photos.

TECHNICAL GUIDE

SEIKO DIGITAL QUARTZ

CAL. S101A
CAL. S111A
CAL. S119A



CONTENTS

STOPWATCH

I. SPECIFICATIONS	1
II. STRUCTURE OF THE CIRCUIT BLOCK	1
III. DESIGNATION AND OPERATION	2
IV. DISASSEMBLING, REASSEMBLING, AND LUBRICATING OF THE CASE	3
1. Cal. S111A and S119A	3
2. Cal. S101A	4
V. DISASSEMBLING, REASSEMBLING, AND LUBRICATING OF THE MODULE	5
VI. RELATIONSHIP BETWEEN THE SEGMENT (LIQUID CRYSTAL PANEL ELECTRODE) AND THE C-MOS-LSI OUTPUT TERMINAL	6
VII. CHECKING AND ADJUSTMENT	7
• Check battery voltage	7
• Check current consumption	8
• Check liquid crystal panel and circuit block	9
• Check functioning and adjustment	9
• Check water resistance	10
• Check all the segments lit up	10

PRINTER

VIII. SPECIFICATIONS	11
IX. STRUCTURE OF THE CIRCUIT BLOCK	11
X. LIST OF THE SCREWS USED	12
XI. DISASSEMBLING AND REASSEMBLING OF THE SYSTEM PRINTER SP11	12
1. Roll paper setting block	12
2. Battery hatch - Holder	13
3. Printer unit - Front cover	14
XII. CORD	15

I. SPECIFICATIONS

Item	Cal. No.	S111A	S119A	S101A
Display medium		Nematic Liquid Crystal, FEM (Field Effect Mode)		
Liquid crystal driving system		Multiplex driving system		
Display system				
Time and calendar function		24-hour indication		
Memory function		8 measurement data		6 measurement data
Frequency measuring function		-		10 strokes/min, ~ 180 strokes/min.
Stopwatch function		Hours, minutes, seconds, and 1/100 second up to 10 hours.	Decimal notation Up to 100,000 DM in 0.1 DM	Hours, minutes, seconds, and 1/100 second up to 10 hours.
Additional mechanism		<ul style="list-style-type: none"> Automatic calendar display system (1980 - 2019) Time and calendar setting function All segment light up system Auto turn system Alarm sound (Only when the watch is connected to the system printer SP11.) 		
Loss/gain		Monthly rate at normal temperature range: less than 15 seconds		
Module size	Outside diameter	46.7 mm between 6 o'clock and 12 o'clock sides 43.0 mm between 3 o'clock and 9 o'clock sides		
	Height	10.2 mm		
Regulation system		Trimmer condenser		
Measuring gate by quartz tester		Any gate can be used.		
Battery		Maxell SR44W, U.C.C. 357, SONY EVEREADY 357 Battery life is approximately 3 years. Voltage: 1.56V		
Printer to be connected		SP11 - Connectable		-

II. STRUCTURE OF THE CIRCUIT BLOCK

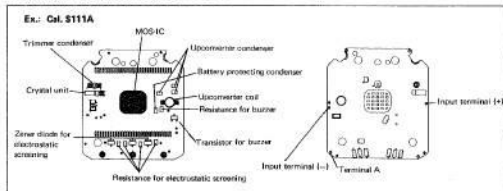

Note: The resistance for electrostatic screening and the Zener diode for electrostatic screening are not provided in Cal. S101A.

III. DESIGNATION AND OPERATION

[Cal. S111A, S119A]

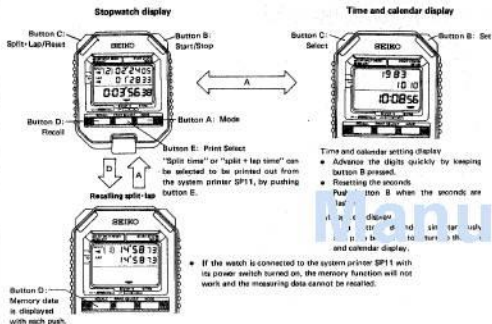

[Cal. S101A]

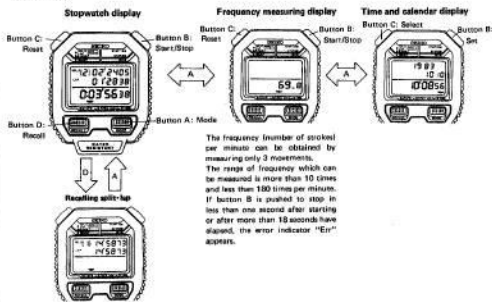

IV. DISASSEMBLING, REASSEMBLING, AND LUBRICATING OF THE CASE

1. Cal. S111A and S119A

Disassembling procedures: Figs. ① → ⑤
Reassembling procedures: Figs. ⑤ → ①

Lubricating: ● Silicone grease 500,000 c.s.
Normal quantity

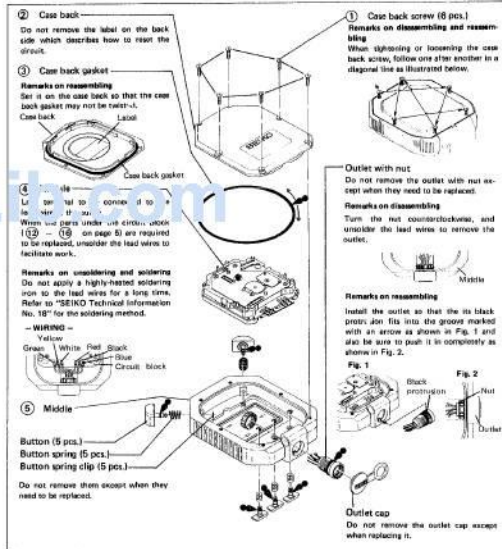

2. Cal. S101A

Disassembling procedures Figs.: ① → ④
 Reassembling procedures Figs.: ④ → ①

Lubricating: ● Silicone grease 500,000 c.s.
 Normal quantity

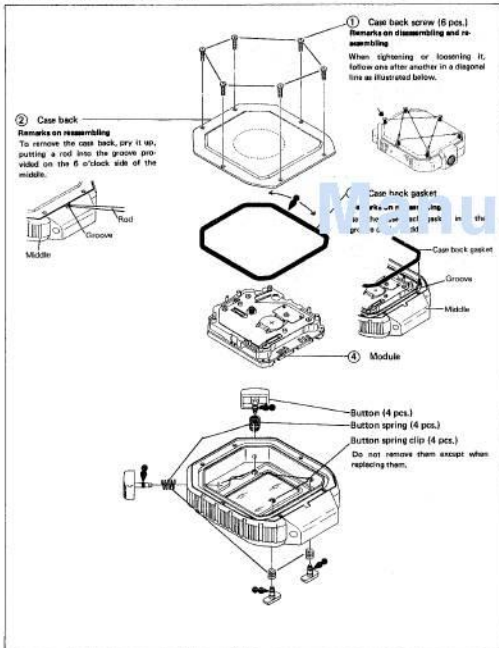

V. DISASSEMBLING, REASSEMBLING, AND LUBRICATING OF THE MODULE

• List of the screws used

Shape	Part No.	Name	Shape	Part No.	Name
	022 904	Circuit block cover screw (4 pcs.)		022 905	Battery clamp screw (1 pc.)

Disassembling procedures Figs.: ① → ⑱
 Reassembling procedures Figs.: ⑱ → ①

Lubricating: ● SEIKO Watch Oil S-6
 Normal quantity

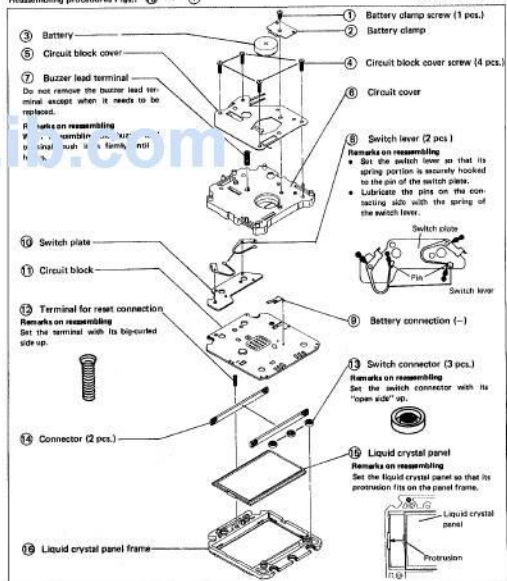

VI. RELATIONSHIP BETWEEN THE SEGMENT (LIQUID CRYSTAL PANEL ELECTRODE) AND THE C-MOS-LSI OUTPUT TERMINAL

• Designation of the segment

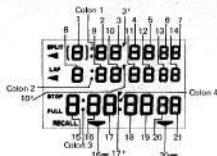

• Relationship between the segment and the C-MOS-LSI output terminal

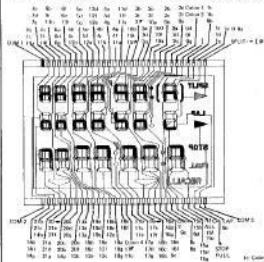

How to identify the circuit blocks for Cal. S101A, S111A, and S119A

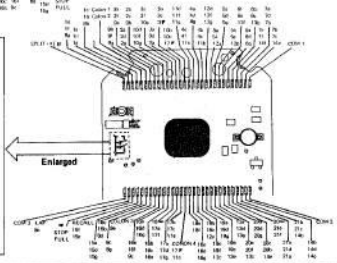
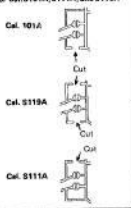

VII. CHECKING AND ADJUSTMENT

- The explanation here is only for the particular points of Cal. S101A, S111A, and S119A. Refer to the "TECHNICAL GUIDE, GENERAL INSTRUCTION" for SEIKO Digital Quartz for details.

Procedure

Remarks on replacing the battery

When installing the battery, be sure to reset the circuit to display as shown in the illustration by conducting either way as follows:

— Watch complete —

Push all the buttons at the same time continuously for 2 to 3 seconds.

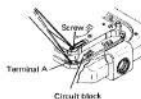
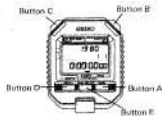

Note —

When the display shows "000000" in the illustration,

CHECK BATTERY VOLTAGE

Use the Digital Multi Tester S 841.

Range to be used: DCV

Result: More than 1.55V
Normal: Less than 1.55V
Defective: Less than 1.55V

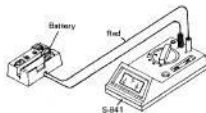

Procedure

CHECK CURRENT CONSUMPTION

1. Current consumption for the whole of the module

Range to be used: DCuA

(S-841: DCµmA)

After setting as shown in Fig. 1, reset the circuit as shown in Fig. 2.

Fig. 1

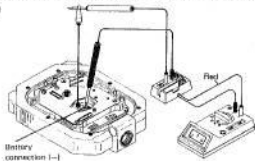
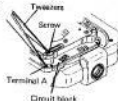

Fig. 2



Result:
Normal: Less than 6.2µA
Defective: More than 6.2µA

2. Current consumption for the circuit block alone

After setting as shown in Fig. 1, reset the circuit as shown in Fig. 2.

Fig. 1

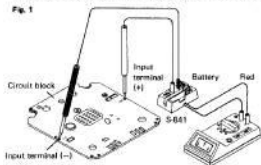
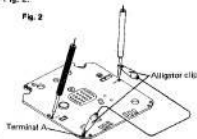

Fig. 2



Result:
Normal: Less than 5.0µA
Defective: More than 5.0µA

CHECK LIQUID CRYSTAL PANEL AND CIRCUIT BLOCK

Range to be used: DCV (S-841: DC V)

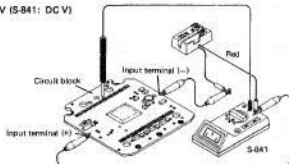

Procedure

CHECK FUNCTIONING AND ADJUSTMENT

Cal. S111A and S119A

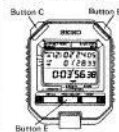

1. Check the memory function.

- ① Push button B (start) in the stopwatch function.
- ② Push button C (split-lap) 8 times in case of Cal. S111A and S119A and 6 times in case of Cal. 101A, and then push button B (stop).
- ③ Push button E (recall) to see whether the memory data can be recalled up to as many as 8 times in case of Cal. S111A and S119A and 6 times in case of Cal. S101A.

Note:

If the stopwatch is connected to the system printer SP11 with its power switch turned on, the memory function will not work. Be sure to disconnect the printer or turn off its power switch.

Result:

Normal: The memory can be recalled.
Defective: The memory cannot be recalled.
Reset the circuit by pushing all buttons simultaneously and check the memory function.
In case the memory function does not still work correctly, replace the circuit block with a new one.

2. Check the system printer functioning.

(In case the system printer SP11 is used with Cal. S111A and S119A)

If the system printer does not function normally, go through the following procedures.

Fig. 1

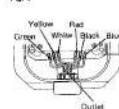

a) Watch module

- Check to see that the six lead wires are correctly soldered to the lead terminal of the circuit block in the right order as shown in Fig. 1.
- Check to see that the lead wires to be connected with the outlet are properly soldered (Fig. 1).
- Check to see that the adjoining soldered parts touch to cause a short circuit (Fig. 2).

Result:

Each lead wire is correctly soldered.
Proceed to procedure b).
A lead wire is not soldered correctly.
Solder it again.

b) System printer (SP11)

Check the system printer's battery voltage.

Result:

Normal: More than 1.55V for each piece
Defective: Less than 1.55V for each piece.
Replace the batteries with new ones.

Fig. 2

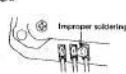

Procedure

Cal. S101A

Button C
Reset

Button B
Start/Stop



Check to see if the frequency measuring function is correctly activated.

- ① Push button B to see if the start and stop are correctly made.
- ② Check to see if "190.0" flashes for approximately 1 second just after button B is pressed to start measuring, and if "Err" is shown by pressing button B while "190.0" is still flashing.
- ③ Check to see if "Err" is shown after a lapse of 10.0 seconds from the start when no operation is made in the time.

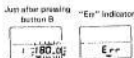

CHECK WATER RESISTANCE (only for Cal. S101A)

- Use the Air-pressure Water Resistance Tester S-451.

CHECK ALL THE SEGMENTS LIT UP

- Push buttons B and C at the same time in the time and calendar setting function.
- The display returns to the time and calendar display by pushing button A.

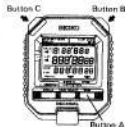



I. SPECIFICATIONS

Item	Cal. No.	System printer CP11
Printing system		Thermal type serial dot
Printing function		13 digits/line (including space) Numerals, alphabets, +, -, x, ÷, %, 1/2, 1/3, 1/4, 1/5, / Printing speed is approximately 0.7 line/second.
Outside diameter		126.0 (H) x 75.0 (W) x 23.4 (T) mm
Battery		IEC Designation R6 or LR-6 (size AA) battery, 3 pcs.
Battery voltage		1.5V
Battery life		R-6 battery: Approx. 3,000 lines (Approx. 4 rolls) LR-6 battery: Approx. 6,000 lines (Approx. 8 rolls) (When the printer is connected with the Stopwatch Cal. S111A or S119A and used at 24°C)
ap (roll aper)	76 mm (aper)	Diameter of roll: φ18 mm Max.

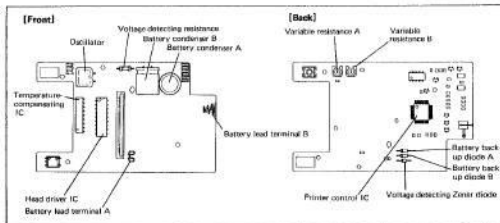
II. STRUCTURE OF THE CIRCUIT BLOCK



III. LIST OF THE SCREWS USED

Shape	Part No.	Name	Shape	Part No.	Name
	8150 1083	Screw A (3 pcs.) (for back cover)		8150 2003	Screw B (1 pc.) (for battery compartment)
				8150 2022	Screw C (1 pc.) (for circuit block)

IV. DISASSEMBLING AND REASSEMBLING OF THE SYSTEM PRINTER SP11

1. Roll paper setting block

Disassembling procedures Figs.: ① → ③
 Reassembling procedures Figs.: ③ → ①

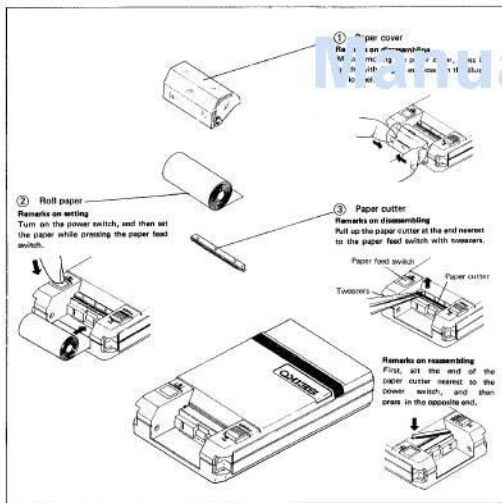

2. Battery hatch - Holder

Disassembling procedures Figs.: ① → ④
 Reassembling procedures Figs.: ④ → ①

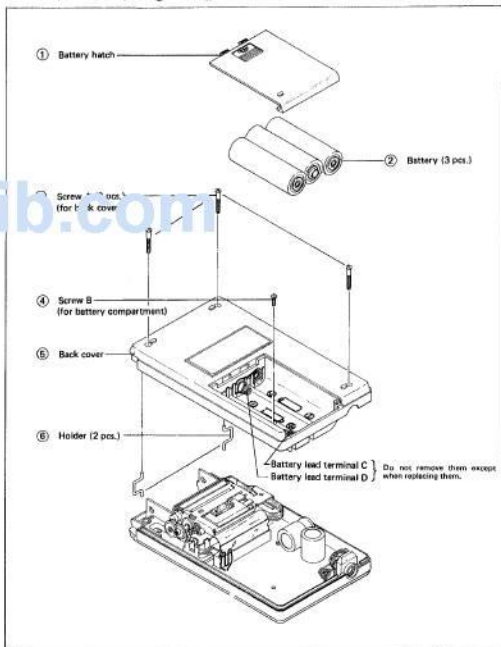

3. Printer unit ~ Front cover

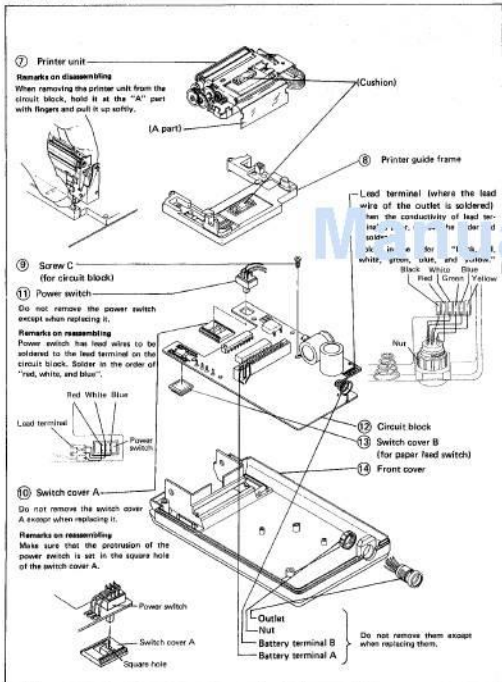

V. CORD

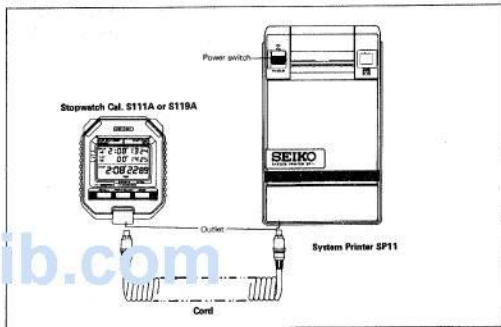

How to connect the cord

Holding the cord with fingers as designated in the illustration on the right, insert its plug into the outlet of the stopwatch and that of the printer respectively until they click fixed. The guide groove is provided on the plugs of the cord, and it should be inserted in position.

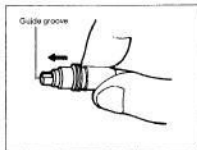

How to take off the cord

After use, turn off the printer's power switch and then unplug the cord from the watch and the printer, holding it with fingers as designated in the illustration on the right.

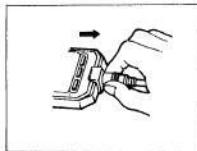

• Guide table for checking and adjustment of printer

Printer's defective symptom

Checking procedures

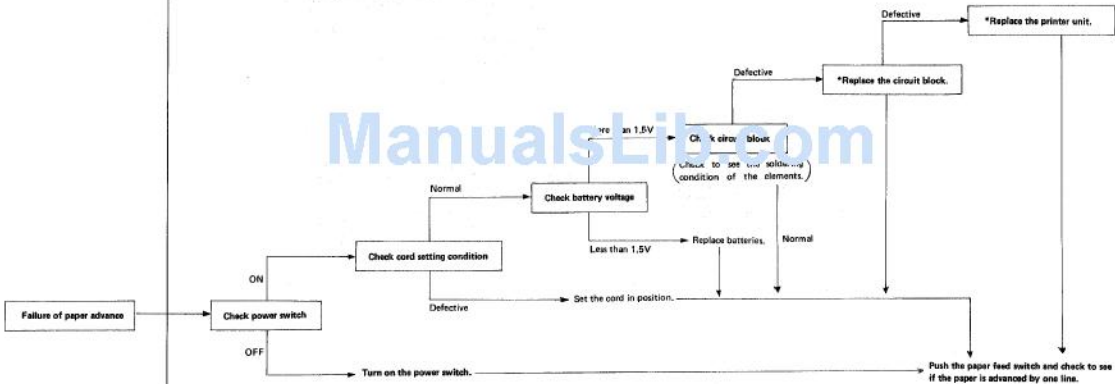

*Printing density adjustment is required after replacing the circuit block and/or the printer unit. Refer to page 18 for details.

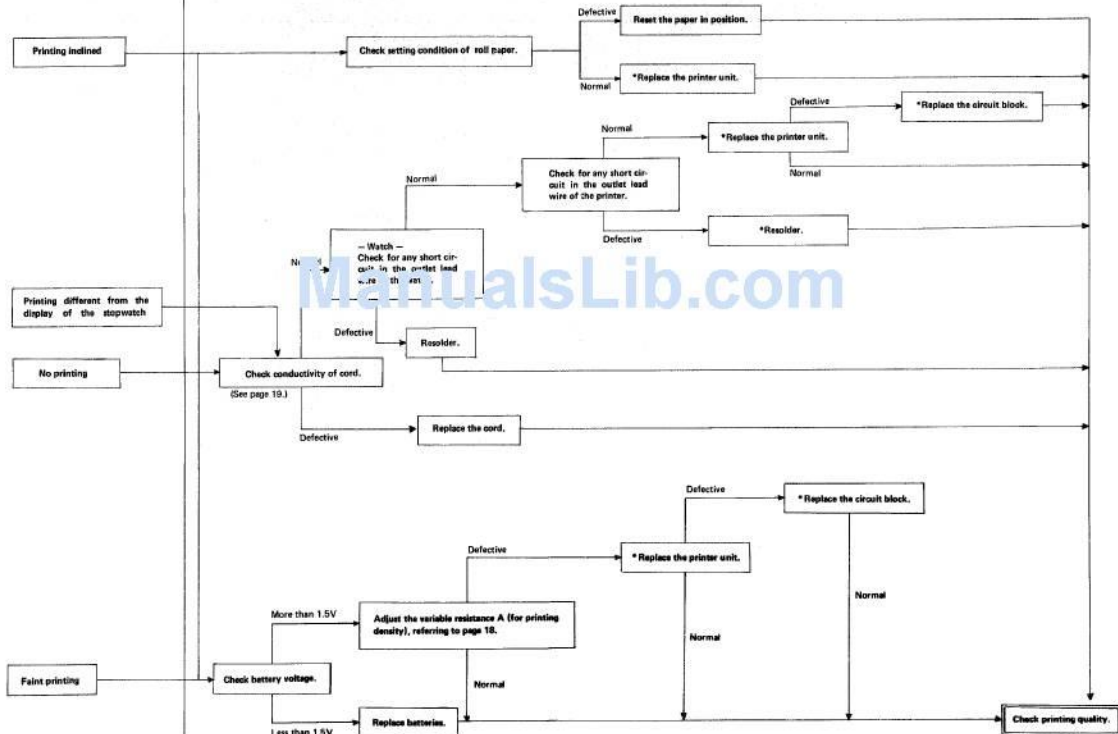

HOW TO ADJUST THE PRINTING DENSITY

1. Turn the variable resistance A on the circuit block with a screwdriver and adjust the printing density.

To make dense: Clockwise
To make light: Counterclockwise

2. Check the printing density again after reassembling.
If the density of the letters is adjusted to too dark, it will cause the printer to consume excess current.

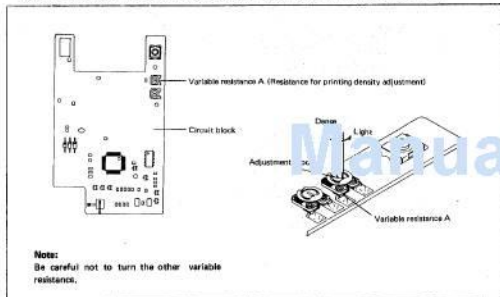

• In case of adjustment after replacing the printer unit only.

Printer unit shows A, B, C or D on its "A part" described in the illustration on page 14 to identify the degree of printing density. And the printing density becomes heavy in the order of A, B, C and D. Adjustment is not required when the degree of the old and the new printer units are same or near to each other.

• In case of adjustment after replacing the circuit block only.

Set the adjustment groove of the variable resistance A in the same position as that of the old circuit block.

HOW TO CHECK CONDUCTIVITY OF THE CORD

Insert metal rods or thick wires in the corresponding holes of the plugs at both ends of cord and apply the probes of the tester to the metal rods.

