

# ***TECHNICAL INFORMATION***

---

**Manualstjib.com**  
**CITIZEN QUARTZ**

**Cal. No. C4⌘⌘**

## Contents

<b>§1. OUTLINE</b> .....	1
EL (Electroluminescence) Illumination.....	1
<b>§2. SPECIFICATIONS</b> .....	2
<b>§3. NAME OF PARTS</b> .....	3
<b>§4. SETTING THE ANALOG TIME</b> .....	4
COMMON TO CAL. C400, C401, C410, C420 AND C430.....	4
<b>§5. HANDLING OF DIGITAL DISPLAY SECTION</b> .....	4
5-1. Switching Functions (Modes).....	4
5-2. Adjusting the Digital Time .....	7
5-3. Adjusting the Calendar.....	11
5-4. Using the Alarm .....	13
5-5. Using the Chronograph.....	15
5-6. Using the Timer.....	21
5-7. Using the Local Time Mode .....	24
5-8. Using the Zone Set.....	24
5-9. Monitoring the UTC (Greenwich time) .....	25
<b>§6. ALL-RESET FUNCTION</b> .....	25
<b>§7. DISASSEMBLY AND ASSEMBLY OF MODULE</b> .....	26
<b>§8. TROUBLESHOOTING AND ADJUSTMENT</b> .....	27

ManualsLib.com

# §1. OUTLINE

## • CAL. C400 (Super Chronograph Magic Light)



- Time Mode
- Calendar Mode
- Alarm Mode
- Chronograph Mode
- Race Chronograph Mode
- Timer Mode
- EL Illumination

## • CAL. C401 (Racing Combo Magic Light)



- Time Mode
- Calendar Mode
- Alarm Mode
- Chronograph Mode
- Race Chronograph Mode
- Timer Mode
- EL Illumination

## • CAL. C410 (Combo Diver Magic Light)



- Time Mode
- Calendar Mode
- Alarm Mode
- Chronograph Mode
- Timer Mode
- EL Illumination

## • CAL. C420 (Wingman V)



- Time Mode
- Calendar Mode
- Alarm Mode 1 & 2
- Chronograph Mode
- Timer Mode
- Zone Setting Mode
- UTC Monitor
- EL Illumination

## • CAL. C430 (Mountain Bike Magic Light)



- Time Mode
- Calendar Mode
- Alarm Mode
- Chronograph Mode
- Chrono Memo Mode
- Timer Mode
- Pace Timer Mode
- Local Time Mode
- EL Illumination

## ■EL (Electroluminescence) ILLUMINATION

### EL

EL (Electroluminescence) panel is a fluorescent panel which becomes illuminant when voltage is applied to it.

### EL Illumination

The EL panel will be illuminated under the following circumstance.

Mode	CAL/Button				
	C400, C401 A Button	C410 B Button	C420 A Button	C430 C Button	
Time	○	○	○	○	
Calendar	○	○	○	○	
Chronograph					
• Split time state	○	○	○	○	
• Stop state	○	○	○	○	
Race Chronograph					
• Lap time state	○				
• Stop state	○				
Chronograph Mode					
• Split/lap time state				○	
• Stop state				○	
Zone Set			○		
UTC			○		

## §2. SPECIFICATIONS

Caliber No.	C400	C401	C410	C420	C430	
Type	Combination quartz watch					
Module size	30.8ø × 5.21t					
Accuracy	±20 Sec./month					
Oscillation	32.768Hz					
Display method	FE nematic LC display & analog display					
Integrated circuit	C/MOS-LSI 1 unit					
Operating temperature range	0°C ~ 55°C (32°F ~ 131°F)					
Converter	Bipolar step motor					
Adjustment of time rate	Not installed					
Measurement of time rate	2 seconds					
Display function	Analog time	Hour, minute, second				
	Digital	Time	AM/PM	AM/PM (Mark)	AM/PM	AM/PM City name
		Calendar	Year, month, date, day		Month, date, day	
	Alarm 1	Set time ON/OFF	Set time ON/OFF	Set time ON/OFF	Set time ON/OFF City name	Set time ON/OFF
	Alarm2				Set time ON/OFF City name	
	Timer	60 minutes timer (1 minute decrements)		24 hour timer (1 minute decrements)		
	Pace timer					Pace timer; 24-hour Pace set; 60~180 beats per minute
	Chronograph	24-hour timer (1/1000 second increments)		(1/100 second increments)	(1/1000 second increments)	100-hour timer (1/100 second increments)
		Split time				
	Race chronograph	24-hour timer (1/1000 second increments) Lap time, Memo function				
	Chronograph memo					100-hour timer. (1/100 second increments). ● Split chrono. ● Lap chrono
	Local time					Hour, minute, L-mark
	Zone set				City name Ordinary time	
	UTC monitor				Coordinated universal time	
	Battery	Parts No./Battery code	280-44 (SR927W)			
Nominal voltage		1.55V				
Nominal capacity		60mAh				
Lifetime		Approx. 2 years				

# §3. NAME OF PARTS

[CAL. C400]



[CAL. C401]

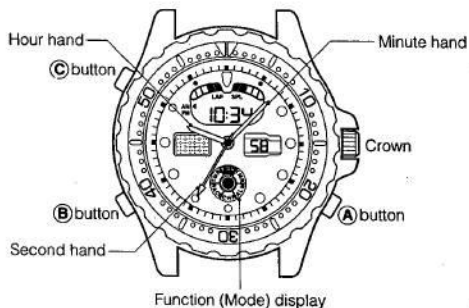

[CAL. C410]



[CAL. C420]

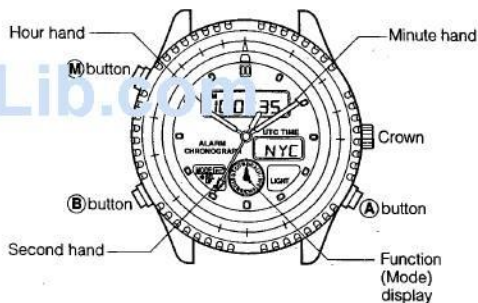

[CAL. C430]

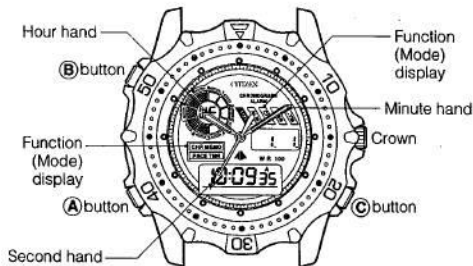

## §4. SETTING THE ANALOG TIME

☆ COMMON TO CAL. C400, C401, C410, C420 AND C430

1. Pull out the crown. The second hand will stop moving.
2. Turn the crown to set time.
3. Push the crown back to the normal position.

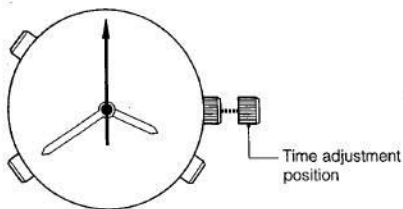

The analog time and the digital time can be adjusted separately, so you can use this watch as a dual time watch.

### How to adjust the watch to the correct time.

Stop the seconds hand at the "0" position. Move the minutes hand to a few minutes past the time you want to set, then move it back to the correct time. Press the crown back synchronizing to the correct time.

## §5. HANDLING OF DIGITAL DISPLAY SECTION

### 5-1. Switching Functions (Modes)

Switching Function for CAL. C400 and C401

- Other than the time, this watch has five functions: Calendar, Alarm, Chronograph, Race chronograph, and Timer.
- Each time you press button © the mode will change.

<CAL C400>

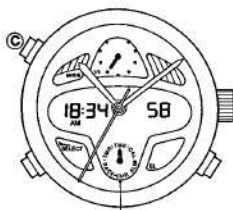

Function (Mode) display

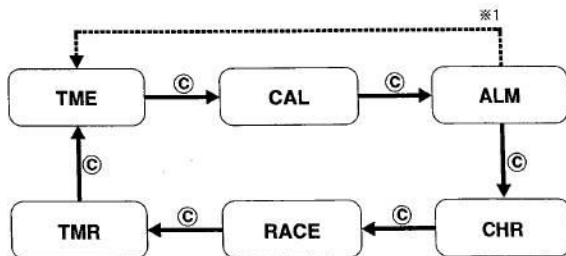

※1: If left in the alarm mode for more than 2 minutes, it will automatically return to time mode.

<CAL C401>

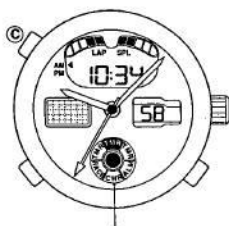

Function (Mode) display

## CAL. C400 Button Function Indication

- This watch has a digital display beside each of the three buttons which displays the next function for each button. See the display.

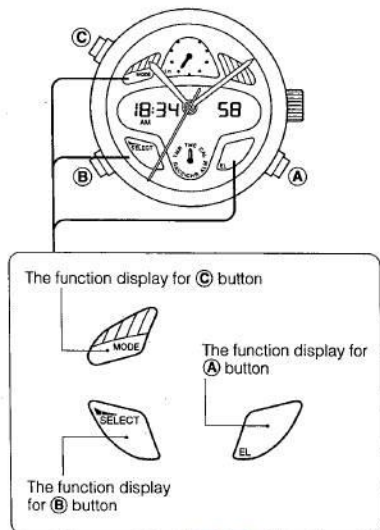

## Display and functions for each button

Button	Display	Function	The mode for each display
(C)	MODE	Switches modes.	Each mode.
		Returns to normal display manually while adjusting.	Each modes adjusting state.
(B)		Switches to the adjusting state by pressing for more than 2 seconds.	Time calendar mode.
	SELECT	Selects the digit you wish to adjust.	Each modes adjusting state.
	RESET	Reset.	Chronograph, timer stop state.
	RE	Timer restart function. (flayback)	While the timer is running.
	SPL	Split time display.	While the chronograph is running.
(A)	LAP	Lap time display.	While the race chronograph is running.
	CALL	Retrieve memo.	Race chronograph reset state.
	SET	Adjust.	Each modes adjusting state.
	START	Start.	Chronograph, timer reset state.
	STOP	Stop.	While using chronograph, timer.
	EL	Eliminate EL panel.	Time calendar mode.

## Switching Functions for CAL. C410

- Other than the time, this watch has four functions: Calendar, Alarm, Chronograph, and Timer. Each time you press (M) button the mode will change.
- \* The mode mark indicates the selected mode.

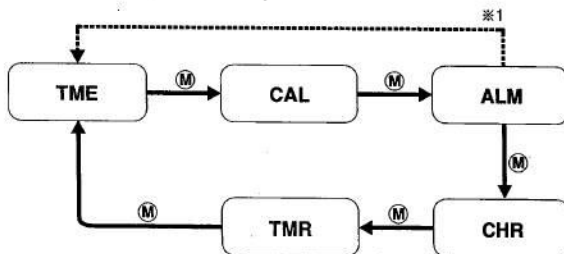
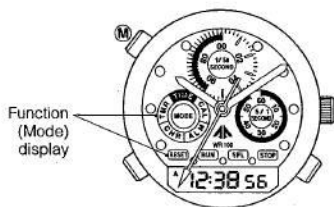

### Auto return

When in the position to set any of the modes, the watch will automatically return to the respective mode's normal display if there is no input for about 2 minutes.

### Manual return

Depress the (M) button in the any set mode for more than 2 seconds to manually return to the normal time mode.

※1: If left in the alarm mode for more than 2 minutes, it will automatically return to time mode.

## Switching Functions for CAL. C420

- Other than the time, this watch has seven functions: Calendar, Alarm 1 & 2, Chronograph, Timer, Zone set and UTC monitor. Each time you press the **M** button the mode will change.
  - \* The mode mark indicates the selected mode.



Function (Mode) display

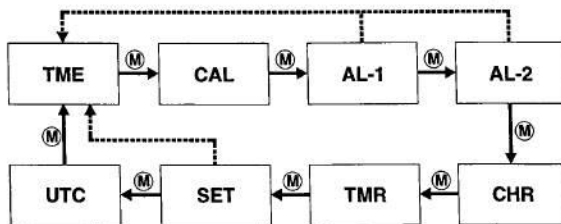

### Auto return

When in the position to set of Alarm 1, Alarm 2 or Zone set modes, the watch will automatically return to the respective mode's normal display if there is no input for about 2 minutes.

## CAL. C420 Button Function Indicator

This watch digitally indicates the function of each button.

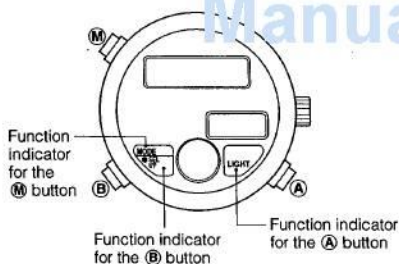

- Each function indicator for button operation appears on the display when a button is operated.

### Function Indicator for Button Operation

Button	Indication	Function	Operating Mode
<b>M</b>	MODE	Mode selection	In any mode
		Instant return to normal time display from the adjustment mode	In the adjustment mode of any display
<b>B</b>		Changes into adjustment mode after pressing the button 2 secs.	In the TME, CAL, AL-1/AL-2 or TMR mode
	SEL	Digit selection for adjustment	In the adjustment mode
	RESET	Reset the counter	In the stop state of CHR or TMR mode
	RE	Restart timer	In the TMR countdown state
	SPL	Split time indicated	In the CHR running state
	UP	Selecting the city name forward	In the TME, CAL, AL-1/AL-2 and SET modes
	DOWN	Selecting the city name backward	In the TME, CAL, AL-1/AL-2 and SET modes
<b>A</b>	SET	Adjustment of the flashing digit	In the adjustment mode
	START	Start the counter	In the reset state of the CHR or TMR mode
	STOP	Stop the counter	In the running state of the CHR or TMR mode
	LIGHT	EL illuminated	In the TME, CAL, SET and UTC modes

## Switching Functions for CAL. C430

- Other than the time/calendar, this watch has four functions: Alarm, Chronograph/Chrono memo, Timer/Pace time and Local time.
- Each time you press **(B)** button the mode will change.
- If the **(B)** button is pushed and held for about 2 seconds in the chronograph mode, the watch is set to the chronograph memo mode.
- If the **(B)** button is pushed and held for about 2 seconds in the timer mode. The watch is set to the pace timer mode.

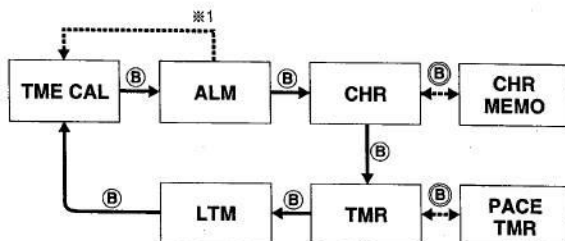
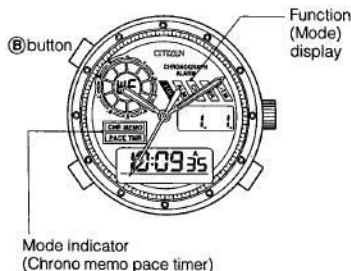

### • Auto return:

If, while the watch is in the setting mode, there no input for 2 minutes or mode, it will automatically returns to normal mode.

### • Quick return:

If at any point during setting **(B)** button is pressed, the display returns to normal mode (except in pace timer).

※ 1: This watch automatically returns to Time/Calendar Mode if left in Alarm Mode for more than 2 minutes.

## 5-2. Adjusting the Digital Time

### CAL. C400 and C401

#### <Normal Time Display>

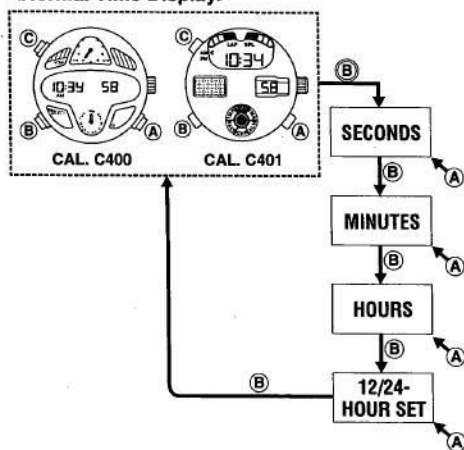

#### <Adjusting seconds>

1. In time mode, press the **(B)** button for more then 2 seconds, "second" will flash, and change to adjusting state.
2. While seconds flash, press and release the **(A)** button to reset the seconds to "00".

#### <Adjusting the time>

1. When in the seconds adjustment state (seconds flash), press the **(B)** button, the flashing digit will change in the order of seconds – minutes – hours – 12/24 hour system. Select the digit you wish to adjust.
2. Adjust the flashing digit by pressing the **(A)** button.
  - Press the **(A)** button, the 12 hour/24 hour will switch alternately.
  - If the time adjustment state (flashing digit) remains for longer than 2 minutes, the watch will automatically return to normal time display mode.
  - Press the **(C)** button while in the time adjustment state, you can return the watch to normal display mode. (Manual return)

## Adjusting the Time CAL. C410

### <Normal Time Display>

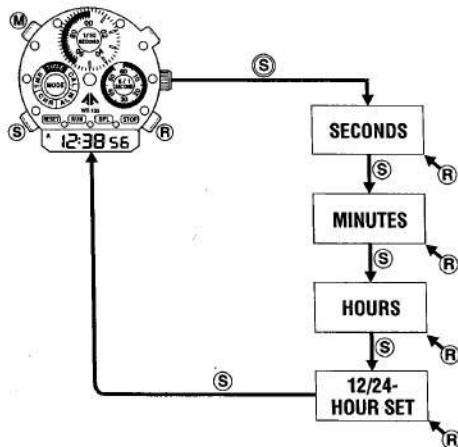

### <Adjusting seconds>

1. In time mode, press the **(S)** button for more than 2 seconds, "second" will flash, and change to adjusting state.
2. While seconds flash, press and release the **(R)** button to reset the seconds to "00".

### <Adjusting the time>

1. When in the seconds adjustment state (seconds flash), press the **(S)** button, the flashing digit will change in the order of seconds – minutes – hours – 12/24 hour system. Select the digit you wish to adjust.
2. Adjust the flashing digit by pressing the **(R)** button.
  - Press the **(R)** button, the 12 hour/24 hour will switch alternately.
  - If the time adjustment state (flashing digit) remains for longer than 2 minutes, the watch will automatically return to normal time display mode.
  - Press the **(M)** button while in the time adjustment state, you can return the watch to normal display mode. (Manual return)

## Adjusting the Time CAL. C420

When the Local Time adjustment for a city is completed, the time of other cities will be automatically adjusted calculating time differences.

### <Normal Time Display>

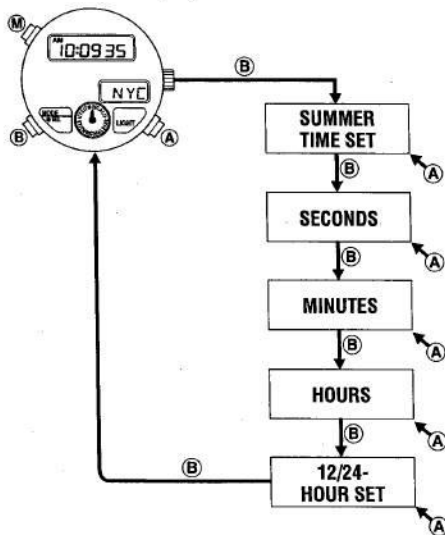

### <Adjusting Time>

- 1) Set to the Time mode by pressing the **(M)** button.
- 2) Press the **(B)** button to select the desired city name for adjustment.
- 3) The "ON" or "OFF" indicator of the Summertime set will start flashing by pressing the **(B)** button for about 2 seconds. Set the Summertime by pressing the **(A)** button while the indicator is flashing.
- 4) To adjust other Time displays, select the digits by pressing the **(B)** button. The flashing digits will change in the order as shown in the diagram.
- 5) Adjust the flashing digits by pressing the **(A)** button. Press and hold the **(A)** button for quick adjustment.
  - Make sure that the AM/PM indication is correct when setting the time to the 12-hour display system.
  - Auto-Return to the normal display will activate when the watch is left in the adjustment mode for more than 2 minutes.
  - The adjustment mode will be directly returned to the normal time display by pressing the **(M)** button.

### <What is the "Summertime">

It is also called DST (Daylight Saving Time). The Summertime system is in effect in some cities advancing the local standard time for certain hours to make a day time more useful during the summer season. (The Summertime set is achieved only by one hour adjustment on this watch.)

## Monitoring the Universal Local Time and the Calendar CAL. C420

- 1) Select the TIME or CALENDAR mode by pressing the **(M)** button.
- 2) Press the **(B)** button to monitor the Local time or calendar. One of the mods will be shown with the city name.

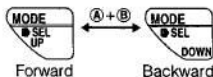
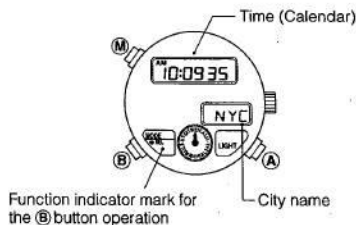

- The city name in the zone selection mode will advance forward by pressing the **(B)** button when the function indicator mark of the **(B)** button operation shows "UP". When the indicator mark shows "DOWN", the zone selection will change backward.
- Press the **(A)** and **(B)** button simultaneously to switch the "UP" and "DOWN" indicator marks.
- The cities adopting the summertime are indicated with a circle mark (○), the non adopting cities are indicated with a cross mark (×).
- The time difference between the UTC and the summertime shown in the table may some differ from the domestic summertime system adopted in each city.

### Time difference between the Local Time and the UTC as of 1989

NO.	Indication	City	Time difference	Summer time	NO.	Indication	City	Time difference	Summer time
1	UTC	Universal time coordinated	±0	—	17	TYO	Tokyo	+9	×
2	LON	London	±0	○	18	SYD	Sydney	+10	○
3	PAR	Paris	+1	○	19	MOU	Moscow	+11	×
4	ROM	Rome	+1	○	20	MKL	Mankato	+12	○
5	CAI	Cairo	+2	○	21	HNL	Honolulu	-10	×
6	IST	Istanbul	+2	○	22	ANC	Anchorage	-9	○
7	MOW	Moscow	+3	○	23	LAX	Los Angeles	-8	○
8	KWI	Kuwait	+3	×	24	DEN	Denver	-7	○
9	DXB	Dubai	+4	×	25	CHI	Chicago	-6	○
10	KHI	Karachi	+5	×	26	MEX	Mexico City	-6	×
11	DEL	New Delhi	+5.5	×	27	NYC	New York	-5	○
12	DAC	Dacca	+6	×	28	YUL	Montreal	-5	○
13	BKK	Bangkok	+7	×	29	CCS	Caracas	-4	×
14	SIN	Singapore	+8	×	30	RIO	Rio de Janeiro	-3	○
15	HKG	Hong Kong	+8	×	31	BUE	Buenos Aires	-3	×
16	PEK	Beijing	+8	×					

- **Graphic indication:** Time and calendar are indicated graphically in the second indication timing.

## <Normal Time Display>

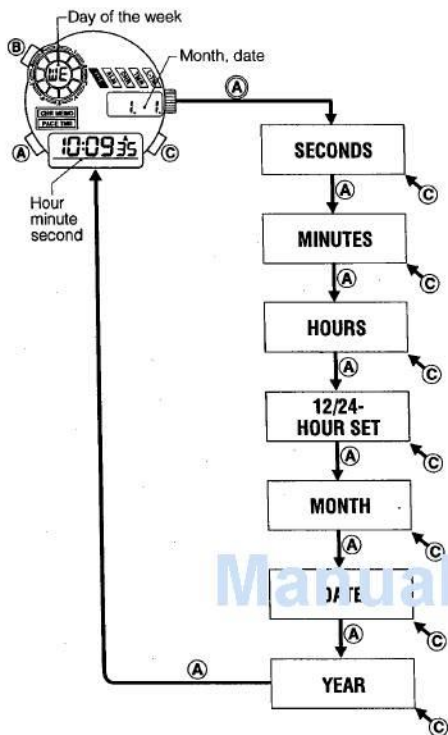

## <Adjustment of seconds>

- (1) When the **(A)** button is pressed for 2 seconds or more, the watch enters adjustment mode with the seconds flashing.
- (2) When the **(C)** button is pressed while the seconds are flashing, the seconds display is reset to "00".

## <Adjusting the time/calendar>

- (1) Each time the **(A)** button is pressed during the adjustment mode (when the seconds are flashing), the flashing display changes sequentially. Press the **(A)** button required number of times to reach the display to be adjusted.
- (2) Press the **(C)** button for each digit adjustment.
  - For the 12-hour display, note AM/PM.
  - Auto return: If the watch is left in the adjustment mode (while any display is flashing) for 2 minutes without operating any buttons, the auto-return system returns to the normal time display.
  - The calendar can be set from 1995 to 2080.
  - The day of the week is automatically set when the year, month and date are adjusted.
  - If a non-existent date (for example, February 30) is set during adjustment, the time/calendar display will show the 1st day of the next month when returned to the normal time/calendar mode.
  - Because the auto-calendar is used, no adjustment at the end of the month is needed.

This watch's normal mode digital time display (TME) is automatically coordinated with that of the local time mode display. Thus, the time in normal mode is adjusted, the time in local time mode will automatically adjust accordingly. (Month and date do not change.)

## 5-3. Adjusting the Calendar

### Adjusting the Calendar CAL. C400, C401

#### <Normal Calendar Display>

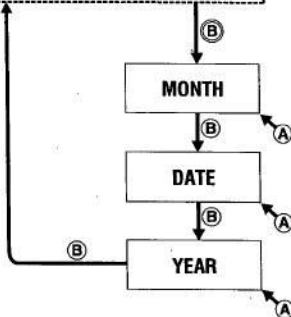
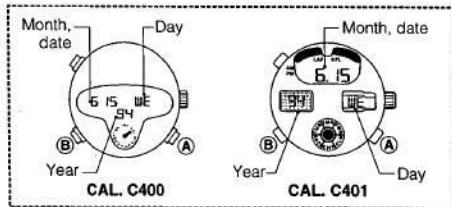

#### <Setting the Calendar>

- (1) Press the **(B)** button in the calendar mode for more than 2 seconds to enter the month adjustment mode.
- (2) Press the **(A)** button to adjust the month digits.
- (3) Press the **(B)** button in the month adjust mode to move to the next adjustment mode.
- (4) Press the **(A)** button to make adjustment. (Press the **(A)** button when setting the calendar to use the quick-advance feature.)

- Year can be set from 1994 to 2099 in the calendar.
- The day of the week will be set automatically by adjusting the Year, Month, Date.
- When setting a date that doesn't exist (e.g. 30 Feb.), upon returning to the normal display, the first day of the next month will be displayed automatically.
- Due to the autocalendar, no adjustment at the end of the month is required.

ManualsLib.com

### Adjusting the Calendar CAL. C410

#### <Normal Calendar Display>

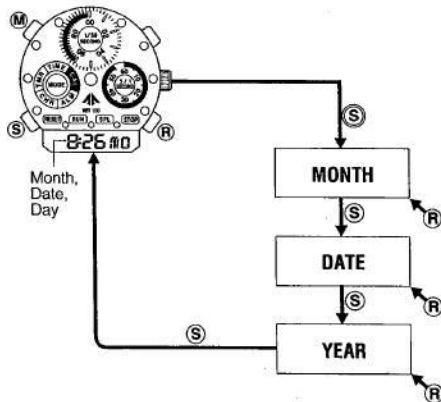

#### <Setting the Calendar>

- (1) Press the **(S)** button in the calendar mode for more than 2 seconds to enter the month adjustment mode.
- (2) Press the **(R)** button to adjust the month digits.
- (3) Press the **(S)** button in the month adjust mode to move to the next adjustment mode.
- (4) Press the **(R)** button to make adjustment. (Press the **(R)** button when setting the calendar to use the quick-advance feature.)

#### • Manual return

- Press the **(M)** button any time during the setting operation to return manually to the normal calendar display.
- When a nonexistent date is set, the first day of the following month will be shown automatically after returning to the normal calendar display.

**(Example)** Feb. 31 → March 1

- The year can be set from 1995 to 2080 and is represented by the last 2 digits of the year.
- The day of the week is automatically set when the year, month and date are adjusted.
- The calendar needs no adjustment at the end of the month.

### Adjusting the Calendar CAL. C420

When the local calendar adjustment for a city is completed, the calendar of other 31 cities will be adjusted automatically calculating time differences.

#### <Normal Calendar Display>

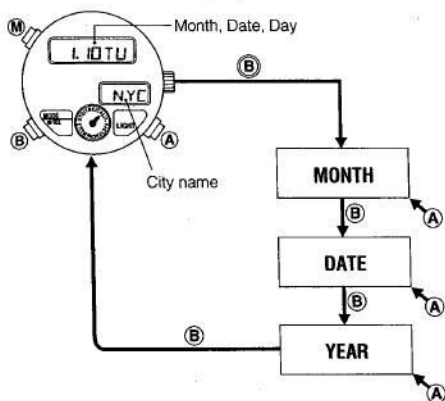

#### <Setting the Calendar>

- 1) Set to the calendar mode by pressing the **(M)** button.
- 2) Press the **(B)** button to select the desired city for adjustment.
- 3) Press and hold the **(B)** button for about 2 seconds until the Month digits start flashing for adjustment. Month can be adjusted by pressing the **(A)** button.
- 4) To adjust other digits, press the **(B)** button. The digits will change as shown in the diagram.
- 5) Adjust the flashing digits by pressing the **(A)** button. Press and hold the **(A)** button for rapid adjustment.

- Auto-return to the normal display will activate when the watch is left in the adjustment mode for more than 2 minutes.
- When the calendar is set to a non-existent date (e.g., February, 30), the display will show automatically the first day of the next month when the display is returned to the normal display.
- Year setting is pre-programmed from 1955 to 2099.
- Month end adjustment is programmed to be set automatically.
- Day of the week is automatically adjusted synchronizing to month, day and year settings.

### Adjusting the Calendar CAL. C430

Refer to "Adjusting the Time and Calendar CAL. C430" or page 10.

## 5-4. Using the Alarm

### Using the Alarm CAL. C400, C401

#### <Alarm Mode>

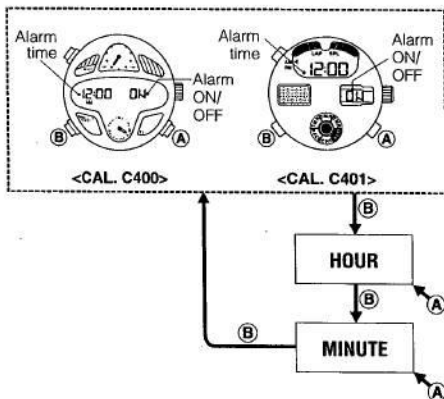

#### <How to Set the Alarm>

- Setting the alarm time uses the same procedure as setting the time and calendar.
- In the alarm mode <ALM> press the (B) button to select the digit to adjust (flashing), then set the time you wish the alarm to sound, with the (A) button.
- When the time mode is in the 12 hour display, the alarm time is also in the 12 hour display, so check the AM/PM.

#### <Setting the Alarm ON/OFF>

- Switch the alarm ON/OFF by pressing the (A) button.

#### <Stopping the Alarm Sound>

- The alarm sound can be stopped by pressing any button.

#### <Sounding Length>

- The alarm will sound for about 20 second.

#### <Alarm Monitor>

- In the alarm mode, the (A) button, while pressing the alarm monitor will sound.

### Using the Alarm CAL. C110

#### <Alarm Mode>

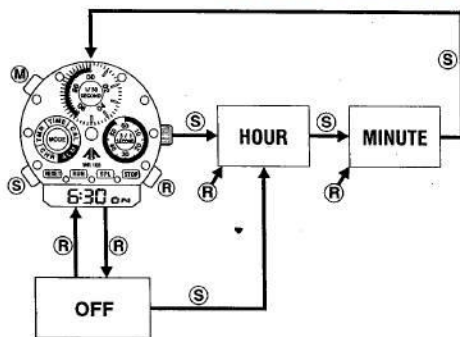

#### <How to Set the Alarm>

- Press the (S) button in the alarm mode for more than 2 seconds to enter the hour adjustment mode. Press the (R) button to adjust the hour digits. Press the (S) button to move to the minute adjustment mode. Press the (R) button to advance the minutes. Press the (S) button to finalize the setting.
- Press the (R) button when setting the alarm time to use the quick-advance feature.
- If the time mode employs the 12-hour systems for the hour display, the alarm set time is also shown by the 12-hour system. AM/PM should be noted.

#### <Setting the Alarm ON/OFF>

- Press the (R) button in the alarm mode to switch the alarm ON/OFF.

#### <Stopping the Alarm Sound>

- The alarm sound can be stopped by pressing any button.

#### <Sound Time Length>

- The alarm will sound for about 20 second.

#### <Alarm Monitor>

- (1) Press the (M) button to access alarm mode (ALM).
  - (2) Press the (R) button for 2 seconds or more and the alarm will sound. Release (R) button and the alarm will stop sounding.
- **Auto return**  
When in the alarm mode display, the watch will automatically return to time mode after about 2 minutes if there is no input.
  - **Manual return**  
Press the (M) button at any time during the setting oper-

## Using the Alarm CAL. C420

The operation of the Alarm-1 and Alarm-2 are the same except the alarm sound.

### <Alarm Mode>

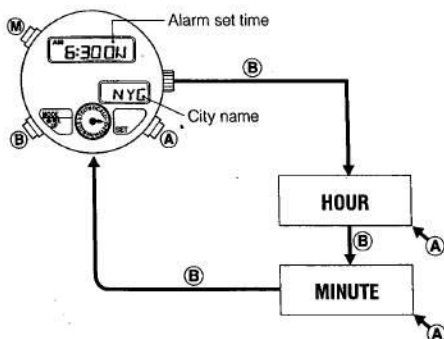

### <How to Set the Alarm>

- 1) Set to the ALM-1 or ALM-2 mode by pressing the **(M)** button.
- 2) Select a city name to set the alarm to the local time.
- 3) Press and hold the **(B)** button for about 2 seconds until the hour digits start flashing to set for adjustment. Adjust the hours by pressing the **(A)** button. Press and hold the **(A)** button for quick adjustment.
- 4) To adjust the minutes digits, press the **(B)** button to change the flashing digits. Adjust the minutes by the **(A)** button.
- 5) Finally press the **(B)** button to complete setting, the display will return to the normal display.

### <Setting the Alarm ON/OFF>

- Press the **(A)** button to set the alarm ON/OFF in the alarm mode.

### <Stopping the Alarm Sound>

- The alarm sound can be stopped by pressing any button.

### <Sounding Length>

- The alarm will sound for about 20 seconds.

### <Alarm Monitor>

- In the alarm mode, while pressing the **(A)** button, the alarm monitor will sound.
- The alarm time setting will be synchronized to the selection of 12-hour/24-hour system in the time mode. Make sure that the AM/PM is set correctly when the 12-hour system is selected.

## Using the Alarm CAL. C430

### <Alarm Mode>

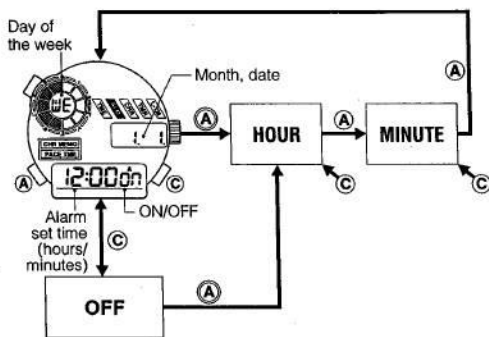

- \* Even if the normal alarm indication is ALARM OFF, if the **(A)** button is pushed and held for about 2 seconds, the indication will change to ALARM ON automatically, then the watch is set in the time setting state.

### <How to Set the Alarm>

- The alarm can be set by following the same procedure as that for the time/calendar adjustment. Select the (flashing) display to be adjusted by pressing the **(A)** button in the alarm mode, and set the time when the alarm sounds by using the **(C)** button.
  - \* If the time/calendar mode employs the 12-hour system for the hours display, the alarm set time is also shown by the 12-hour system, so AM/PM should be noted.

### <Setting the Alarm ON/OFF>

- The alarm can be switched ON/OFF by pressing the **(C)** button in the alarm mode.

### <Stopping the Alarm Sound>

- Press any button to stop the alarm sound.

### <Sound Length>

- The alarm will sound for 20 seconds.

### <Alarm Monitor>

- While the **(C)** button is depressed, the monitoring alarm sounds.

## 5-5. Using the Chronograph

### Using the Chronograph CAL. C400, C401

#### A. Chronograph Mode and Race Chronograph Mode

##### <The Differences in Usages>

Chronograph mode is convenient when measuring normal production rates and split time measurements. Race chronograph mode is convenient when measuring each lap as in a circuit race. Two kinds of data, the best lap time and goal time, can be called up. For detail usage, see explanation in each mode.

##### <Note>

Because chronograph mode and race chronograph mode cannot be used at the same time, select one before using.

If one of the chronograph modes is in the measuring state or stop state (except "00 hours 00 minutes 00.000 seconds display), when changing the modes, you cannot switch to the other chronograph mode.

#### B. Chronograph Mode

- While using race chronograph, this mode cannot be used.

This chronograph can measure and display a maximum of "23 hours 59 minutes 59.999 seconds" in increments of 1/1000 second. After completing 24 hours of measuring it will return to "00 hours 00 minutes 00.000 seconds" and stop.

Also split time (elapsed) measuring is possible.

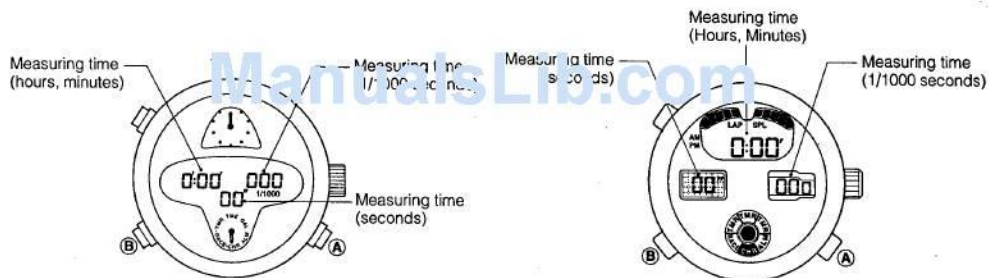

##### <Accumulated Elapsed Time Measurement>

- (1) Start/Stop of chronograph is performed with the **(A)** button. (While measuring, by pressing the **(A)** button, you can repeat start/stop as many times as you like).
- (2) When stopped, press the **(B)** button to reset.

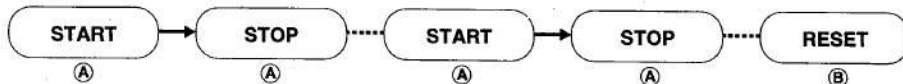

##### <Split Time Measurement>

- (1) Start and stop the chronograph with the **(A)** button.
- (2) While measuring, press the **(B)** button to display the split time for 10 seconds. (While displaying split time, "SPLIT" will flash)
- (3) When stopped, press the **(B)** button to reset.

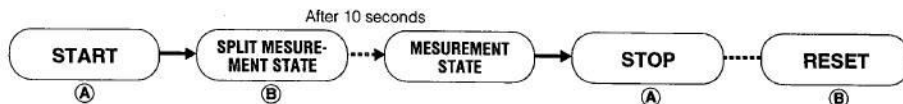

## C. Race Chronograph Mode

- While using chronograph, this mode cannot be used.

This race chronograph can measure maximum 23 hours 59 minutes 59.999 seconds in 1/1000 second increments. After measuring 24 hours, it will return to "00 hour 00 minutes 00.000 seconds" then stop. After measuring the best lap time and goal time (total lap time), each can be retrieved as memo.

### <Accumulated Elapsed Time Measurement>

- Start and stop with the (A) button.

Each time it starts, the lap number gains one, and will display a maximum of "99". After that it will repeat from "00".

\* If the time when it is stopped is shorter than previous times, "BEST" will be displayed under the 1/1000 second display.

- When stopped, press the (B) button to reset.

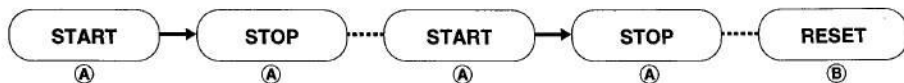

### Note:

Race chronograph starts from 00 hours 00 minutes 00.000 seconds at every starting point.

### <Display on Watch While Timing>

"Minutes, Seconds, 1/1000 second" will display till 60 minutes. After that it changes to "Hours, Minutes, Seconds" display.

#### (CAL. C400)

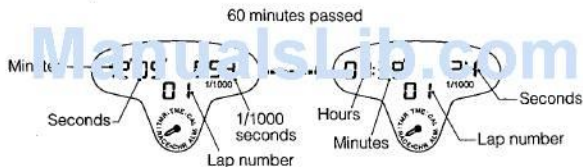

#### (CAL. C401)

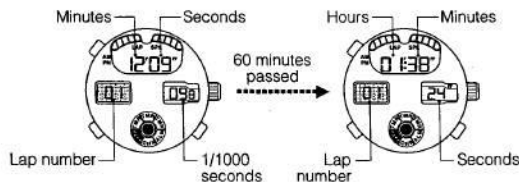

### <Measuring a Series of Laps>

- Start with the (A) button.

- While measuring, press the (B) button to display lap time for 10 seconds. (while displaying lap time, "LAP" will flash)

After displaying lap time for about 10 seconds, it will return to measuring of the next lap automatically. (At that time, the lap number will gain one.)

- By repeatedly pressing the (B) button, you can measure the lap time as many times as you like.

Each time you press the (B) button, the lap number will gain one, and display up to a maximum of "99". After that, it will repeat displaying from "00".

\* In case the time, when it is stopped, is shorter than previous times, "BEST" will be displayed in the digital display.

- When the last lap is measured, press the (A) button to stop. Press the (B) button to reset.

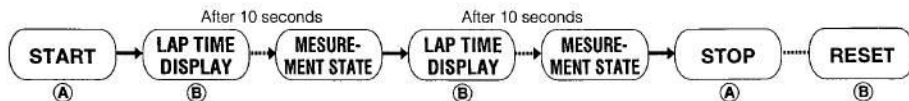

### <Retrieving Memo>

When measuring in race chronograph mode:

The following two types of data will be memorized as memo. You can retrieve them after measurement is completed.

(1) Best lap data: Best lap time and the lap number are displayed at recall.

(2) Goal time data: The time between start and finish, and the lap number are displayed at final stop (goal).

### ~How to retrieve memo~

(1) If the **(B)** button is pushed in the reset state of the race chronograph, the best lap data is indicated.

(2) If the **(B)** button is pushed again, the total time data is indicated.

(3) If the **(B)** button is pushed once again, the watch is set in the reset state again.

#### (CAL. C400)

Set to race chronograph  
reset state

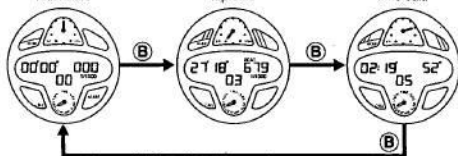

- While displaying memo, it is impossible to start the race chronograph.
- The memo will be deleted with the next start operation after resetting.

#### Note:

Memo will be deleted by the next race chronograph start operation, or the all reset operation, so it would pay to record the necessary data elsewhere.

#### (CAL. C401)

Set to race chronograph  
reset state

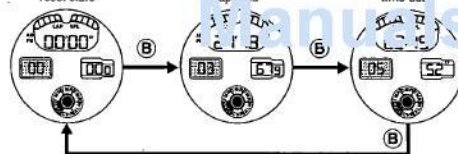

### Using the Chronograph CAL. C410

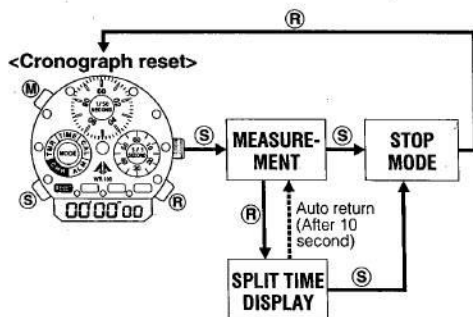

### <Accumulated Elapsed Time Measurement>

- Press the **(S)** button to activate the start/stop switch.
- Press the **(R)** button to take a time reading. A split time will be displayed for about 10 seconds. Press the **(R)** button again while the split time is displayed to record another split time.
- Press the **(R)** button in the stop mode to reset the chronograph.
- Press the **(M)** button in the chronograph mode or during a timing session to switch to another mode.

### <Measurement Time Range:>

00:00'00" ~ 23:59'59"99

Once 24 hours have passed, the chronograph automatically resets and stops.

## Using the Chronograph CAL. C420

- This chronograph can be measured up to 24 hours in 1/1000 second. The chronograph counter will automatically stop after 24 hours measurement and return to the reset state. This chronograph also has the split time measurement function.

### <Reset Mode of the Chronograph>

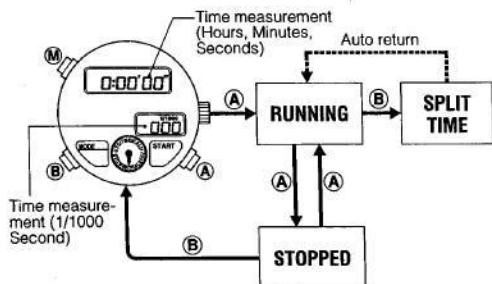

### <Accumulated Elapsed Time Measurement>

- Press the (A) button to start/stop the chronograph. (Time measurement can be repeated to start/stop for any number of times by pressing the (A) button.)
- Press the (B) button to reset the chronograph when the watch is in stop condition.



### <Split Time Measurement>

- Press the (A) button to start/stop the chronograph.
- The split time will be shown with the flashing "SPLIT" mark for 10 seconds by pressing the (B) button while time measurement is continued. The split time will be shown for any number of times by pressing the (B) button.
- To reset the chronograph, press the (B) button when the chronograph is in the stop state.



## Using the Chronograph CAL. C430

### A. Chronograph Mode

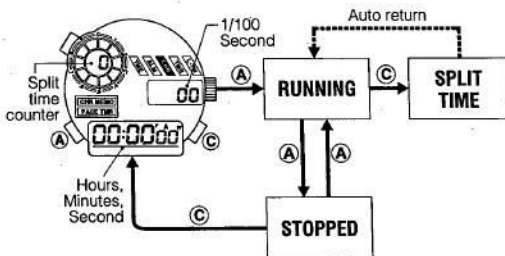

### <Accumulated Elapsed Time Measurement>

- Press the (A) button to start and stop the chronograph. (Stop and start can be repeated any required number of times simply by pressing the (A) button during the chronograph mode.)
- When the (C) button is pressed during the chronograph measurement, the split time is displayed for 10 seconds, after which the running display continues.
- When the (C) button is pressed in the stop state, the chronograph mode is switched to the reset state.

- At 99 hours, 59 minutes, 59 seconds and 99/100 seconds, both chronograph display and split time display revert to zero (reset position).

### <How to Use the Split Counter>

The split counter is used to count the number of starting operations of the chronograph and measurements of split time up to 99.

The split counter counts up by one in the following cases.

- The chronograph is started.
- The split time display (10 sec.) is over.
- The split time measurement is made while a split time is displayed (for 10 sec.)

### <Split Time and Lap Time>

Split time: time elapsed from the starting point to an intermediate point

Lap time: time elapsed in a particular section



### <Chrono-memo function>

Each time a series of start, stop and split time measurements or lap time measurements is performed in the chronograph mode, the memo number is increased by one.

The time measurement and the time when the measurement was finished are recorded as a chrono-memo. This memo can be recalled after the final measurement.

**Note:** Memo numbers 00 to 99 are available, a maximum of 11 memos can be recalled after the measurements.

### <How to Call the Memo>

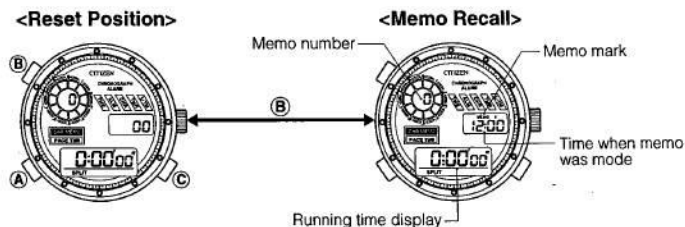

- To call the memo after the measurement is finished, press the **(B)** button while the watch is reset. At this time, the MEMO mark appears.  
Then, if the **(A)** or **(C)** button is pressed, the memo No., time when memo was made, and measured time are indicated in order.  
If the **(A)** button is pressed, the memos from memo No. 0 (time when the measurement started) to memo No. 10 are indicated in order. If the **(C)** button is pressed, those memos are indicated in the reverse order.
- The stored memos can be indicated even while the watch is measuring. Call them through the same procedure as calling after the measurement is finished. Press the **(B)** button to set the watch in the memo-indicating mode. Then, press the **(A)** or **(C)** button to call the memos. If the **(B)** button is pressed, the watch returns to the measurement mode. If the split or lap measuring operation is performed, the measured split or lap is added to the previous record.
- If the memo No. 0 is called, the time when the measurement was started is indicated. The indication of A and P confirms to the 12-hour/24-hour system of "Time and Calendar Mode."
- When there is nothing stored in a memory number, the display at the left will appear. Only the memo number will appear.

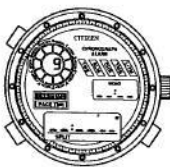

### <Erasing Values Stored in Memory>

- To erase values stored in memory after they have been retrieved, press the **(A)** and **(C)** buttons simultaneously for about 2 seconds.  
There will be a confirmation beep. However, the beginning time (stored in Memory 0) will remain.
- Changing to another mode from Chronograph Memory Mode (by pressing **(B)** button for 2 seconds) will erase all values stored in memory.
- When the chronograph memory is activated after returning to the reset state, anything stored in memory previously will be lost.

In the case of important data, be sure to understand the correct operation of this watch and how to recall the data from memory.  
Make a separate record of the data.

## 5-6. Using the Timer

### Using the Timer CAL. C400, C401

- The timer can be set from 60 minute in one minute decrements. When time is count up, the alarm will sound for about 5 seconds. After that it will return to timer set time.

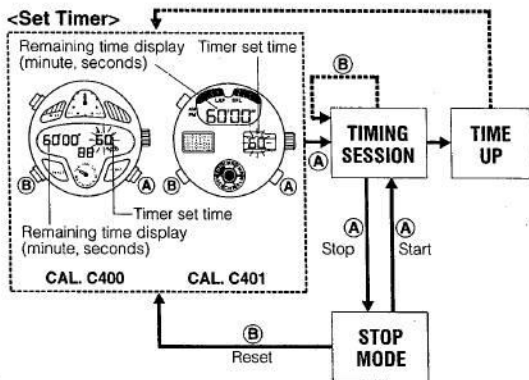

### <Setting the Timer>

In timer mode, while the set time is flashing, each time you press the (B) button, the timer set time will be reduced by one minute.

### <Using the Timer>

- Press the (A) button to start the timer.
- While measuring, press the (A) button to stop the timer. In the stop state, press the (A) button to start again.
- When in stop state, press the (B) button to reset to timer set time.

### <Timer Restart Function (Flyback)>

While using the timer, press the (B) button to return to timer set time manually and restart automatically.

### Using the Timer CAL. C410

- Graphic indication is given in accordance with the time indication.

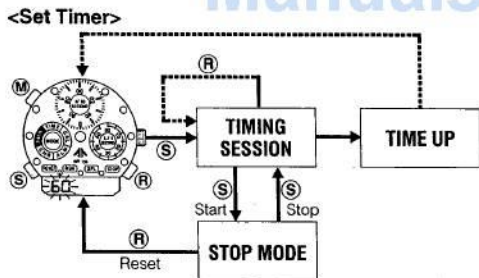

### <Setting the Timer>

The (R) button is used to set the timer. Press and hold down (R) button, quick advance feature.

Timer range: Maximum 60 minutes

### <Using the Timer>

- Use the (S) button to start and stop the timer.
- Press the (R) button in the timer stop mode, to reset the timer set time.
- Press the (R) button while the timer counting down to return the timer set time and restart.
- Then the timer will return to the set time. Press the (M) button in timer mode to switch to time mode. The timing session will continue to run internally although the mode has been switched.

### <Time-up Sound>

When time is count up, the alarm will sound for 5 seconds. Afterward, the timer will be reset to its initial setting.

## Using the Timer CAL. C420

- The timer can be set up to 23 hours 59 minutes in 1 minute. Alarm will sound for 5 seconds when the timer count reaches time-up. Thereafter the display will be reset to the set time.

### <Timer Set Mode>

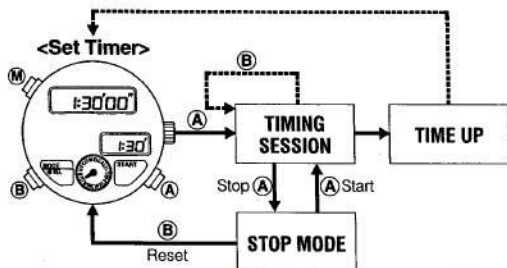
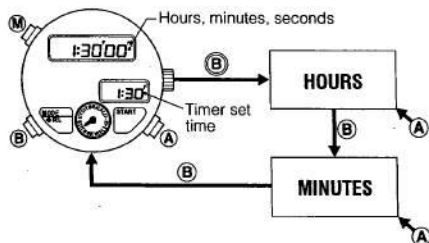

### <Setting the Timer>

- Set to the Timer mode by pressing the **(M)** button.
- Press and hold the **(B)** button for 2 seconds or more. The hours digits will start flashing. Set the hours by pressing the **(A)** button. Press and hold the **(A)** button for rapid advancement.
- Press the **(B)** button to switch for minutes adjustment while the hours digits are flashing. Adjust the Minutes by pressing the **(A)** button.
- Press the **(B)** button again to complete the adjustment. The digit flashing will stop.

### <Using the Timer>

- Press the **(A)** button to start/stop the timer. (The start/stop of the timer countdown can be repeated for any number of times by pressing the **(A)** button.)
- Reset the timer by pressing the **(B)** button while the timer is in stop condition.

### <Fly Back System>

The timer count will be quickly restarted manually from the original setting by pressing the **(B)** button while the timer is timing.

## Using the Timer CAL. C-33

### A. Time Mode

- The timer can be set up to 23 hours 59 minutes 59 seconds in a second.

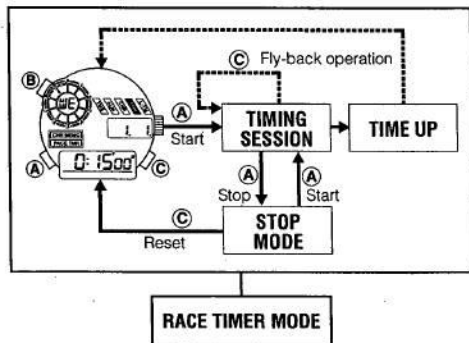
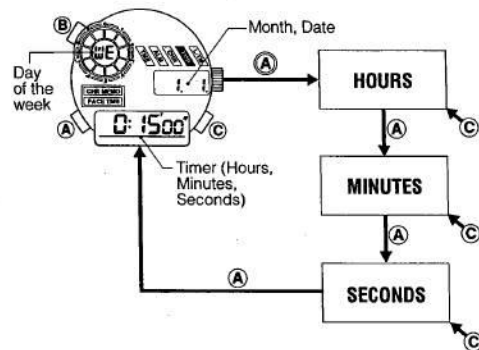

### <Setting the Timer>

- Set to the timer mode by pressing the **(B)** button.
- Press and hold the **(A)** button for 2 seconds or more. The hours digits will start flashing. Set the Hours by pressing the **(C)** button. Press and hold the **(C)** button for rapid advancement.
- To adjust other time displays, select the digits by pressing the **(A)** button. The flashing digits will change in the order as shown in the diagram.
- Adjust the flashing digits by press the **(C)** button.

### <Using the Timer>

When time is count up, the alarm will sound for 5 seconds. Afterward, the timer is reset to its initial setting.

- Use the **(A)** button to start and stop the timer.
- Press the **(C)** button in the timer stop mode, to reset the timer set time.
- Press the **(C)** button while the timer counting down to return the timer set time and restart.

- The timer mode can be changed to another mode while the timer is running.

**Note:** Entering either pace timer mode or chronograph memory mode will cause the timer to stop running and return to its initial setting.

## B. Pace Timer Mode

- The pace timer can be used to set a certain pace for a certain period of time. The pace timer will continue to switch from pace timer 1 to 2 alternately and automatically until stopped.

### <Initial Setting>

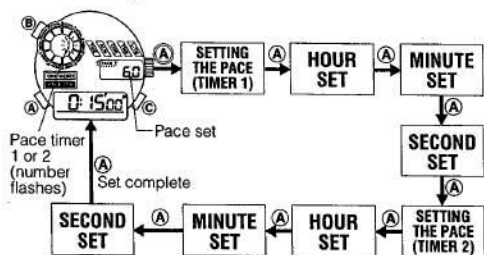

### Common marks for operation

- : Press for 2 seconds or more.
- : Press once.
- ⚡: Flashes

### <How to Set the Pace Timer>

- Switch to pace timer mode (PACE TMR) from timer mode (TMR) by pressing the **B** button for about 2 seconds.
- To set pace timer 1 and 2. Select a segment (hour, minute, second) to be adjusted and set it with the **C** button.

- The pace range for both pace timer 1 and 2 is 60-180 beats per minute.
- The time limit for the pace timer is 23 hours 59 minutes 59 seconds.
- Press the **C** button to switch from pace timer 1 to 2 and back, when at the initial setting mode.
- To conserve the battery, the pace timer pulse automatically shuts off after 15 minutes.
  - If the pace timer is set for a period over 15 minutes and the pace timer pulse mark in ON.
  - More than 15 minutes have passed since switching from one pace timer to the other.

### <Pace Timer 1 Set>

### <Pace Timer 2 Set>

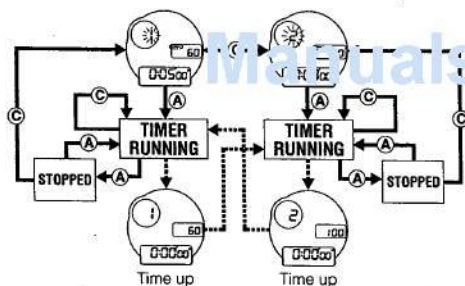

### Common marks for operation

- : Press once.
- ⚡: Flashes

### <Using the Pace Timer>

- Set the two Pace Timers.
- Once the pace timers have been set, it is possible to switch from pace timer 1 to pace timer 2 by pressing the **C** button.
- Press the **B** button to turn on/off the pace timer pulse sound. When the pulse is activated, PACE appears in the pace display area.
- After setting the timers, the pace timer can be started by pressing the **A** button.
- When pace timer 1 reaches zero, as the time up signal is sounding the watch automatically switches to pace timer 2 and begins timing.
- When time is up for pace timer 2, the watch automatically switches back to pace timer 1 and starts timing as the time-up signal is sounding.

### Notes:

- Pulse ON/OFF: When the pace timers have been set, or when they are running, the pulse can be switched on or off by pressing **B** button.
- To return to pace timer initial setting position, press the **A** button to stop the pace timer, then press the **C** button.
- If one of the pace timers has not been set (i.e., it reads "0") then instead of switching to it, the watch will reset the timer that has run out and restart the countdown.
- Pace timer 2 reads "0", so the pace timer cannot switch from 1 to 2. Therefore, it resets pace timer 1 and starts counting down again.
- Since pace timer 2 reads 0:0'00" it is impossible to start the pace timing from pace timer 2.

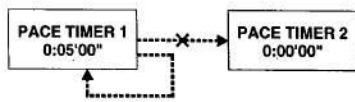

## 5-7. Using the Local Time Mode

### Using the Local Time Mode CAL. C430

- Local time mode displays the local time in another time zone.

#### <Local Time Display>

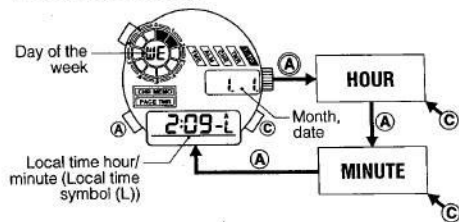

#### Common marks for operation

- : Press for 2 seconds or more.
- : Press once.

#### <How to Set the Local Time>

- Set the local time similarly to the time and calendar. Push the **A** button to make the correction item flash, then correct it with the **C** button.

- Only the local time hour and minute can be set in local time mode. The indicated month, date, and day are those for the time calendar mode (home time).
- The local time minute can be changed by 30 minutes so that the time difference can be adjusted easily.
- If the time and calendar of the time/calendar mode are corrected, the local time hour and minute are automatically corrected at the same time.

## 5-8. Using the Zone Set

### Using the Zone Set CAL. C420

- The zone set is the function to preset the desired cities along the 31 lines of the world for the local time display. This makes easy to monitor the local time of foreign cities.

#### Zone Set Normal Display

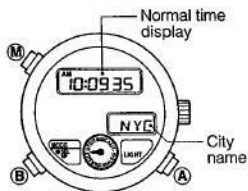

#### Preset Selection Mode

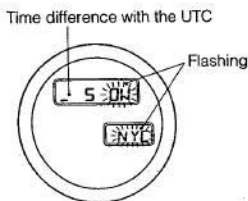

#### <Setting the Time Zone Monitor>

- Set the zone set mode (SET) by pressing the **M** button.
- Select a desired city name for zone setting by pressing the **B** button.
- Press the **B** button again for 2 seconds or more. The "ON" or "OF" mark and city name will start flashing. Switch the zone set on or off by pressing the **A** button while one of these marks is flashing.
- Press the **B** button for summertime setting while the "ON" or "OF" mark and city name are flashing. Set the summertime by pressing the **A** button.
- The zone set display will advance to the next city by pressing the **B** button again. Repeat the same procedure for a multiple time zone setting.
- Press the **M** button to finalize the zone set. The display will return to the normal display and flashing will stop.

## 5-9. Monitoring the UTC (Greenwich time)

### Monitoring the UTC (Greenwich Time) CAL. C420

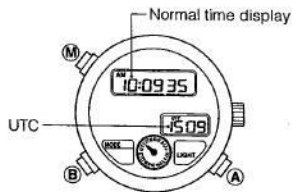

Set to the UTC mode for monitoring the Greenwich mean time by pressing the **M** button. The UTC will always be shown in the 24-hour displaysystem.

## §6. ALL-RESET FUNCTION

Use the All-reset function to reset the watch when the battery has been newly replaced or the watch show irregular operation or display such as continued sounding or no display because of a strong shock.

1. Pull out the crown.
2. Press and hold the **B** buttons simultaneously. All the digital displays will disappear while the buttons are pressed.
3. Release the buttons. All the segment of digital displays will reappear.
4. Push back the crown to hold it for 10 seconds to perform the all-reset. The buzzer will sound in confirmation.
5. The watch will be ready for use after adjusting the displays in each mode.

# §7. DISASSEMBLY AND ASSEMBLY OF MODULE

Disassemble the parts in order of ① → ⑳  
 Assemble the part in order of ⑳ → ①

※ This diagram is common to CAL. C400,  
 C401, C410, C420 and C430.

● Lubrication mark

- ⊖ : A-Lube oil
- ∇ : V-Lube oil
- ⊖ : F-Lube oil
- ∞ : CH-1 oil

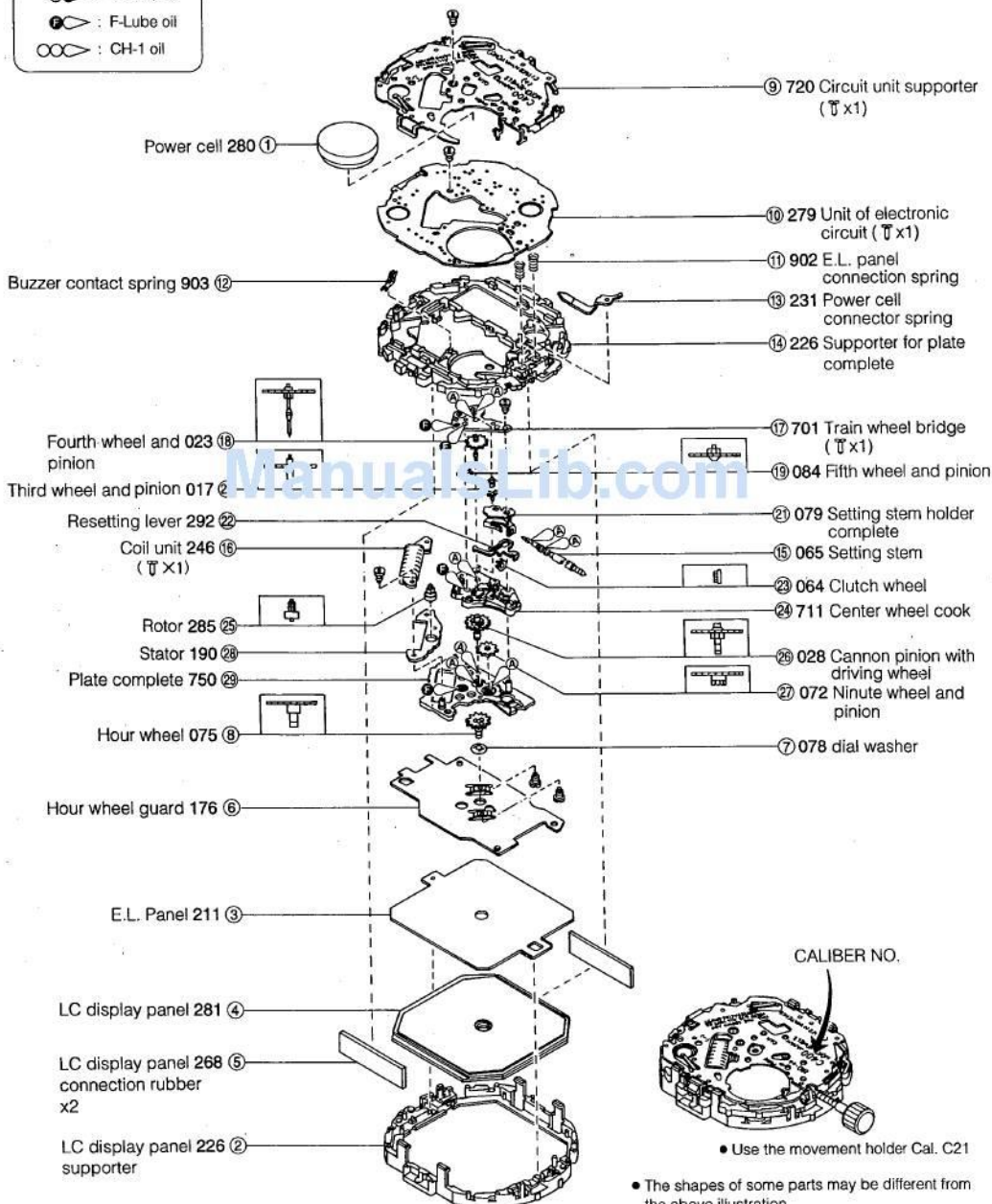

CALIBER NO.

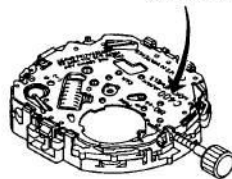

● The shapes of some parts may be different from the above illustration

# §8. TROUBLESHOOTING AND ADJUSTMENT

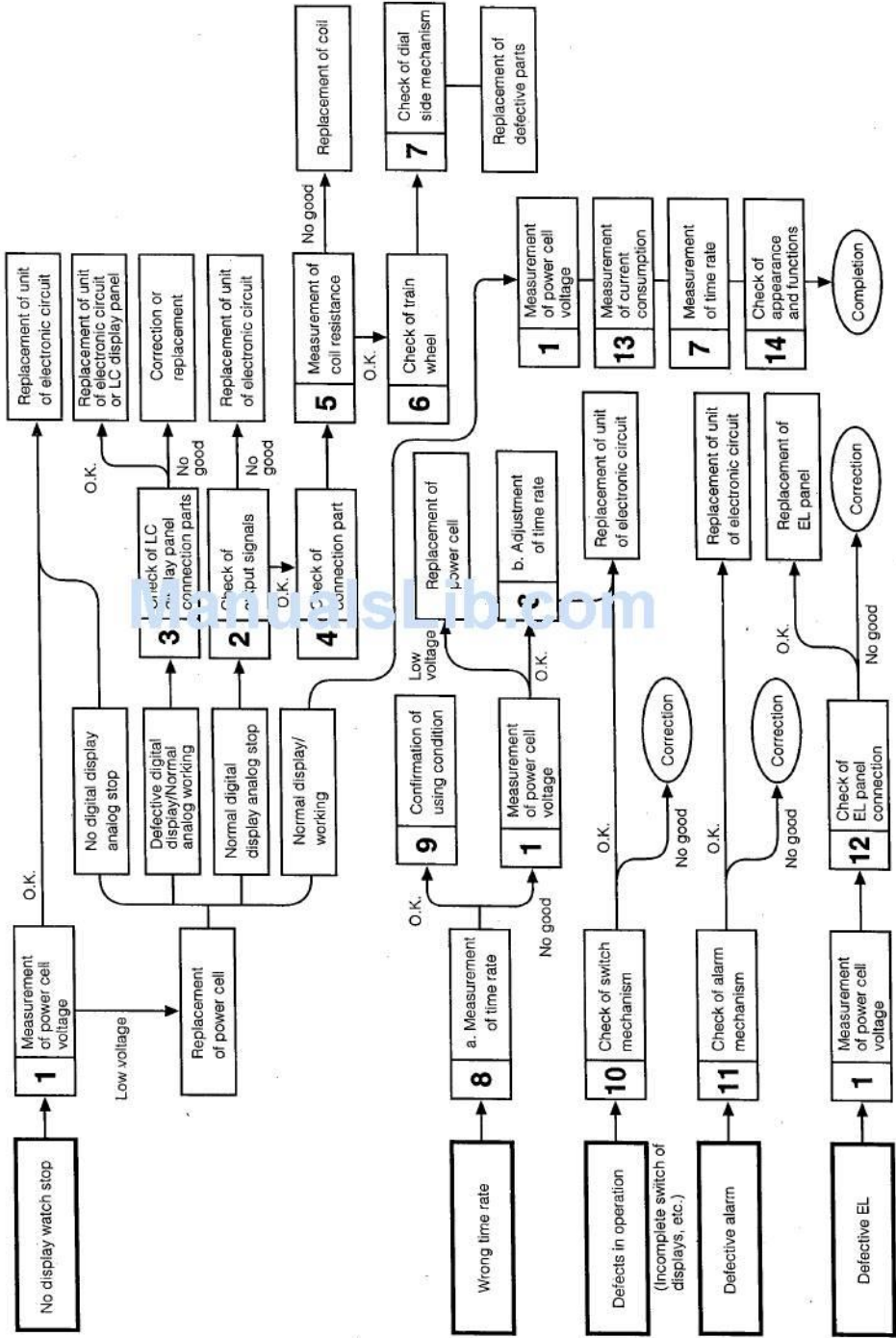

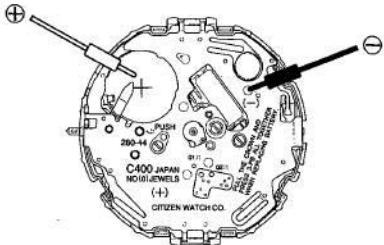
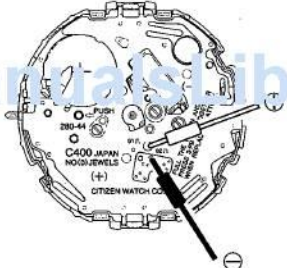
Check Points	How to Check	Results and Treatments
<p>① Measurement of power cell voltage</p>	<p>[Refer to Technical Manual, Basic Course II-1-a]</p> <p>&lt;Tester range: DC 12V&gt;</p> 	<ul style="list-style-type: none"> <li>• <b>Over 1.5 V</b> → Normal</li> <li>• <b>Under 1.5 V</b> → Replace the power cell.</li> </ul>
<p>② Check of output signals</p>	<p>[Refer to Technical Manual, Basic Course II-1-b]</p> <p>&lt;Tester range: DC 0.3V&gt;</p>  <p>(The tester lead pins have no polarity.)</p>	<ul style="list-style-type: none"> <li>• The tester pointer swings every 1 second. → Normal</li> <li>• The tester pointer does not swing. → Check the connections parts.</li> </ul> <p style="text-align: center;">↓</p> <ul style="list-style-type: none"> <li>• The connections are normal. → Replace the unit of electronic circuit.</li> </ul>
<p>③ Check of LC display panel and connection parts</p>	<p>[Refer to the Digital Section of Technical Manual, Basic Course II-2-a]</p> <ul style="list-style-type: none"> <li>• Inspection of all segments Pull out the crown and push the three buttons at the same time to turn on all the segments, and check for defective ones. (Refer to 6 ALL RESET FUNCTION)</li> <li>• Continuity test on LC display panel, cell connection rubber and plate. Check the parts for stain, breakage, etc.</li> </ul>	<ul style="list-style-type: none"> <li>• LC display panel, connection rubber or metal plate is not installed correctly. → Install correctly.</li> <li>• Parts are stained or dirty. → Remove stain and dirt.</li> <li>• Parts are cut broken or scratched. → Replace parts.</li> </ul>
<p>④ Check of connection part</p>	<p>[Refer to Analog Section of Technical Manual, Basic Course II-2-a]</p>	

Check Points	How to Check	Results and Treatments
<p>5 Measurement of coil resistance</p>	<p>[Refer to Technical Manual, Basic Course II-1-c]</p> <ul style="list-style-type: none"> <li>Remove the unit of electronic circuit, then measure the resistance of coil.</li> <li>The tester lead pins have no polarity.</li> </ul> <p style="text-align: right;">&lt;Tester range: R x 10Ω&gt;</p>	<ul style="list-style-type: none"> <li>1.9 kΩ ~ 2.3 kΩ → Normal</li> <li>Outside range of 1.9 kΩ ~ 2.3 kΩ → Replace coil unit.</li> </ul>
<p>6 Check of train wheels</p>	<p>[Refer to Technical Manual, Basic Course II-2-b]</p> <ul style="list-style-type: none"> <li>Check clearance of each wheel. Check rotor for dust and oil.</li> </ul>	
<p>7 Check of dial-side mechanism</p>	<p>[Refer to Technical Manual, Basic Course II-2-c]</p> <ul style="list-style-type: none"> <li>Confirm all parts are not deformed and are lubricated properly.</li> </ul>	
<p>8 Measurement and adjustment of time rate</p>	<p>[Refer to Technical Manual, Basic Course II-2-d]</p> <ul style="list-style-type: none"> <li>Since this watch uses the D.F.C. (digital frequency control) method and has no control terminal, there is no way of adjusting its time rate in the field. (Measurement is made in a 10-second range.)</li> </ul>	<p>The watch loses or gains a substantial amount of time. → Replace the unit of electronic circuit.</p>
<p>9 Confirmation of using condition</p>	<p>[Refer to Technical Manual, Basic Course II-2-e]</p>	
<p>10 Check of switch mechanism</p>	<ol style="list-style-type: none"> <li>Inspection of movement. <ul style="list-style-type: none"> <li>Press the switch spring of circuit unit supporter with tweezers, etc. to contact it to plate complete, and confirm the switching function.</li> <li>Check for removal of pattern of electronic circuit unit, deformation of switch return spring, etc.</li> </ul> </li> <li>Inspection of push button <ul style="list-style-type: none"> <li>Check push button for deformation, stain, etc.</li> </ul> </li> </ol> <div style="border: 1px solid black; padding: 5px; margin-top: 10px;"> <p><b>(Note)</b> Be sure to apply silicone oil to the packing of push button for waterproofness and smooth operation.</p> </div>	<ul style="list-style-type: none"> <li>Switching function is normal. → Inspect push button.</li> <li>Pattern is removed or deformed. → Replace defective parts.</li> <li>Push button is stained or deformed. → Remove stain, or replace push button.</li> </ul>

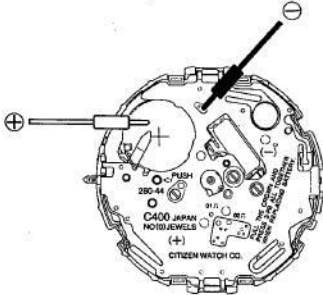
Check Points	How to Check	Results and Treatments
<p>⑪ Check of alarm mechanism</p>	<p>[Refer to Technical Manual, Basic Course II-1-d]</p> <p>*1. Set the module in the case, and check output of alarm signal with the case back removed.</p> <p>(1) Set the watch in alarm mode.</p> <p>(2) Apply ⊕ lead pin to power cell surface and ⊖ lead pin to pattern of buzzer contact spring, then press <b>A</b> CAL, C400, C401, C420, <b>R</b> C410, <b>C</b> C430 button.</p> <p style="text-align: center;">&lt;Tester range: DC 0.3V&gt;</p>  <p>If the output of alarm is normal, perform the following inspection.</p> <ul style="list-style-type: none"> <li>• Check the piezo-electric element of vibrating plate for cracks and breakage.</li> <li>• Check the buzzer contact spring for bend and deformation.</li> <li>• Check the pattern of electronic circuit unit for dust and stain.</li> </ul>	<ul style="list-style-type: none"> <li>• Tester pointer does not swing. → Replace the electronic circuit unit.</li> </ul> <p style="text-align: center;">↓</p> <ul style="list-style-type: none"> <li>• Tester pointer swings. → Normal</li> </ul> <p style="text-align: center;">↓</p> <ul style="list-style-type: none"> <li>• Perform inspection in *2.</li> </ul> <p style="text-align: center;">↓</p> <p>Normal indication. → O.K.</p>
<p>⑫ Check of EL panel connection</p>	<p>1. Confirmation of battery voltage</p> <p>2. Check of EL panel connector.</p> <ul style="list-style-type: none"> <li>• Check the EL panel for breakage. Particularly check the electrode pattern on the back side for stain, breakage, etc. which can lower electrical continuity.</li> <li>• Confirm that the EL connection spring is in contact with the EL panel and electrode pattern normally.</li> </ul> <p>If any cause is not found by inspections 1 and 2, the EL panel must have been deteriorated. Replace the EL panel.</p>	<ul style="list-style-type: none"> <li>• <b>Over 1.5 V</b> → Check EL panel connection.</li> <li>• <b>Under 1.5 V</b> → Replace battery.</li> <li>• <b>Trouble of EL panel</b> → Replace EL panel.</li> <li>• <b>Deformation of EL connection spring</b> → Repair or replace.</li> </ul>

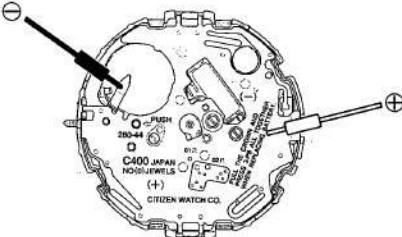
Check Points	How to Check	Results and Treatments
<p>⑬ Measurement of current consumption</p>	<p>[Refer to Technical Manual, Basic Course II-1-f]</p> <p>(1) Set the power cell to tester.</p> <p>(2) Set the lead bars of the tester to the module. Pull the crown and push the three buttons at the same time, then push the crown (The all-reset operation procedure). Then, measure the current consumption.</p> <p style="text-align: center;">&lt;Use the tester range: DC 12<math>\mu</math>A&gt;</p> <div style="text-align: center;">  </div> <p>1. Be sure to measure according to the above procedure. If measurement is not performed according to the above procedure, the watch may indicate and operate abnormally and the current power consumption cannot be measured correctly.</p> <p>2. When the lead bars are applied to the measurement parts, the meter reading may exceeds the maximum value. In this case, wait for about 30 seconds, then measure again.</p> <div style="border: 1px solid black; padding: 5px; margin-top: 10px;"> <p style="text-align: center;"><b>Influence of light</b></p> <p><b>Avoid taking measurements under an incandescent lamp or direct sunshine, because this may cause the current value to increase.</b></p> <p><b>The light of a fluorescent lamp has no influence on current consumption.</b></p> </div>	<p>• Measured value of module complete is <b>under 2.8 <math>\mu</math>A</b>. → Normal</p> <p>• Measured value of module complete is <b>over 2.8 <math>\mu</math>A</b>. → Inspect train wheel and dial side mechanism, and remove dust and stain, and oil.</p> <p>• Pull the crown to measure the power consumption under the reset state.</p> <p style="text-align: center;"><b>Under 2.2 <math>\mu</math>A</b>. → Normal</p> <p style="text-align: center;"><b>Over 2.2 <math>\mu</math>A</b>. → Electronic circuit unit is defective.</p> <p style="text-align: center;">↓</p> <p style="text-align: center;">Replace the electronic circuit unit.</p>
<p>⑭ Check of appearance and functions</p>	<p>[Refer to Technical Manual, Basic Course II-2-f]</p> <ul style="list-style-type: none"> <li>• Check inside of case for dust and stain.</li> <li>• Check operation of setting switches for normality.</li> <li>• Check segment for normality (See 3 Check of LC display panel and connection part.)</li> <li>• Be sure to apply silicone oil to packing of each push button. It is necessary for water resistance and smooth operation.</li> </ul>	