

***TECHNICAL
INFORMATION***

**CITIZEN QUARTZ
Cal. No. 895✕**

 **CITIZEN**

CONTENTS

§1. OUTLINE	P. 1
§2. FEATURES	P. 1
§3. SPECIFICATIONS	P. 2
§4. HANDLING INSTRUCTIONS	P. 3
§5. CIRCUIT DIAGRAM OF MODULE	P. 9
§6. DISASSEMBLY/ASSEMBLY OF MODULE	P. 10
§7. TROUBLE SHOOTING AND ADJUSTMENT	P. 13

§1. OUTLINE



This is a "combination" (Ana-Digi) quartz crystal watch developed for gentlemen with multiple functions coordinated in a thin and small structure. In general a combination watch, featuring a multi-function structure, has disadvantage in the whole thickness of structure since the available space is rather limited for design of a watch. The Citizen technical group, however, has succeeded with the new combination watch to realize a very small thickness of the whole structure — smaller than the Cal. No. 892※※-series watches by 1mm or more with appearance parts. In addition to its multiple functions, some type of this new caliber is available with an alarm function with special water resistance in the appearance structure. Owing to a small and thin structure, the Cal. No. 8950 watch can better fit the user's arm. Thus this new watch will be a new leader among the Citizen's combination watches.

§2. FEATURES

- 1) Combination quartz watch with multiple functions:
In addition to the functions of time, calendar, alarm I, alarm II, chime, stopwatch and timer, the digital section includes such additional functions as an illumination lamp, an alarm monitor and others. On the other hand, the analog section has a center second in addition to the hour and minute hands. And a power cell life indicator tells the user the end of life of the power cell by a different way of second hand's movement from usual way.
- 2) Simple and easy correction of time by crown:
A simple and easy correction is possible for both the digital and analog times.
 - Digital section
The crown is pulled out one step and turned right or left to perform an addition or subtraction of time. (Ineffective with display of calendar).
 - Analog section
The crown is pulled out two steps and turned right or left to perform a correction of time.
- 3) Simplified disassembly and assembly of module:
In comparison with Cal. No. 892※※, the number of component parts is cut by about 25% to simplify the disassembly and assembly of module. The Cal. No. 8950 has many parts that can be used in common to Cal. No. 8930.

§3. SPECIFICATIONS

Caliber No.	8950-02	
Type	Combination quartz crystal watch (with center second)	
Size of module (mm)	28.3 ϕ x 22 x 25 Thickness : 2.38 ^t Thickness at power cell part : 3.1 ^t Thickness at LC display panel part : 3.58 ^t	
Accuracy	± 15 sec./month (at normal temperatures)	
Oscillation	32,768Hz	
Effective temperature range	0°C ~ 55°C (32°F ~ 131°F)	
Method of digital display	FE twist nematic LC (liquid crystal) with 2-split multiplex driving	
Digital functions	Time	Hour, minute, second & A/P
	Calendar	Month, date & day
	Alarm I	Hour, minute & ON/OFF (12-/24-hour display coupling to time display)
	Alarm II	Hour, minute & ON/OFF (12-/24-hour display coupling to time display)
	Chime	Every hour on the hour
	Stopwatch	Minute, second & 1/100 sec. (60 min. count)
	Timer	Minute & second (60 min. count with 1 min. of setting unit)
Analog section	Hour & minute hands plus center second	
Converter	Bipolar step motor (Load compensating circuit)	
Additional functions	<ul style="list-style-type: none"> ●Automatic calendar ●Power cell life indicator ●Illumination lamp ●Alarm monitor ●12-/24-hour switching function 	
Power cell (Silver oxide cell)	Parts No. : 280-44 Code : SR927W (Ag ₂ O/KOH) Nominal voltage : 1.55V Capacity : 55mAH Size : 9.5 ϕ x 2.6mm Lifetime : About 2 years (3 sec. lighting of lamp, 42 sec. ring of alarm plus 24 hourly chimes per day)	

3) Setting of time

① Digital time

The crown is pulled out one step in the time display mode, and thus a flashing is given to indicate a setting state of time.

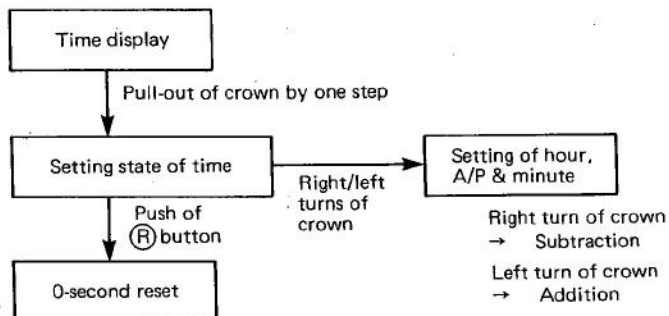
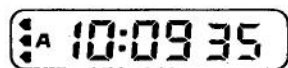

② Analog time

When the crown is pulled out two steps in the time display mode, the movement of second hand stops for setting of an analog time.

In this instant, the time display is given at the digital portion. And this digital time display is not affected by turning of the crown.

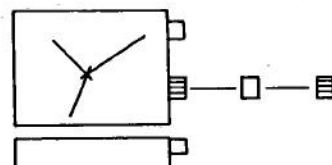

Crown pulled out two steps for setting of analog time

③ Synchronization between digital and analog seconds

Analog time (8:20'45'') to be synchronized with digital time (10:09'30'' AM)

- The crown is pulled two steps to set the analog time to 10:09''. (The second hand stops at 45 sec.)
- The crown is pushed into the normal position after making sure the digital second of 45 sec.

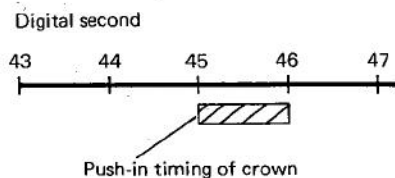

④ Correction of ± 30 sec.

- The crown is pulled one step in the time display mode to secure a setting state of digital time.
- The (R) button is pushed synchronizing with a time signal, and thus the digital second is reset to 0. While the analog second hand is also reset to 0.

Change of analog/digital displays in 0-reset at N seconds.

Before 0-reset	After 0-reset	
	Digital	Analog
$0 \leq N < 30$	00 sec. with no change in minute	Waiting for N-sec. count
$30 \leq N < 60$	00 sec. with carry of one minute	Quick advance (32Hz) of: (60-N) seconds

§4. HANDLING INSTRUCTIONS

1) Functions of push-buttons and crown

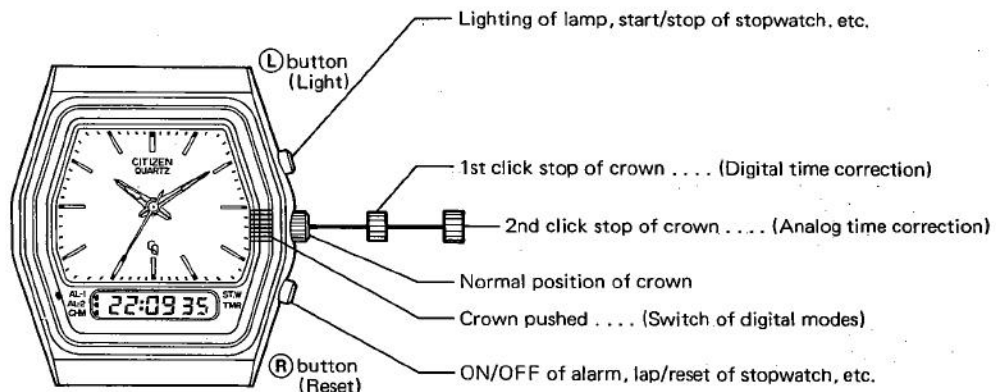

2) Switch of digital modes

A switch is given among the digital modes with every push of the crown. (The flashing is shown by O.)

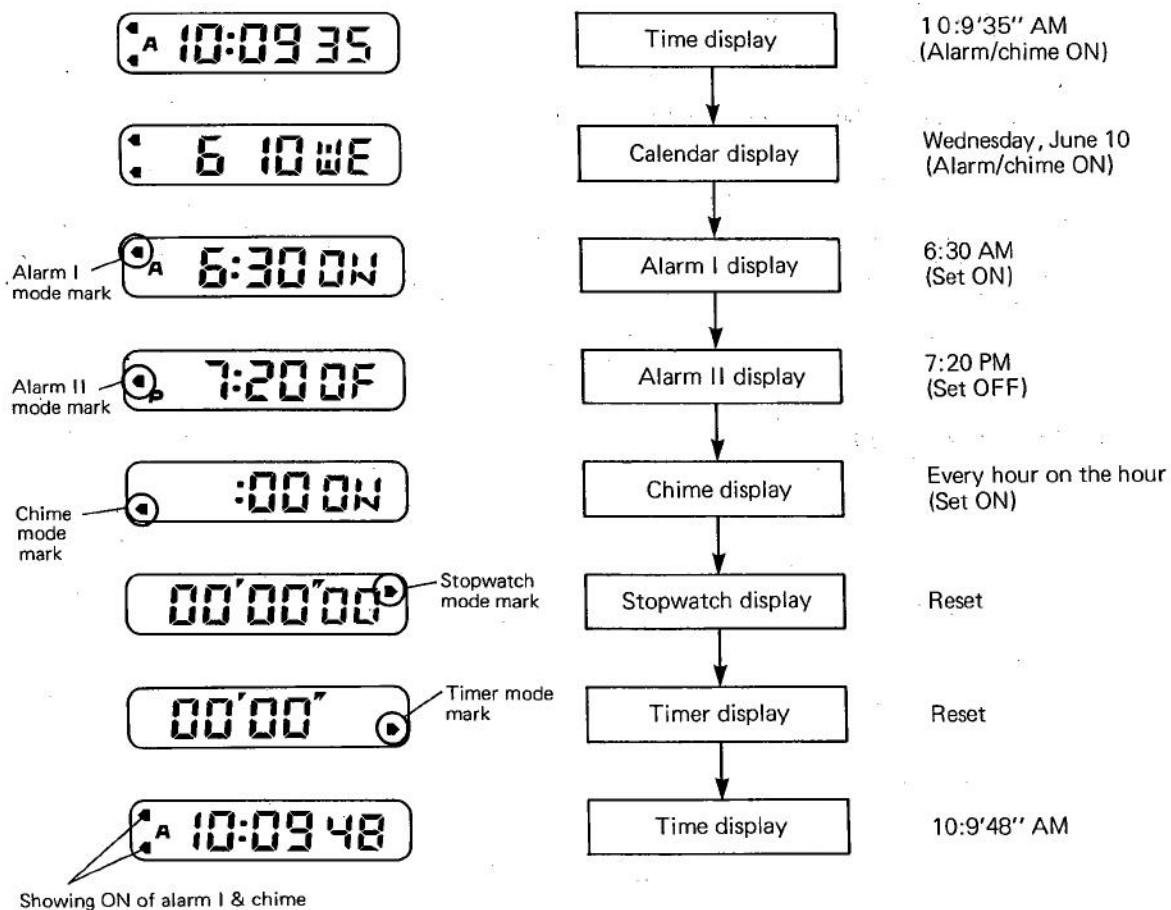

6) **Function of alarm II**

An alarm II display is obtained by pushing once the crown in the mode of alarm I display. Handling of alarm II is identical with alarm I excepting mode marks.

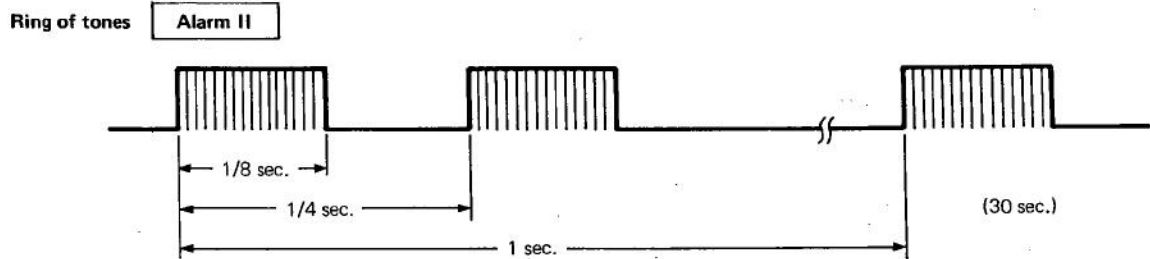

7) **Function of chime**

A chime display is obtained by pushing once the crown in the mode of alarm II display. The ON and OFF are switched alternately with every push of (R) button after pulling out the crown one step.

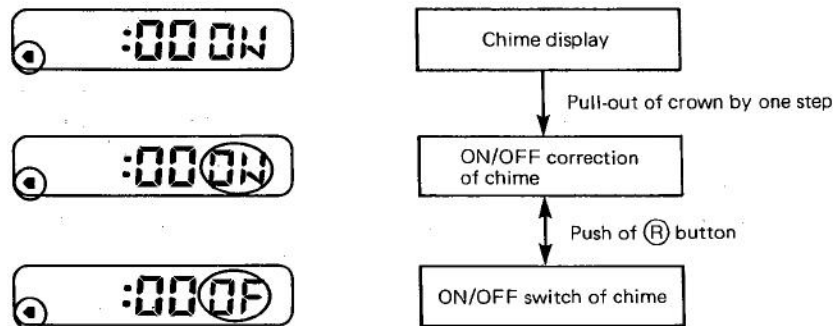

The chime sounds twice (beep, beep) every hour on the hour after setting the chime.

8) **Function of stopwatch**

A stopwatch display is obtained by pushing once the crown in the mode of chime display.

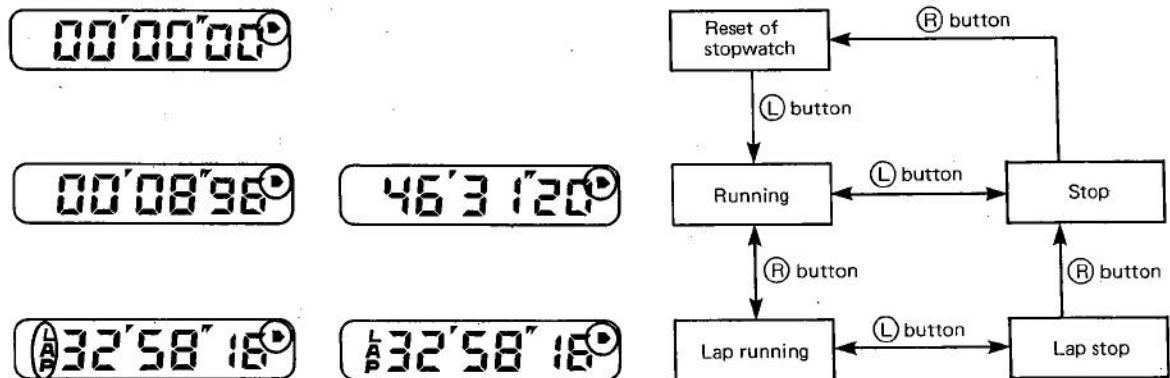

- The stopwatch counts up to one hour, and the counting repeats in a cycle of 59'59'99 → 00'00'00.
- An alarm tone is produced with push of start/stop (L) button.
- The lamp does not go on in the stopwatch mode even with push of (L) button.

Note 1) The digital time must be set prior to the analog time. This is due to the fact that the analog second is regulated by a digital 0-reset. And thus an agreement, if once obtained, is maintained between the digital second and the analog second hand.

Note 2) When a 0-reset is given while the digital second reads 30~59, the minute is carried toward the minute, hour, A/P and then date in that order.

4) Setting of calendar

A calendar display is obtained by giving a push to the crown in the time display mode.

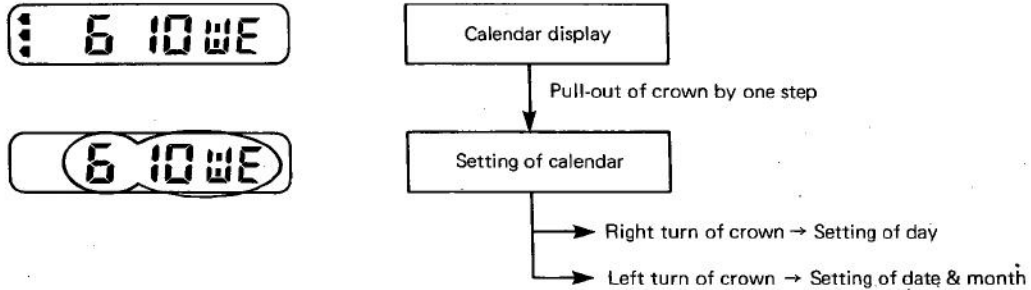

Note 1) In a setting of calendar, the 1st and 2nd signals have no reaction since they function to just catch the rotating direction of crown. The setting action starts with the 3rd signal.

Note 2) An automatic decision is given between the 31-day and 30-day months with no display of a non-existing date.

In a leap year February 29 can be set although a 28-day display is given to the February of ordinary years.

5) Function of alarm I

An alarm I display is obtained by pushing once the crown in the calendar display mode. The alarm time is set by pulling out the crown one step and turning it right or left.

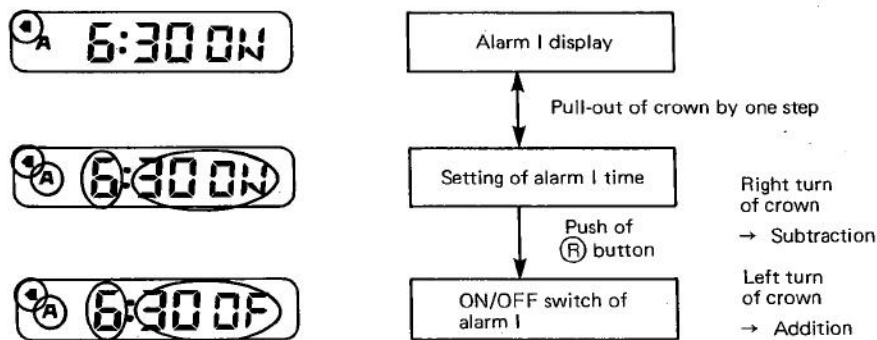

Ring of tones **Alarm I**

The alarm rings 30 seconds and can be stopped any moment with push of either push-button.

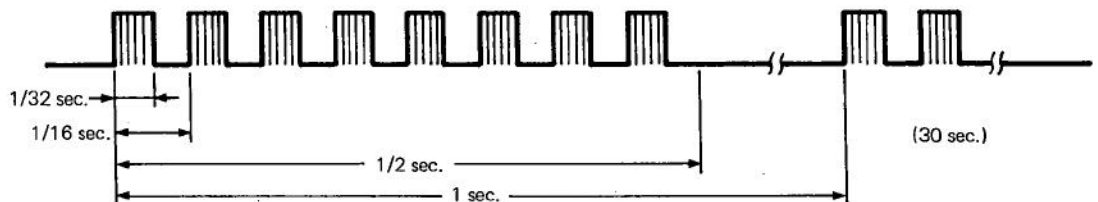

11) All-reset function

The all-reset function works with a simultaneous push of (L) and (R) buttons after pulling out the crown two steps.

	Time display
	Calendar display
	Alarm I display
	Alarm II display
	Chime display
	Stopwatch display
	Timer display

12) Decision of correcting direction

Each digital function is corrected by pulling out the crown one step and then turning it. In this case, the flashing showing an under-correction state ceases with the 1st signal. Then a correction starts with the next signal. The flashing starts again in case the following signal is not given in about 2 seconds after the first ceasing of flashing. Thus the next signal is used for a decision of direction, and a correction starts with the following second signal. A turn of the crown gives 30 signals.

13) Full-segment glow

All display segments glow at a time with a simultaneous push of (L) and (R) button plus the crown each.



This full-segment glow can be used conveniently for a check of the segment break, etc.

In such case, a time display is given regardless of the precedent mode of display. (The 12-/24-hour switching function may sometimes work.)

9) Function of timer

A timer display is obtained by pushing once the crown in the mode of stopwatch display.

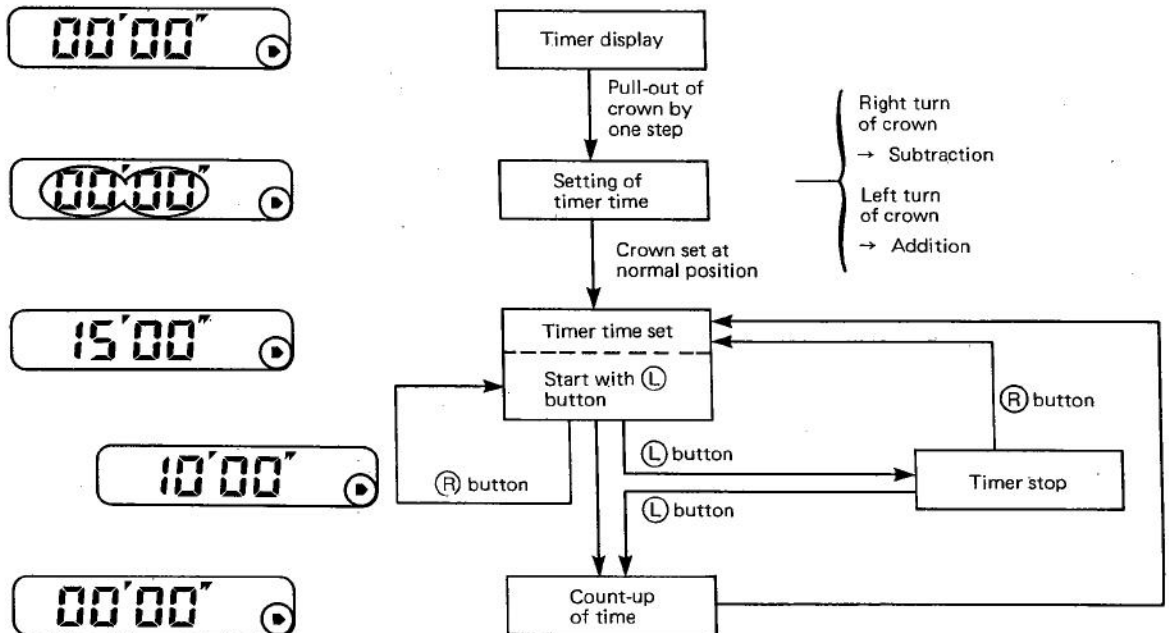

- The timer time from a count-up to an exact second differs by the start timing of the timer.
- The timer counts in a range of 1~59 minutes.
- The lamp does not go on in the timer mode even with push of (L) button.
- An alarm tone is produced for 10~20 seconds when the timer counts up the set time.
- A ring identical with Stopwatch is obtained with push of (L) button in the working mode of timer.

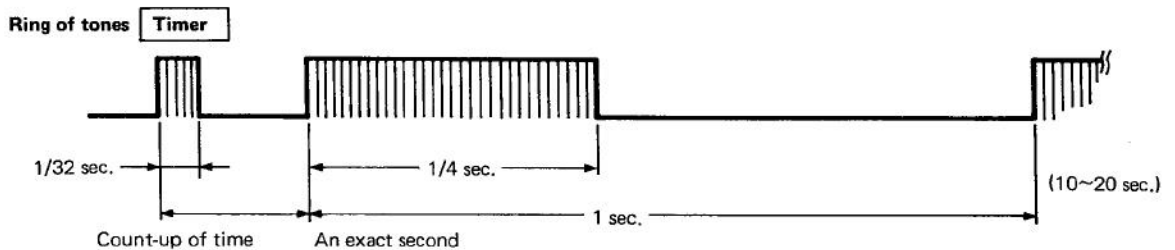

- The ring can be stopped any moment with push of either one of the crown, (L) and (R) buttons for the timer.

10) Alarm monitor and 12-/24-hour switch function

A sound of alarm monitor is produced with a simultaneous push of (L) and (R) buttons in each display mode (excepting the mode of correction).

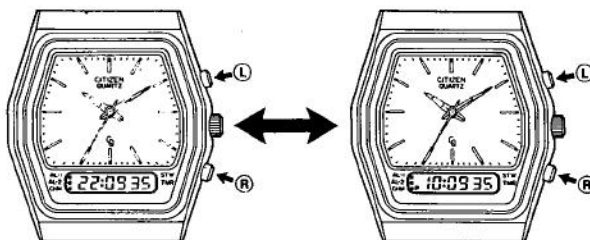

The 12- and 24-hour displays are switched alternately with every actuation of the switching function in the working mode of time display.

- The ring of an alarm monitor is identical with Alarm I.