



LTP1245X-X384-E
LINE THERMAL PRINTER MECHANISM
TECHNICAL REFERENCE

U00085320001

Seiko Instruments Inc.

LTP1245X-X384-E LINE THERMAL PRINTER MECHANISM TECHNICAL REFERENCE

Document Number U00085320001

First Edition December 2003
Second Edition March 2005

Copyright © 2003, 2005 by Seiko Instruments Inc.
All rights reserved.

Seiko Instruments Inc. (SII) has prepared this manual for use by SII personnel, licensees, and customers. The information contained herein is the property of SII and shall not be reproduced in whole or in part without the prior written approval of SII.

SII reserves the right to make changes without notice to the specifications and materials contained herein and shall not be responsible for any damages (including consequential) caused by reliance on the materials presented, including but not limited to typographical, arithmetic, or listing errors.

SII is a trademark of Seiko Instruments Inc.

PREFACE

This reference manual describes the specifications and basic operating procedures for the LTP1245 (for RoHS) Line Thermal Printer Mechanism.

For the LTP1245 (RoHS supporting), four models are available:

- LTP1245R-C384-E
- LTP1245S-C384-E
- LTP1245T-S384-E
- LTP1245U-S384-E

In this reference manual, the information mentioned as LTP1245 is common to all models unless otherwise noted, and if the information is different depending on the model, specific model name is mentioned clearly.

Chapter 1 “Precautions” describes safety, design and operational precautions. Read it thoroughly before designing so that you are able to use the LTP1245 properly.

SII has not investigated the intellectual property rights of the sample circuits included in this manual. Fully investigate the intellectual property rights of these circuits before using.

Also, when designing the circuits based on the sample circuits in this reference manual, use them after thorough verification.

TABLE OF CONTENTS

Section		Page
CHAPTER 1 PRECAUTIONS		
1.1	SAFETY PRECAUTIONS	1-1
1.2	DESIGN AND HANDLING PRECAUTIONS	1-2
1.2.1	Design Precautions	1-2
1.2.2	Handling Precautions	1-3
1.2.3	Precautions on Discarding	1-4
CHAPTER 2 FEATURES		
CHAPTER 3 SPECIFICATIONS		
3.1	GENERAL SPECIFICATIONS	3-1
3.2	HEAT ELEMENT DIMENSIONS	3-3
3.3	PAPER FEED CHARACTERISTICS.....	3-4
3.4	STEP MOTOR CHARACTERISTICS.....	3-5
3.4.1	Motor Drive Circuit.....	3-6
3.4.2	Motor Timing.....	3-8
3.4.3	Precautions for Driving the Motor.....	3-10
3.5	THERMAL HEAD	3-14
3.5.1	Structure of the Thermal Head.....	3-14
3.5.2	Printed Position of the Data.....	3-16
3.5.3	Head Resistance	3-17
3.5.4	Head Voltage.....	3-17
3.5.5	Peak Current	3-17
3.5.6	Thermal Head Electrical Characteristics.....	3-18
3.5.7	Timing Chart.....	3-19
3.6	CONTROLLING THE HEAD ACTIVATION (DST) PULSE WIDTH.....	3-20
3.6.1	Calculation of the Head Activation Pulse Width.....	3-20
3.6.2	Calculation of the Applied Energy	3-20
3.6.3	Adjustment of the Head Activation Voltage.....	3-21
3.6.4	Adjustment of the Head Resistance.....	3-21
3.6.5	Determination of Activation Pause Time and Activation Pulse Period.....	3-22
3.6.6	Head Activation Pulse Term Coefficient.....	3-22
3.6.7	Calculation Sample for the Head Activation Pulse Width	3-23
3.6.8	Thermistor Resistance	3-24
3.6.9	How to Print Using 2-ply Thermal Paper.....	3-25
3.6.10	Detecting Abnormal Temperatures of the Thermal Head.....	3-26
3.7	HEAD-UP/PAPER DETECTOR	3-27
3.7.1	General Specifications	3-27
3.7.2	Sample External Circuit.....	3-28
3.7.3	Automatic Paper Load.....	3-29
3.8	Mode Code Label	3-30

Section		Page
---------	--	------

CHAPTER 4 CONNECTING EXTERNAL CIRCUITS

4.1	THERMAL HEAD CONTROL TERMINALS.....	4-2
4.2	MOTOR AND DETECTOR TERMINALS.....	4-3

CHAPTER 5 DRIVE METHOD

5.1	THERMAL HEAD DRIVE TIMING.....	5-1
5.2	MOTOR DRIVE TIMING	5-2

CHAPTER 6 HOUSING DESIGN GUIDE

6.1	SECURING THE PRINTER	6-1
	6.1.1 Printer Mounting Method.....	6-1
	6.1.2 Precautions for Securing the Printer	6-1
6.2	LAYOUT OF PRINTER AND PAPER	6-2
6.3	WHERE TO MOUNT THE PAPER HOLDER	6-2
6.4	WHERE TO MOUNT THE PAPER CUTTER.....	6-2
6.5	OUTER CASING STRUCTURE.....	6-3

CHAPTER 7 APPEARANCE AND DIMENSIONS

CHAPTER 8 LOADING/UNLOADING PAPER AND HEAD CLEANING

8.1	LOADING/UNLOADING PAPER PRECAUTIONS.....	8-1
8.2	HEAD CLEANING PROCEDURE AND PRECAUTIONS.....	8-3

CHAPTER 9 PERIPHERAL EQUIPMENT

9.1	AUTOCUTTER UNIT	9-1
	9.1.1 Installation.....	9-2
	9.1.2 Opening and Closing the Autocutter Unit.....	9-3
	9.1.3 Inserting Recording Paper	9-4
	9.1.4 Clearing Paper Jams	9-4
	9.1.5 Hints for Use.....	9-5
	9.1.6 External View when the LTP1245 is equipped with the Autocutter.....	9-6
9.2	LTP1245 MOUNT (OP-L1245A-E).....	9-7
	9.2.1 Installation.....	9-7
	9.2.2 OP-L1245A-E External View	9-8

FIGURES

Figure		Page
3-1	Heat Element Dimensions	3-3
3-2	Print Area.....	3-3
3-3	Sample Drive Circuit (Motor)	3-6
3-4	Input Voltage Signals for the Sample Drive Circuit (Motor)	3-7
3-5	Motor Start/Stop Timing (Sample Drive Circuit (Motor))	3-8
3-6	Motor Drive Timing Chart (in use at temperature over -5°C)	3-10
3-7	Motor Drive Timing Chart (in use at temperature below -5°C).....	3-11
3-8	Thermal Head Block Diagram	3-15
3-9	Printed Position of the Data.....	3-16
3-10	Timing Chart.....	3-19
3-11	Thermistor Resistance vs. Temperature	3-24
3-12	How to Drive 2-ply Thermal Paper	3-25
3-13	Sample External Circuit of the Head-Up/Paper Detector.....	3-28
3-14	Flowchart for Automatic Paper Load.....	3-29
3-15	Model Code Label	3-30
4-1	Thermal Head Control Terminals (FFC).....	4-2
4-2	Motor and Detector Terminals (FPC)	4-3
5-1	Example of Timing Chart of the Thermal Head Driving	5-1
5-2	Example of Motor Drive Timing Chart	5-4
6-1	Paper Layout	6-2
6-2	Sample Outer Casing Structure	6-3
7-1	LTP1245R-C384-E Appearance and Dimensions	7-2
7-2	LTP1245S-C384-E Appearance and Dimensions	7-3
7-3	LTP1245T-C384-E Appearance and Dimensions.....	7-4
7-4	LTP1245U-C384-E Appearance and Dimensions	7-5
8-1	Head Cleaning Procedure	8-3
9-1	Installation	9-2
9-2	Designing a Mount	9-3
9-3	Opening and Closing of Autocutter Unit.....	9-3
9-4	Head-up Lever Position.....	9-3
9-5	Best Cutting Position for Efficient Paper Use	9-5
9-6	External View when the LTP1245 is equipped with the Autocutter	9-6
9-7	LTP1245 Mount Installation.....	9-7
9-8	LTP1245 Mount External View (OP-L1245A-E).....	9-8

TABLES

Table		Page
3-1	General Specifications	3-1
3-2	Sample Motor Drive Frequency	3-4
3-3	General Motor Specifications	3-5
3-4	Excitation Sequence.....	3-7
3-5	Acceleration Steps	3-13
3-6	Blocks and Activated Heat Elements	3-16
3-7	Head Voltage.....	3-17
3-8	Thermal Head Electrical Characteristics.....	3-18
3-9	Activation Pulse Width.....	3-23
3-10	Temperature and Corresponding Thermistor Resistance.....	3-25
3-11	Detector's Status and Output Signals	3-27
3-12	Absolute Maximum Ratings of Detectors.....	3-27
3-13	Detectors Input / Output Conditions	3-28
4-1	Recommended Connectors	4-1
4-2	Thermal Head Control Terminal Assignments	4-2
4-3	Motor and Detector Terminals Assignments.....	4-3

CHAPTER 1

PRECAUTIONS

Read through this manual to use the printer properly.

Also, design the product taking the detailed precautions that are noted in each section into consideration.

- This reference manual subjects to change without notice.
Ask the latest information of the printer to our service.
- Damage due to improper handling of the printer without following the instruction described in this reference manual will not be responsible for SII.
- To use the printer safely, design the product taking the precautions described below into consideration.
Also, attach the safety precautions to all of user's manuals to further inform the users concerning usage safety.

1.1 SAFETY PRECAUTIONS

To use the printer safely, design the product taking the precautions described below into consideration.

Also, attach the safety precautions to all of user's manuals, as well as place warning labels on the products to further inform the users concerning usage safety.

- **Precautions to prevent the thermal head from overheating**
If the thermal head heat element, which always has electricity supplied by the CPU, malfunctions, the thermal head may overheat, causing smoke and fire.
To prevent personal injury, the printer should be controlled so that the detection of abnormal temperatures of the thermal head is performed as described in **Section 3.6.9**.
Turn printer off immediately if abnormal conditions occur.
- **Precautions on temperature of the thermal head when handling**
Design the outer case to prevent the user from being burnt by touching the thermal head and its periphery directly due to the fact that the thermal head and its periphery are hot when printing and remains so immediately after printing. Regarding paper insertion and head cleaning, prepare caution descriptions in the manual stating to perform these operations after the head temperature drops. To allow cooling, insert clearance between the head and the outer case in designing the outer case.
- **Precautions regarding raising the temperatures of the motor**
Give warning to prevent the user from being burnt by touching the thermal head directly due to the fact that the motor is hot when operated and remains so immediately after operating. To allow cooling, insert clearance between the head and the outer case in designing the outer case.
- **Precautions regarding sharp edges of the printer body**
The printer body and/or some parts may have some sharp edges. Design the outer case to prevent the user from being injured by touching said sharp edges and provide warnings concerning this.

1.2 DESIGN AND HANDLING PRECAUTIONS

To maintain the initial level of performance of the LTP1245 and to prevent future problems from occurring, observe the following precautions.

1.2.1 Design Precautions

- If too much energy is applied to the thermal head, it may overheat and become damaged. Always use the printer with the specified amount of energy. Do not input a pulse over than 2V and 20 nsec to each signal terminal of the thermal head.
- Use C-MOS IC chips (74HC240 or equivalent) for CLK, LATCH, DAT and DST signals of the thermal head.
- When turning the power on or off, always DISABLE (put in “Low” state) the DST terminals.
- To prevent the thermal head from being damaged by static electricity:
 - Fix the printer to the Frame Ground (FG) by the FG connection parts as shown in **Figure 7-1**.
 - Connect the GND terminal (SG) to FG through an approximate 1 MΩ resistor.
- Keep the Vp power off when not printing in order to prevent the thermal head from becoming electrically corroded. In addition, design the printer so that the signal GND of the thermal head and the frame GND of the printer mechanism become the same electric potential.
- Make the wire resistance between the power supply and the Vp as well as GND terminals on the thermal head controller as small as possible (below 50 mΩ). Maintain a considerable distance from signal lines to reduce electrical interference.
- Surge voltage between Vp and GND should not exceed 10 V.
- As a noise countermeasure, connect the capacitor noted below between Vdd and GND pins near the thermal head control connector.

Vp ↔ GND: approximately 10 μF
Vdd ↔ GND: approximately 1 μF

- Turn on power in the following manner:

At power ON:	1) Vdd (5 V)	→	2) Vp
At shut down:	1) Vp	→	2) Vdd (5 V)
- Always detect the outputs of the head up detectors and paper detectors. Incorrect activation of the thermal head may reduce its longevity and the platen, and damage the thermal head and the platen.
- To prevent malfunction of the detector, design the printer so that the infrared ray is not input around the head up detector.

- Design the outer case so that the thermal head control terminals can move after fixing to the connector because they move 2 to 3 mm due to the up/down action of the thermal head.
- Design the outer case so that it prevents the paper feed out from being caught in the platen.
- If the thermal head remains in contact directly with the platen, they may stick tight each other. When the printer is not in use, put the paper between the thermal head and platen or place the thermal head in an upward position. If the thermal head and the platen stick tight, it is only necessary to release the thermal head so that the problem can be avoid.
- Design software that will deactivate the heat elements if the thermal head thermistor (TH) detects a temperature higher than 80 °C (thermistor resistance $R_{TH} \leq 2.48 \text{ k}\Omega$), and reactivate the heat elements when a temperature lower than 60 °C ($R_{TH} \geq 4.46 \text{ k}\Omega$) is detected. If the thermal head continues to be activated at a temperature higher than 80 °C, the life of the thermal head may be shortened significantly.
- The cutting surface of the motor flange may generate discoloration and rust according to operating condition.
This is no problem for functions, however, take it into external view consideration.

1.2.2 Handling Precautions

Incorrect handling may reduce the efficiency of the printer and cause damage. Handle the printer with the following precautions.

Also, get an operator's attention.

- To prevent the heat elements, ICs, etc. from being damaged due to static electricity, take measures against electrification for both machine and human before handling the printer. Care should be taken in particular regarding the thermal head control terminals when handling.
- Do not apply stress to the thermal head control terminals; otherwise connectors, FPC (Flexible Printed Cable) and FFC (Flexible Flat Cable) for the thermal head may be damaged.
- If any paper other than that specified is used, a high print quality and longevity of the thermal head cannot be guaranteed.
Possible problems that may occur are:
 - Poor printing quality due to low-sensitive paper
 - Abrasion of the thermal head due to a paper surface which is too rough
 - Sticking between the thermal layer of the paper and the thermal head resulting in excessive noise when printing
 - Print fading due to low print preservation
 - Corroded thermal head due to poor thermal layer of the paper.
- Do not activate without paper; otherwise, the platen or thermal head may become damaged.
- Do not hit or scratch the surface of the thermal head with sharp or hard objects. It may become a source of damage to the heat element.
- The thermal head is pressurized at the time of delivery from the factory. Place the thermal head in an upward position before use. The head down, neutral and head up positions can be set with the head up/down lever.

- Connect or remove the connectors after powering off the printer.
- When printing at a high print rate (black or zigzag pattern) in a low temperature or high humidity environment, the vapor from the paper during printing may cause condensation to form on the printer or may soil the paper itself.
Keep the thermal head away from water drops.
It may become the source of a corroded thermal head.
If condensed, power off the Vp until dried.
- The LTP1245 is not a water-proof printer. Prevent contact with water and do not perform operations with wet hands. They may become sources of damages to short circuits, overheating and fire.
- The LTP1245 is not a dust-proof printer. Use in a dusty place may cause damage to the thermal head and cause paper feed problems.

1.2.3 Precautions on Discarding

When discarding used printers, discard them according to disposal regulations and rules of each respective district.

CHAPTER 2

FEATURES

The LTP1245 Line Thermal Printer Mechanism is a compact, high-speed thermal line dot printing mechanism. It can be used with a measuring instrument and analyzer, a POS, a communication device, or a data terminal device.

Since the LTP1245 Line Thermal Printer Mechanism can be battery driven, it can easily be mounted onto a portable device such as a hand-held terminal.

The LTP1245 has the following features:

- **Uses a 5 V power supply or battery power supply**
The voltage used to drive the thermal head is equal to the logic voltage, or is driven by a 5 V single power line.
The range of operating voltage is wide, so four to six Ni-Cd batteries or Ni-MH batteries can also be used. Two Lithium-ion batteries can be used.
- **Compact and light**
The mechanism is compact and light: 72 mm in width, 39.5 mm in depth, 16 mm in height, and approximately 45 g in weight.
- **High resolution printing**
A high-density print head of 8 dots/mm produces clear and precise printing.
- **Longevity**
The mechanism is a maintenance-free device with a long life of 50 km print length and/or 100 million pulses. (Coupling with recommended thermal paper.)
- **High speed printing**¹
A maximum print speed of 200 dot lines per second (25 mm per second) at 5 V, 450 dot lines per second (56.25 mm per second) at 7.2 V, and 500 dot lines per second (62.5 mm per second) at 8.0 V is attainable.
- **Low current consumption**
The printer can be driven on low discharge current lithium-ion batteries.
- **Paper loading path**²
Two systems of paper loading path are provided, curl path and straight path, and the straight path allows thick paper to be printed.
- **Low noise**
Thermal line dot printing is used to guarantee low-noise printing.

- **Automatic paper load**
The paper detector enables the LTP1245 to load paper automatically.
- **Paper feed knob**²
The paper feed knob for manual paper feed is optionally attached depending on the specification. It is selectable according to the applications.
- **Thermal head cleaning**
Move the head up lever to open position to clean the thermal head.

¹ Print speed differs depending on working and environmental conditions.

² The paper loading paths (curl path and straight path) and the presence of paper feed knob are optionally set in the factory.
Please consult our sales representative when ordering them.

CHAPTER 3
SPECIFICATIONS

3.1 GENERAL SPECIFICATIONS

Table 3-1 General Specifications

Item	Specification
Print method	Thermal dot line printing
Dots per line	384 dots
Resolution	8 dots/mm
Print width	48 mm
Maximum printing speed	200 dot lines/s (25.0 mm/s) (at 5 V) ¹ 450 dot lines/s (56.25 mm/s) (at 7.2 V) ¹ 500 dot lines/s (62.5 mm/s) (at 8.0 V) ¹
Paper feed pitch	0.125 mm
Head temperature detection	Via thermistor
Head-up detection	Via photo interrupter
Out-of-paper detection	Via photo interrupter
Operating voltage range V _P line (for head and motor drive) V _{dd} line (for head logic)	4.2 V to 8.5 V ² (equivalent to four through six Ni-Cd or Ni-MH batteries, or two lithium-ion batteries) 4.5 V to 5.5 V
Current consumption For driving the head (V _P) For driving the motor (V _P) For head logic (V _{dd})	Average: 1.5 A (at 5 V), 2.2 A (at 7.2 V), 2.6 A (at 8.5 V) ³ Maximum: 1.6 A (at 5 V), 2.3 A (at 7.2 V), 2.7 A (at 8.5 V) ³ Maximum 0.46 A Maximum 0.01 A

Table 3-1 General Specifications (Continued)

Item	Specification
Operating temperature range (No condensation)	-30°C to 70°C ⁴
Storage temperature range (No condensation)	-35°C to 75°C
Life span (at 25°C and rated energy) Activation pulse resistance Abrasion resistance	100 million pulses or more (print ratio=12.5%) ⁵ 50 km or more (excluding damage due to an alien substance such as rubbish)
Paper width	58 ⁰ ₋₁ mm
Paper feeding force	0.49 N (50 gf) or more
Paper holding force	0.78 N (80 gf) or more
Dimensions (width×depth×height)	72 × 39.5 × 16 mm (excluding head up lever)
Weight	Approximately 45 g
Recommended thermal paper	⁶ -5°C to 50°C <ul style="list-style-type: none"> • TF50KS-E2D (Normal thermal paper) from Nippon Paper Industries • AF50KS-E (Normal thermal paper) from Jujo thermal Ltd. • KT55F20 (Normal thermal paper) from Koehler AG • F5041 (Normal thermal paper) from Mitsubishi Hitec Paper • TL69KS-HG76 (label paper) ⁷ from Nippon Paper Industries -30°C to 70°C <ul style="list-style-type: none"> • TL51KS-R2 (High heat-resistant paper) from Nippon Paper Industries • TL69KS-R2 (High heat-resistant paper) from Nippon Paper Industries 5°C to 40°C <ul style="list-style-type: none"> • TW80KK-S (2-ply thermal paper) ^{5, 7} from Nippon Paper Industries

¹ The maximum printing speed is attained, for example, in the following case:

Driving voltage 8.0V, head temperature over 10°C, and simultaneously activated dot number within 64 dots

² At the operating temperature below -5°C, the printing of 7.0V or less (Vp) becomes light.

³ Given when simultaneously activated dot number is 64 dots during head driving.

⁴ Do not perform continuous printing for more than 5 minutes at the temperature over 50°C.

In out of temperature range -5 to 50°C, drive the head in the fixed 2-division driving mode.

At the temperature below -20°C, thermal agent may attach to the head. In such a case, clean the head.

⁵ In the case of thermal copying paper, the printing is executed in the 2 pulses/1 dot mode, and therefore the printing corresponds to 50 million dots line.

⁶ If printing in other than this range, the printing may blur or become light.

⁷ Not be used in a curled path (LTP1245R, S).

3.2 HEAT ELEMENT DIMENSIONS

The LTP1245 contains a thermal head with 384 heat elements (dot-size).

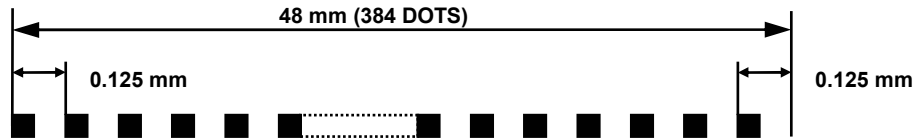

Figure 3-1 Heat Element Dimensions

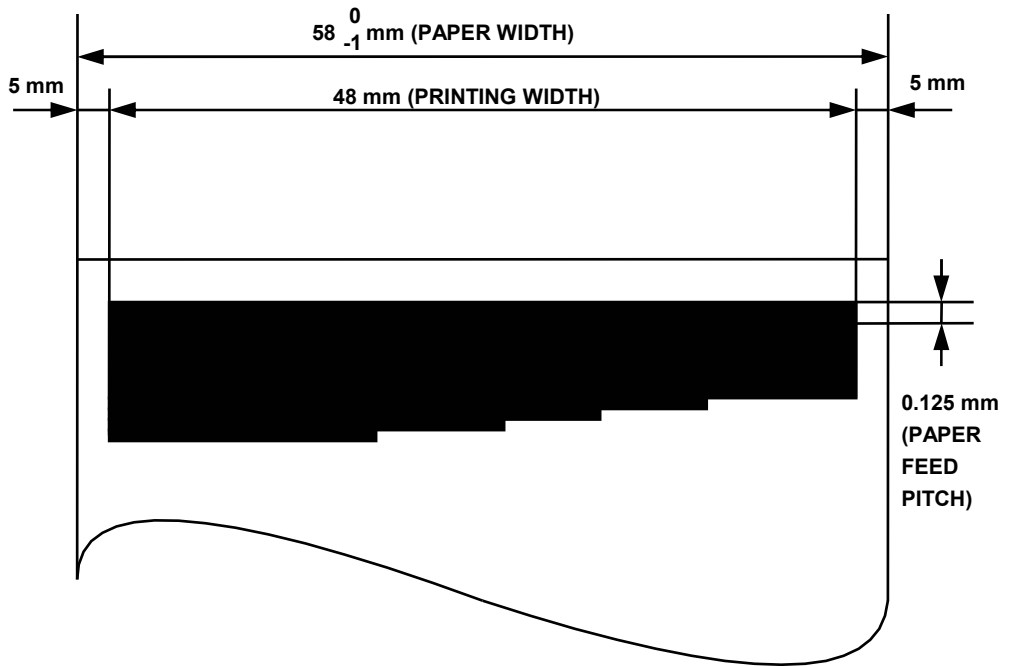

Figure 3-2 Print Area

3.3 PAPER FEED CHARACTERISTICS

- Paper is fed in a forward direction when the motor shaft is rotating in the normal direction (clockwise) when seen from the motor gear side.
- The motor is driven by a 2-2 phase excitation, constant current chopper method and feeds paper by 0.125 mm (equivalent to a single dot pitch) every two steps of the motor drive signal.
- To prevent deterioration in printing quality due to backlash of the paper feed system, the motor should be driven 40 steps in a reverse direction then 40 steps in the normal direction during initialization or following backward feeding.
- During paper feeding, the motor should be driven lower than the value obtained by equation (1).

When at - 5°C or higher:
Equation (1):

$$V_p \times 165 - 220 \text{ (pps) (max.1000 (pps))}$$

When at lower than 5°C:

$$300 \text{ (pps)}$$

- During printing, motor drive frequency should be adjusted according to working conditions such as voltage, temperature, number of activated dots, etc. (For details, see **CHAPTER 5 DRIVE METHOD.**)
- Drive the motor at 200 pps when automatically loading paper, regardless of the voltage. As for the motor current value, to keep the motor torque, activate the motor by only the first setting current value (i.e. one current) for the entire motor drive step time. (See **Chapter 3.4.3 Precautions for Driving the Motor.**)
- It is not possible to print while the motor is rotating in a reverse direction.

Table 3-2 Sample Motor Drive Frequency

Operating Voltage	Drive Frequency when feeding paper	Drive Frequency when automatically loading paper
4.2 V	473 pps	200 pps
5 V	605 pps	200 pps
6 V	770 pps	200 pps
7.2 V	968 pps	200 pps
8 V	1000 pps	200 pps
8.5 V	1000 pps	200 pps

3.4 STEP MOTOR CHARACTERISTICS

Table 3-3 General Motor Specifications

Item	Specification
Type	PM
Number of phases	4-phase
Drive method	Bipolar chopper
Excitation	2-2 phase
Winding resistance per phase	14 Ω \pm 10%
Rated voltage	4.2 - 8.5 V
Rated current	0.23 A/phase, 0.15 A/phase ¹
Maximum current consumption	0.46 A
Drive frequency	50 - 1000 pps (according to drive voltage)

¹ See 3.4.3 Precautions for Driving the Motor.

When at lower than - 5°C, the motor is driven at 0.23 A/phase only.

3.4.1 Motor Drive Circuit

(1) Sample Drive Circuit

Sample drive circuit for the motor are shown in **Figure 3-3**.

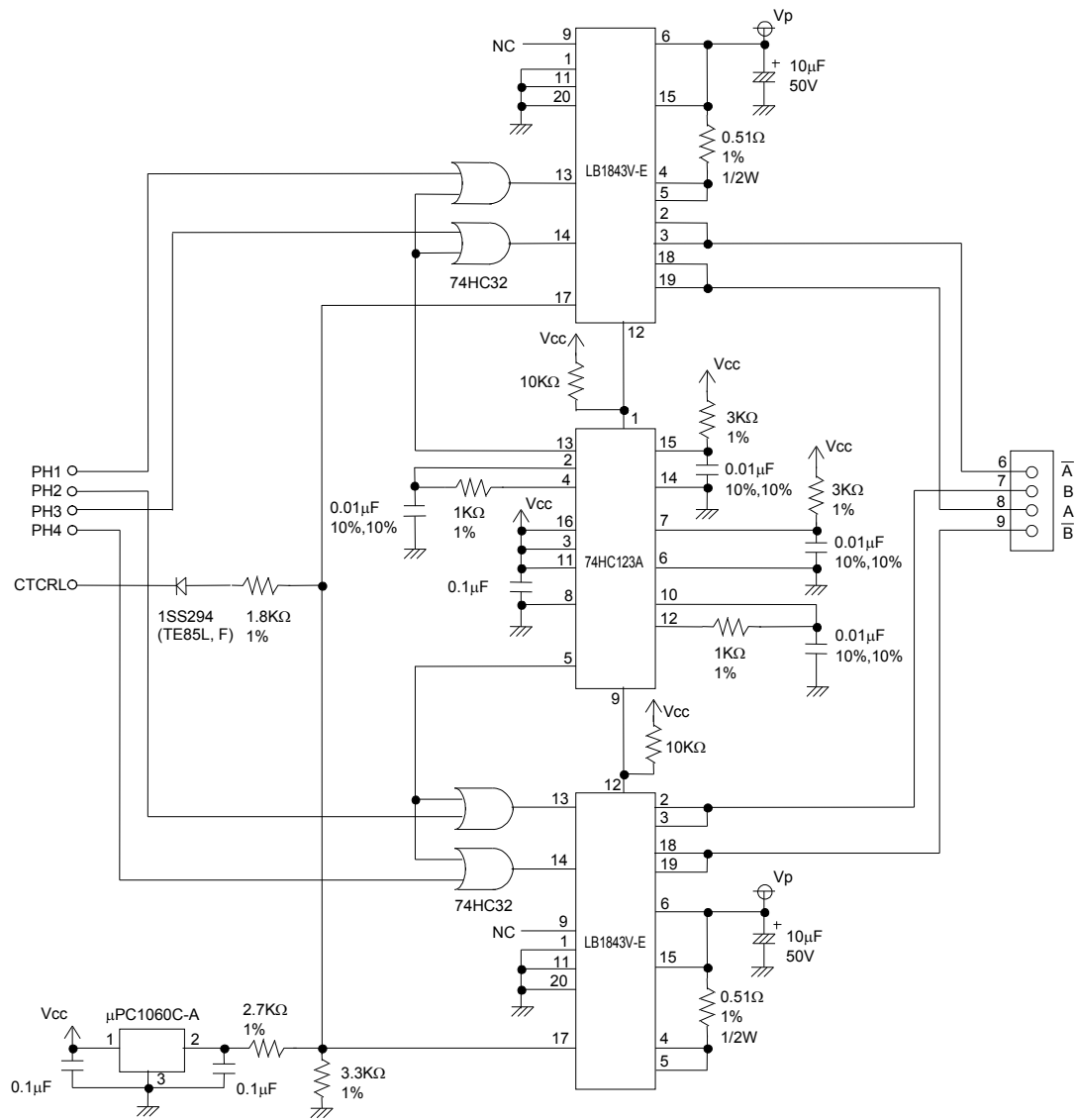

Figure 3-3 Sample Drive Circuit (Motor)

(2) Excitation Sequence

As shown in **Table 3-4**, the LTP1245 feeds paper in the normal direction when the motor is excited in the order of step 1, step 2, step 3, step 4, step 1, step 2, On the other hand, to rotate the motor in a reverse direction, drive the motor in the reverse order of: step 4, step 3, step 2, step 1, step 4, step 3,

Table 3-4 Excitation Sequence

Signal Name	Sequence			
	Step 1	Step 2	Step 3	Step 4
\overline{A}	Low	High	High	Low
B	High	High	Low	Low
A	High	Low	Low	High
\overline{B}	Low	Low	High	High

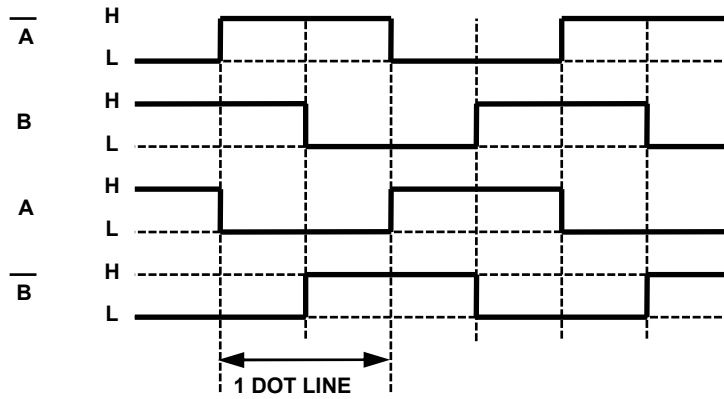

Figure 3-4 Input Voltage Signals for the Sample Drive Circuit (Motor)

3.4.2 Motor Timing

Refer to the timing chart in **Figures 3-5 and 3-6** when designing the control circuit or software for starting and stopping the motor. Also take note of the following precautions:

Precautions for Designing the Motor Control Circuit and Software

(1) Stop step

- To stop the motor, excite for a single step period with a phase that is the same as the last one in the printing step.

(2) Pause state

- In the pause state, do not excite the step motor in order to prevent the motor from heating. Even when the step motor is not excited, it maintains a holding force to prevent paper from sliding.

(3) Start step

- To restart the motor from the stop step, immediately shift the motor into the printing sequence.
- To restart the motor from the pause (no excitation) state, shift the motor into the printing sequence after outputting a phase that is the same as that of the stop step for a single step.

When using the Sample Drive Circuit (Motor) :

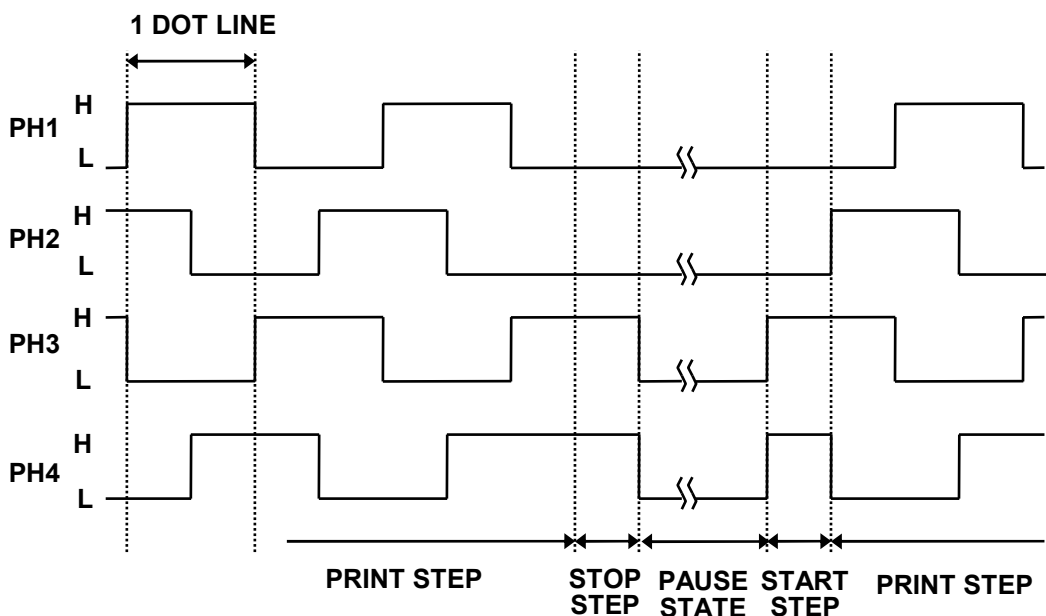

Figure 3-5 Motor Start/Stop Timing (Sample Drive Circuit (Motor))

(4) Others

- Do not print paper at the intermittent feed mode. Doing so may deteriorate the printing quality due to irregular paper feeding pitch.
- To print characters and bit images, always follow the start step and stop step.

3.4.3 Precautions for Driving the Motor

(1) Motor Current Control

Low speed motor driving while printing due to a division drive method, print data, and input data transfer speed may cause noise or print trouble to occur due to over torquing or overheating of the motor. To prevent these from occurring, be sure to set the motor current as follows and perform two-current control.

Activate the motor with the 1st setting current in each motor drive step. Change the activation current to the 2nd setting current after activating the motor with the 1st setting current for T1.

T1 is defined from each period of the motor drive step and Vp voltage as follows:

How to define T1 (unit: μ s)

When Vp is under 7.2 V :

T1: Compare the following two values and adopt the smaller one.
(Each period of the motor drive step - 500) and 925.9

When Vp is 7.2 V or more :

T1: Compare the following two values and adopt the smaller one.
(Each period of the motor drive step - 500) and $(1000000 / (3600 - Vp \times 350))$

In use at temperature below -5°C, Control the 0.23(A) at 1st current.

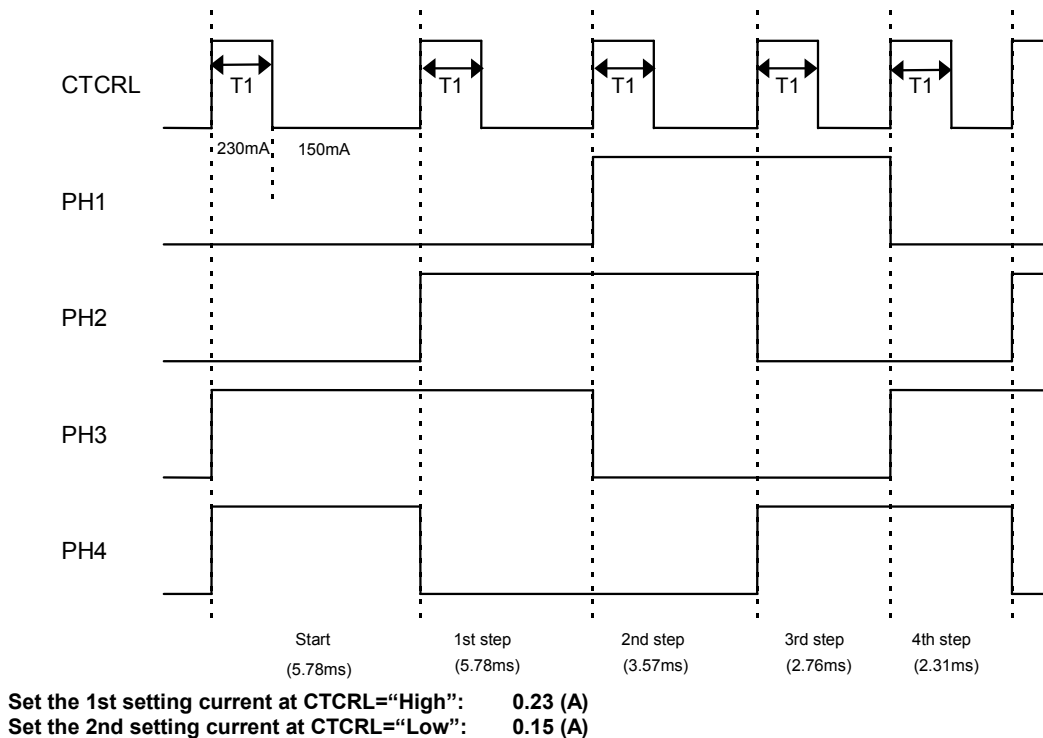

Figure 3-6 Motor Drive Timing Chart (in use at temperature over -5°C)

In use at temperature below -5°C

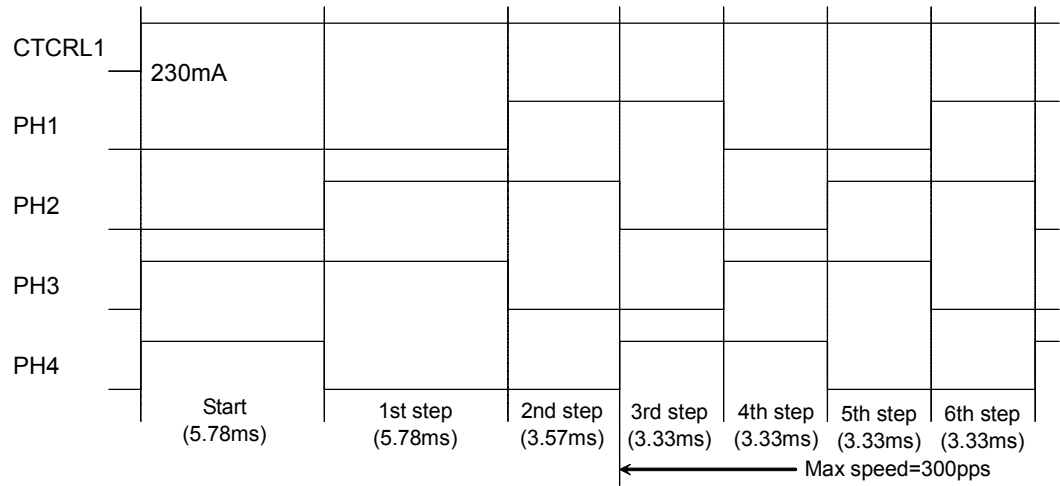

Figure 3-7 Motor Drive Timing Chart (in use at temperature below -5°C)

(2) Acceleration Control

When driving the motor, acceleration control is needed to start paper feeding. When the motor is to be driven at the motor drive frequency that is calculated using equation (1), the motor may come out of step under heavy load.

Drive the motor to the maximum driving speed that is calculated using equation (1), according to the linear acceleration table in **Table 3-5**.

The method for accelerating the motor is as follows:

1. Output start step (5780 (μs)).
2. Output first step for the first acceleration step time
3. Output second step for the second acceleration step time
4. Output n^{th} step for the n^{th} step acceleration time
5. After outputting the time calculated using equation (1), the motor is driven at a constant speed.

The printer can print during acceleration.

Set the maximum drive speed to 300 pps (3333 μs) for printing at lower than -5°C .

When accelerating it again after decreasing the speed, follow the method shown below.

When the step time is T_m (the reciprocal number of the frequency calculated using equation (1)), compare T_m with the time that was taken in the previous step.

- (1) In case $T_m >$ time that was taken in the previous step (i.e. decreasing speed)
the closest acceleration step time to T_m and the acceleration step time that is larger than T_m , are output.
- (2) In case $T_m <$ time that was taken in the previous step (i.e. reacceleration time)
the next closest acceleration step time to the previous step time or T_m , which is longer, is output.

Table 3-5 Acceleration Steps

Number of Steps	Speed (pps)	Step Time (μs)
start	—	5780
1	173	5780
2	280	3571
3	362	2762
4	432	2314
5	493	2028
6	547	1828
7	597	1675
8	644	1553
9	687	1456
10	728	1374
11	768	1302
12	805	1242
13	840	1191
14	874	1144
15	907	1103
16	939	1065
17	970	1031
18	1000	1000

3.5 THERMAL HEAD

3.5.1 Structure of the Thermal Head

As **Figure 3-8** shows, the LTP1245 thermal head consists of 384 heat elements, and heat element drivers.

Serial printing data input from the DAT terminal is transferred to the shift register synchronously with the CLK signal, then stored in the latch register with the timing of the LATCH signal.

Inputting the head activation signal (DST 1 to 6) activates heat elements in accordance with the printing data stored in the latch register.

A maximum of six division printing is available for the LTP1245.

Table 3-6 shows the relationship between DST signals and heat elements.

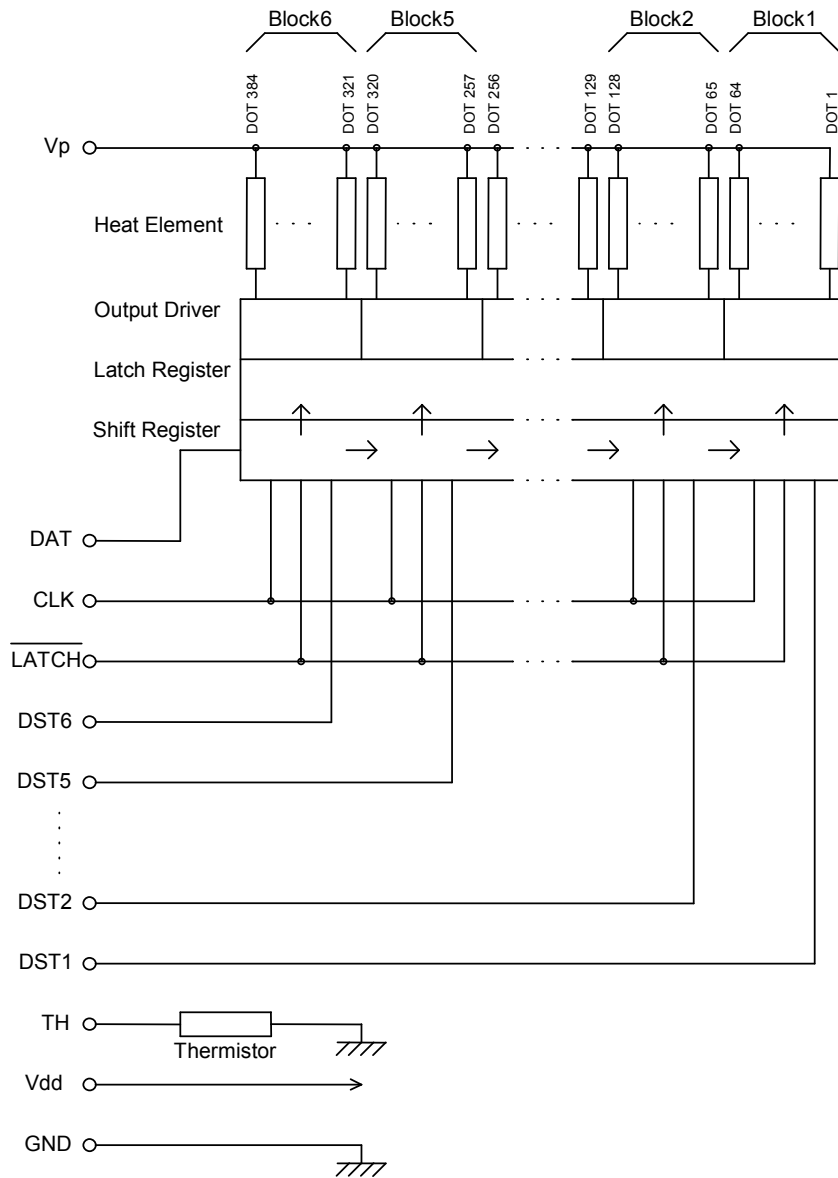

Figure 3-8 Thermal Head Block Diagram

Table 3-6 Blocks and Activated Heat Elements

Block Number	Heat Element Number	Dots / Block
1	1 - 64	64
2	65 - 128	64
3	129 - 192	64
4	193 - 256	64
5	257 - 320	64
6	321 - 384	64

3.5.2 Printed Position of the Data

Data dots from 1 to 384 which are transferred through DAT are printed as shown in **Figure 3-9**.

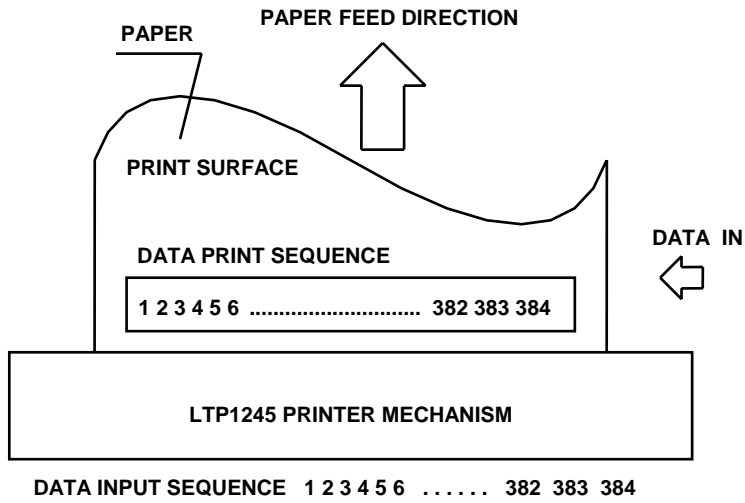

Figure 3-9 Printed Position of the Data

3.5.3 Head Resistance

The LTP1245 head resistance is $176 \Omega \pm 4 \%$.

3.5.4 Head Voltage

The LTP1245 has a built-in head driver IC and control IC. **Table 3-7** shows the head voltage.

Table 3-7 Head Voltage

Item		Voltage Range
Head drive voltage	Vp	4.2 to 8.5 V
Head logic voltage	Vdd	4.5 to 5.5 V

3.5.5 Peak Current

Since the peak current (maximum current) may reach the values calculated using equation (2) when the thermal head is driven, make sure that the allowable current for the cable material and the voltage drop on the cables are well within the specified range.

Equation (2):

$$I_p = \frac{N \times V_p}{R_H}$$

- I_p: Peak current (A)
- N: Number of dots that are driven at the same time
- V_p: Head drive voltage (V)
- R_H: Head resistance (Ω)

3.5.6 Thermal Head Electrical Characteristics

Table 3-8 Thermal Head Electrical Characteristics

(Vdd=4.5 to 5.5V, Ta=0 to 50°C)

Item	Symbol	Conditions	Rated			Unit	
			MIN	TYP	MAX		
Head resistance	RH		169	176	183	Ω	
Head drive voltage	Vp		4.2	-	8.5	V	
Head drive current	Ip	Vp=8.5 V, max. simultaneously activated dot "64"	2.5	2.6	2.7	A	
Logic block voltage	Vdd		4.5	5.0	5.5	V	
Logic block current	Idd	Ta=25°C	Waiting for activation	-	-	0.5	mA
			fclk=4MHz,DAT=fixed	-	-	6	mA
			fclk=4MHz,DAT=1/2fclk	-	-	10	mA
"High" input voltage	Vih	CLK,DAT,LATCH,DST	0.8×Vdd	-	Vdd	V	
"Low "input voltage	Vil	CLK,DAT,LATCH,DST	0	-	0.2×Vdd	V	
"High"input current	CLK	Iih	Ta=25°C Vdd=5.0(V) Vih=5.0(V)	-	-	3	μA
	DAT			-	-	0.5	μA
	LATCH			-	-	3	μA
	DST			-	-	55	μA
"Low "input current	CLK	Iil	Ta=25°C Vdd=5.0(V) Vil=0(V)	-	-	-3	μA
	DAT			-	-	-0.5	μA
	LATCH			-	-	-3	μA
	DST			-	-	-0.5	μA
Driver leak current	Ileak	Vp=7(V), for 1 bit	-	-	1.0	μA	
CLK frequency	fclk		-	-	4	MHz	
CLK pulse width	t1	See the Timing Chart	80	-	-	ns	
DAT setup-time	t2	See the Timing Chart	50	-	-	ns	
DAT hold time	t3	See the Timing Chart	50	-	-	ns	
LATCH setup time	t4	See the Timing Chart	120	-	-	ns	
LATCH pulse width	t5	See the Timing Chart	120	-	-	ns	
LATCH hold time	t6	See the Timing Chart	120	-	-	ns	
DST setup time	t7	See the Timing Chart	120	-	-	ns	

3.5.7 Timing Chart

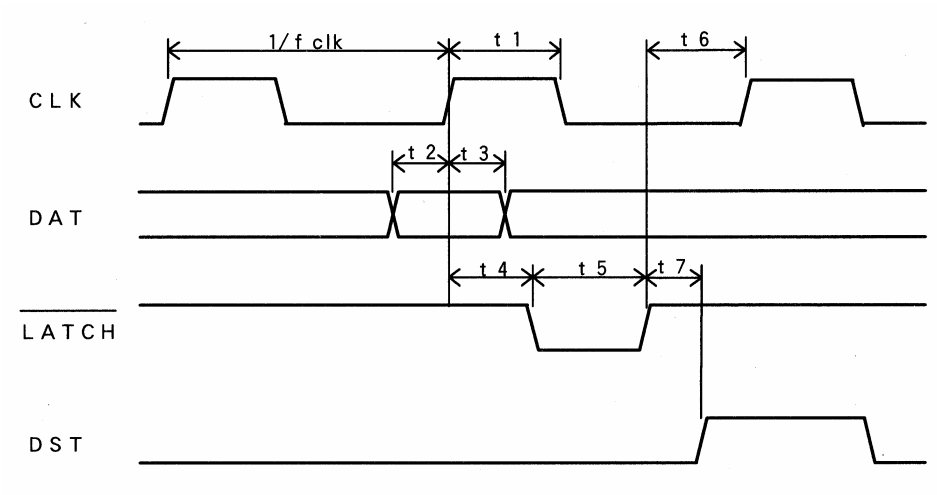

Figure 3-10 Timing Chart

3.6 CONTROLLING THE HEAD ACTIVATION (DST) PULSE WIDTH

3.6.1 Calculation of Head Activation Pulse Width

Head activation pulse width is calculated using the following equation (3).

To execute high quality printing using the LTP1245, the value that is calculated using the following equation (3) must be adjusted according to the printer's installation environment. Calculate each value used according to the steps in **Sections 3.6.2 to 3.6.6** and apply the pulse width with the t value that is obtained by substituting each value into the equation (3).

Printing using too high voltage or too long pulse width may shorten the life of the thermal head.

Equation (3):

$$t = \frac{E \times R}{V^2} \times C$$

t :	Head pulse width (ms)	
E :	Standard applied energy (mJ)	See Section 3.6.2.
V :	Applied voltage (V)	See Section 3.6.3.
R :	Head resistance (Ω)	See Section 3.6.4.
C :	Head pulse term coefficient	See Section 3.6.6.

3.6.2 Calculation of Applied Energy

Applied energy should be in accordance with the temperature of the thermal head and the printer's installation environment

The thermal head has a built-in thermistor. Measure the temperature using thermistor resistance. Standard applied energy is based on using the recommended thermal paper (59 μm) and a temperature of 25°C. Calculate the printing energy using equation (4) and the paper coefficient and temperature coefficient.

Equation (4):

$$E = (0.285 - T_C \times (T_X - 25)) \times P$$

T_X :	Detected temperature using the thermistor ($^{\circ}\text{C}$) ¹	
P :	Thermal paper coefficient	
	Normal thermal paper	1.0
	TL69KS-HG76 (label paper)	1.35
	TL69KS-R2 (90 μm paper)	1.5
	TL51KS-R2 (62 μm paper)	1.5
	TW80KK-S (2-ply paper)	2.4 ²
T_C :	Temperature coefficient	
	TL69KS-R2	0.00285
	TL51KS-R2	0.00285
	TW80KK-S	0.0037
	Other thermal papers	0.003135

¹ The thermistor resistance value at T_X ($^{\circ}\text{C}$). See **Section 3.6.8.**

² For driving for 2-ply thermal paper, see **Section 3.6.9.**

3.6.3 Adjustment of Head Activation Voltage

Adjustment of head activation pulse width due to changing the head activation voltage is to be in accordance with equation (5). The adjustment method differs if the head drive voltage (V_p) is 5.5 V or more or under 5.5 V.

If head temperature is above -5°C

Equation (5):

$$\begin{aligned} & (5.5 \text{ V or more}) \\ & V = V_p \times 1.2 - 1.8 \\ & (\text{under } 5.5 \text{ V}) \\ & V = V_p \times 1.4 - 2.9 \end{aligned}$$

V_p : Head activation voltage (V)

If head temperature is below -5°C

$$\text{More than } 5.5\text{V} \quad : V = V_p \times 1.2 - 1.8 + T \times 0.01$$

$$\text{Less than } 5.5\text{V} \quad : V = V_p \times 1.4 - 2.9 + T \times 0.01$$

T: Thermistor detection temperature ($^{\circ}\text{C}$)

3.6.4 Adjustment of Head Resistance

Adjustment of head resistance is to be in accordance with equation (6). Due to wiring resistance there is a drop in voltage.

Equation (6):

$$R = \frac{(RH + 25 + (R_C + r_C) \times N)^2}{RH}$$

RH: Head resistance 178.5 (Ω)

25: Wiring resistance in the thermal head (Ω)

R_C : Common terminal wiring resistance in the thermal head: 0.1 (Ω)

r_C : Wiring resistance between V_P and GND (Ω)¹

N: Number of dots driven at the same time

¹ This resistance is the resistance of the wire used between the FFC terminal of thermal head, the power supply, the resistance of switching circuit of relay, etc.

3.6.5 Determination of Activation Pause Time and Activation Pulse Period

Dot lines may be activated in succession to the same thermal dot in order to protect thermal head elements. Determine the activation period (the time from the preceding activation start to the current activation start) which conforms to equation (7) to reserve the pause time.

Equation (7):

$$W > t + 0.5(\text{ms})$$

W : Activation period of 1-dot line (ms)

3.6.6 Head Activation Pulse Term Coefficient

Make adjustments using the head activation pulse term coefficient (motor drive frequency or equivalent) as the printing density changes by the printing speed.

According to equations (8), calculate compensation coefficient C of the heat pulse.

Equation (8):

$$C = 1 - 1.15/(1.9+W)$$

W = 2000 / motor drive frequency

3.6.7 Calculation Sample for the Head Activation Pulse Width

Table 3-9 displays the calculation sample of the head activation pulse width that was calculated using equation (3) and the values obtained using equations (4) to (8).

Table 3-9 Activation Pulse Width

Head Drive Voltage (V)	Thermistor Temperature °C	Motor Drive Frequency (PPS)									
		100	200	300	400	500	600	700	800	900	1000
4.2	0	9.92									
	10	9.07									
	20	8.21									
	30	7.35									
	40	6.50									
	50	5.64									
	60	4.79	4.56								
	70	3.93	3.75								
	80	3.07	2.93	2.81							
5.0	0	5.24	5.00								
	10	4.79	4.57								
	20	4.34	4.14								
	30	3.89	3.70								
	40	3.43	3.27	3.14							
	50	2.98	2.84	2.72							
	60	2.53	2.41	2.31	2.22						
	70	2.08	1.98	1.90	1.83	1.76					
	80	1.62	1.55	1.48	1.43	1.38	1.34				
6.0	0	3.02	2.88	2.76							
	10	2.76	2.63	2.52	2.43						
	20	2.50	2.38	2.28	2.20						
	30	2.24	2.14	2.05	1.97	1.90					
	40	1.98	1.89	1.81	1.74	1.68	1.63				
	50	1.72	1.64	1.57	1.51	1.46	1.42	1.38			
	60	1.46	1.39	1.33	1.28	1.24	1.20	1.17			
	70	1.20	1.14	1.09	1.05	1.02	0.99	0.96			
	80	0.94	0.89	0.86	0.82	0.80	0.77	0.75			
7.2	0	1.88	1.80	1.72	1.66	1.60	1.55				
	10	1.72	1.64	1.57	1.51	1.46	1.42	1.38			
	20	1.56	1.49	1.42	1.37	1.32	1.28	1.25	1.21		
	30	1.40	1.33	1.28	1.23	1.19	1.15	1.12	1.09	1.06	
	40	1.23	1.18	1.13	1.08	1.05	1.02	0.99	0.96	0.94	
	50	1.07	1.02	0.98	0.94	0.91	0.88	0.86	0.83	0.81	
	60	0.91	0.87	0.83	0.80	0.77	0.75	0.73	0.71	0.69	
	70	0.75	0.71	0.68	0.66	0.63	0.61	0.60	0.58	0.57	
	80	0.58	0.56	0.53	0.51	0.50	0.48	0.47	0.45	0.44	
8.0	0	1.45	1.38	1.32	1.27	1.23	1.19	1.16	1.13	1.10	
	10	1.32	1.26	1.21	1.16	1.12	1.09	1.06	1.03	1.01	0.98
	20	1.20	1.14	1.10	1.05	1.02	0.99	0.96	0.93	0.91	0.89
	30	1.07	1.02	0.98	0.94	0.91	0.88	0.86	0.84	0.82	0.80
	40	0.95	0.90	0.87	0.83	0.81	0.78	0.76	0.74	0.72	0.71
	50	0.82	0.79	0.75	0.72	0.70	0.68	0.66	0.64	0.63	0.61
	60	0.70	0.67	0.64	0.61	0.59	0.58	0.56	0.54	0.53	0.52
	70	0.57	0.55	0.52	0.50	0.49	0.47	0.46	0.45	0.44	0.43
	80	0.45	0.43	0.41	0.39	0.38	0.37	0.36	0.35	0.34	0.33
8.5	0	1.25	1.19	1.14	1.10	1.06	1.03	1.00	0.97	0.95	0.93
	10	1.14	1.09	1.04	1.00	0.97	0.94	0.91	0.89	0.87	0.85
	20	1.03	0.99	0.94	0.91	0.88	0.85	0.83	0.81	0.79	0.77
	30	0.93	0.88	0.85	0.81	0.79	0.76	0.74	0.72	0.70	0.69
	40	0.82	0.78	0.75	0.72	0.69	0.67	0.65	0.64	0.62	0.61
	50	0.71	0.68	0.65	0.62	0.60	0.58	0.57	0.55	0.54	0.53
	60	0.60	0.57	0.55	0.53	0.51	0.50	0.48	0.47	0.46	0.45
	70	0.49	0.47	0.45	0.44	0.42	0.41	0.40	0.39	0.38	0.37
	80	0.39	0.37	0.35	0.34	0.33	0.32	0.31	0.30	0.29	0.29

Note) The above table shows values for the 59 μm recommended thermal paper (TF50KS-E2D), Rc+rc=0.16 Ω, and N=64. In the shaded area, the drive pulse width exceeds the allowable activation pulse width or the activation pulse width exceeds the motor drive frequency. Therefore, use the motor drive frequency shown in the unshaded area.

3.6.8 Thermistor Resistance

The resistance of the thermistor at the operating temperature T_x ($^{\circ}\text{C}$) is determined using the following equation (10).

Equation (10):

$$R_x = R_{25} \times \text{EXP} \left\{ B \times \left(\frac{1}{273 + T_x} - \frac{1}{298} \right) \right\}$$

- R_x : Resistance at operating temperature T_x ($^{\circ}\text{C}$)
- R_{25} : $15 \text{ k}\Omega \pm 10\%$ (25°C)
- B : $3440 \text{ K} \pm 3\%$
- T_x : Operating temperature ($^{\circ}\text{C}$)
- EXP (A): The Ath power of natural logarithm e (2.71828)

[Rating]

Operating temperature range: -40°C to $+125^{\circ}\text{C}$

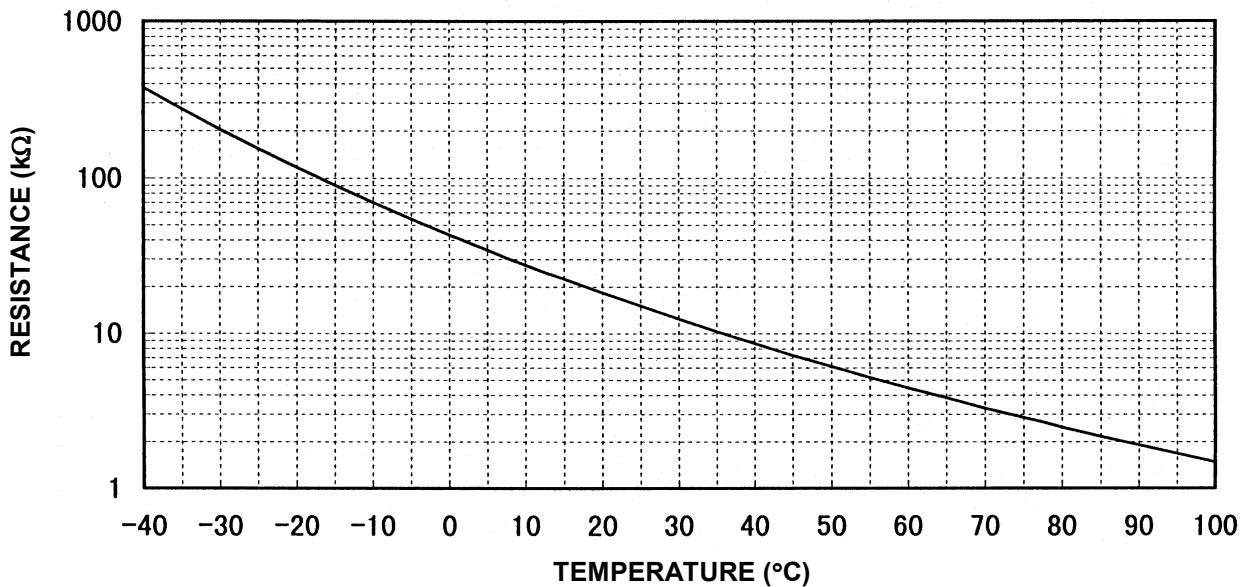

Figure 3-11 Thermistor Resistance vs. Temperature

Table 3- 10 Temperature and Corresponding Thermistor Resistance

Temperature (°C)	Thermistor Resistance (kΩ)	Temperature (°C)	Thermistor Resistance (kΩ)
-40	375.54	40	8.63
-35	275.39	45	7.26
-30	204.55	50	6.14
-25	153.76	55	5.22
-20	116.89	60	4.46
-15	89.82	65	3.83
-10	69.71	70	3.30
-5	54.61	75	2.86
0	43.17	80	2.48
5	34.42	85	2.17
10	27.66	90	1.90
15	22.40	95	1.67
20	18.27	100	1.47
25	15.00		
30	12.40		
35	10.31		

3.6.9 How to Print Using 2-ply Thermal Paper

For fine printing, drive the thermal elements two times at half of the drive pulse that was calculated using equation (3) in **Section 3.6.1**.

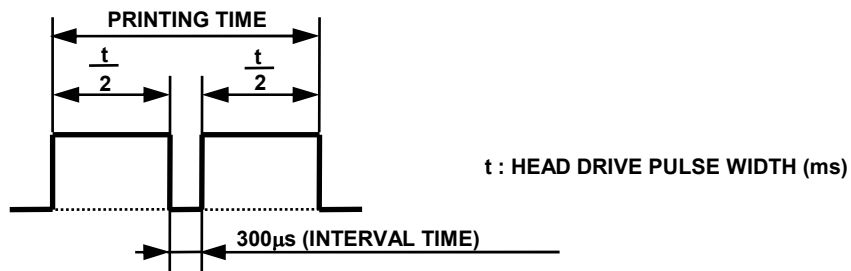

Figure 3-12 How to Drive 2-ply Thermal Paper

3.6.10 Detecting Abnormal Temperatures of the Thermal Head

To protect the thermal head and to ensure personal safety, abnormal thermal head temperatures must be detected by both hardware and software as follows:

- **Detecting abnormal temperatures by software**

Design software that will deactivate the heat elements if the thermal head thermistor (TH) detects a temperature higher than 80 °C (thermistor resistance $R_{TH} \leq 2.48 \text{ k}\Omega$), and reactivate the heat elements when a temperature lower than 60 °C ($R_{TH} \geq 4.46 \text{ k}\Omega$) is detected. If the thermal head continues to be activated at a temperature higher than 80 °C, the life of the thermal head may be shortened significantly.

- **Detecting abnormal temperatures by hardware**

If the control unit (CPU) malfunctions, the software for detecting abnormal temperatures may not function properly, resulting in overheating of the thermal head. Overheating of the thermal head may cause damage to the thermal head or cause skin burns.

Always use hardware in conjunction with software for detecting abnormal temperatures to ensure personal safety. (If the control unit malfunctions, it may be impossible to prevent damage to the thermal head even if a detection of abnormal temperature is detected by hardware.)

Using a window comparator circuit or similar detector, design hardware that detects the following abnormal conditions:

- (a) Overheating of the thermal head (approximately 100 °C or higher ($R_{TH} \leq 1.47 \text{ k}\Omega$)).
- (b) Faulty thermistor connection (the thermistor may be open or short-circuited).

If (a) and (b) are detected, immediately deactivate the heat elements. Reactivate the heat elements after they have returned to normal.

3.7 HEAD-UP/PAPER DETECTOR

LTP1245 has a built-in head-up detector to detect whether the head is up or down and a paper detector to detect whether paper is present or exhausted.

Both detectors are reflection photo interruptors which are designed to output signals as shown in **Table 3-11** according to their status.

The external circuit should be designed so that it detects output from the head-up and paper detector and does not activate the thermal head when the head is in the up position and paper is exhausted. If the thermal head is activated in the head up position, the thermal head may be damaged or the life of the head may be shortened significantly. If the thermal head is activated in an out-of paper mode, the thermal head and platen roller may be damaged.

Table 3-11 Detector's Status and Output Signals

Detector	Status	Output signal
Head up detector	Head down	"Low"
	Head up	"High"
Paper detector	Paper exist	"Low"
	No paper	"High"

* Sensing by the head up detector is delayed from the actual completion of the head up/down action.

3.7.1 General Specifications

Table 3-12 Absolute Maximum Ratings of Detectors

(at 25°C)

Item		Symbol	Rating
LED (input)	Forward current	I_F	30 mA
	Peak forward current	I_{FM}	0.4 A
	Reverse voltage	V_R	5 V
Phototransistor (output)	Collector-to-emitter voltage	V_{CEO}	30 V
	Emitter-to-collector voltage	V_{ECO}	5 V
	Collector current	I_C	20 mA
	Collector loss	P_C	50 mW
Operating temperature		T_{opr}	-25°C to + 85°C
Storage temperature		T_{stg}	-40°C to + 100°C

Table 3-13 Detectors Input / Output Conditions

Item	Symbol	Conditions	Std.	Max.	
LED (input)	Forward voltage	V_F	$I_F=10\text{mA}$	1.15V	1.3V
	Reverse current	I_R	$V_R=5\text{V}$	-	$10\mu\text{A}$
Photo-transistor (output)	Dark current	I_{CEO}	$V_{CE}=24\text{V}$	-	$0.1\mu\text{A}$
Transfer characteristics	Photo electric current	I_C	$I_F=10\text{mA}, V_{CE}=5\text{V}$	$450\mu\text{A}$	$1100\mu\text{A}$
	Response time (at rise)	t_r	$I_C=1\text{mA}, V_{CE}=10\text{V}$	$10\mu\text{s}$	-
	Response time (at fall)	t_f	$R_L=1\text{k}\Omega, d=1\text{mm}^1$	$10\mu\text{s}$	-
	Leak current	I_{LEAK}	$I_F=10\text{mA}, V_{CE}=5\text{V}$	-	$0.2\mu\text{A}$

¹ d = sensing distance

3.7.2 Sample External Circuit

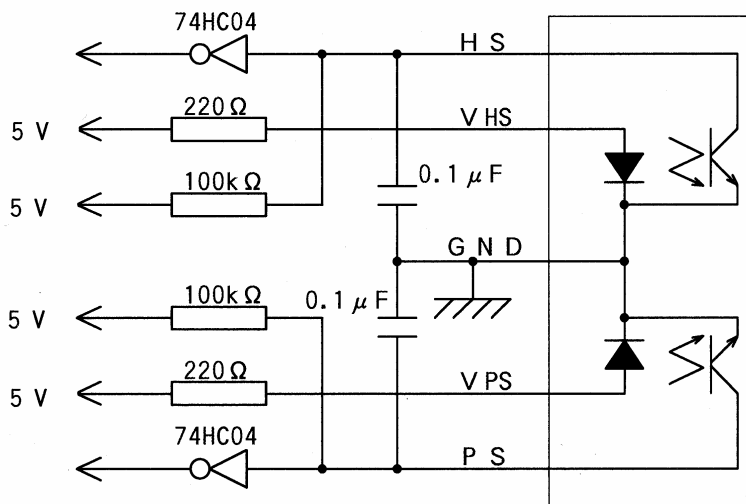

The HS signal is high when the thermal head is in the “up” position.
The PS signal is high when paper is exhausted.

Figure 3-13 Sample External Circuit of the Head-Up/Paper Detector

3.7.3 Automatic Paper Load

Paper can be automatically loaded when used in conjunction with the paper detector. To prevent paper from skewing, cut the edges at right angles in line with the paper feed direction before loading it.

If skewed, feed the paper until it is straight, or place the head in the up position and adjust the paper so that it is fed straight.

Figure 3-13 shows a flowchart for automatically loading paper.

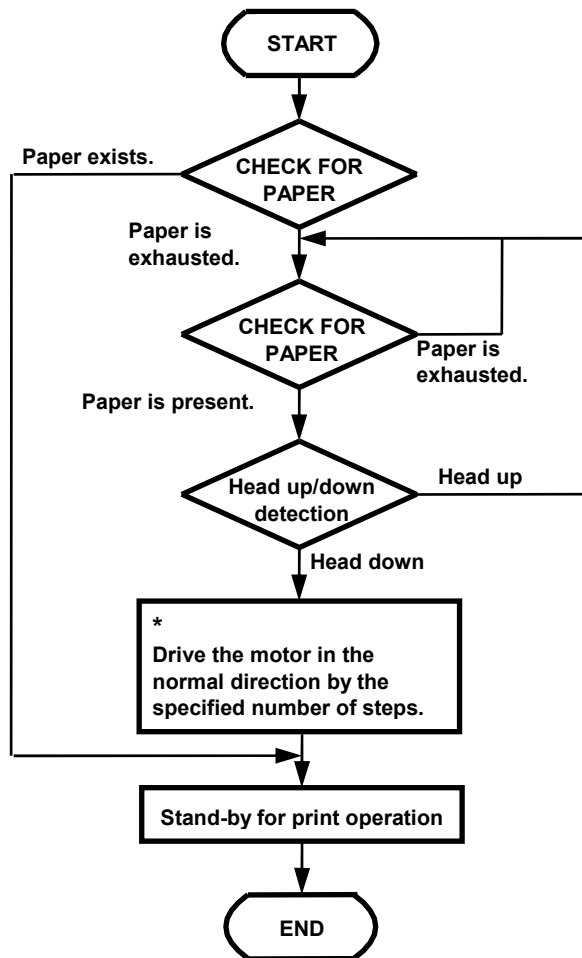

* Drive the motor at lower than the frequency during automatic paper loading described in 3.3 PAPER FEED CHARACTERISTICS.

Set the number of motor drive steps in consideration of:

- Deviation in the force of the rubber roller to catch the paper
- Distance to the paper eject

The distance between the paper detector and the heat elements is approximately 8 mm.

Figure 3-14 Flowchart for Automatic Paper Load

3.8 Mode Code Label

Figure 3-14 shows that the printer is the LTP1245R-C384-E which is made in September 2004. See Figure 7-1 LTP1245R-C384-E Appearance and Dimensions for labeling position.

- (1) Manufactured year: 2004
- (2) Model code: LTP1245R-C384-E
- (3) Manufactured month: September (X: October, Y: November, Z: December)

1	2	3	●	5	6	7	8	9	0					
L	T	P	1	2	4	5	R	-	C	3	8	4	-	E
1	2	3	4	5	6	7	8	●	X	Y	Z			

Figure 3-15 Model Code Label

CHAPTER 4

CONNECTING EXTERNAL CIRCUITS

The LTP1245 has two types of connectors to connect it to the external circuits: FPC (Flexible Printed Cable) type connector and FFC (Flexible Flat Cable) type connector.

Table 4-1 shows the recommended connectors.

Table 4-1 Recommended Connectors

No.	External Circuit Functions	Number of Pins	Recommended Connectors (External Circuit side)
1	Thermal head control	20	Molex Co., Ltd. 52044-2045 (horizontal type) 52045-2045 (vertical type) 5597-20APB7F (horizontal type) 5597-20CPB7F (vertical type)
2	Motor control, paper detection, and head-up detection	9	Molex Co., Ltd. 52030-0919 (vertical type) 52089-0929 (horizontal type)

4.1 THERMAL HEAD CONTROL TERMINALS

Figure 4-1 shows the FFC terminals of the thermal head control.

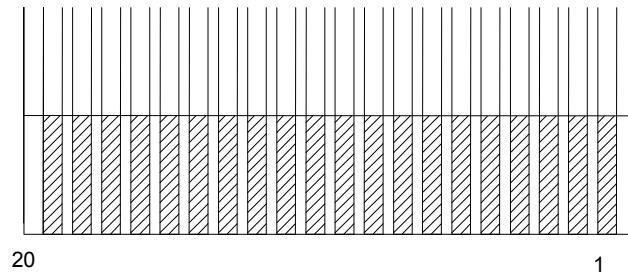

Figure 4-1 Thermal Head Control Terminals (FFC)

Table 4-2 Thermal Head Control Terminal Assignments

Terminal Number	Signal Name	Input/Output	Function
1	Vp	Input	Thermal head drive voltage
2	Vp	Input	Thermal head drive voltage
3	GND	-	GND
4	GND	-	GND
5	GND	-	GND
6	DAT	Input	Print data input (serial input)
7	CLK	Input	Synchronizing signal for data transfer
8	LATCH	Input	Print data latch (memory storage)
9	DST6	Input	Thermal head print activation instruction signal
10	DST5	Input	Thermal head print activation instruction signal
11	DST4	Input	Thermal head print activation instruction signal
12	DST3	Input	Thermal head print activation instruction signal
13	DST2	Input	Thermal head print activation instruction signal
14	DST1	Input	Thermal head print activation instruction signal
15	TH	-	Thermistor
16	Vdd	Input	Logic power supply (5V)
17	GND	-	GND
18	GND	-	GND
19	Vp	Input	Thermal head drive voltage
20	Vp	Input	Thermal head drive voltage

4.2 MOTOR AND DETECTOR TERMINALS

Figure 4-2 shows the FPC terminals of the motor control, paper detector and head-up detector.

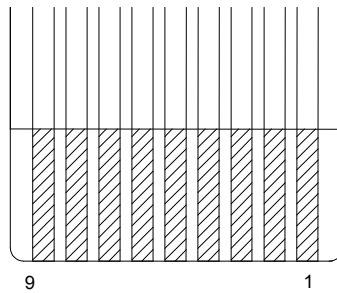

Figure 4-2 Motor and Detector Terminals (FPC)

Table 4-3 Motor and Detector Terminals Assignments

Terminal Number	Signal Name	Function
1	HS	Output signal of the head-up detector (collector output of a photo-transistor)
2	V _{HS}	Power supply of the head-up detector (LED anode)
3	GND	GND (common ground for the head-up and paper detectors)
4	PS	Output signal of the paper detector (collector output of a photo-transistor)
5	V _{PS}	Power supply of the paper detector (LED anode)
6	\overline{A}	Motor drive signal
7	B	Motor drive signal
8	A	Motor drive signal
9	\overline{B}	Motor drive signal

CHAPTER 5
DRIVE METHOD

5.1 THERMAL HEAD DRIVE TIMING

● **Input of print data**

Input of DAT and CLK transfer the print data to the shift register in serial input. "High" means printing and "Low" means no-printing in DAT. DAT data is read in at the rising edge of the CLK inputs. The transferred line of data is stored in the latch register by turning LATCH to "Low".

● **Input of the head activation pulse**

"High" of DST drives the heat elements of the thermal head. Then let DST go to "Low" after driving for the period calculated using the formula shown in **"3.6 CONTROLLING THE HEAD ACTIVATION (DST) PULSE WIDTH"**.

Figure 5-1 shows the example of timing chart of the thermal head driving.

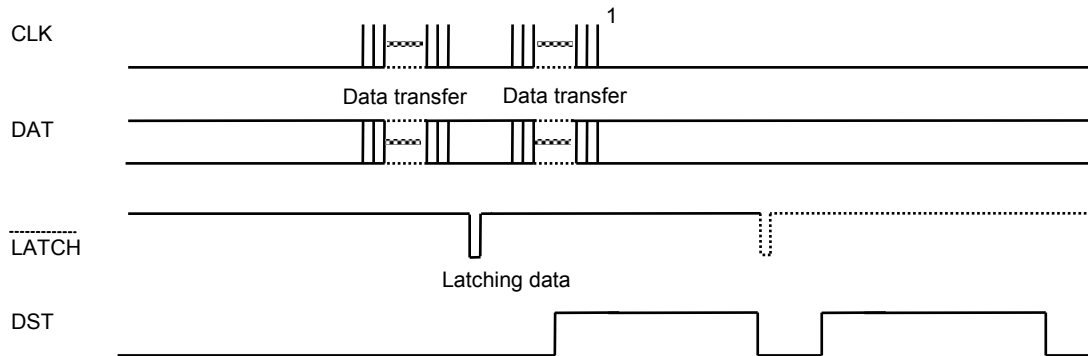

1: The print data for next dot line can be transferred immediately after storing the print data into the latch register.

Figure 5-1 Example of Timing Chart of the Thermal Head Driving

5.2 MOTOR DRIVE TIMING

The phase of motors and the thermal head need to be synchronized to print.

As example, the print method which divides one dot line to two groups; the blocks 1,3, and 5 and the blocks 2,4, and 6, and prints each group data for each step of the motor is described below.

Basic pulse width of the motor drive pulse, T_m , is a value (unit: msec) of the reciprocal number of the driving frequency calculated using equation (1) of "3.3 PAPER FEED CHARACTERISTICS".

- **Pause State**

Transfer the print data to the thermal head according to "5.1 THERMAL HEAD DRIVE TIMING".

- **Start up phase**

Excite the phase which is output just before the motor stops for the time of the start up in **Table 3-5**.

- **1st line, 1st step**

Drive the motor by one step (1st step). The step time should be the acceleration 1st step time or T_m , whichever is longer.

Set DST for the blocks 1, 3, and 5 to "High" in synchronization with the motor drive.

After setting DST to "High", set DST to "Low" when the driving time calculated in

"3.6 CONTROLLING THE HEAD ACTIVATION (DST) PULSE WIDTH" has passed.

Move to the 2nd step after the transfer of print data for the blocks 1, 3 and 5 and the 1st step time of the motor.

- **1st line, 2nd step**

Drive the motor by one step (2nd step). As to how much step time is output, compare T_m with the time that was taken in the previous step.

(1) In case $T_m <$ the time that was taken in the previous step,

the next closest acceleration step time to the previous step time or T_m , which is longer, is output.

(2) in case $T_m >$ the time that was taken in the previous step,

the closest acceleration step time to T_m and the acceleration step time that is larger than T_m , are output.

Set DST for blocks 2, 4, and 6 to "High" in synchronization with the motor drive. After setting DST to "High", set DST to "Low" after completion of the head activation time. Transfer the print data of the next dot line to the thermal head after completion of printing for blocks 2, 4, and 6.

Move to the 2nd dot line after completion of the 2nd step time of the motor and the transfer of print data for the next dot line.

- **2nd line, 1st step**

Drive the motor by one step (3rd step). As to how much step time is output, compare T_m with the time that was taken in the previous step.

- (1) in case $T_m <$ the time that was taken in the previous step,
the next closest acceleration step time to the previous step time or T_m , which is longer, is output.
- (2) in case $T_m >$ the time that was taken in the previous step,
the closest acceleration step time to T_m and the acceleration step time that is larger than T_m , are output.

Activate blocks 1, 3, and 5 in the same manner as the 1st line.

- **2nd line, 2nd step**

Drive the motor by one step (4th step). As to how much step time is output, compare T_m with the time that was taken in the previous step.

- (1) in case $T_m <$ the time that was taken in the previous step,
the next closest acceleration step time to the previous step time or T_m , which is longer, is output.
- (2) in case $T_m >$ the time that was taken in the previous step,
the closest acceleration step time to T_m and the acceleration step time that is larger than T_m , are output.

Activate blocks 2, 4, and 6 in the same manner as the 1st dot line, then transfer the next dot line data.

Print each line in the same manner continuously.

Figure 5-2 shows an example of the motor drive timing chart.

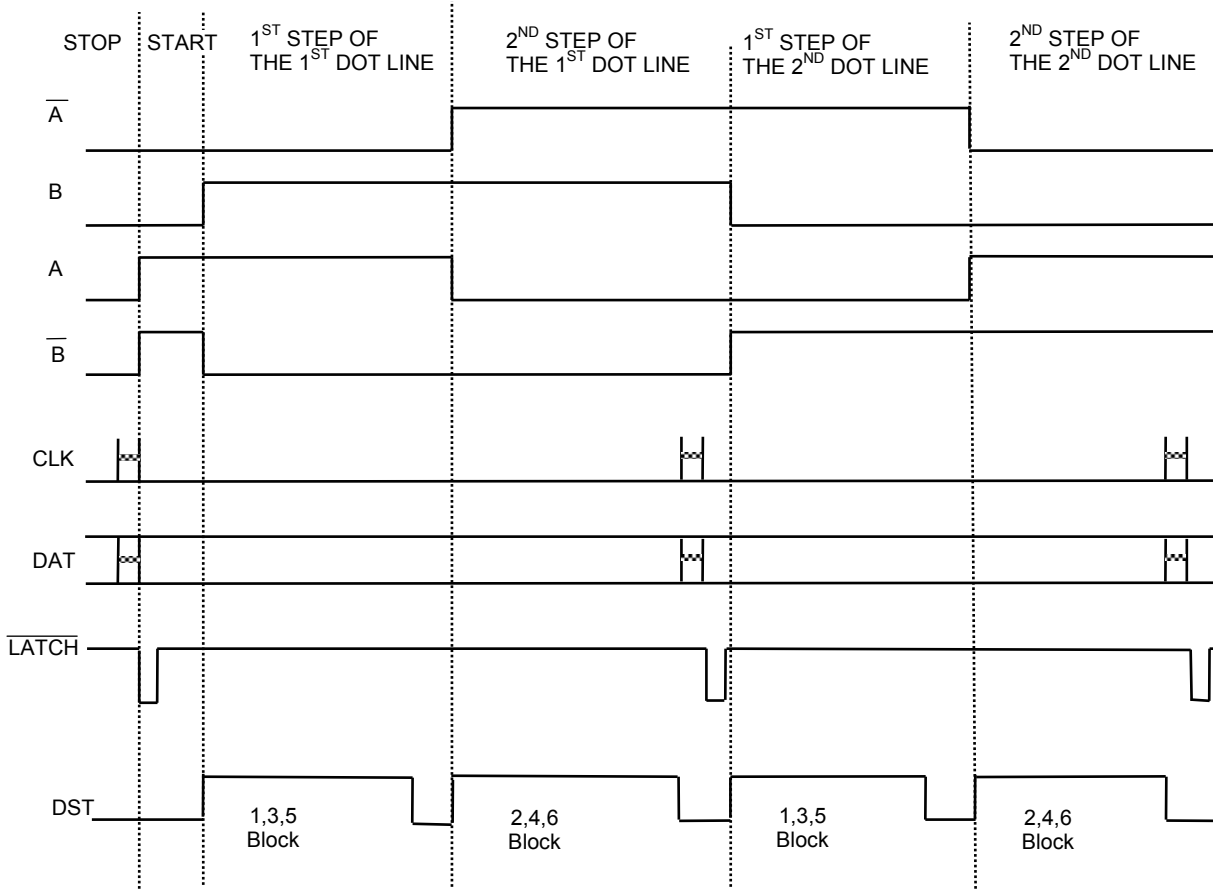

Figure 5-2 Example of Motor Drive Timing Chart

CHAPTER 6

HOUSING DESIGN GUIDE

6.1 SECURING THE PRINTER

The LTP1245 can be secured to the outer casing with screws.

6.1.1 Printer Mounting Method

Secure the printer with a mounting hole (ϕ 2.8) and 2 shaped indents.
See "**CHAPTER 7 APPEARANCE AND EXTERNAL DIMENSION**" for locations and dimensions.

Recommended Screws and Washers

Recommended mounting screws and washers are as follows:

- ① A combination of:
M2.5 or M2.6 pan head Phillips screw and
2.5 or 2.6 small round flat washer
- ② A combination of:
Pan head tapping screw 2.5 for resin and
2.5 small round flat washer

* Screws and washers with 6 mm or less outer diameter and 5 mm or less height in accordance with ① and ②.

6.1.2 Precautions for Securing the Printer

Secure the printer with the following attentions.
Securing the printer incorrectly may cause a deterioration of print quality, a paper skew, a paper jam and/or excessive noise.

- Design a printer mounting surface to secure the printer on the flat surface.
- Prevent excessive force, deformation or torsion on the printer when securing it.
- Secure the printer with 2 to 3 kgf screw torque in the up position of the thermal head.
- Design the case so that the thermal head terminal can be moved in 2 to 3 mm range due to the head up/down action.

6.2 LAYOUT OF PRINTER AND PAPER

- Design the paper outlet angle in 0 to 45°. (See **Figure 6-1**)

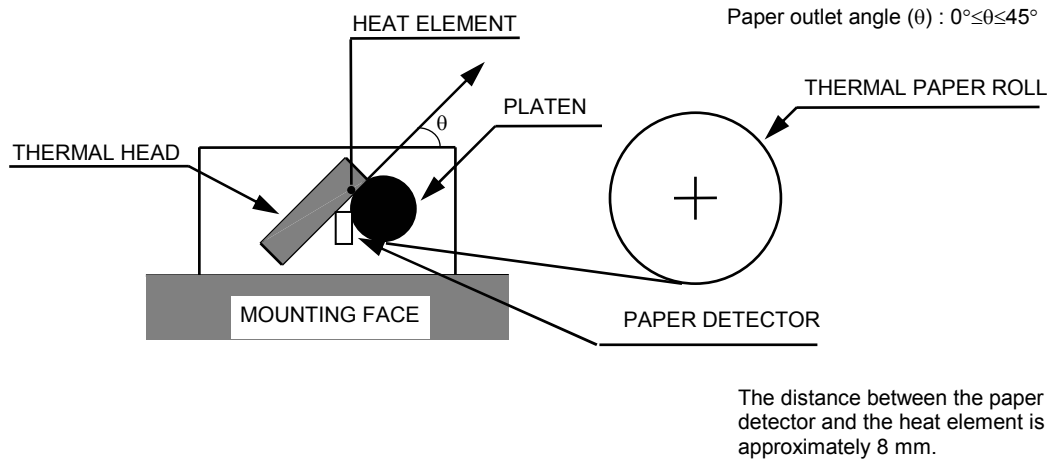

Figure 6-1 Paper Layout

6.3 WHERE TO MOUNT THE PAPER HOLDER

When determining the layout of paper holder, note the following:

- When you use a paper roll, set the holder so that the paper is in alignment with the paper intake with no horizontal offset, and that the center axis of the paper roll is parallel with the printer.
- Keep the paper feed force 50 gf or less.

6.4 WHERE TO MOUNT THE PAPER CUTTER

Install the paper cutter so that it does not interfere with the paper feed. The angles and positions for feeding paper are shown in "**CHAPTER 7 APPEARANCE AND DIMENSIONS**".

- If the distance between the edge of the thermal head and the edge of the fed paper is too small, the paper may be caught by the platen. Please take this into account when designing.
- Use a cutter with a sharp edge so that paper is cut with the paper hold force or less.

6.5 OUTER CASING STRUCTURE

Figure 6-2 shows a sample structure for the outer casing.

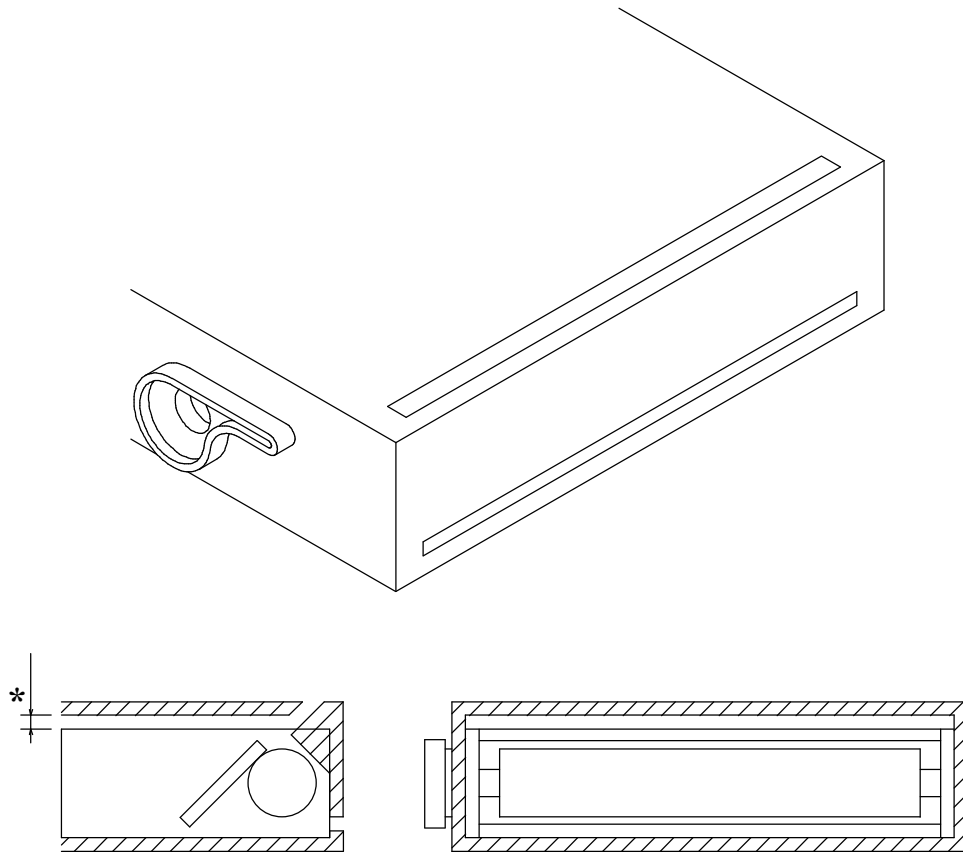

* Provide a gap of a few mm between the printer and the outer casing since the area over the thermal head becomes very hot.

Figure 6-2 Sample Outer Casing Structure

CHAPTER 7
APPEARANCE AND DIMENSIONS

Figure 7-1 shows the appearance and external dimensions of the LTP1245.

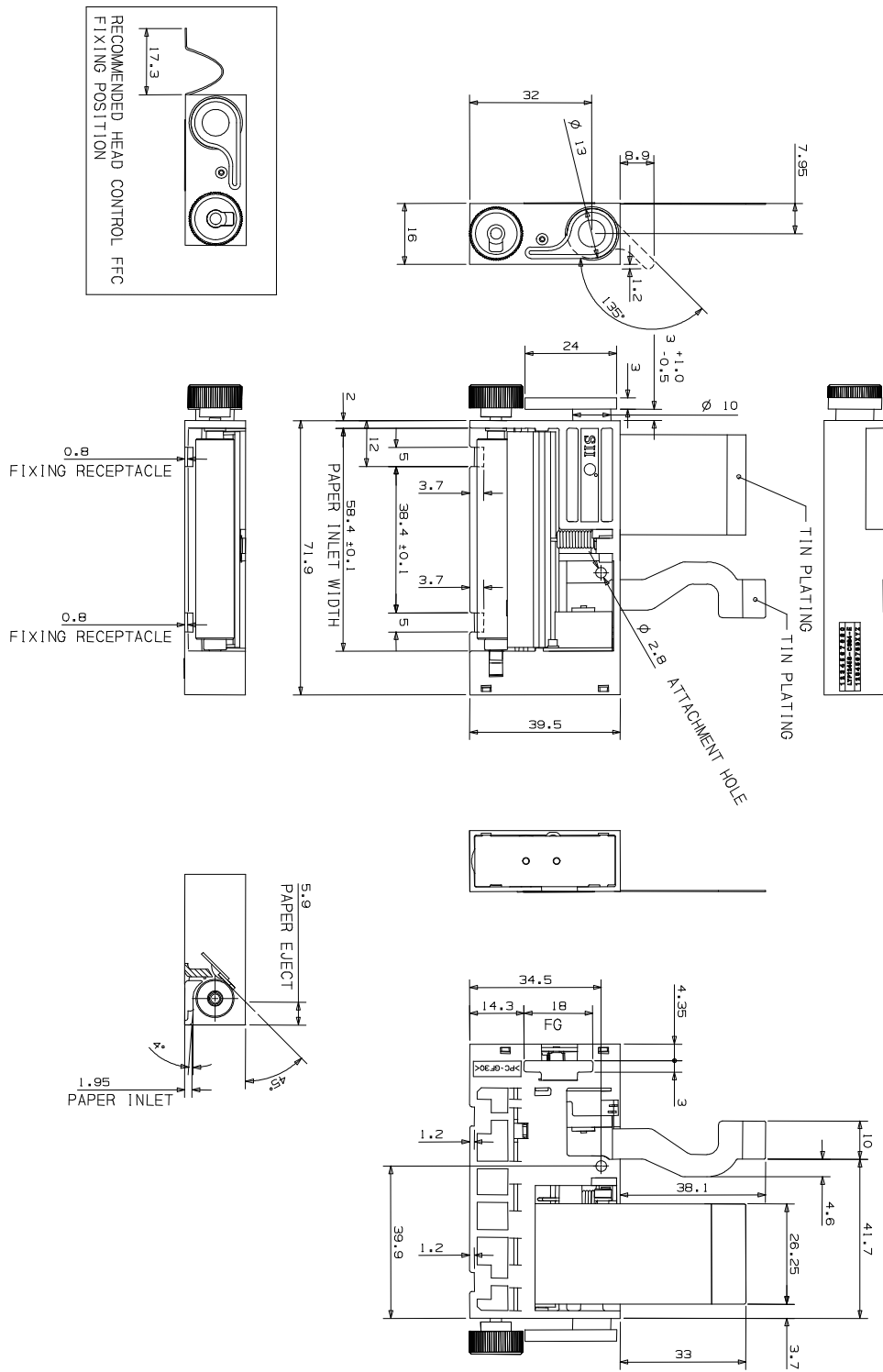

Unit : mm
Tolerance: ± 0.5 mm

Figure 7-2 LTP1245S-C384-E Appearance and Dimensions

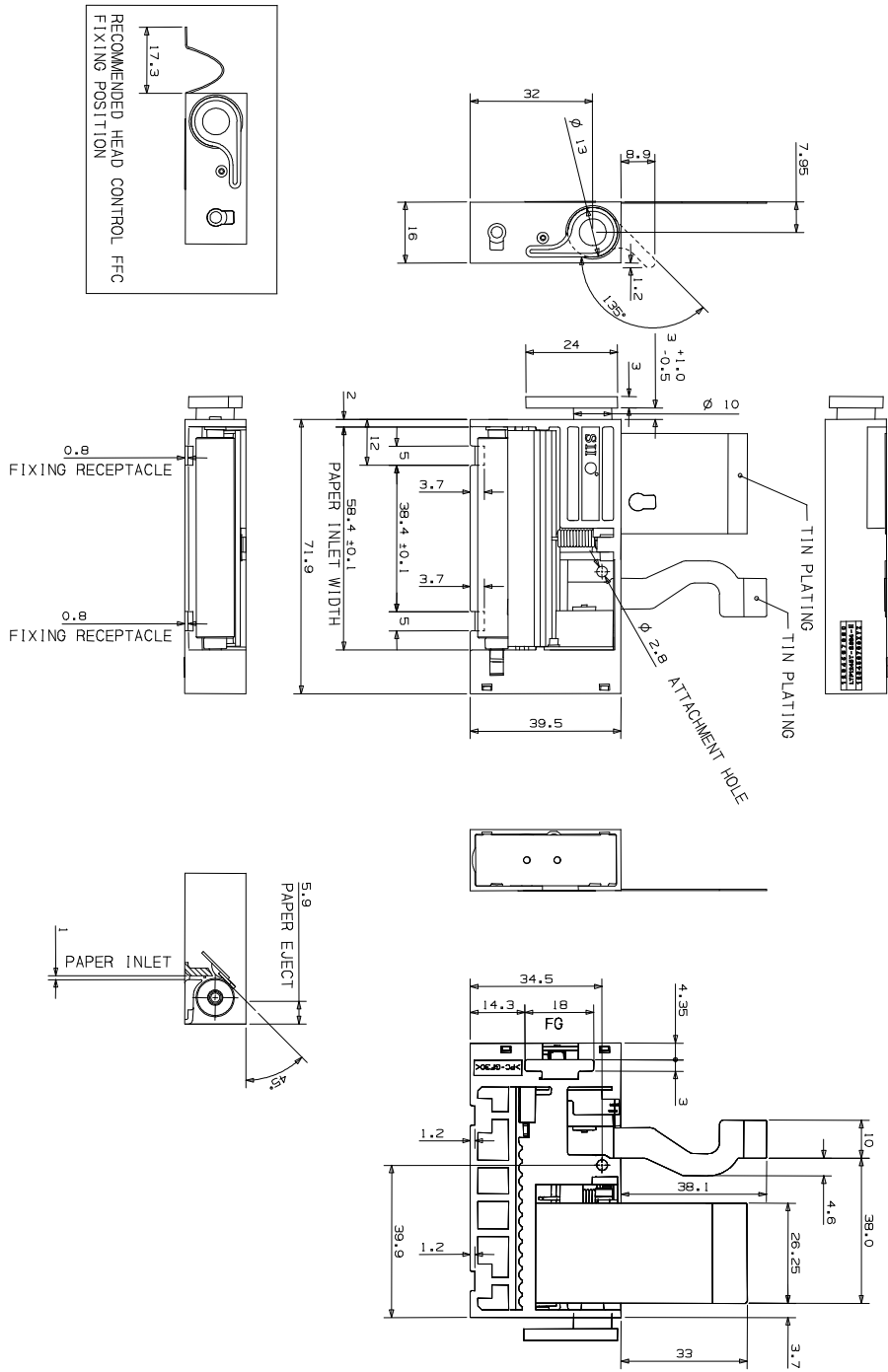

Unit : mm
Tolerance: ±0.5 mm

Figure 7-3 LTP1245T-S384-E Appearance and Dimensions

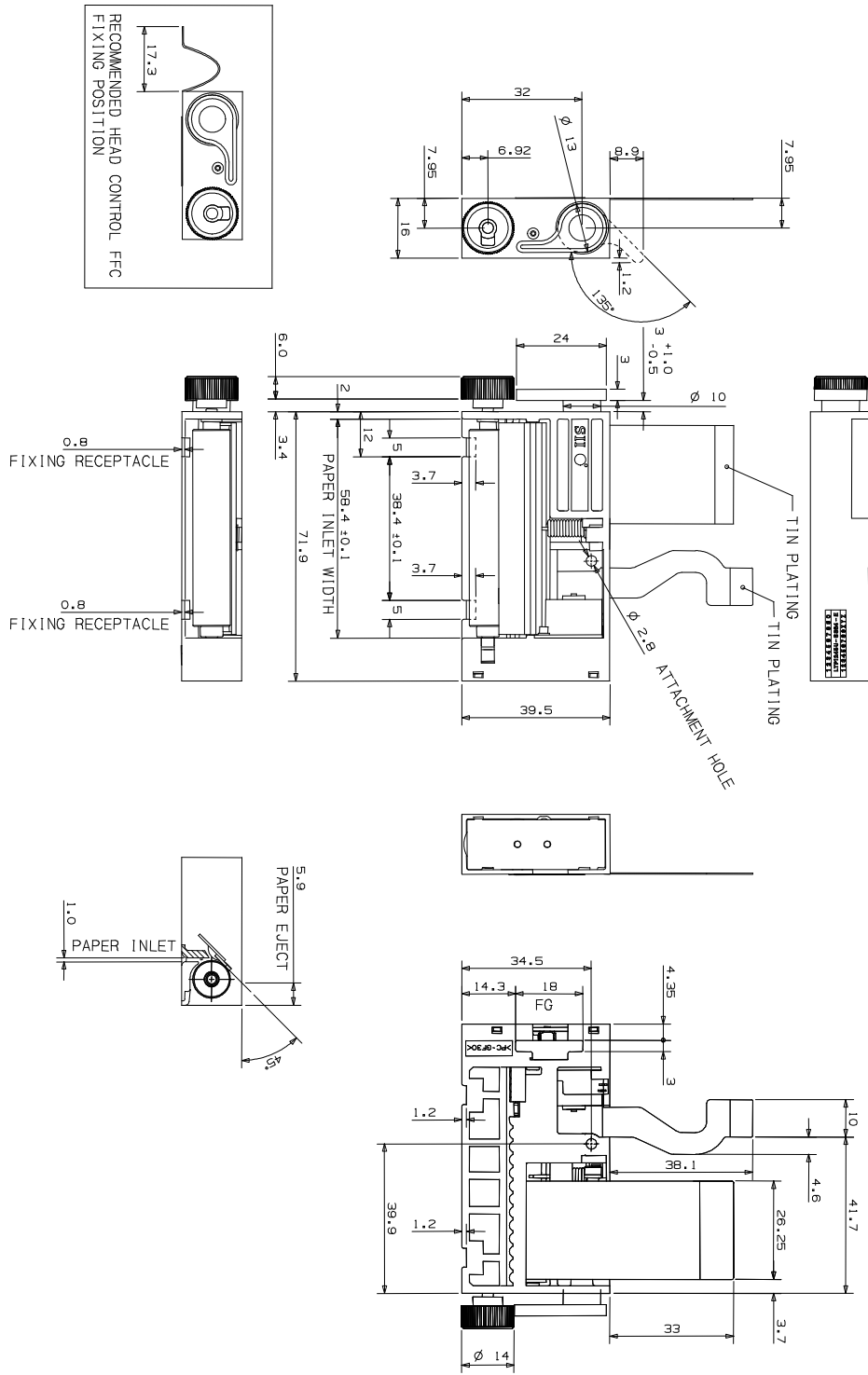

Figure 7-4 LTP1245U-S384-E Appearance and Dimensions

CHAPTER 8

LOADING/UNLOADING PAPER AND HEAD CLEANING

8.1 LOADING/UNLOADING PAPER PRECAUTIONS

① Loading paper

- Load paper with the thermal head in the up position.
(See **Figure 8-1 Head Cleaning Procedure (b)** in **Section 8.2 “HEAD CLEANING PROCEDURES AND PRECAUTIONS”**).
- Cut the edge of the paper so that the center of the paper will be inserted first

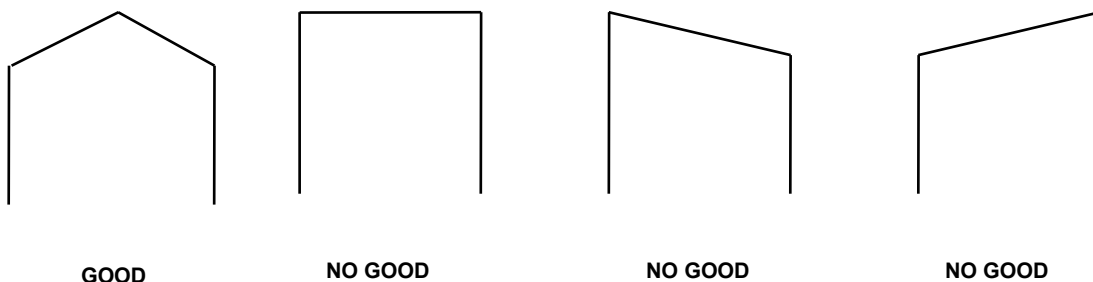

- Insert the paper straight into the paper inlet.
- When the edge of the paper comes up from between the thermal head and the platen, pull the edge of the paper, check whether the paper is aligned correctly, and place the thermal head into the down position.

② Unloading paper

- Unload paper with the thermal head in the up position.
(See **Figure 8-1 Head Cleaning Procedure (b)** in **Section 8.2 “HEAD CLEANING PROCEDURES AND PRECAUTIONS”**).
- Pull the paper straight up by hand in the direction in which the paper is normally fed.
- If the paper is bonded on the core of the paper roll, separate the paper from the core and then pull the paper out.

③ **Auto-loading paper**

- Cut the edge of the paper so it is vertical to the direction of the paper feed.

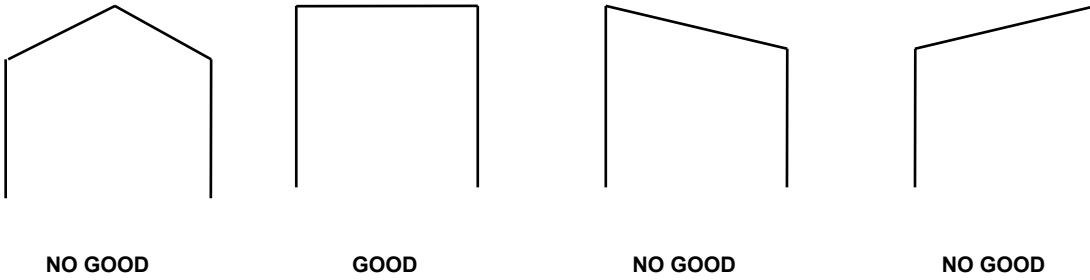

- Load paper with thermal head in the down position.
- If the paper skews, place the thermal head in the up position and reset the paper.
- If the thermal head has been in the down position for a long time, it will be impossible to insert because the head is in contact with the platen. In this case, place the head in the up position once and insert the paper again.

8.2 HEAD CLEANING PROCEDURE AND PRECAUTIONS

PROCEDURE :

- ① Lift the head up lever (a) so it stands upright (b).
- ② Clean the heat elements using alcohol and a cotton swab.
- ③ After cleaning, set the head up lever to its original position by reversing the steps.

PRECAUTIONS :

- ① Do not clean the thermal head immediately after printing because thermal head will still be hot.
- ② Cleaning fluid: ethyl alcohol, isopropyl alcohol.
- ③ Do not use sandpaper, cutter, etc. when cleaning. They will damage the heat elements.
- ④ Do not start printing operation until alcohol dries.

(a)



(b)

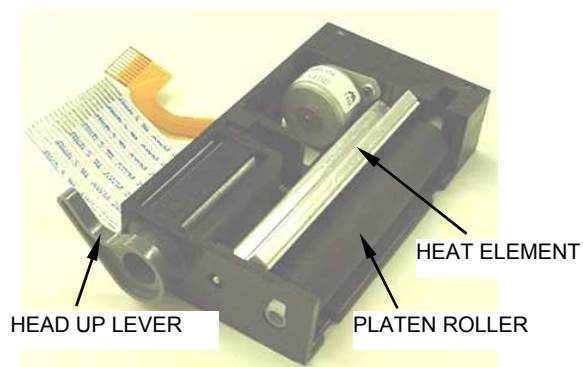

Figure 8-1 Head Cleaning Procedure

CHAPTER 9

PERIPHERAL EQUIPMENT

9.1 AUTOCUTTER UNIT

The LTP1245 can be equipped with the ACU6205 autocutter unit.

The ACU6205 autocutter unit uses the circular cut method.

The circular cut method enables the ACU6205 autocutter unit to be compact and lightweight.

For the specifications and the mechanism of how the ACU6205 operates, see the **ACU6205 AUTOCUTTER UNIT TECHNICAL REFERENCE**.

9.1.1 Installation

(1) When Using a Special Mount

- 1) Secure the printer on the special mount (OP-L1200-E) with the special screws.
- 2) The recommended tightening torque is 3 kgf cm (① in **Figure 9-1**).
- 3) Use four screws to secure the mount on the cabinet. Recommended screws: M2.6 (② in **Figure 9-1**).
- 4) Connect the FPC and FFC of the printer to the main unit.
- 5) Install the ACU6205 autocutter unit from the grounding plate side (③,④ in **Figure 9-1**).
- 6) Connect the cutter leads.

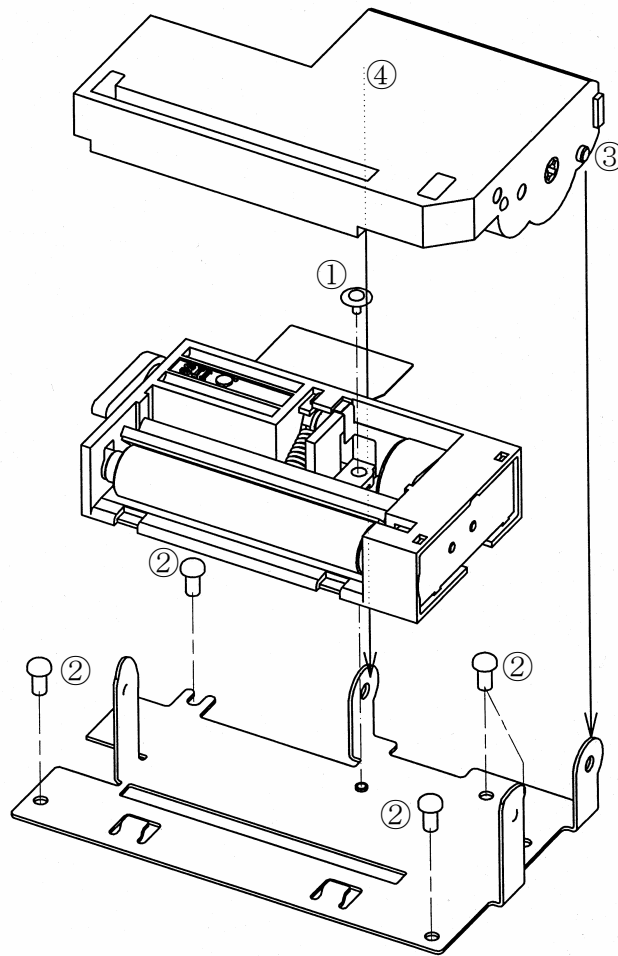

Figure 9-1 Installation

(2) When Designing a Mount

Design a mount so that the fulcrum for rotation is located as shown in **Figure 9-2**.

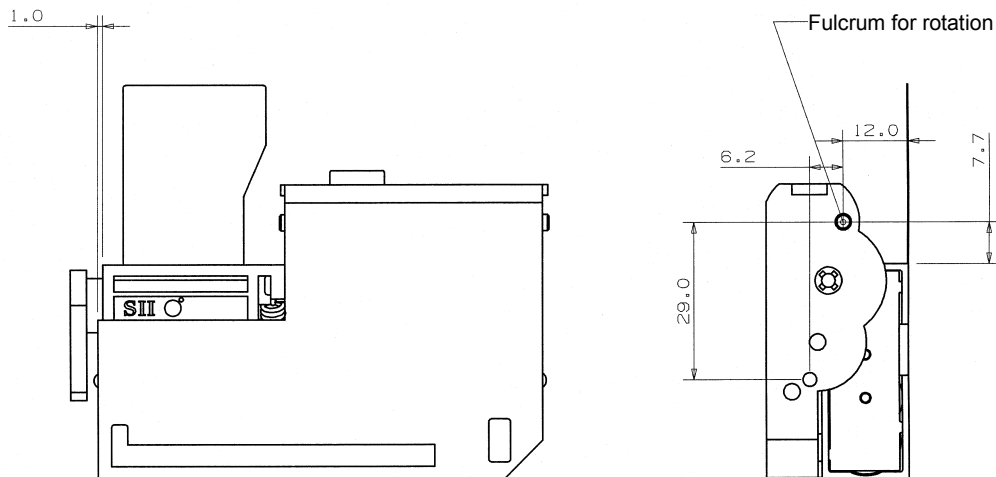

Figure 9-2 Designing a Mount

9.1.2 Opening and Closing the Autocutter Unit

Open the autocutter unit to insert sheets of paper manually or to clear paper jams. To open the autocutter unit, lift the part shown in **Figure 9-3**. Care should be taken to avoid causing damage to the platen. Before closing the autocutter unit, verify that the print head is down. Close the autocutter unit until it clicks.

Note 1: Do not raise the head when the autocutter unit is closed. Set the head up lever to the position shown in **Figure 9-4** to clear paper jams.

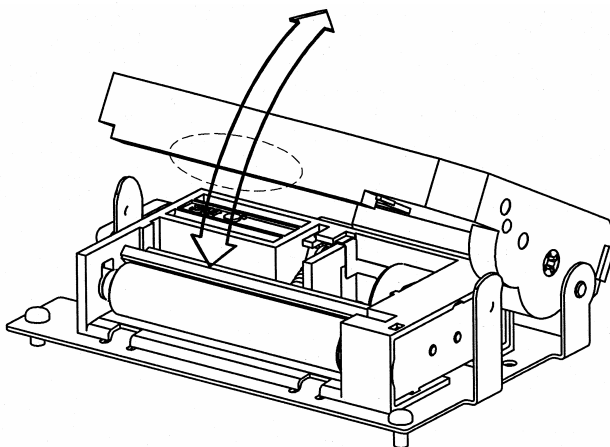

Figure 9-3 Opening and Closing of Autocutter Unit

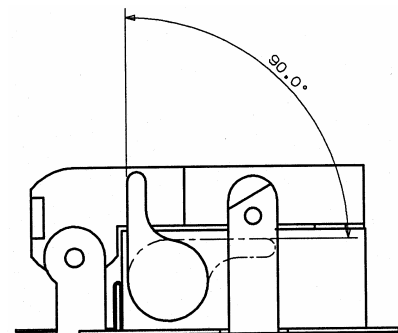

Figure 9-4 Head up Lever Position

9.1.3 Inserting Recording Paper

(1) Automatic paper insertion

Paper can be inserted automatically with the autocutter unit closed.

See ③ in **Section 8.1, LTP1245 LINE THERMAL PRINTER MECHANISM TECHNICAL REFERENCE**.

(2) Manual paper insertion

Open the autocutter unit and insert paper.

See ① in **Section 8.1, LTP1245 LINE THERMAL PRINTER MECHANISM TECHNICAL REFERENCE**.

After the printer setup, insert the paper into the paper feed slit in the autocutter, then close the autocutter unit.

(3) Recording paper removal

With the autocutter unit closed, turn the head up lever to the position shown in **Figure 9-4**, release the head and pull the paper out straight.

For information on how to clear paper jams, see **Section 9.1.4**.

9.1.4 Clearing Paper Jams

If a paper jam occurs, clear it as follows:

- 1) Turn off the printer and the autocutter.
- 2) Open the autocutter unit and remove the jammed paper.

For information on paper jams in the autocutter, see **CHAPTER 5, "CANCELING MOTOR (MOVABLE EDGE) LOCK IN THE "ACU6205 AUTOCUTTER UNIT TECHNICAL REFERENCE"**.

9.1.5 Hints for Use

- (1) Do not back feed paper after cutting paper using the autocutter unit because it will cause a paper jam.
- (2) To prevent paper from jamming, feed paper or print feed more than 3 mm after cutting paper.
- (3) To make the most efficient use of paper, as shown in **Figure 9-5**, print area A for the next print portion after printing area B, and then cut the paper.
- (4) If a partial cut is performed, the backlash absorption steps (40-step reverse rotation and 40-step normal rotation) should be included when printing starts after cutting paper (after pulling paper).

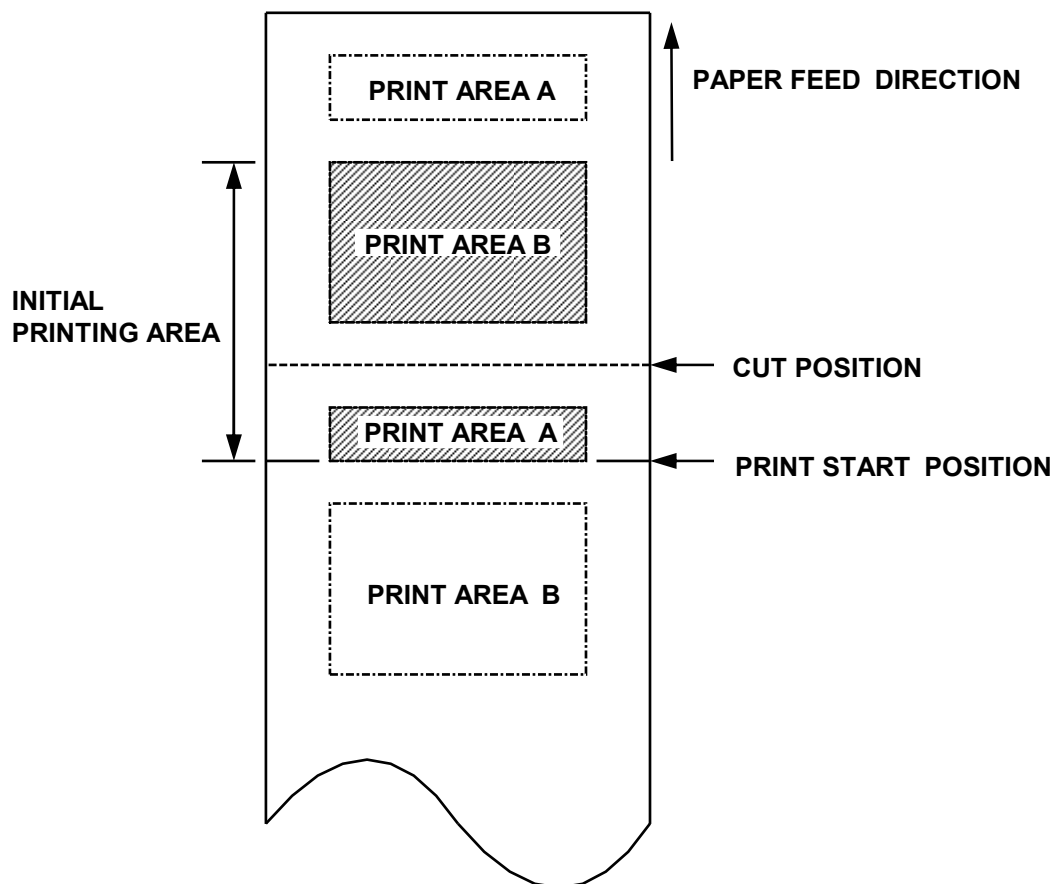

* Do not print on the cut position.

Figure 9-5 Best Cutting Position for Efficient Paper Use

9.2 LTP1245 MOUNT (OP-L1245A-E)

The LTP1245 can be secured on the cabinet using the LTP1245 mount (OP-L1245A-E) and four screws.

9.2.1 Installation

Align the two notches of the printer with the tabs on the LTP1245 mount (OP-L1245A-E) and secure the printer by installing a special screw (No.0 cross-recessed machine screw; tightening torque: 3 kgf • cm) in the printer installation hole. (2.8 mm diameter) (**Figure 9-7**).

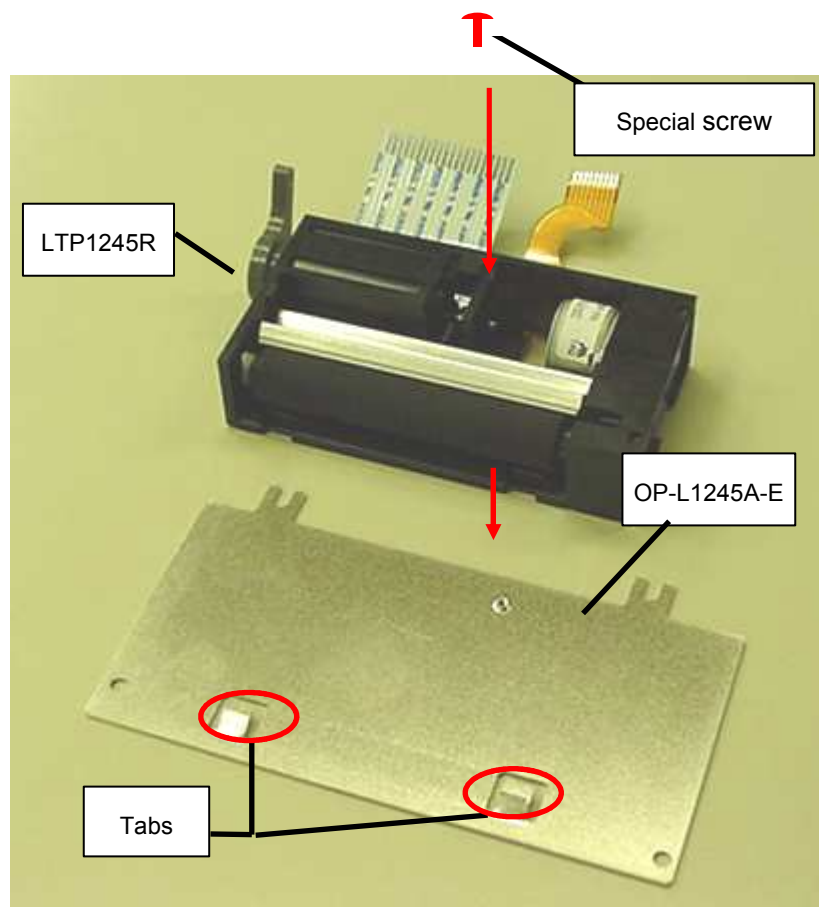
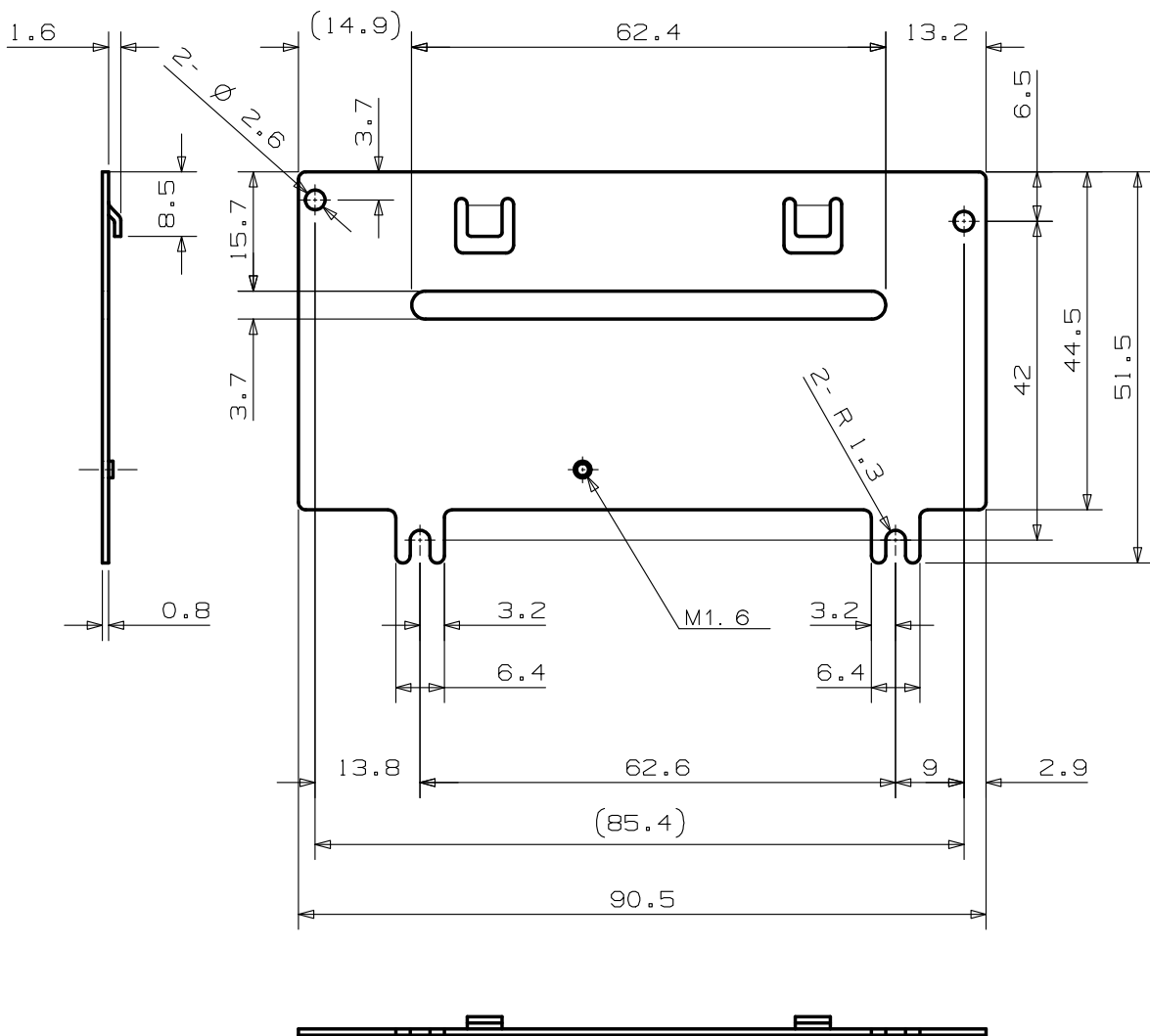

Figure 9-7 LTP1245 Mount Installation

9.2.2 OP-L1245A-E External View



Unit:mm

Figure 9-8 LTP1245 Mount External View (OP-L1245A-E)